

**SAN FRANCISCO BAY AREA RAPID TRANSIT DISTRICT**

---

**MEMORANDUM**

TO: BART Police Department, Chief of Police                      DATE: May 21, 2014

FROM: Independent Police Auditor

SUBJECT: **Policy Recommendation – BPD Policy 309**

Chapter 1-04(G) of the Citizen Oversight Model (Model) states that the Office of the Independent Police Auditor (OIPA) shall develop recommendations concerning General Orders and Directives, procedures, practices, and training of the BART Police Department (BPD), with the goal of improving professionalism, safety, effectiveness, and accountability. In accordance with this section of the Model, OIPA has developed a recommendation with regard to *BPD Policy 309 – Electronic Control Device - TASER*.

Many of the changes we are suggesting primarily involve a reorganization of the current policy in an attempt to maximize clarity and internal consistency. For instance, *Section 309.1 – Purpose and Scope* in the current policy presents a definition of what a Conducted Electrical Weapon (CEW) is, but not a clear purpose for the BPD TASER policy that follows. OIPA suggests moving the definition of CEW into *Section 309.1.1 – Definitions*. As another example, *Section 309.2(j)* in the current policy addresses an equipment question that is related to Department issued Oleoresin Capsicum, which has its own section devoted to it in a separate BPD policy. As this language appears to be superfluous with regard to *Policy 309*, we suggest removing it.

In addition to these types of recommendations, OIPA has also included a couple more substantive ones. One example concerns *Section 309.1 – Purpose and Scope*, which was previously mentioned. OIPA feels that it is indeed a good idea to set out a clear purpose and scope for this policy, so we crafted one to be used in that section. The primary substantive policy suggestion, however, is being made with regard to *Section 309.4 – Use of the TASER*. This section focuses on when an officer is/is not authorized to activate a TASER.

OIPA felt that this crucial section had some language that could potentially be confusing to both officers and members of the public. For example, one part of this section in the current policy indicates that a suspect must pose an “immediate threat” to an officer or a member of the public before the TASER may be activated. However, another part of the same section indicates that the TASER may be activated to subdue a subject who is merely “potentially... physically resisting” an officer (and not necessarily actually physically resisting), which seems to be a contrast with a subject who poses an immediate threat.

Although this portion of the policy does appropriately address the many considerations that factor into the appropriateness of a TASER activation by an officer, OIPA feels that it can be made clearer and, therefore, stronger. OIPA recommends starting this section by clearly stating the legal standard for what constitutes an acceptable use of force by a police officer. Then, subject to that standard, OIPA listed what it believes are illustrative examples of situations in which the activation of a TASER would/would not generally be appropriate. Our recommendations for this section were heavily influenced by the content and structure of the Model Policy on Electronic Control Weapons published by the International Association of Chiefs of Police.

In hopes of not introducing any new confusion or lack of clarity to *BPD Policy 309*, OIPA left intact as much of the original policy's language and formatting as possible in sections that were not directly affected by our recommendations. Additionally, OIPA presented a draft of its recommendations to the BART Citizen Review Board (CRB) at its meeting on May 12, 2014 for their review and comment. Taking those comments into account, OIPA has now finalized its recommendation.

Following is an unmarked copy of Policy 309, as issued; an annotated copy of Policy 309 that incorporates the suggestions being made by OIPA and includes commentary on the most notable ones; and a version of Policy 309 that is marked to show all of the edits being recommended.



---

Mark P. Smith  
BART Independent Police Auditor

## Electronic Control Device - TASER

### 309.1 PURPOSE AND SCOPE

The Conducted Electrical Weapon (CEW) is a less lethal device which is intended to temporarily incapacitate or stun a violent or potentially violent individual without causing serious injury. It is anticipated that the appropriate use of such a device will result in fewer serious injuries to officers and suspects.

#### 309.1.1 DEFINITIONS

**Verbal Warning Reference** - Any verbal notification to a subject(s) that an officer will activate a CEW.

**Deployment** - Removal of the CEW from the holster, regardless of where the CEW is held or pointed.

**Activation** - Depressing the trigger of the CEW causing an arc or firing the probes.

(For report writing purposes and supervisory response, exceptions to activation reporting are Department training and spark and maintenance tests).

### 309.2 POLICY

The only CEW authorized and issued by this Department is the TASER® X26. All sworn personnel shall receive Department-approved training and may be issued a TASER for use during their current assignment.

- (a) A TASER shall be assigned and carried (i.e., worn on the person, as described at the end of this Section) as a part of a uniformed officer's and sergeant's equipment, in a holster that is designed to fit the TASER® X26. Employees must request and have the approval of the Chief, or his designee, to *not* carry the TASER as part of their uniform equipment. Non-uniformed officers may secure the TASER in the driver's compartment of their Department vehicle.
- (b) All TASERS shall be clearly and distinctly marked with factory yellow X26 markings on the sides to differentiate them from the duty weapon and any other device.
- (c) Officers should carry a total of two or more TASER cartridges on their person when carrying the TASER. Only Department issued cartridges are authorized.
- (d) Officers shall be responsible for ensuring that their assigned TASER is properly maintained and in good working order at all times. Whenever an assigned TASER is damaged or inoperable, the officer shall immediately notify his/her supervisor and document the specific damage or inoperability issue in a memo sent via the chain of command to the Support Services Deputy Chief. The notified supervisor shall make an effort to have a reserve TASER assigned to the officer during that shift. Reserve TASERS shall be located in the Watch Commander's cabinet at LMA. The supervisor shall document the damaged TASER's serial number and the assigned officer's name and badge number in an email to the Support Services Lieutenant to facilitate the equipment repair.
- (e) TASERS shall not be altered from the original factory specifications and markings.
- (f) Officers should not hold both a firearm and the TASER at the same time unless lethal force is justified.

# Bay Area Rapid Transit Police Department

## Policy Manual

### *Electronic Control Device - TASER*

---

- (g) Officers who locate a broken cartridge or have an unintentional discharge shall forward the cartridge to a Department TASER armorer. It should be loosely packaged and sealed in a brown evidence bag.
- (h) TASERS with a battery life of 20% or less shall be removed from service. These TASERS should be forwarded to the Support Services Lieutenant for battery replacement.
- (i) The Support Services Lieutenant will ensure that TASER armorers conduct annual TASER memory downloads for all TASERS.
- (j) Due to the flammable contents in some chemical agent containers, officers shall only carry Department issued Oleoresin Capsicum (OC), which is water based and will not ignite.

There are two authorized ways for officers to carry the TASER:

- In a holster, opposite side from the duty weapon with no portion of the TASER crossing the mid-line of the officer's belt when it is holstered. When carried in this manner, the officer shall use a support-hand draw only.
- In a drop leg holster, worn on the support hand side only (opposite the duty weapon). When carried in this manner, the officer shall use a support-hand draw only.

### **309.3 VERBAL AND VISUAL WARNINGS**

Unless it would otherwise endanger officer safety or is impractical due to circumstances, a verbal announcement of the intended use of the TASER shall precede its application in order to:

- (a) Provide the individual with a reasonable opportunity to voluntarily comply
- (b) Provide other officers and individuals with warning that a TASER may be activated

If after a verbal warning an individual continues to express an unwillingness to voluntarily comply with an officer's lawful orders, and it appears both reasonable and practical under the circumstances, the officer may, but is not required to, display the electrical arc (provided there is not a cartridge loaded into the TASER) or laser in a further attempt to gain compliance prior to the application of the TASER. The aiming laser should never be intentionally directed into the eyes of another as it may permanently impair his/her vision.

The fact that a verbal and/or other warning was given, or reasons a warning was not given, shall be documented in any related reports.

### **309.4 USE OF THE TASER**

It is essential that officers exercise sound discretion and consider the totality of the circumstances surrounding any incident where the TASER may be activated. Objective facts must indicate the suspect poses an immediate threat to the officer or a member of the public.

As with any law enforcement equipment, the TASER has limitations and restrictions requiring consideration before its use. The TASER should only be used when its operator can safely approach the subject within the operational range of the TASER. Although the TASER rarely fails and is generally effective in subduing most individuals, officers should be aware of this potential and be prepared with other options in the unlikely event of such a failure.

# Bay Area Rapid Transit Police Department

## Policy Manual

### *Electronic Control Device - TASER*

---

Every application of the TASER becomes a separate use of force and must be justified by the officer. In instances where a warning is provided prior to the use of the TASER, the subject must be given reasonable time to comply.

If, after a single application of the TASER, an officer is still unable to gain compliance from an individual and circumstances allow, the officer should consider:

- Whether or not the probes are making proper contact
- If use of the TASER is limiting the ability of the individual to comply
- If other options or tactics may be more appropriate

This, however, shall not preclude an officer from multiple, reasonable applications of the TASER on an individual. When probes are in contact with the individual or when drive stun mode is in contact with the individual, no more than three activations should be administered on the same individual. The TASER should not be intentionally activated at the subject's head, neck, chest, or groin.

Authorized personnel may use the TASER when circumstances known to the individual officer at the time indicate that the application of the TASER is reasonable to subdue or control:

- (a) A violent or physically resisting subject.
- (b) A potentially violent or physically resisting subject, if:
  1. The subject has verbally or physically demonstrated an intention to resist; and
  2. The officer is able to justify that the use is based upon an objectively reasonable belief that a suspect poses an immediate threat to the officer or others; and
  3. The officer has given the subject a verbal warning of the intended use of the TASER followed by a reasonable opportunity to voluntarily comply; and
  4. Other available options reasonably appear ineffective or would present a greater danger to the officer or subject.
- (c) A vicious animal that appears to present a danger to the officer or the public.

Although not absolutely prohibited officers should avoid, absent extenuating circumstances, applying the TASER to any of the following individuals:

- (a) Pregnant females
- (b) Elderly individuals, obvious juveniles, or the visibly frail
- (c) Individuals who have been recently sprayed with alcohol-based pepper spray or potentially flammable chemical agents, or who are otherwise in close proximity to any combustible material
- (d) Individuals whose position or activity may result in collateral injury (e.g., falls from height, operating vehicles)
- (e) Handcuffed persons, unless they pose an immediate threat of great bodily injury to themselves or others
- (f) Fleeing subjects (fleeing should not be the sole justification for activating a TASER against a subject; personnel should consider the severity of the offense, the subject's threat level to others, and the risk of serious injury to the subject before deciding to use a TASER on a fleeing subject)

# Bay Area Rapid Transit Police Department

## Policy Manual

### *Electronic Control Device - TASER*

---

- (g) Subjects who are simply non-compliant or who are in control of a vehicle in motion (including automobiles, motorcycles and bicycles).
- (h) Individuals suspected of being under the influence of drugs/alcohol or exhibiting symptoms of excited delirium (e.g., nudity, profuse sweating, irrational behavior, extraordinary strength beyond physical characteristics or imperviousness to pain). These subjects may be more susceptible to collateral problems and should be closely monitored (e.g., breathing pattern) following the application of the TASER until they can be examined by paramedics or other medical personnel.

Personnel should evaluate whether the use of the TASER is reasonable, based upon all circumstances (including those listed above); if the TASER is used, the officer will be required to justify why the level of resistance or threat necessitated its use (e.g., potential for violence, nature of crime, proximity of weapons, etc.). In some cases, other control techniques may be more appropriate as determined by the subject's degree of resistance and/or threat level to others.

Because the application of the TASER in the drive stun mode (i.e., direct contact without darts) relies primarily on pain compliance and requires close proximity to the subject, the controlling effects may be limited. Additional caution should be exercised.

When the probes are in contact with a person, no more than one officer should intentionally activate a TASER against that person.

The TASER shall not be used:

- To torture, psychologically torment, or inflict undue pain on any individual
- As a prod or escort device
- To rouse unconscious, impaired, or intoxicated individuals

#### **309.4.1 FACTORS TO DETERMINE REASONABLENESS OF FORCE**

The application of the TASER is likely to cause intense, momentary pain. As such, officers should carefully consider and balance the totality of circumstances available prior to using the TASER including, but not limited to, the following factors:

- (a) The conduct of the individual being confronted (as reasonably perceived by the officer at the time)
- (b) Officer/subject factors (i.e., age, size, relative strength, skill level, injury/exhaustion, number of officers vs. subjects)
- (c) Influence of drugs/alcohol (mental capacity)
- (d) Proximity of weapons
- (e) The degree to which the subject has been effectively restrained and his/her ability to resist, despite being restrained
- (f) Time and circumstances permitting, the availability of other options (what resources are reasonably available to the officer under the circumstances)
- (g) Seriousness of the suspected offense or the reason for contact with the individual
- (h) Training and experience of the officer
- (i) Potential for injury to citizens, officers, and suspects
- (j) Risk of escape
- (k) Other exigent circumstances

# Bay Area Rapid Transit Police Department

## Policy Manual

### *Electronic Control Device - TASER*

---

#### **309.4.2 REPORT OF USE**

It is essential that officers exercise sound discretion and carefully articulate the totality of the circumstances giving rise to every TASER application. Verbal warnings, deployments, and TASER activations shall be documented in the related crime report. The TASER tab in the MO data entry section of the report writing program shall be utilized to document the type of usage (verbal, deployment, or activation). The incident shall be thoroughly documented in the narrative of the police report.

When the TASER is activated the police report should include the following:

- (a) Details of the subject's level of aggression justifying activation
- (b) Number and approximate duration of cycle(s)
- (c) Point of impact of the probes and/or drive stun mode on a subject
- (d) Response and actions of the subject after activation
- (e) Number of officers on scene
- (f) Names of individuals who provided medical care on scene and the names of medical personnel who removed the probes
- (g) Serial numbers of the TASER and cartridge
- (h) Photographic evidence, to include the subject prior to and after probe removal, the drive stun contact point, and any injuries incurred by the subject or officer as result of the incident
- (i) Name of the person receiving custody of the subject and advised of the TASER activation on the subject

Supplemental reports shall be completed by personnel who are present during an activation.

A TASER armorer shall download the on-board TASER memory and save it with the related crime report; the on-scene supervisor is responsible for assigning this task. TASERs will not be taken out of service after an activation unless directed by a command-level officer.

#### **309.4.3 SUPERVISORY RESPONSIBILITY**

A supervisor shall respond to the scene of any CEW activation including negligent or unintentional activations. The supervisor shall confirm (with the officer) that any probes that have pierced a subject's skin are removed by medical personnel and that the subject is medically cleared, as outlined in Section 309.5, prior to being booked into a detention facility. The supervisor will confirm that all evidence (including the CEW's memory record) has been collected, review and approve the related crime reports, and provide a replacement CEW cartridge(s) as necessary.

Upon reviewing the report, the supervisor must make a copy for review by the officer's chain of command and complete a Supervisor's Use of Force Report. The reviewing supervisor must review the use of the CEW and make a recommendation on whether the use of the CEW was justified or not. A copy of the approved police report and completed Use of Force Report will be forwarded to the Chief of Police via the chain of command. The incident will be reviewed in accordance with Policies 300 and 301.

**Justifiable:** When the circumstances, at the time of using the CEW, were consistent with the provisions of this Policy, the use of the device shall be classified as justifiable.

**Unjustifiable:** When the circumstances, at the time of using the CEW, were not consistent with the provisions of this Policy, the use of the device shall be classified as unjustifiable.

# Bay Area Rapid Transit Police Department

## Policy Manual

### *Electronic Control Device - TASER*

---

The Professional Standards and Training Division Deputy Chief will forward the police report and Use of Force Report to the Chief of Police for review. The Chief of Police will forward the report and signed Use of Force Report to the Internal Affairs Section who will log the report and send it and the Supervisor's Use of Force report to the Use of Force Review Committee Chairperson.

Negligent or unintentional activations of a CEW cartridge shall be reported immediately to a supervisor. The incident shall not be documented as a use of force. The incident shall be documented in a memo, via the chain of command to the Division Deputy Chief to which the employee reports. This memo will include the CEW and cartridge serial numbers and an explanation of the circumstances surrounding the activations. Officers responsible for accidental, unintentional or unjustifiable discharges shall be subject to progressive discipline. Negligent activations shall be included in the Departments Early Intervention system.

### **309.5 MEDICAL TREATMENT**

Only qualified medical personnel, including certified paramedics, should remove TASER darts from a person's body. Used TASER darts shall be considered a sharp biohazard, similar to a used hypodermic needle. Universal precautions should be taken accordingly.

All detained or arrested persons who have been struck by TASER darts or who have been subjected to the electric discharge of the device shall be transported, by medical personnel, for medical assessment at a local medical facility as soon as practicable.

Special consideration (including enhanced observation and a Code 3 medical response) should be provided to individuals who fall under any of the following categories:

- (a) The person is suspected of being under the influence of a controlled substance(s) and/or alcohol
- (b) The person may be pregnant
- (c) The person reasonably appears to be in need of medical attention
- (d) The TASER darts are lodged in a sensitive area (e.g., groin, female breast, near the eyes)
- (e) The person requests medical treatment

In addition, persons who exhibit extreme agitation, violent irrational behavior accompanied by profuse sweating, extraordinary strength beyond physical characteristics, imperviousness to pain, or who require a protracted physical encounter with multiple officers to bring them under control, may be at an increased risk of sudden death and should be examined by qualified medical personnel as soon as practicable (a Code 3 medical response). All individuals shall be medically cleared, prior to booking.

If any person subjected to an unintentional application refuses medical attention, such a refusal should, absent extenuating circumstances, be witnessed by medical personnel and shall be fully documented in related reports. If an audio recording is made of the contact or interview with the individual, any refusal should be included.

The transporting officer shall inform any person receiving custody or any person placed in a position of providing care that the individual has been subjected to the application of the TASER.



# Bay Area Rapid Transit Police Department

## Policy Manual

### *Electronic Control Device - TASER*

---

#### **309.6 TRAINING**

In addition to the initial Department approved training required to carry and use a TASER, annual training will be provided to all sworn personnel. A reassessment of an officer's knowledge and/or practical skills may be required at any time if deemed appropriate.

A certified TASER instructor should ensure that TASER training material and lesson plans include the following:

- (a) A review of this Policy
- (b) A review of the Use of Force Policy 300
- (c) Target area considerations, to include techniques or options to reduce the intentional application of probes near the head, neck, chest, and groin
- (d) De-escalation techniques
- (e) Scenario-based training

##### **309.6.1 TASER INSTRUCTOR TRAINING**

The below, listed training is from the Department's Training Plan and is either mandatory, essential, or desirable (the Training Plan is located within the G/drive, Training Unit folder):

- Mandatory TASER training - Basic instructor course
- Desirable TASER training - TASER armorer certification course, advanced instructor course

##### **309.6.2 REMEDIAL TRAINING**

Any employee who acts in a grossly unsafe manner or demonstrates dangerous and/or extremely poor decision-making skills in the deployment of and/or application of any use-of-force related task (in the field or in training) shall be required to attend mandatory remedial training prior to returning to full-duty status.

If, in the opinion of the supervisor/primary instructor at the site of the training, the employee's decision making and actions are so unsafe that if returned to full duty he/she may be a safety hazard to him or herself, fellow employees, and/or the public, the supervisor/primary instructor shall recommend additional mandatory remedial training for the employee. The primary instructor shall contact the on-duty Watch Commander as soon as practicable and make the recommendation for additional mandatory remedial training.

If the request for additional training is approved, the employee shall be removed from an on-duty patrol status and placed into a temporary administrative position until such time as that employee satisfactorily completes the mandatory remedial training.

Repeated failures to correct such deficiencies may result in implementation of the Progressive Discipline System, similar to Policy Section 461.5.1. Nothing in this Policy precludes the Department from requiring an employee to successfully complete remedial training to correct lesser safety violations and/or marginal tactical decision-making skills, without the employee first being removed from full-duty status.

#### **309.7 TASER® X26 NOMENCLATURE**

- 1 - Probes
- 2 - AFID Tags
- 3 - TASER Cartridge

# Bay Area Rapid Transit Police Department

## Policy Manual

### *Electronic Control Device - TASER*

---

- 4 - Mechanical Sight
- 5 - Serial Number Plate
- 6 - Illumination Selector Switch
- 7 - Safety Switch
- 8 - Central Information Display (CID)
- 9 - DPM Release Button
- 10 - Stainless Steel Shock Plate
- 11 - Digital Power Magazine (DPM)
- 12 - Trigger
- 13 - Low Intensity Lights (LIL)
- 14 - Built-in Laser (pointing to beam)

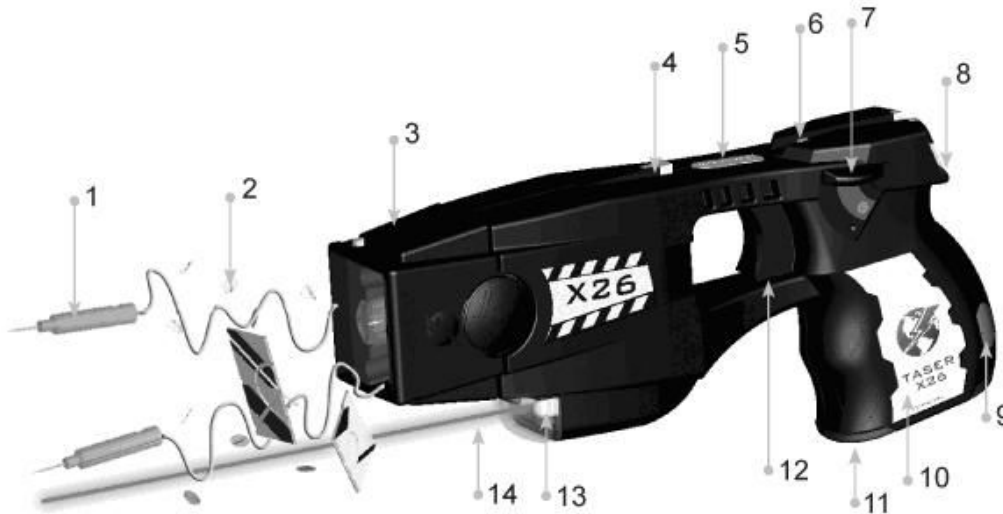

## Conducted Electrical Weapon (TASER)

### 309.1 PURPOSE AND SCOPE

The purpose of this policy is to provide direction on what constitutes the appropriate and authorized use of conducted electrical weapons.

### 309.2 DEFINITIONS

**Conducted Electrical Weapon (CEW)** - a device that uses electricity to temporarily incapacitate, stun, or apply pain to an individual in order to overcome resistance.

**Verbal Warning** - A verbal notification to a subject and/or nearby officers that an officer will activate a CEW.

**Deployment** - Removal of the CEW from the holster, regardless of where the CEW is held or pointed.

**Activation** - Depressing the trigger of the CEW causing an arc of electricity and/or the firing of the probes.

(For report writing purposes and supervisory response, exceptions to activation reporting are Department training and spark and maintenance tests).

### 309.3 EQUIPMENT

The only CEW authorized and issued by this Department is the TASER® X26. All sworn personnel shall receive Department-approved training and may be issued a TASER for use during their current assignment. No officer is authorized to deploy or activate a TASER prior to receiving Department-approved training.

- (a) A TASER shall be assigned and carried (i.e., worn on the person, as described at the end of this Section) as a part of each uniformed officer's and sergeant's equipment, in a holster that is designed to fit the TASER® X26. Employees must request and have the approval of the Chief, or his designee, to *not* carry the TASER as part of their uniform equipment. Non-uniformed officers may secure the TASER in the driver's compartment of their Department vehicle.
- (b) All TASERs shall be clearly and distinctly marked with factory yellow X26 markings on the sides to differentiate them from the duty weapon and any other device.
- (c) Officers should carry a total of two or more TASER cartridges on their person when carrying the TASER. Only Department issued cartridges are authorized.
- (d) Officers shall be responsible for ensuring that their assigned TASER is properly maintained and in good working order at all times. Whenever an assigned TASER is damaged or inoperable, the officer shall immediately notify his/her supervisor and document the specific damage or inoperability issue in a memo sent via the chain of command to the Support Services Deputy Chief. The notified supervisor shall make an effort to have a reserve TASER assigned to the officer during that shift. Reserve TASERs shall be located in the Watch Commander's cabinet at LMA. The supervisor shall document the damaged TASER's serial number and the assigned officer's name and badge number in an email to the Support Services Lieutenant to facilitate the equipment repair.

**Comment [OIPA1]:** This title reflects the definition used elsewhere in this policy, and it also reflects the term of art presently in use by TASER, Inc., which is the only Conducted Electrical Weapon authorized for use by the BART Police Department.

**Comment [OIPA2]:** This section has been modified to provide a clear purpose to the policy, as opposed to a definition of Conducted Electrical Weapon (which has instead been moved to the subsequent section).

**Comment [OIPA3]:** This section, which focuses on authorized equipment, malfunctioning equipment, and carrying of equipment, has been renamed and modified for internal consistency.

# Bay Area Rapid Transit Police Department

## Policy Manual

### *Conducted Electrical Weapon - TASER*

---

- (e) TASERS shall not be altered from the original factory specifications and markings.
- (f) Officers who locate a broken cartridge or have an unintentional discharge shall forward the cartridge to a Department TASER armorer. It should be loosely packaged and sealed in a brown evidence bag.
- (g) TASERS with a battery life of 20% or less shall be removed from service. These TASERS should be forwarded to the Support Services Lieutenant for battery replacement.
- (h) The Support Services Lieutenant will ensure that TASER armorers conduct annual TASER memory downloads for all TASERS.

There are two authorized ways for officers to carry the TASER:

- In a holster, opposite side from the duty weapon with no portion of the TASER crossing the mid-line of the officer's belt when it is holstered. When carried in this manner, the officer shall use a support-hand draw only.
- In a drop leg holster, worn on the support hand side only (opposite the duty weapon). When carried in this manner, the officer shall use a support-hand draw only.

#### 309.4 USE OF THE TASER

It is the policy of this Department that an officer shall use only that amount of force which is objectively reasonable in light of the facts and circumstances confronting the officer at the time of the event giving rise to the use of force. Activation of the TASER is, at all times, subject to this standard. Each individual activation of the TASER, even during the same incident, becomes a separate use of force and must be objectively reasonable. In some cases, other control techniques may be more appropriate as determined by the subject's degree of resistance and/or threat level to others.

Subject to the objective reasonableness standard, an officer generally may activate the TASER when grounds to arrest or detain are present, and the subject:

- Uses force or attempts to use force against the officer or another person
- Physically resists the arrest or detention or demonstrates an intention to physically resist (such as the assumption of a fighting stance)
- Refuses to comply with verbal orders without any physical resistance or demonstrated intention to physically resist, but is believed to be armed
- Flees in order to evade arrest or detention and presents an imminent or immediate threat to the officer or other individuals

Officers may also generally activate the TASER to subdue a vicious animal that presents a danger to the officer or other individuals.

Similarly subject to the objective reasonableness standard, an officer generally may not activate the TASER when the subject:

- Refuses to comply with verbal orders without any physical resistance or demonstrated intention to physically resist, and is not believed to be armed
- Flees in order to evade arrest or detention but does not present an imminent or immediate threat to the officer or other individuals

**Comment [OIPA4]:** This section contains the primary substantive recommendations for change to the policy. In an attempt to minimize confusion regarding the recommended changes to the policy, OIPA attempted to retain language from the original policy wherever possible (including when that language is moved from one part of the policy to another).

OIPA feels it is important to clearly identify the legal standard for what constitutes acceptable force by a police officer, and we did so in the first sentence of this section. References to this paramount legal standard are repeated throughout this section.

Within that legal standard, OIPA next presents some likely scenarios in which the use of a TASER would generally be appropriate; this is followed by examples of when the use of a TASER would generally be inappropriate. OIPA feels that these examples provide increased clarity for officers when compared with the original policy's categorization of a potentially violent or physically resisting subject, upon whom a TASER may be used only if each of 4 additional conditions regarding the subject have been met, according to the involved officer. On a separate note, the recommended language also brings the policy more in line with the Model Policy on Electronic Control Weapons adopted by the International Association of Chiefs of Police National Law Enforcement Policy Center.

# Bay Area Rapid Transit Police Department

## Policy Manual

### *Conducted Electrical Weapon - TASER*

---

Although not absolutely prohibited, officers should avoid, absent extenuating circumstances, applying the TASER to any of the following individuals:

- (a) Pregnant females
- (b) Elderly individuals, obvious juveniles, or the visibly frail
- (c) Individuals who have been recently sprayed with alcohol-based pepper spray or potentially flammable chemical agents, or who are otherwise in close proximity to any combustible material
- (d) Individuals whose position or activity may result in collateral injury (e.g., falls from height, operating vehicles)
- (e) Handcuffed persons, unless they pose an immediate threat of great bodily injury to themselves or others
- (f) Subjects who are in control of a vehicle in motion (including automobiles, motorcycles and bicycles).
- (g) Individuals suspected of being under the influence of drugs/alcohol or exhibiting symptoms of excited delirium (e.g., nudity, profuse sweating, irrational behavior, extraordinary strength beyond physical characteristics or imperviousness to pain). These subjects may be more susceptible to collateral problems and should be closely monitored (e.g., breathing pattern) following the application of the TASER until they can be examined by paramedics or other medical personnel.

Officers should not hold both a firearm and the TASER at the same time unless lethal force is justified. The TASER shall never be used:

- (a) To torture, psychologically torment, or inflict undue pain on any individual
- (b) As a prod or escort device
- (c) To rouse unconscious, impaired, or intoxicated individuals

In addition to the specific circumstances listed above, all evaluations of a use of force subject to the objective reasonableness standard may take into account a number of factors including, but not limited to:

- (a) The conduct of the individual being confronted (as reasonably perceived by the officer at the time)
  - (b) Officer/subject factors (i.e., age, size, relative strength, skill level, injury/exhaustion, number of officers vs. subjects)
  - (c) Influence of drugs/alcohol (mental capacity)
  - (d) Proximity of weapons
  - (e) The degree to which the subject has been effectively restrained and his/her ability to resist, despite being restrained
  - (f) Time and circumstances permitting, the availability of other options (what resources are reasonably available to the officer under the circumstances)
  - (g) Seriousness of the suspected offense or the reason for contact with the individual
  - (h) Training and experience of the officer
  - (i) Potential for injury to citizens, officers, and suspects
  - (j) Risk of escape
  - (k) Other exigent circumstances
-

# Bay Area Rapid Transit Police Department

## Policy Manual

### Conducted Electrical Weapon - TASER

---

#### 309.4.1 ADDITIONAL CONSIDERATIONS

As with any law enforcement equipment, the TASER has limitations and restrictions requiring consideration before its use. The TASER should only be used when its operator can safely approach the subject within the operational range of the TASER. Officers should be aware of the potential that a TASER will fail to subdue an individual, and they should be prepared with other options in the event of such a failure.

If, after a single application of the TASER, an officer is still unable to gain compliance from an individual and circumstances allow, the officer should consider:

- (a) Whether or not the probes are making proper contact
- (b) Whether use of the TASER is limiting the ability of the individual to comply
- (c) Whether other options or tactics may be more appropriate

This, however, shall not preclude an officer from multiple, reasonable applications of the TASER on an individual. When probes are in contact with the individual or when drive stun mode is in contact with the individual, no more than three activations should be administered on the same individual. The TASER should not be intentionally activated at the subject's head, neck, chest, or groin.

Because the application of the TASER in the drive stun mode (i.e., direct contact without darts) relies primarily on pain compliance and requires close proximity to the subject, the controlling effects may be limited. Additional caution should be exercised.

When the probes are in contact with a person, no more than one officer should intentionally activate a TASER against that person.

#### 309.5 VERBAL AND VISUAL WARNINGS

Unless it would otherwise endanger officer safety or is impractical due to circumstances, a verbal warning of the intended use of the TASER shall precede its application in order to:

- (a) Provide the individual with a reasonable opportunity to voluntarily comply
- (b) Provide other officers and individuals with warning that a TASER may be activated

In instances where a verbal warning is provided prior to the use of the TASER, the subject must be given reasonable time to comply.

If after a verbal warning an individual continues to express an unwillingness to voluntarily comply with an officer's lawful orders, and it appears both reasonable and practical under the circumstances, the officer may, but is not required to, display the electrical arc (provided there is not a cartridge loaded into the TASER) or built-in laser in a further attempt to gain compliance prior to the application of the TASER. The laser should never be intentionally directed into the eyes of another as it may permanently impair his/her vision.

The fact that a verbal and/or other warning was given, or reasons a warning was not given, shall be documented in any related reports.

**Comment [OIPA5]:** OIPA retained most of the language that follows here from the original policy. As the language deals primarily with important considerations once a TASER has already been activated, however, OIPA separated into its own subsection within the larger "Use of the Taser" section.

**Comment [OIPA6]:** OIPA moved this language from another portion of the original policy into the section called "Verbal and Visual Warnings" for the sake of consistency.

# Bay Area Rapid Transit Police Department

## Policy Manual

### Conducted Electrical Weapon - TASER

---

#### 309.6 REPORT OF TASER USE

It is essential that officers exercise sound discretion and carefully articulate the totality of the circumstances giving rise to every TASER application. Verbal warnings, deployments, and TASER activations shall be documented in the related crime report. The TASER tab in the MO data entry section of the report writing program shall be utilized to document the type of usage (verbal, deployment, or activation). The incident shall be thoroughly documented in the narrative of the police report.

**Comment [OIPA7]:** The remainder of the policy does not contain any substantive recommendations for change. All remaining changes from the original policy are cosmetic in nature, such as renumbering for the sake of consistency.

When the TASER is activated the police report should include the following:

- (a) Details of the subject's level of aggression justifying activation
- (b) Number and approximate duration of cycle(s)
- (c) Point of impact of the probes and/or drive stun mode on a subject
- (d) Response and actions of the subject after activation
- (e) Number of officers on scene
- (f) Names of individuals who provided medical care on scene and the names of medical personnel who removed the probes
- (g) Serial numbers of the TASER and cartridge
- (h) Photographic evidence, to include the subject prior to and after probe removal, the drive stun contact point, and any injuries incurred by the subject or officer as result of the incident
- (i) Name of the person receiving custody of the subject and advised of the TASER activation on the subject

Supplemental reports shall be completed by personnel who are present during a TASER activation.

A TASER armorer shall download the on-board TASER memory and save it with the related crime report; the on-scene supervisor is responsible for assigning this task. TASERs will not be taken out of service after an activation unless directed by a command-level officer.

#### 309.7 SUPERVISORY RESPONSIBILITY

A supervisor shall respond to the scene of any TASER activation including negligent or unintentional activations. The supervisor shall confirm (with the officer) that any probes that have pierced a subject's skin are removed by medical personnel and that the subject is medically cleared, as outlined in Section 309.8, prior to being booked into a detention facility. The supervisor will confirm that all evidence (including the TASER's memory record) has been collected, review and approve the related crime reports, and provide a replacement TASER cartridge(s) as necessary.

Upon reviewing the report, the supervisor must make a copy for review by the officer's chain of command and complete a Supervisor's Use of Force Report. The reviewing supervisor must review the use of the TASER and make a recommendation on whether the use of the TASER was justified or not. A copy of the approved police report and completed Use of Force Report will be forwarded to the Chief of Police via the chain of command. The incident will be reviewed in accordance with Policies 300 and 301.

**Justifiable:** When the circumstances, at the time of using the TASER, were consistent with the provisions of this Policy, the use of the device shall be classified as justifiable.

# Bay Area Rapid Transit Police Department

## Policy Manual

### *Conducted Electrical Weapon - TASER*

---

**Unjustifiable:** When the circumstances, at the time of using the TASER, were not consistent with the provisions of this Policy, the use of the device shall be classified as unjustifiable.

The Professional Standards and Training Division Deputy Chief will forward the police report and Use of Force Report to the Chief of Police for review. The Chief of Police will forward the report and signed Use of Force Report to the Internal Affairs Section who will log the report and send it and the Supervisor's Use of Force report to the Use of Force Review Committee Chairperson.

Negligent or unintentional activations of a TASER cartridge shall be reported immediately to a supervisor. The incident shall not be documented as a use of force. The incident shall be documented in a memo, via the chain of command to the Division Deputy Chief to which the employee reports. This memo will include the TASER and cartridge serial numbers and an explanation of the circumstances surrounding the activations. Officers responsible for accidental, unintentional or unjustifiable discharges shall be subject to progressive discipline. Negligent activations shall be included in the Department's Early Intervention system.

#### 309.8 MEDICAL TREATMENT

Only qualified medical personnel, including certified paramedics, should remove TASER darts from a person's body. Used TASER darts shall be considered a sharp biohazard, similar to a used hypodermic needle. Universal precautions should be taken accordingly.

All detained or arrested persons who have been struck by TASER darts or who have been subjected to the electric discharge of the device shall be transported, by medical personnel, for medical assessment at a local medical facility as soon as practicable.

Special consideration (including enhanced observation and a Code 3 medical response) should be provided to individuals who fall under any of the following categories:

- (a) The person is suspected of being under the influence of a controlled substance(s) and/or alcohol
- (b) The person may be pregnant
- (c) The person reasonably appears to be in need of medical attention
- (d) The TASER darts are lodged in a sensitive area (e.g., groin, female breast, near the eyes)
- (e) The person requests medical treatment

In addition, persons who exhibit extreme agitation, violent irrational behavior accompanied by profuse sweating, extraordinary strength beyond physical characteristics, imperviousness to pain, or who require a protracted physical encounter with multiple officers to bring them under control, may be at an increased risk of sudden death and should be examined by qualified medical personnel as soon as practicable (a Code 3 medical response). All individuals shall be medically cleared, prior to booking.

If any person subjected to an unintentional application refuses medical attention, such a refusal should, absent extenuating circumstances, be witnessed by medical personnel and shall be fully documented in related reports. If an audio recording is made of the contact or interview with the individual, any refusal should be included.



# Bay Area Rapid Transit Police Department

## Policy Manual

### *Conducted Electrical Weapon - TASER*

---

The transporting officer shall inform any person receiving custody or any person placed in a position of providing care that the individual has been subjected to the application of the TASER.

#### 309.9 TRAINING

In addition to the initial Department approved training required to carry and use a TASER, annual training will be provided to all sworn personnel. A reassessment of an officer's knowledge and/or practical skills may be required at any time if deemed appropriate.

A certified TASER instructor should ensure that TASER training material and lesson plans include the following:

- (a) A review of this Policy
- (b) A review of the Use of Force Policy 300
- (c) Target area considerations, to include techniques or options to reduce the intentional application of probes near the head, neck, chest, and groin
- (d) De-escalation techniques
- (e) Scenario-based training

#### 309.9.1 **TASER INSTRUCTOR TRAINING**

The below, listed training is from the Department's Training Plan and is either mandatory, essential, or desirable (the Training Plan is located within the G:/drive, Training Unit folder):

- Mandatory TASER training - Basic instructor course
- Desirable TASER training - TASER armorer certification course, advanced instructor course

#### 309.9.2 **REMEDIAL TRAINING**

Any employee who acts in a grossly unsafe manner or demonstrates dangerous and/or extremely poor decision-making skills in the deployment of and/or application of any use-of-force related task (in the field or in training) shall be required to attend mandatory remedial training prior to returning to full-duty status.

If, in the opinion of the supervisor/primary instructor at the site of the training, the employee's decision making and actions are so unsafe that if returned to full duty he/she may be a safety hazard to him or herself, fellow employees, and/or the public, the supervisor/primary instructor shall recommend additional mandatory remedial training for the employee. The primary instructor shall contact the on-duty Watch Commander as soon as practicable and make the recommendation for additional mandatory remedial training.

If the request for additional training is approved, the employee shall be removed from an on-duty patrol status and placed into a temporary administrative position until such time as that employee satisfactorily completes the mandatory remedial training.

Repeated failures to correct such deficiencies may result in implementation of the Progressive Discipline System, similar to Policy Section 461.5.1. Nothing in this Policy precludes the Department from requiring an employee to successfully complete remedial training to correct lesser safety violations and/or marginal tactical decision-making skills, without the employee first being removed from full-duty status.

Bay Area Rapid Transit Police Department  
Policy Manual

*Conducted Electrical Weapon - TASER*

---

309.10 TASER® X26 NOMENCLATURE

- 1 - Probes
- 2 - AFID Tags
- 3 - TASER Cartridge
- 4 - Mechanical Sight
- 5 - Serial Number Plate
- 6 - Illumination Selector Switch
- 7 - Safety Switch
- 8 - Central Information Display (CID)
- 9 - DPM Release Button
- 10 - Stainless Steel Shock Plate
- 11 - Digital Power Magazine (DPM)
- 12 - Trigger
- 13 - Low Intensity Lights (LIL)
- 14 - Built-in Laser (pointing to beam)



## ~~Electronic Control Device~~ Conducted Electrical Weapon (TASER) ~~TASER~~

### 309.1 PURPOSE AND SCOPE

~~The Conducted Electrical Weapon (CEW) is~~ The purpose of this policy is to provide direction on what constitutes the appropriate and authorized use of conducted electrical weapons. ~~a less lethal device which is intended to temporarily incapacitate or stun a violent or potentially violent individual without causing serious injury. It is anticipated that the appropriate use of such a device will result in fewer serious injuries to officers and suspects.~~

#### 309.1.12 DEFINITIONS

**Conducted Electrical Weapon (CEW)** - a device that uses electricity to temporarily incapacitate, stun, or apply pain to an individual in order to overcome resistance.

**Verbal Warning Reference** - Any verbal notification to a subject(s) and/or nearby officers that an officer will activate a CEW.

**Deployment** - Removal of the CEW from the holster, regardless of where the CEW is held or pointed.

**Activation** - Depressing the trigger of the CEW causing an arc of electricity and/or the firing of the probes.

(For report writing purposes and supervisory response, exceptions to activation reporting are Department training and spark and maintenance tests).

#### ~~309.2~~ 309.3 POLICY EQUIPMENT

The only CEW authorized and issued by this Department is the TASER® X26. All sworn personnel shall receive Department-approved training and may be issued a TASER for use during their current assignment. **No officer is authorized to deploy or activate a TASER prior to receiving Department-approved training.**

- (a) A TASER shall be assigned and carried (i.e., worn on the person, as described at the end of this Section) as a part of **each** uniformed officer's and sergeant's equipment, in a holster that is designed to fit the TASER® X26. Employees must request and have the approval of the Chief, or his designee, to *not* carry the TASER as part of their uniform equipment. Non-uniformed officers may secure the TASER in the driver's compartment of their Department vehicle.
- (b) All TASERs shall be clearly and distinctly marked with factory yellow X26 markings on the sides to differentiate them from the duty weapon and any other device.
- (c) Officers should carry a total of two or more TASER cartridges on their person when carrying the TASER. Only Department issued cartridges are authorized.
- (d) Officers shall be responsible for ensuring that their assigned TASER is properly maintained and in good working order at all times. Whenever an assigned TASER is damaged or inoperable, the officer shall immediately notify his/her supervisor and document the specific damage or inoperability issue in a memo sent via the chain

# Bay Area Rapid Transit Police Department

## Policy Manual

### ~~Electronic Control Device~~ Conducted Electrical Weapon - TASER

---

of command to the Support Services Deputy Chief. The notified supervisor shall make an effort to have a reserve TASER assigned to the officer during that shift. Reserve TASERs shall be located in the Watch Commander's cabinet at LMA. The supervisor shall document the damaged TASER's serial number and the assigned officer's name and badge number in an email to the Support Services Lieutenant to facilitate the equipment repair.

~~(d)~~

(e) TASERs shall not be altered from the original factory specifications and markings.

~~(f) Officers should not hold both a firearm and the TASER at the same time unless lethal force is justified.~~

OIPA Policy Recommendation - BPD Policy 309 (Marked Version)

# Bay Area Rapid Transit Police Department

## Policy Manual

### ~~Electronic Control Device Conducted Electrical Weapon - TASER~~

---

- (g)(f) Officers who locate a broken cartridge or have an unintentional discharge shall forward the cartridge to a Department TASER armorer. It should be loosely packaged and sealed in a brown evidence bag.
- (h)(g) TASERS with a battery life of 20% or less shall be removed from service. These TASERS should be forwarded to the Support Services Lieutenant for battery replacement.
- (i)(h) The Support Services Lieutenant will ensure that TASER armorers conduct annual TASER memory downloads for all TASERS.
- ~~(j) Due to the flammable contents in some chemical agent containers, officers shall only carry Department issued Oleoresin Capsicum (OC), which is water based and will not ignite.~~

There are two authorized ways for officers to carry the TASER:

- In a holster, opposite side from the duty weapon with no portion of the TASER crossing the mid-line of the officer's belt when it is holstered. When carried in this manner, the officer shall use a support-hand draw only.
- In a drop leg holster, worn on the support hand side only (opposite the duty weapon). When carried in this manner, the officer shall use a support-hand draw only.

#### ~~309.3309.4~~ USE OF THE TASER

It is the policy of this Department that an officer shall use only that amount of force which is objectively reasonable in light of the facts and circumstances confronting the officer at the time of the event giving rise to the use of force. Activation of the TASER is, at all times, subject to this standard. Each individual activation of the TASER, even during the same incident, becomes a separate use of force and must be objectively reasonable. In some cases, other control techniques may be more appropriate as determined by the subject's degree of resistance and/or threat level to others.

Subject to the objective reasonableness standard, an officer generally may activate the TASER when grounds to arrest or detain are present, and the subject:

- Uses force or attempts to use force against the officer or another person
- Physically resists the arrest or detention or demonstrates an intention to physically resist (such as the assumption of a fighting stance)
- Refuses to comply with verbal orders without any physical resistance or demonstrated intention to physically resist, but is believed to be armed
- Flees in order to evade arrest or detention and presents an imminent or immediate threat to the officer or other individuals

Officers may also generally activate the TASER to subdue a vicious animal that presents a danger to the officer or other individuals.

Similarly subject to the objective reasonableness standard, an officer generally may not activate the TASER when the subject:

- Refuses to comply with verbal orders without any physical resistance or demonstrated intention to physically resist, and is not believed to be armed

# Bay Area Rapid Transit Police Department

## Policy Manual

### ~~Electronic Control Device~~ Conducted Electrical Weapon - TASER

- Flees in order to evade arrest or detention but does not present an imminent or immediate threat to the officer or other individuals

Although not absolutely prohibited, officers should avoid, absent extenuating circumstances, applying the TASER to any of the following individuals:

- (a) Pregnant females
- (b) Elderly individuals, obvious juveniles, or the visibly frail
- (c) Individuals who have been recently sprayed with alcohol-based pepper spray or potentially flammable chemical agents, or who are otherwise in close proximity to any combustible material
- (d) Individuals whose position or activity may result in collateral injury (e.g., falls from height, operating vehicles)
- (e) Handcuffed persons, unless they pose an immediate threat of great bodily injury to themselves or others
- (f) Subjects who are in control of a vehicle in motion (including automobiles, motorcycles and bicycles).
- (g) Individuals suspected of being under the influence of drugs/alcohol or exhibiting symptoms of excited delirium (e.g., nudity, profuse sweating, irrational behavior, extraordinary strength beyond physical characteristics or imperviousness to pain). These subjects may be more susceptible to collateral problems and should be closely monitored (e.g., breathing pattern) following the application of the TASER until they can be examined by paramedics or other medical personnel.

Officers should not hold both a firearm and the TASER at the same time unless lethal force is justified. The TASER shall never be used:

- (a) To torture, psychologically torment, or inflict undue pain on any individual
- (b) As a prod or escort device
- (c) To rouse unconscious, impaired, or intoxicated individuals

In addition to the specific circumstances listed above, all evaluations of a use of force subject to the objective reasonableness standard may take into account a number of factors including, but not limited to:

- (a) The conduct of the individual being confronted (as reasonably perceived by the officer at the time)
- (b) Officer/subject factors (i.e., age, size, relative strength, skill level, injury/exhaustion, number of officers vs. subjects)
- (c) Influence of drugs/alcohol (mental capacity)
- (d) Proximity of weapons
- (e) The degree to which the subject has been effectively restrained and his/her ability to resist, despite being restrained
- (f) Time and circumstances permitting, the availability of other options (what resources are reasonably available to the officer under the circumstances)
- (g) Seriousness of the suspected offense or the reason for contact with the individual

# Bay Area Rapid Transit Police Department

## Policy Manual

### ~~Electronic Control Device~~ Conducted Electrical Weapon - TASER

---

- (h) Training and experience of the officer
- (i) Potential for injury to citizens, officers, and suspects
- (j) Risk of escape
- (k) Other exigent circumstances

#### **309.4.1 ADDITIONAL CONSIDERATIONS**

It is essential that officers exercise sound discretion and consider the totality of the circumstances surrounding any incident where the TASER may be activated. Objective facts must indicate the suspect poses an immediate threat to the officer or a member of the public.

As with any law enforcement equipment, the TASER has limitations and restrictions requiring consideration before its use. The TASER should only be used when its operator can safely approach the subject within the operational range of the TASER. Although the TASER rarely fails and is generally effective in subduing most individuals, ~~Officers~~ officers should be aware of ~~this~~ the potential that a TASER will fail to subdue an individual, and they should be prepared with other options in the unlikely event of such a failure.

OIPA Policy Recommendation - BPD Policy 309.4.1 (New Version)

# Bay Area Rapid Transit Police Department

## Policy Manual

### ~~Electronic Control Device Conducted Electrical Weapon - TASER~~

---

Every application of the TASER becomes a separate use of force and must be justified by the officer. In instances where a warning is provided prior to the use of the TASER, the subject must be given reasonable time to comply.

If, after a single application of the TASER, an officer is still unable to gain compliance from an individual and circumstances allow, the officer should consider:

- (a) Whether or not the probes are making proper contact
- (b) Whether use of the TASER is limiting the ability of the individual to comply
- (c) Whether other options or tactics may be more appropriate

This, however, shall not preclude an officer from multiple, reasonable applications of the TASER on an individual. When probes are in contact with the individual or when drive stun mode is in contact with the individual, no more than three activations should be administered on the same individual. The TASER should not be intentionally activated at the subject's head, neck, chest, or groin.

Authorized personnel may use the TASER when circumstances known to the individual officer at the time indicate that the application of the TASER is reasonable to subdue or control:

- (a) A violent or physically resisting subject.
- (b) A potentially violent or physically resisting subject, if:
  1. The subject has verbally or physically demonstrated an intention to resist; and
  2. The officer is able to justify that the use is based upon an objectively reasonable belief that a suspect poses an immediate threat to the officer or others; and
  3. The officer has given the subject a verbal warning of the intended use of the TASER followed by a reasonable opportunity to voluntarily comply; and
  4. Other available options reasonably appear ineffective or would present a greater danger to the officer or subject.
- (c) A vicious animal that appears to present a danger to the officer or the public.

Although not absolutely prohibited officers should avoid, absent extenuating circumstances, applying the TASER to any of the following individuals:

- (a) Pregnant females
- (b) Elderly individuals, obvious juveniles, or the visibly frail
- (c) Individuals who have been recently sprayed with alcohol-based pepper spray or potentially flammable chemical agents, or who are otherwise in close proximity to any combustible material
- (d) Individuals whose position or activity may result in collateral injury (e.g., falls from height, operating vehicles)
- (e) Handcuffed persons, unless they pose an immediate threat of great bodily injury to themselves or others
- (f) Fleeing subjects (fleeing should not be the sole justification for activating a TASER against a subject; personnel should consider the severity of the offense, the subject's threat level to others, and the risk of serious injury to the subject before deciding to



# Bay Area Rapid Transit Police Department

## Policy Manual

~~Electronic Control Device~~ ~~Conducted Electrical Weapon~~ - TASER

use a TASER on a fleeing subject

OIPA Policy Recommendation - BPD Policy 309 (Marked Version)

# Bay Area Rapid Transit Police Department

## Policy Manual

### ~~Electronic Control Device~~ Conducted Electrical Weapon - TASER

- ~~(g) Subjects who are simply non-compliant or who are in control of a vehicle in motion (including automobiles, motorcycles and bicycles).~~
- ~~(h) Individuals suspected of being under the influence of drugs/alcohol or exhibiting symptoms of excited delirium (e.g., nudity, profuse sweating, irrational behavior, extraordinary strength beyond physical characteristics or imperviousness to pain). These subjects may be more susceptible to collateral problems and should be closely monitored (e.g., breathing pattern) following the application of the TASER until they can be examined by paramedics or other medical personnel.~~

~~Personnel should evaluate whether the use of the TASER is reasonable, based upon all circumstances (including those listed above); if the TASER is used, the officer will be required to justify why the level of resistance or threat necessitated its use (e.g., potential for violence, nature of crime, proximity of weapons, etc.). In some cases, other control techniques may be more appropriate as determined by the subject's degree of resistance and/or threat level to others.~~

~~Because the application of the TASER in the drive stun mode (i.e., direct contact without darts) relies primarily on pain compliance and requires close proximity to the subject, the controlling effects may be limited. Additional caution should be exercised.~~

~~When the probes are in contact with a person, no more than one officer should intentionally activate a TASER against that person.~~

~~The TASER shall not be used:~~

- ~~• To torture, psychologically torment, or inflict undue pain on any individual~~
- ~~• As a prod or escort device~~
- ~~• To rouse unconscious, impaired, or intoxicated individuals~~

### 309.4309.5 VERBAL AND VISUAL WARNINGS

Unless it would otherwise endanger officer safety or is impractical due to circumstances, a verbal ~~announcement~~ **warning** of the intended use of the TASER shall precede its application in order to:

- (a) Provide the individual with a reasonable opportunity to voluntarily comply
- (b) Provide other officers and individuals with warning that a TASER may be activated

**In instances where a verbal warning is provided prior to the use of the TASER, the subject must be given reasonable time to comply.**

If after a verbal warning an individual continues to express an unwillingness to voluntarily comply with an officer's lawful orders, and it appears both reasonable and practical under the circumstances, the officer may, but is not required to, display the electrical arc (provided there is not a cartridge loaded into the TASER) or **built-in** laser in a further attempt to gain compliance prior to the application of the TASER. The ~~aiming~~ laser should never be intentionally directed into the eyes of another as it may permanently impair his/her vision.

The fact that a verbal and/or other warning was given, or reasons a warning was not given, shall be documented in any related reports.

# Bay Area Rapid Transit Police Department

## Policy Manual

### ~~Electronic Control Device~~ ~~Conducted Electrical Weapon~~ - TASER

---

#### ~~309.5~~ ~~USE OF THE TASER~~

~~It is essential that officers exercise sound discretion and consider the totality of the circumstances surrounding any incident where the TASER may be activated. Objective facts must indicate the suspect poses an immediate threat to the officer or a member of the public.~~

~~As with any law enforcement equipment, the TASER has limitations and restrictions requiring consideration before its use. The TASER should only be used when its operator can safely approach the subject within the operational range of the TASER. Although the TASER rarely fails and is generally effective in subduing most individuals, officers should be aware of this potential and be prepared with other options in the unlikely event of such a failure.~~

OIPA Policy Recommendation - BPD Policy 309 (Marked for Deletion)

# Bay Area Rapid Transit Police Department

## Policy Manual

### ~~Electronic Control Device~~ ~~Conducted Electrical Weapon~~ - TASER

~~Every application of the TASER becomes a separate use of force and must be justified by the officer. In instances where a warning is provided prior to the use of the TASER, the subject must be given reasonable time to comply.~~

~~If, after a single application of the TASER, an officer is still unable to gain compliance from an individual and circumstances allow, the officer should consider:~~

- ~~• Whether or not the probes are making proper contact~~
- ~~• If use of the TASER is limiting the ability of the individual to comply~~
- ~~• If other options or tactics may be more appropriate~~

~~This, however, shall not preclude an officer from multiple, reasonable applications of the TASER on an individual. When probes are in contact with the individual or when drive stun mode is in contact with the individual, no more than three activations should be administered on the same individual. The TASER should not be intentionally activated at the subject's head, neck, chest, or groin.~~

~~Authorized personnel may use the TASER when circumstances known to the individual officer at the time indicate that the application of the TASER is reasonable to subdue or control:~~

- ~~(d) A violent or physically resisting subject.~~
- ~~(e) A potentially violent or physically resisting subject, if:
  - ~~1. The subject has verbally or physically demonstrated an intention to resist; and~~
  - ~~2. The officer is able to justify that the use is based upon an objectively reasonable belief that a suspect poses an immediate threat to the officer or others; and~~
  - ~~3. The officer has given the subject a verbal warning of the intended use of the TASER followed by a reasonable opportunity to voluntarily comply; and~~
  - ~~4. Other available options reasonably appear ineffective or would present a greater danger to the officer or subject.~~~~
- ~~(f) A vicious animal that appears to present a danger to the officer or the public.~~

~~Although not absolutely prohibited officers should avoid, absent extenuating circumstances, applying the TASER to any of the following individuals:~~

- ~~(i) Pregnant females~~
- ~~(j) Elderly individuals, obvious juveniles, or the visibly frail~~
- ~~(k) Individuals who have been recently sprayed with alcohol based pepper spray or potentially flammable chemical agents, or who are otherwise in close proximity to any combustible material~~
- ~~(l) Individuals whose position or activity may result in collateral injury~~

# Bay Area Rapid Transit Police Department

## Policy Manual

### ~~Electronic Control Device Conducted Electrical Weapon - TASER~~

---

~~(e.g., falls from height, operating vehicles)~~

~~(m) Handcuffed persons, unless they pose an immediate threat of great bodily injury to themselves or others~~

~~(n) Fleeing subjects (fleeing should not be the sole justification for activating a TASER against a subject; personnel should consider the severity of the offense, the subject's threat level to others, and the risk of serious injury to the subject before deciding to use a TASER on a fleeing subject)~~

OIPA Policy Recommendation - BPD Policy 309 (Marked Version)

# Bay Area Rapid Transit Police Department

## Policy Manual

### ~~Electronic Control Device Conducted Electrical Weapon - TASER~~

- ~~(o) Subjects who are simply non-compliant or who are in control of a vehicle in motion (including automobiles, motorcycles and bicycles).~~
- ~~(p) Individuals suspected of being under the influence of drugs/alcohol or exhibiting symptoms of excited delirium (e.g., nudity, profuse sweating, irrational behavior, extraordinary strength beyond physical characteristics or imperviousness to pain). These subjects may be more susceptible to collateral problems and should be closely monitored (e.g., breathing pattern) following the application of the TASER until they can be examined by paramedics or other medical personnel.~~

~~Personnel should evaluate whether the use of the TASER is reasonable, based upon all circumstances (including those listed above); if the TASER is used, the officer will be required to justify why the level of resistance or threat necessitated its use (e.g., potential for violence, nature of crime, proximity of weapons, etc.). In some cases, other control techniques may be more appropriate as determined by the subject's degree of resistance and/or threat level to others.~~

~~Because the application of the TASER in the drive-stun mode (i.e., direct contact without darts) relies primarily on pain compliance and requires close proximity to the subject, the controlling effects may be limited. Additional caution should be exercised.~~

~~When the probes are in contact with a person, no more than one officer should intentionally activate a TASER against that person.~~

~~The TASER shall not be used:~~

- ~~• To torture, psychologically torment, or inflict undue pain on any individual~~
- ~~• As a prod or escort device~~
- ~~• To rouse unconscious, impaired, or intoxicated individuals~~

#### ~~309.4.1 FACTORS TO DETERMINE REASONABLENESS OF FORCE~~

~~The application of the TASER is likely to cause intense, momentary pain. As such, officers should carefully consider and balance the totality of circumstances available prior to using the TASER including, but not limited to, the following factors:~~

- ~~(a) The conduct of the individual being confronted (as reasonably perceived by the officer at the time)~~
- ~~(b) Officer/subject factors (i.e., age, size, relative strength, skill level, injury/exhaustion, number of officers vs. subjects)~~
- ~~(c) Influence of drugs/alcohol (mental capacity)~~
- ~~(d) Proximity of weapons~~
- ~~(e) The degree to which the subject has been effectively restrained and his/her ability to resist, despite being restrained~~
- ~~(f) Time and circumstances permitting, the availability of other options (what resources are reasonably available to the officer under~~

# Bay Area Rapid Transit Police Department

## Policy Manual

### ~~Electronic Control Device Conducted Electrical Weapon - TASER~~

---

~~the circumstances)~~

~~(g) Seriousness of the suspected offense or the reason for contact with the individual~~

~~(h) Training and experience of the officer~~

~~(i) Potential for injury to citizens, officers, and suspects~~

~~(j) Risk of escape~~

~~(k) Other exigent circumstances~~

OIPA Policy Recommendation - BPD Policy 309 (Marked Version)

# Bay Area Rapid Transit Police Department

## Policy Manual

### ~~Electronic Control Device~~ Conducted Electrical Weapon - TASER

---

#### ~~309.4.2~~ 309.6 REPORT OF ~~TASER~~ USE

It is essential that officers exercise sound discretion and carefully articulate the totality of the circumstances giving rise to every TASER application. Verbal warnings, deployments, and TASER activations shall be documented in the related crime report. The TASER tab in the MO data entry section of the report writing program shall be utilized to document the type of usage (verbal, deployment, or activation). The incident shall be thoroughly documented in the narrative of the police report.

When the TASER is activated the police report should include the following:

- (a) Details of the subject's level of aggression justifying activation
- (b) Number and approximate duration of cycle(s)
- (c) Point of impact of the probes and/or drive stun mode on a subject
- (d) Response and actions of the subject after activation
- (e) Number of officers on scene
- (f) Names of individuals who provided medical care on scene and the names of medical personnel who removed the probes
- (g) Serial numbers of the TASER and cartridge
- (h) Photographic evidence, to include the subject prior to and after probe removal, the drive stun contact point, and any injuries incurred by the subject or officer as result of the incident
- (i) Name of the person receiving custody of the subject and advised of the TASER activation on the subject

Supplemental reports shall be completed by personnel who are present during ~~ana~~ ~~TASER~~ activation.

A TASER armorer shall download the on-board TASER memory and save it with the related crime report; the on-scene supervisor is responsible for assigning this task. TASERs will not be taken out of service after an activation unless directed by a command-level officer.

#### ~~309.4.3~~ 309.7 SUPERVISORY RESPONSIBILITY

A supervisor shall respond to the scene of any ~~CEW-TASER~~ activation including negligent or unintentional activations. The supervisor shall confirm (with the officer) that any probes that have pierced a subject's skin are removed by medical personnel and that the subject is medically cleared, as outlined in Section 309.58, prior to being booked into a detention facility. The supervisor will confirm that all evidence (including the ~~CEW's-TASER's~~ memory record) has been collected, review and approve the related crime reports, and provide a replacement ~~CEW-TASER~~ cartridge(s) as necessary.

Upon reviewing the report, the supervisor must make a copy for review by the officer's chain of command and complete a Supervisor's Use of Force Report. The reviewing supervisor must review the use of the ~~CEW-TASER~~ and make a recommendation on whether the use of the ~~CEW-TASER~~ was justified or not. A copy of the approved police report and completed Use of Force Report will be forwarded to the Chief of Police via the chain of command. The incident will be reviewed in accordance with Policies 300 and 301.

**Justifiable:** When the circumstances, at the time of using the ~~CEW~~TASER, were consistent with the provisions of this Policy, the use of the device shall be classified as



# Bay Area Rapid Transit Police Department

## Policy Manual

~~Electronic Control Device~~ **Conducted Electrical Weapon - TASER**

---

justifiable.

**Unjustifiable:** When the circumstances, at the time of using the ~~CEW~~**TASER**, were not consistent with the provisions of this Policy, the use of the device shall be classified as unjustifiable.

OIPA Policy Recommendation - BPD Policy 309 (Marked Version)

# Bay Area Rapid Transit Police Department

## Policy Manual

### ~~Electronic Control Device~~ Conducted Electrical Weapon - TASER

---

The Professional Standards and Training Division Deputy Chief will forward the police report and Use of Force Report to the Chief of Police for review. The Chief of Police will forward the report and signed Use of Force Report to the Internal Affairs Section who will log the report and send it and the Supervisor's Use of Force report to the Use of Force Review Committee Chairperson.

Negligent or unintentional activations of a ~~CEW-TASER~~ cartridge shall be reported immediately to a supervisor. The incident shall not be documented as a use of force. The incident shall be documented in a memo, via the chain of command to the Division Deputy Chief to which the employee reports. This memo will include the ~~CEW-TASER~~ and cartridge serial numbers and an explanation of the circumstances surrounding the activations. Officers responsible for accidental, unintentional or unjustifiable discharges shall be subject to progressive discipline. Negligent activations shall be included in the Department's Early Intervention system.

#### ~~309.5309.8~~ MEDICAL TREATMENT

Only qualified medical personnel, including certified paramedics, should remove TASER darts from a person's body. Used TASER darts shall be considered a sharp biohazard, similar to a used hypodermic needle. Universal precautions should be taken accordingly.

All detained or arrested persons who have been struck by TASER darts or who have been subjected to the electric discharge of the device shall be transported, by medical personnel, for medical assessment at a local medical facility as soon as practicable.

Special consideration (including enhanced observation and a Code 3 medical response) should be provided to individuals who fall under any of the following categories:

- (a) The person is suspected of being under the influence of a controlled substance(s) and/or alcohol
- (b) The person may be pregnant
- (c) The person reasonably appears to be in need of medical attention
- (d) The TASER darts are lodged in a sensitive area (e.g., groin, female breast, near the eyes)
- (e) The person requests medical treatment

In addition, persons who exhibit extreme agitation, violent irrational behavior accompanied by profuse sweating, extraordinary strength beyond physical characteristics, imperviousness to pain, or who require a protracted physical encounter with multiple officers to bring them under control, may be at an increased risk of sudden death and should be examined by qualified medical personnel as soon as practicable (a Code 3 medical response). All individuals shall be medically cleared, prior to booking.

If any person subjected to an unintentional application refuses medical attention, such a refusal should, absent extenuating circumstances, be witnessed by medical personnel and shall be fully documented in related reports. If an audio recording is made of the contact or interview with the individual, any refusal should be included.

The transporting officer shall inform any person receiving custody or any person placed in a position of providing care that the individual has been subjected to the application of the TASER.

# Bay Area Rapid Transit Police Department

## Policy Manual

### ~~Electronic Control Device~~ Conducted Electrical Weapon - TASER

---

#### ~~309.6.3~~ 309.9 TRAINING

In addition to the initial Department approved training required to carry and use a TASER, annual training will be provided to all sworn personnel. A reassessment of an officer's knowledge and/or practical skills may be required at any time if deemed appropriate.

A certified TASER instructor should ensure that TASER training material and lesson plans include the following:

- (a) A review of this Policy
- (b) A review of the Use of Force Policy 300
- (c) Target area considerations, to include techniques or options to reduce the intentional application of probes near the head, neck, chest, and groin
- (d) De-escalation techniques
- (e) Scenario-based training

#### ~~309.6.1~~ 309.9.1 **TASER INSTRUCTOR TRAINING**

The below, listed training is from the Department's Training Plan and is either mandatory, essential, or desirable (the Training Plan is located within the G:/drive, Training Unit folder):

- Mandatory TASER training - Basic instructor course
- Desirable TASER training - TASER armorer certification course, advanced instructor course

#### ~~309.6.2~~ 309.9.2 **REMEDIAL TRAINING**

Any employee who acts in a grossly unsafe manner or demonstrates dangerous and/or extremely poor decision-making skills in the deployment of and/or application of any use-of-force related task (in the field or in training) shall be required to attend mandatory remedial training prior to returning to full-duty status.

If, in the opinion of the supervisor/primary instructor at the site of the training, the employee's decision making and actions are so unsafe that if returned to full duty he/she may be a safety hazard to him or herself, fellow employees, and/or the public, the supervisor/primary instructor shall recommend additional mandatory remedial training for the employee. The primary instructor shall contact the on-duty Watch Commander as soon as practicable and make the recommendation for additional mandatory remedial training.

If the request for additional training is approved, the employee shall be removed from an on-duty patrol status and placed into a temporary administrative position until such time as that employee satisfactorily completes the mandatory remedial training.

Repeated failures to correct such deficiencies may result in implementation of the Progressive Discipline System, similar to Policy Section 461.5.1. Nothing in this Policy precludes the Department from requiring an employee to successfully complete remedial training to correct lesser safety violations and/or marginal tactical decision-making skills, without the employee first being removed from full-duty status.

#### 309.10 ~~309.7~~ TASER® X26 NOMENCLATURE

- 1 - Probes

# Bay Area Rapid Transit Police Department

## Policy Manual

### ~~Electronic Control Device~~ Conducted Electrical Weapon - TASER

---

- 2 - AFID Tags
- 3 - TASER Cartridge

OIPA Policy Recommendation - BPD Policy 309 (Marked Version)

# Bay Area Rapid Transit Police Department

## Policy Manual

### ~~Electronic Control Device~~ Conducted Electrical Weapon - TASER

---

- 4 - Mechanical Sight
- 5 - Serial Number Plate
- 6 - Illumination Selector Switch
- 7 - Safety Switch
- 8 - Central Information Display (CID)
- 9 - DPM Release Button
- 10 - Stainless Steel Shock Plate
- 11 - Digital Power Magazine (DPM)
- 12 - Trigger
- 13 - Low Intensity Lights (LIL)
- 14 - Built-in Laser (pointing to beam)

