

CITY OF SUNNYVALE

SINGLE-FAMILY CONSTRUCTION STANDARDS



June 2015

INTRODUCTION

The City of Sunnyvale has an international reputation for our streamlined building permit process and customer service. We were the first city in the country to provide a centralized building permit center for customer convenience. Established in 1984, the One-Stop Permit Center provides a single location where information is available for construction and development projects and where permits can be issued.

The One-Stop Permit Center is located at City Hall, 456 W. Olive Avenue and is generally open from 8:00 a.m. to 5:00 p.m. Monday through Friday (except holidays). Following is a list of specific department availability:

Building Safety, Planning, and Public Works	8:00 a.m. - 5:00 p.m.
Fire Prevention	8:00 a.m. - 1:00 p.m.
Structural Engineering	8:30 a.m. - 1:00 p.m.

This book is designed to assist contractors and homeowners with guidelines and standard requirements for various types of repairs, remodels, additions, and new construction of individual single family homes. For additional questions or specific project information, please contact the Community Development Department at:

Telephone	(408) 730-7444
Building Division web site	www.SunnyvaleBuilding.com
Planning Division web site	www.SunnyvalePlanning.com

In 1999, the City of Sunnyvale was also one of the first cities in the nation to offer building permit services on-line at the E-OneStop (www.e-onestop.net). The E-OneStop offers the following services, all available on demand 24/7:

- **E-Permits** - Obtain 17 various types of residential building permits on-line.
- **Permit Histories** - Find permit histories for both planning and building permits.
- **Plan Check Status** - View the status of plan checks and comments.
- **Inspection Scheduling** - Schedule building inspections on-line.
- **Zoning Information** - Get zoning, lot size, and flood zone for any property in Sunnyvale.

We continue to look for opportunities to improve our services and welcome suggestions from our customers. If you have any questions or comments, please contact us at (408) 730-7444 or building@sunnyvale.ca.gov.



Ali Fatapour, Chief Building Official

TABLE OF CONTENTS

INTRODUCTION	I
TABLE OF CONTENTS	III
OVERVIEW	1
ZONING AND LAND USE	1
CONSTRUCTION CODES	1
DEFINITIONS	2
RESIDENTIAL ZONING STANDARDS	3
<i>Rear Yard Setback Exception</i>	5
<i>Vision Triangles</i>	5
ALLOWABLE HOURS OF CONSTRUCTION	6
PERMITS, PLAN CHECKS, AND FEES	9
PLANNING PERMITS AND PROCESSING	9
BUILDING PERMITS, PLAN CHECKS, AND INSPECTIONS	9
<i>Work Exempt from Requiring a Building Permit</i>	9
<i>Plan Check</i>	11
<i>Inspections</i>	12
FIRE SPRINKLER PERMITS, PLAN CHECKS, AND INSPECTIONS	14
FEES	14
NEW CONSTRUCTION, ADDITIONS, AND INTERIOR REMODEL STANDARDS	17
ZONING STANDARDS FOR NEW SINGLE FAMILY HOMES AND ADDITIONS TO EXISTING SINGLE FAMILY HOMES	17
<i>Design Review</i>	17
<i>Parking</i>	17
<i>Solar Access</i>	18
GREEN BUILDING PROGRAM	18
WATER EFFICIENT LANDSCAPING AND IRRIGATION	19
WATER EFFICIENT PLUMBING FIXTURES	19
RESIDENTIAL AUTOMATIC FIRE SPRINKLERS	20
SMOKE AND CARBON MONOXIDE ALARMS	20
FLOOD ZONES	21
EXTERIOR IMPROVEMENTS AND ACCESSORY BUILDING/STRUCTURE STANDARDS	23
ACCESSORY LIVING UNITS	23
ACCESSORY STRUCTURES (SHEDS, DECKS, ETC.)	24
<i>Structure Types</i>	24
<i>General Information</i>	24
<i>Planning Permits</i>	25
<i>Setbacks</i>	25
<i>Additional Requirements</i>	26
<i>Patio Cover Standard Construction Detail</i>	26

FENCES.....	27
<i>Fence Standard Construction Detail</i>	29
POOLS, PONDS, AND OUTDOOR SPAS	29
PHOTOVOLTAIC PANELS.....	32
ANTENNAS AND SATELLITE DISHES.....	33
TREE REMOVAL	33
CONSTRUCTION STANDARDS AND DETAILS	35
FRAMING AND FOUNDATION CONSTRUCTION	35
<i>Quality of Lumber</i>	35
<i>Nailing Schedule</i>	35
<i>Foundations</i>	37
<i>Floor Construction</i>	38
<i>Wall Framing</i>	39
<i>Roofs</i>	40
<i>Roof Construction</i>	42
<i>Roof Covering</i>	42
<i>Exterior Doors and Garage Doors</i>	44
<i>Exterior Wall Coverings</i>	45
<i>Skylights</i>	46
<i>Fireplaces and Chimneys</i>	47
INTERIOR SPACE REQUIREMENTS.....	51
<i>Fire-Resistive Construction Between a Dwelling and Garage</i>	51
<i>Windows</i>	51
<i>Light and Ventilation</i>	53
<i>Interior Space Dimensions</i>	54
<i>Stairways</i>	55
<i>Guardrails</i>	57
<i>Wallboard</i>	58
<i>Clothes Dryer Ventilation</i>	59
ELECTRICAL REQUIREMENTS.....	59
<i>Installation of Electrical Service</i>	59
<i>Receptacle Installation</i>	62
<i>Lighting</i>	64
<i>Ground Fault Circuit Interrupter - GFCI</i>	65
<i>Arc Fault Circuit Interrupter - AFCI</i>	66
<i>Electrical Wiring Details</i>	66
<i>Indoor Spas and Hydromassage Bathtubs</i>	68
PLUMBING REQUIREMENTS.....	68
<i>Equipment</i>	68
<i>Installation Standards</i>	68
<i>Water Supply</i>	68
<i>Water Heaters</i>	69
<i>Irrigation Sprinklers</i>	71
<i>Bathtubs and Showers</i>	71
<i>Building Sewers/Drainage System</i>	71
GAS PIPING	72
SPACE HEATING AND COOLING REQUIREMENTS.....	74
<i>Equipment</i>	74
<i>Installation Locations</i>	74
<i>Combustion Air</i>	74
<i>Heating System</i>	75

<i>Air Conditioning System</i>	75
<i>Venting of Appliances</i>	76
<i>Ducts</i>	76
<i>Means of Disconnect</i>	76
<i>Service Receptacle</i>	76
<i>Illumination</i>	76
<i>Equipment Located in a Garage</i>	76
<i>Equipment Located in an Attic</i>	77
ENERGY CONSERVATION REQUIREMENTS	77
<i>Mandatory Measures</i>	78
<i>New Construction and Additions to Existing Buildings</i>	83

APPENDIXA-1

<i>Electrical Load Estimating Worksheet</i>
<i>Typical Single Story Foundation Details</i>
<i>Typical Pier and Interior Footing Details</i>
<i>Typical Girder Detail</i>
<i>General Framing Details</i>
<i>Shear and Framing Details</i>
<i>Typical Two Story Wall Framing</i>
<i>Typical Wall Framing</i>
<i>Typical Section Through Garage</i>
<i>Typical Notching and Boring Details</i>
<i>Typical Framing at Openings</i>

OVERVIEW

Zoning and land use regulations provide for the development of the City in a manner that protects and promotes the public health, safety, peace, comfort and general welfare. In addition, zoning is intended to conserve the value of property, and protect the character and stability of residential, commercial and industrial areas, and promote the orderly and beneficial development of such areas.

A building permit gives you legal permission to start construction of a building project in accordance with approved codes. The purpose of building codes is to establish minimum requirements for structural strength, means of egress facilities, stability, sanitation, light and ventilations, and energy conservation to protect life and property from fire and other hazards.

ZONING AND LAND USE

Title 19 of the Sunnyvale Municipal Code specifies the zoning regulations for the City. Each property is located within a specific zoning district which determines the allowable land use and applicable development standards. Allowable land uses include use type as well as density/intensity of such uses. The development standards regulate building characteristics such as setbacks, lot coverage, building height, etc.

There are eight different residential zoning district types in the city. Each district requires different minimum lot sizes, densities (units per acre), and building setbacks and heights. This book contains general information on the five residential zoning districts that typically contain single family homes. The information provided is intended to assist with remodels and additions to single family homes. For specific information regarding a property, please contact the Planning Division for more detailed information.

CONSTRUCTION CODES

This book contains general building code information for single family residential homes. The information provided is intended to assist with remodels and additions to single family homes as well as new construction. For specific information regarding a property, please contact the Building Division for more specific information. Following are the current editions of the codes adopted by the City of Sunnyvale:

- 2013 California Building Code;
- 2013 California Residential Code;
- 2013 California Mechanical Code;
- 2013 California Plumbing Code;
- 2013 California Electrical Code;
- 2013 California Green Building Standards Code;
- 2013 California Fire Code;
- 2013 Building Energy Efficiency Standards
- 2009 International Property Maintenance Code; and
- Sunnyvale Municipal Code;

DEFINITIONS

The following definitions are provided for clarification of various terms that are used in this section.

Accessory living unit. Any one-bedroom dwelling unit which provides independent provisions for living, sleeping, eating, cooking and sanitation, for one or more persons, and which is structurally attached to the principal dwelling unit by a minimum 10-foot long common load bearing wall, or which is internal to a single-family dwelling sharing the same lot. A mobile home shall not be erected as an accessory living unit.

Accessory structures. A detached subordinate structure, with or without a foundation, the use of which is incidental to that of the main building or to the use of the land on the same lot.

Antenna. Any system, external to or attached to the exterior of any building, consisting of wires, poles, rods, discs or similar devices used for the transmission and/or reception of radio, television or other communication signals.

Antenna, dish. Any antenna, external to or attached to the exterior of any building or structure, which is parabolic or semicircular in cross-section.

Dwelling unit. A single unit providing complete, independent living facilities for one or more persons including permanent provisions for living, sleeping, eating, cooking, and sanitation.

Floor area ratio (FAR). A ratio, expressed as a percentage, of the gross floor area of all buildings (including covered parking) on a given lot, to the net area of the parcel on which such building or buildings are located

Gross floor area. The sum of the areas computed from the outside dimensions of a building. Garages are included in floor area calculations. Basement area may be exempt from the calculation as long as it is located no higher than 2 ft. above grade. Any area with an interior ceiling height exceeding 15 feet shall be counted twice for the purpose of calculating gross floor area. See Sunnyvale Municipal Code section 19.12.080"G" for a complete definition of gross floor area.

Habitable space. A space in a building for living, sleeping, eating, and cooking. Bathrooms, toilet rooms, closets, halls, storage or utility spaces and similar areas are not considered habitable spaces.

Lot coverage. Land area covered by all buildings on a lot. Measurements are taken from the outer walls of each building, including corridors, supporting columns, unsupported wall projections and enclosed or unenclosed patios where the roof is more than 50% solid.

Property line (general location). The property line for the front yard and the reducible front yard is determined in most cases by measuring 11 feet from the face of the curb toward the house.

Reducible front yard. Located only on corner lots, this frontage is the longer of the two yards next to the street. Because this yard is visible from the street, it is considered a front yard (not a side yard) and has certain conditions attached to it to maintain the appearance along the street.

Required front yard. This yard is determined in most cases by measuring 20 feet toward the house starting at the front property line, including the area between the side property lines.

Required rear yard. This yard is determined by measuring 20 feet toward the street starting at the rear property line, including the area between the side property lines.

Setback. The minimum required distance between any structure and the property line in a front, rear or side yard.

Structure. That which is built or constructed.

RESIDENTIAL ZONING STANDARDS

The following is general information residential zoning districts. Please contact the Planning Division to find out in which zoning district your property is located.

R-0

1 st Story Front Setback- 20 ft	Max. Height - 30 ft 2 stories
2 nd Story Front Setback - 25 ft	Max. Lot Coverage - 40%*
Minimum Side Setback - 4 ft min. for 1 st story, 7 ft. for 2 nd story.	Floor Area Ratio** - 45%
Minimum Combined Side Yard Setbacks - 20% of lot width*** not to be less than 10 ft. for the 1 st story. 2 nd Story shall add 6 ft. to the combined 1 st story setback requirement.	Min. Lot Area - 6,000 sq. ft.
Rear Setback- 20 ft	Max. Density - 1 unit/ 6,000 sq. ft.

* Maximum lot coverage of 45% is allowed for single story homes

** Floor Area Ratios above 45% or where the gross floor area exceeds 3,600 square feet must be reviewed by the Planning Commission

*** Lot width is measured 20 ft. back from the front property line.

R-1

1 st Story Front Setback- 20 ft	Max. Height - 30 ft 2 stories
2 nd Story Front Setback - 25 ft	Max. Lot Coverage - 40%*
Minimum Side Setback - 4 ft min. for 1 st story, 7 ft. for 2 nd story.	Floor Area Ratio - 45%
Minimum Combined Side Yard Setbacks - 20% of lot width*** not to be less than 15 ft. for the 1 st story. 2 nd Story shall add 6 ft. to the combined 1 st story setback requirement.	Min. Lot Area - 8,000 sq. ft.
Rear Setback- 20 ft	Max. Density - 1 unit/ 8,000 sq. ft.

* Maximum lot coverage of 45% is allowed for single story homes

** Floor Area Ratios above 45% or where the gross floor area exceeds 3,600 square feet must be reviewed by the Planning Commission

*** Lot width is measured 20 ft. back from the front property line.

R-1.5

1 st Story Front Setback- 20 ft	Max. Height - 30 ft 2 stories
2 nd Story Front Setback - 25 ft	Max. Lot Coverage - 40%
1 st Story Side Setback - 4 ft min. 12 ft total	Floor Area Ratio - 50%
2 nd Story Side Setback - 7 ft min. 18 ft total	Min. Lot Area - 4,200 sq. ft.
Rear Setback - 20 ft	Max. Density - 1 unit/4,200 sq. ft.

R-1.7/PD

1 st Story Front Setback- 20 ft	Max. Height - 30 ft 2 stories
2 nd Story Front Setback - 20 ft	Max. Lot Coverage - 40%
1 st Story Side Setback - 4 ft min. 12 ft total	Floor Area Ratio - 50%
2 nd Story Side Setback - 7 ft min. 18 ft total	Lot Area-2,600sq.ft. min-4,000sq.ft. max.*
Rear Setback - 20 ft	Max. Density - 1 unit/2,600 sq. ft.

* Minimum lot size for entire development is 2 acres

R-2

1 st Story Front Setback- 20 ft	Max. Height - 30 ft 2 stories
2 nd Story Front Setback - 25 ft	Max. Lot Coverage - 40%*
Minimum Side Setback - 4 ft min. for 1 st story, 7 ft. for 2 nd story.	Floor Area Ratio** - 45%***
Minimum Combined Side Yard Setbacks - 20% of lot width**** not to be less than 10 ft. for the 1 st story. 2 nd Story shall add 6 ft. to the combined 1 st story setback requirement.	Min. Lot Area - 8,000 sq. ft.
Rear Setback- 20 ft	Max. Density - 1 unit / 3,600 sq. ft.

* Maximum lot coverage of 45% is allowed for single story homes.

** Floor Area Ratios above 45% or where the gross floor area exceeds 3,600 square feet must be reviewed by the Planning Commission.

*** Maximum Floor Area Ratio for duplexes or multi-unit properties is 55%.

**** Lot width is measured 20 ft. back from the front property line.

Sample Site Plan Site Illustrating Location of Yards

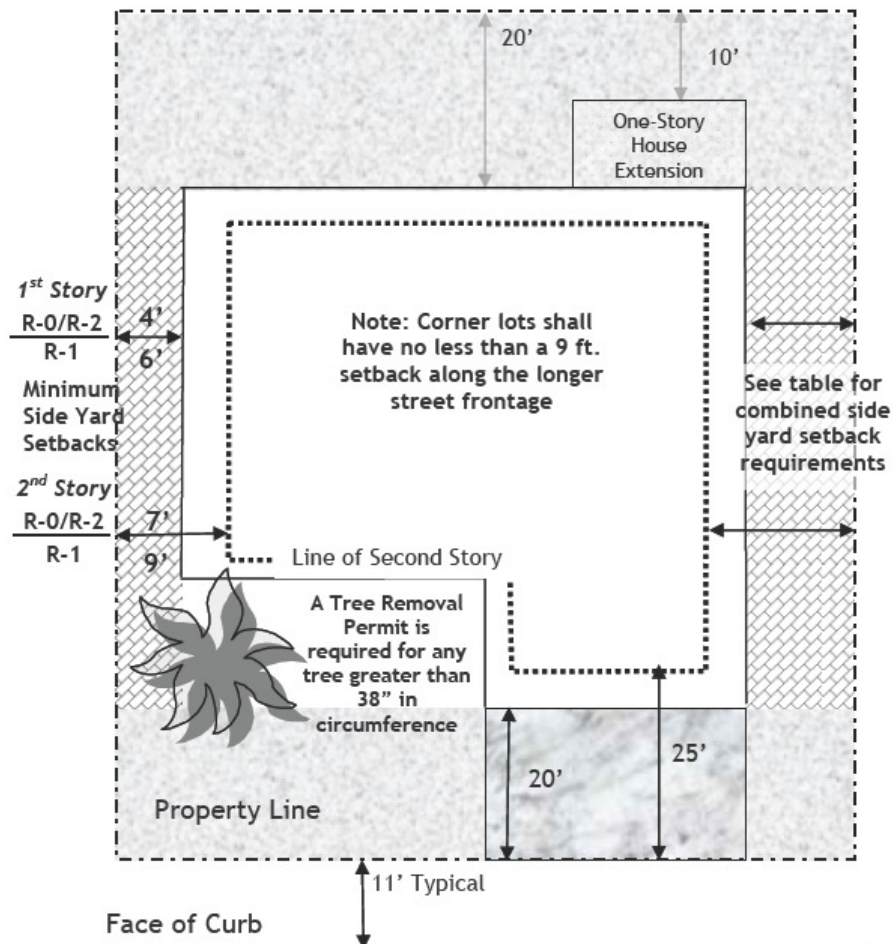

REAR YARD SETBACK EXCEPTION

There is an exception to the rear yard setback for single story building additions or detached structures. A single-story structure may be located up to 10 feet from the rear property line but can only cover 25% of the required rear yard.

VISION TRIANGLES

Keeping vision triangles free of obstructions promotes safety by providing drivers a better view of pedestrian and vehicular traffic while exiting a driveway or approaching a corner. Well-maintained vision triangles provide a better line of sight for drivers, reducing the potential for accidents and possible injuries.

Only natural or structural objects 3.5 feet or less in height may be located within a vision triangle. Open fences may be permitted, provided they meet the requirements described in the Fence section below. Trees are permitted only if the foliage between 3 feet and 8 feet in height is removed.

Driveway Vision Triangle

All lots must maintain a 10 foot driveway vision triangle. The driveway vision triangle is created by measuring 10 feet along the outer edge of a driveway and 10 feet along the back edge of a public sidewalk from the point where the driveway and sidewalk meet. Connecting these two lines with a diagonal line completes the triangle and forms the driveway vision triangle.

Corner Vision Triangle

All corner lots must maintain a 40-foot corner vision triangle. The corner vision triangle is formed by measuring 40 feet along each property line from the corner where the two street sides of the property meet. Connecting these two lines with a diagonal line forms the corner vision triangle.

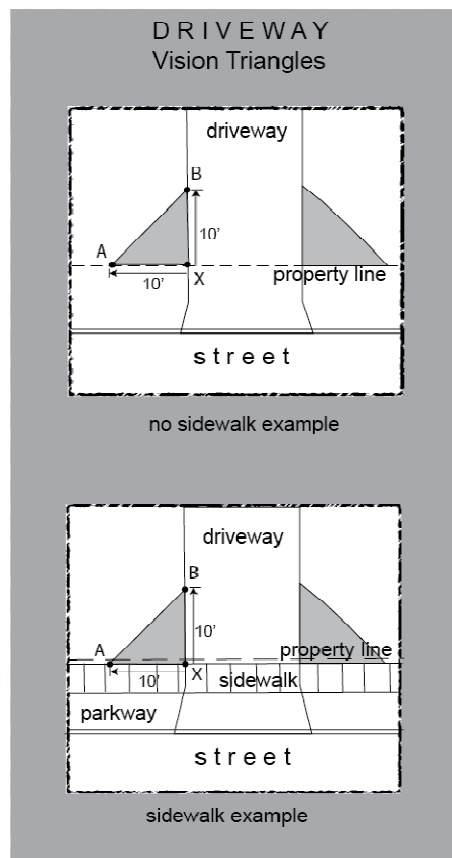
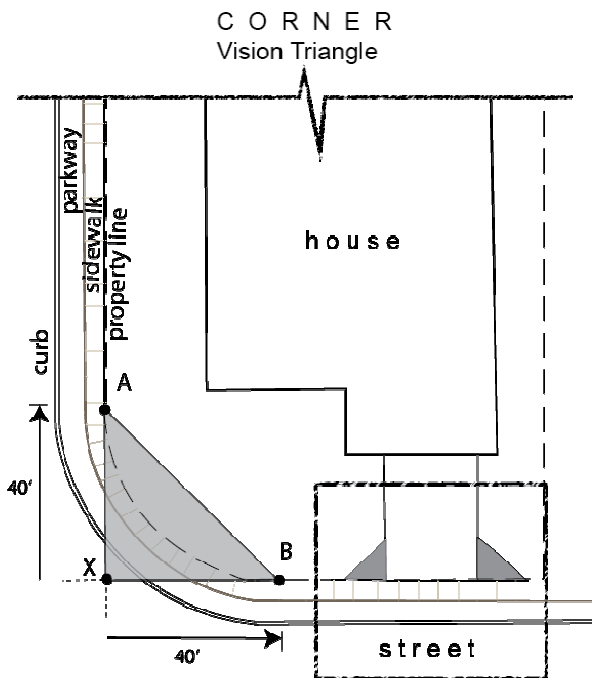

ALLOWABLE HOURS OF CONSTRUCTION

The Sunnyvale Municipal Code Section 16.08.110 limits construction activity to the following hours:

HOURS OF CONSTRUCTION	
Day	Time
Monday through Friday	7:00 a.m. to 6:00 p.m.
Saturday	8:00 a.m. to 5:00 p.m.
Sundays and national holidays	No activity allowed
Extended Hours Allowed for Single Family Detached Housing When the Work is Performed by the Homeowner*	
Monday through Friday	7:00 a.m. to 7:00 p.m.
Saturday	8:00 a.m. to 7:00 p.m.
Sundays and national holidays	9:00 a.m. to 6:00 p.m.

* It is permissible for up to two persons to assist the homeowner as long as they are not hired by the owner to perform the work.

When determined by the Chief Building Official, the following exceptions may be made to the allowable hours of construction:

- No loud environmentally disruptive noises, such as air compressors without mufflers, continuously running motors or generators, loud playing musical instruments, radios, etc. will be allowed where such noises may be a nuisance to adjacent properties.
- Where emergency conditions exist, construction activity may be permitted at any hour or day of the week. Such emergencies shall be completed as rapidly as possible to prevent any disruption to other properties.
- Where additional construction activity will not be a nuisance to surrounding properties, based on location and type of construction, a waiver may be granted to allow hours of construction other than as stated in this section. To request a waiver, contact the Building Safety Division.

PERMITS, PLAN CHECKS, AND FEES

PLANNING PERMITS AND PROCESSING

Residential projects requiring review by the Planning Division generally require, project data, site plan, floor plan, roof plan, site section indicating building height, and architectural elevations for both existing and proposed. Additions including a second story component will also require submittal of a streetscape elevation and Solar Access Analysis. Consult with the Planning Division to determine the type of permit and submittal documents that may be needed for a specific project.

BUILDING PERMITS, PLAN CHECKS, AND INSPECTIONS

A permit is required from the Building Safety Division to erect any building or structure, or addition, alter, repair, move or demolish any building or structure in the City of Sunnyvale. Permits shall be obtained prior to the start of any construction or demolition. Applications for permits may be obtained at the One-Stop Permit Center at City Hall. Many remodeling permits can also be obtained on-line at www.e-onestop.net.

Permits can be issued to a contractor licensed by the State of California to perform such work (roofing, plumbing, electrical, etc.) or the property owner of record.

Permits are valid for 180 days from the date of issuance or the last inspection. A permit can be extended for an additional 180 days at the request of the permit applicant.

WORK EXEMPT FROM REQUIRING A BUILDING PERMIT

Permits are not required for the following:

1. Cosmetic work such as painting, papering, replacing floor coverings, trim work, etc.
2. Detached accessory structures (e.g. utility sheds and play structures) less than 120 square feet of floor area.

Note: Approval from the Planning Division may be required depending on the location of the fence. See the Fence Information page of the Planning Division web site (www.SunnyvalePlanning.com) for more information.

3. Swings and other playground equipment accessory to a detached one- or two-family dwelling.
4. Window replacements where the new window is the same configuration as the previous window and the existing manufactured window frame

remains unchanged. This is commonly referred to as retrofit window replacement.

5. Replacement or repair of 100 square feet or less of an existing roof within any 12-month period.
6. Fences not over 6 feet high.

Note: Approval from the Planning Division may be required depending on the location of the fence. See the Residential Information page of the Planning Division web site (www.SunnyvalePlanning.com) for more information.

7. Retaining walls not over 4 feet high when no other structure is attached to the retaining wall (height is measured from the bottom of the footing to the top of the wall).
8. Window awnings attached to single-family homes and duplexes that are supported by an exterior wall, do not project more than 54 inches from the exterior wall, and do not require additional support.
9. Walks and driveways not over a basement or story below and not part of a disabled accessible route.

Note: Repair or replacement of public sidewalks or driveway curb cuts requires review and approval by the Public Works Department. They can be contacted at (408) 730-7415 for more information.

10. Decks not exceeding 200 square feet in area, not more than 30 inches above grade, are not attached to a building, and do not serve a required exit door.

Note: Review and approval by the Planning Division may be required prior to issuance of a building permit. Contact a planner at the One-Stop Permit Center or (408) 730-7444 for more information.

11. Non-fixed and movable fixtures, cases, racks, counters, and partitions not over 5 feet 9 inches high.

12. Prefabricated swimming pools meeting all of the following criteria:

- Installed on a single family or duplex property,
- Is less than 24 inches deep,
- Is entirely above ground, and
- Does not exceed 5,000 gallons.
- A fence is required to completely surround the pool or spa not less than 5 feet in height with all gates having a self-closing and self-latching device, with no openings in their horizontal dimension greater than 4 inches. (Sunnyvale Municipal Code Section 16.44.030.)

Note: Electrical, mechanical, and plumbing permits may be required for any pool equipment

Note: Review and approval by the Planning Division may be required prior to issuance of a building permit. Contact a planner at the One-Stop Permit Center or (408) 730-7444 for more information.

13. Repair or replacement of existing toilets, faucets, sinks in the same location.
14. Replacement of existing electrical receptacles, switches, and lights (in existing boxes) in the same location and where no change to the outlet or switch type is made.
15. Replacement of over-current devices such as circuit breakers and fuses.
Exception: Replacement of a main disconnect does require a permit.
16. Temporary decorative lighting for a dwelling installed for not more than 90 days (such as seasonal Christmas lights).
17. Portable appliances such as heating appliances, ventilating equipment, cooking equipment, cooling units, and evaporator coolers where no changes to the existing electrical (receptacles, switches, etc.) or plumbing (gas line, water line, etc.) systems are made.
18. Portable equipment and appliances with listed cord and plug connections.

Exemption from the permit requirements shall not be deemed to grant authorization for any work to be done in any manner in violation of the provisions of the building codes or any other laws or ordinances of this jurisdiction.

PLAN CHECK

Plans that are submitted for building plan check and permits shall clearly show all applicable details such as foundation details, framing of floors, walls and roof, size of windows, and details of special features such as fireplaces, chimneys or balconies. Typical plans that may be required include plot/site plan, floor and roof framing plan, floor plan, elevation, and sections.

Express Plan Check

The Express Plan Check process is typically for single story additions and interior remodels. Three complete sets of plans and two sets of other applicable documentation (Title 24 energy calculations, structural calculations, etc.) are required for plan review. Two sets of the plans and any structural calculations shall be signed and stamped by the architect or engineer as necessary.

The building plan check and permit issuance process for most of these types of permits can be completed at the One-Stop Permit Center between the hours of 8:00 a.m. and 12:00 noon.

Regular Plan Check

Second story additions, basement additions, and new construction require five complete sets of plans, three copies of the soils report (for new construction and basement additions), and two sets of other applicable documents (Title 24 energy calculations, structural calculations, etc.) to be submitted for a 21-day plan check. Two sets of the plans, the soils report, and structural calculations shall be wet signed and stamped by the architect or engineer. After the plan review has been completed by all City departments, comments will be returned to the project applicant. After all comments have been addressed, five corrected sets of plans and two sets of other documents are to be re-submitted for a 14-day plan review.

Plans can be submitted between the hours of 8:00 a.m. to 5:00 p.m. at the One-Stop Permit Center.

INSPECTIONS

Building, plumbing, electrical, and mechanical inspections are required to be completed and approved by the building inspector at various stages of construction. No portion of a building or structure (structural framework, electrical, plumbing, or mechanical) shall be covered or concealed without first obtaining inspection and approval of the Building Division.

Required Approvals

The following is a summary of typical inspections and the stage when the inspection should be scheduled. Each project will require the inspections relative to the work that is being done.

MINIMUM REQUIRED INSPECTIONS	
Type of Inspection	Description
Foundation	A foundation inspection shall be scheduled when the trenches are excavated and forms and steel reinforcing bars are in place, but prior to concrete being poured.
Under Floor	An inspection shall be scheduled after all under floor framing, plumbing, electrical, and mechanical is complete and before insulation and the sub-floor are installed.
Roof Nail	A roof nail inspection is required after the roofing deck is installed and before applying any roofing materials.
Exterior Shear Nail	A shear nail inspection is required after the shear walls are installed and before any exterior protection is applied.
Fire Inspection	A residential fire sprinkler system inspection is required for piping, hangers and sprinkler location before the rough framing inspection.
Rough Frame	The rough framing inspection shall be scheduled after the roof and walls are weather tight. All rough framing, rough electrical, rough plumbing, and rough mechanical shall be completed prior to the inspection. Also, if automatic fire sprinklers are installed, a fire inspection shall be completed prior to a rough framing inspection.
Electrical	A rough electrical inspection shall be scheduled after all the electrical wiring is run and before the receptacles are installed. If a rough framing inspection

MINIMUM REQUIRED INSPECTIONS	
Type of Inspection	Description
	is required, the electrical system will be inspected at that time. After all the work is completed, a final inspection shall be scheduled and the electrical fixtures and receptacles will be inspected.
Plumbing	<ul style="list-style-type: none"> • Under floor plumbing: When all under floor work is installed, at under floor inspection. Drainage systems shall be tested and inspected while under 10 foot headwater test and water piping shall be tested under working pressure. • Rough plumbing: A rough plumbing inspection shall be scheduled after all the plumbing systems (drainage, vents, water and gas piping) are completed. If a rough framing inspection is required, the plumbing system will be inspected at that time. Drainage and vent systems shall be tested and inspected while under 10 foot headwater and water piping shall be tested under working pressure. • Main sewer line: The main sewer line and its connection to the public sewer shall be scheduled for a water test inspection. • Gas lines: All gas lines and systems require an inspection before connections are made to the supply lines. If a rough framing inspection is required, the inspection for the gas line shall be inspected along with the rough frame. For the inspection, the installer shall supply equipment to conduct an air pressure test of 3 pounds for 15 minutes to be verified by the Building Inspector.
Mechanical	<ul style="list-style-type: none"> • Under floor inspection: An inspection is required for under floor ducts or vents. If an under floor inspection is required, the mechanical ducts and vents will be inspected at that time. • Rough mechanical: A rough mechanical inspection shall be scheduled after the mechanical system, heat ducts, exhaust and vent ducts are installed. If a rough framing inspection is required, the inspection for the mechanical system shall be inspected along with the rough frame.
Lath and Plaster	An inspection shall be scheduled to inspect the attachment (screwing or nailing) or all firewalls and water-resistant wallboard. An inspection shall also be scheduled to inspect the attachment for all exterior lath.
Insulation	All required insulation shall be inspected after installation and before the material is covered.
Final Fire Inspection	If automatic fire sprinklers were installed, a final inspection from the Fire Inspector shall be scheduled and approved prior to scheduling the final building inspection.
Final Building Inspection	When all work is completed a final inspection shall be scheduled prior to occupancy or use of the area.

Scheduling Building Inspections

Building inspections can be scheduled on-line at www.e-onestop.net. Building inspections can also be scheduled by calling (408) 730-7790 between the hours of 8:00 a.m. and 5:00 p.m. at least one day prior to the requested inspection date. Inspections can be scheduled for either the morning (8:30 a.m. to 1:00 p.m.) or the afternoon (12:00 noon to 4:30 p.m.).

FIRE SPRINKLER PERMITS, PLAN CHECKS, AND INSPECTIONS

Fire Sprinkler System Plan Check

When an automatic fire sprinkler system is required to be installed, the plans submitted for review for the building permit shall include the following notes:

- Automatic fire sprinkler systems shall be installed in accordance with NFPA 13D.
- Fast response fire sprinkler heads shall be installed in habitable spaces.
- The automatic fire sprinkler system shall be installed by a licensed (C-16) contractor, who shall have a City of Sunnyvale Business License and proof of worker's compensation insurance.
- Three complete sets of fire sprinkler plans and calculations (wet signed and stamped by the engineer) shall be submitted for a 21 day plan review at the One Stop Permit Center. Plans and calculations shall be reviewed and permit issued prior to installation.

The plans for fire sprinkler systems shall be designed by a licensed fire sprinkler contractor (C-16). These plans shall be submitted for review and approval independently from the building permit plans.

When automatic fire sprinklers are required, the existing water meter may need to be upgraded by the local water jurisdiction (California Water Service or City of Sunnyvale). The domestic water line from the water meter to the residence may also need to be increased in size to accommodate the fire sprinkler system.

Fire Sprinkler Inspection

The first fire sprinkler inspection shall be completed by the fire inspector prior to scheduling the rough framing inspection with the building inspector. A final fire sprinkler inspections shall be scheduled prior to the final building inspection.

Scheduling Fire Inspections

Fire Inspections can be scheduled by calling (408) 730-7652 between the hours of 8:00 a.m. and 5:00 p.m. Fire inspections are scheduled for a morning or afternoon time frame.

FEES

Fees are associated with planning permit applications and are payable when the application is submitted. Fees are based on the type of application and scope of proposal.

Plan check fees are charged for all permits requiring plan review by one or more divisions. Plan check fees are payable at the time the plans are submitted and the permit fees are payable when the permit is issued. Fees are based on the type of work being performed, the value of the construction, and the square footage of the area of work.

For all new construction and when additional living space of 500 square feet or more is added, school impact fees are required and payable directly to the school districts. Forms are provided by the Building Division and are to be taken by the applicant to the school district offices for payment. Receipt of payment is required prior to issuance of a building permit.

Contact the Building Division at the One-Stop Permit Center or refer to the web site at www.SunnyvaleBuilding.com for the current fee schedule and a fee estimate.

NEW CONSTRUCTION, ADDITIONS, AND INTERIOR REMODEL STANDARDS

ZONING STANDARDS FOR NEW SINGLE FAMILY HOMES AND ADDITIONS TO EXISTING SINGLE FAMILY HOMES

The following is a list of standard requirements related to residential additions or new construction.

DESIGN REVIEW

Any projects resulting in a significant change in the appearance of the exterior, an addition with a second-story component or any residential addition greater than 20% of the existing floor area (including the garage) is subject to the Single-Family Home Design Techniques or Eichler Design Guidelines, as applicable. These techniques are policy statements on neighborhood compatibility, architectural detail and privacy. A copy of these guidelines is available from the Planning Division. Important design considerations include (but are not limited to):

- **Compatibility with the neighborhood.** The appearance of the house must be compatible, both in size and architectural features, with the established character of the neighborhood.
- **Compatibility with the existing house.** Additions should match the existing residence's style and have the same or compatible exterior colors and materials.
- **Window placement and design.** All new second story windows will be reviewed to minimize visual intrusion into adjacent properties. In some cases, frosted glass or privacy windows may be required.

All additions that involve a second story component require noticing of property owners within 200 feet. For additions or homes that are equal to or less than the Floor Area Ratio (FAR) or square footage threshold for each zoning district, the application may be reviewed at the staff level. Projects that exceed the threshold FAR or 3,600 square feet must be reviewed at a public hearing by the Planning Commission.

PARKING

A minimum of two covered spaces and two uncovered spaces are required for a single-family residence. Existing homes with sub-standard parking (less than two covered spaces and two driveway spaces) are required to upgrade the parking to meet the minimum standards whenever an addition is proposed that will result in either four or more bedrooms or total square footage of 1,800 square feet or more (including the garage).

The required minimum area for a two-car garage or carport is 400 square feet. A one-car garage or carport cannot be smaller than 200 square feet. Existing garages smaller

than these dimensions are considered legal non-conforming and may not be reduced in size.

The interior dimension of a two-car garage cannot be reduced to less than a 17 feet width or 18 feet depth; this area os to be clear space for vehicle parking and shall not include any appliances, water heaters, shelves, etc. A one-car garage may not be reduced to less than 8 ½ feet in width or 18 feet in depth. In addition, permanent structures such as stairs and walls may not extend into this required area. Carport dimensions are measured from inside the support columns.

To convert an existing garage or carport to living space, an equivalent number of covered parking spaces must be provided on the property.

All recreational vehicles, trailers, and boats parked or stored within the required front yard (front yard setback) in all residential zones, shall be parked or stored perpendicular to the street.

SOLAR ACCESS

New two-story additions and construction shall not shade more than 10% of the roof area of any adjoining properties. If an adjoining dwelling has existing solar panels, new two-story additions and construction may not shade any portion of the solar panels. A solar access study showing projected shadow patterns on adjoining roofs is required when plans are submitted for design review. The shadow study should be conducted for December 21, the shortest day of the year, between the hours of 9:00 a.m. and 3:00 p.m. See the Planning Division for additional information on the access study requirements.

GREEN BUILDING PROGRAM

On April 24, 2012, the City Council adopted green building standards for new construction, additions, and remodels of buildings. The new requirements were effective for all projects that submit building permits on or after October 1, 2012. The purpose of these standards is to:

- implement sustainable development and construction practices that use natural resources in a manner that does not eliminate, degrade, or diminish their usefulness for future generations,
- enhance the public health and welfare by promoting the environmental and economic health of the city through the design, construction, maintenance, operation, and deconstruction of buildings and other sire development, and
- Incorporate green building practices into all development projects.

The green building program requirements are applicable to residential projects based on the size of the project and scope of work. Certain projects may be required to obtain a minimum point level; other projects may just submit the completed checklist. Verification that required point levels have been achieved will be

determined by City staff. In addition to the BIG checklist, all new construction shall also comply with the 2010 CALGreen.

The standard for residential building is the Build It Green program checklist. Build It Green (BIG) is a non-profit organization whose mission is to promote healthy, energy- and resource-efficient building practices in California. Additional information and the checklists are available on-line at www.builditgreen.org.

The following table shows the minimum point level and verification necessary for various types of projects:

Type of Project	Minimum Standard	Verification/Review Requirement	Voluntary Incentives
All New Construction	GreenPoint Rated Checklist v4.2 or later (which includes CALGreen) with 80 points minimum	Green Point Rater	Achieve 110 points, with Green Point Rater verification, and the project can increase lot coverage by 5%.
Remodels, Alterations, and Additions	CalGreen Mandatory Measures as applicable to the scope of work	City staff	--

WATER EFFICIENT LANDSCAPING AND IRRIGATION

Pursuant to State law, the City has adopted water-efficient landscaping and irrigation regulations which are designed to stretch the limited water supplies, reduce water waste in irrigation, and increase drought resistance.

Construction of a new single family home which includes the installation of 1,000 square feet or more of landscaping requires that the landscape and irrigation plans be prepared by a certified professional unless the project includes less than 2,500 square feet of landscaped area. Certified professional means a licensed landscape architect, licensed landscape contractors, license engineer, certified irrigation designer or any other person authorized by the State to design a landscape or irrigation system.

WATER EFFICIENT PLUMBING FIXTURES

Plumbing fixtures in all new construction or newly installed fixtures shall meet the following water efficiecnny standards:

WATER EFFICIECNY PLUMBING FIXTURES IN NEW KITCHENS/BATHROOMS	
Type of Fixture	Maximum Flow Rate
Water Closet (Toilet)	1.28 gallons/flush
Showerhead	2.0 gallons/minute at 80 psi
Faucet - Bathroom	1.5 gallons/minute at 60 psi
Faucet - Kitchen	1.8 gallons/minute at 60 psi (average)

When a permit is issued for remodel work within a house (i.e. a kitchen or bathroom remodel), the California Civil Code section 1101.4(a) requires that all existing non-compliant plumbing fixtures throughout the house be replaced with water efficiency fixtures. For the purpose of this requirement, the following table defines 'non-complaint' plumbing fixtures:

CALIFORNIA CIVIL CODE 1101.4(A) NON-COMPLIANT PLUMBING FIXTURES	
Type of Fixture	Non-Compliant Fixture
Water Closet (Toilet)	Greater than 1.6 gallons/flush
Showerhead	Greater than 2.5 gallons/minute
Faucet - Bathroom	Greater than 2.2 gallons/minute
Faucet - Kitchen	Greater than 2.2 gallons/minute

If existing plumbing fixtures are non-compliant based on the table above, they are required to be replaced with fixtures that meet the standards for new construction.

RESIDENTIAL AUTOMATIC FIRE SPRINKLERS

All new residential structures shall be provided with an approved automatic fire sprinkler system. When an addition to an existing residential structure exceeds 50% of the existing living area and the addition is a minimum of 500 square feet, an approved fire sprinkler system shall be installed throughout the building.

Fire sprinkler systems shall be designed and installed in accordance with NFPA Standard 13D standard for the *Installation of Sprinkler Systems in One and Two Family Dwellings and Mobile Homes*.

SMOKE AND CARBON MONOXIDE ALARMS

New Construction and Additions

In new construction and additions, required smoke alarms and carbon monoxide alarms shall receive their primary power from the permanent building electrical power system (and shall be on the lighting circuit connected within the same room as the smoke alarm). In dwellings where two or more smoke alarms or carbon monoxide alarms are required they shall be interconnected in such a manner that actuation of one shall cause actuation of all detectors in the dwelling unit.

All new electrical outlets (including smoke alarms, carbon monoxide alarms, receptacles, switches, lighting, etc.) shall be on circuits protected with a combination arc-fault circuit interrupter.

Remodeled Dwelling Units

When a permit is required for any repair, alterations, or addition smoke alarms and carbon monoxide alarms shall be installed in accordance with the following location and maintenance provisions. In existing dwelling units, smoke alarms and carbon monoxide may be battery operated.

SMOKE ALARM AND CARBON MONOXIDE ALARM INSTALLATION AND LOCATION REQUIREMENTS		
Location	Smoke Alarm Required?	Carbon Monoxide Alarm Required?
Outside of each separate sleeping area in the immediate vicinity of bedrooms (i.e. hallway)	Yes	Yes
In each sleeping room	Yes	No
In each story within a dwelling unit, including basements.	Yes	Yes

Smoke Alarm and Carbon Monoxide Alarm Maintenance

The owner shall be responsible for testing and maintaining detectors in hotels, motels, lodging houses, and common stairwells of apartment complexes and other multiple dwelling complexes. The smoke detector shall be operable at the time that the tenant takes possession. The apartment complex tenant shall be responsible for notifying the manager or owner if the tenant becomes aware of an inoperable smoke detector within his or her unit. The owner or authorized agent shall correct any reported deficiencies in the smoke detector and shall not be in violation of this section for a deficient smoke detector when he or she has not received notice of the deficiency.

Smoke Alarm and Carbon Monoxide Alarm Device Location

Smoke alarms shall be installed on the ceiling or wall between 4” and 12” of the ceiling. Carbon monoxide alarms shall be installed on the ceiling or wall above the door header.

Smoke Alarm Batteries and Replacement

All newly installed smoke alarms shall have a 10-year battery. Smoke alarms shall be replaced 10 years from the date of manufacture marked on the unit.

FLOOD ZONES

Properties within the AE or AO flood zones may be subject to special building requirements to limit potential flood damage. All new construction and additions greater than 50% of the existing building floor area within these flood zones must design the finished floor to be above the base flood elevation. A licensed Civil Engineer must provide an Elevation Certificate for the designed project that shows the finished floor elevation is above the base flood elevation prior to issuance a building permit. Prior to the final inspection, a final Elevation Certificate must be provided verifying the built structure is above the base flood elevation.

Addition to existing single family homes that are less than 50% of the existing building floor area are not subject to these requirements.

EXTERIOR IMPROVEMENTS AND ACCESSORY BUILDING/STRUCTURE STANDARDS

ACCESSORY LIVING UNITS

An accessory living unit (also known as a granny flat, in-law quarters or secondary dwelling unit) is a one-bedroom unit that provides independent living accommodations for one or more persons. It can be “attached” (structurally connected to a single-family residence by a minimum 10 foot long common load bearing wall) or “detached” (a separate structure from the main house or not attached to the main residence).

Accessory living units are allowed in R-0, R-1 and R-2 zoning districts and in Downtown Specific Plan (DSP) residential sub-districts and are reviewed through the Miscellaneous Plan Permit (MPP) process. The chart below shows the minimum lot size requirements for accessory living units.

ACCESSORY LIVING UNITS	
Zoning District	Minimum Lot Size
R-0	9,000 square feet
R-1	9,000 square feet
R-2	5,000 square feet
DSP Blocks 8, 9, 10, 11, 12, and 17	5,000 square feet

General Requirements

The following is a list of the requirements for accessory living units.

- The maximum accessory living unit size is 700 square feet.
- The accessory living unit may contain only one bedroom.
- Detached accessory living units may not be located in front of the main residence.
- The primary residence or the accessory living unit must be occupied by at least one property owner.
- At least one parking space must be provided on-site for the accessory living unit in addition to the two covered and two uncovered parking spaces required for the primary dwelling.
- Lots located in the R-2 Zoning District and DSP must provide a total of 1,000 square feet of usable open space.
- The entrance or stairway to an accessory living unit may not be located on any building side facing a street.
- The design of an accessory living unit will be reviewed to ensure it matches the design of the main residence.
- Conversion of covered parking (garage or carport) to an accessory living unit is not allowed unless covered parking can be provided elsewhere on the site and all applicable zoning ordinance requirements can be met.
- Mobile homes and trailers may not be erected as an accessory living unit.

- All other applicable municipal code requirements must be met including, but not limited to: landscaping, irrigation, open space, setbacks, lot coverage, building height and solar access.
- No more than one accessory living unit may be located on any lot.

ACCESSORY STRUCTURES (SHEDS, DECKS, ETC.)

STRUCTURE TYPES

Decks. A roofless, floored structure, with or without a railing.

Detached habitable spaces. An accessory structure which is detached from the main structure and meets the minimum requirements of the building code for human occupancy, such as an office, artist's studio, or game room. If a detached habitable space has cooking and/or eating facilities, it is regulated as an accessory living unit and must comply with development standards as per SMC 19.68.

Detached required parking. An accessory structure which is detached from the main structure and is designed to meet the parking requirements for the property. Garages or carports that are not intended to meet required parking are classified as utility buildings (see below).

Open garden feature. An accessory structure which does not have solid walls, is less than 50% covered, and is primarily intended as a decorative garden feature. Garden features which are 50% covered or more are classified as utility buildings.

Open outdoor equipment. Accessory equipment or structures which are not roofed, do not have solid walls, and are primarily intended for recreation or outdoor cooking. Play houses and other enclosed equipment is classified as utility buildings as defined herein.

Temporary utility tents. These structures are built with lightweight poles, typically plastic or aluminum, that are covered with a tarp or other similar temporary materials. They may be freestanding or embedded into the ground. Temporary utility tents may not be installed for longer than 90 days in a one-year period.

Utility building. An accessory structure which cannot be categorized as any of the above. Utility buildings include detached patio covers, tool sheds, storage sheds, workshops, greenhouses, animal shelters, gazebos, enclosed play houses, and other similar uses.

GENERAL INFORMATION

The area of an accessory structure is calculated by measuring the area of the outside walls. The height of an accessory structure is measured from the highest point of the structure to the finished grade (ground level) within 5 feet of the structure, or within 5 feet of the main building, whichever is less. The size and height of the accessory structure determines where it may be placed on the property.

PLANNING PERMITS

Planning permit requirements for accessory structures 450 square feet or less are listed below. Any accessory structure greater than 450 square feet requires a Use Permit.

Structure Type	Location	
	Front or Reducible Front Yard (including between the building and street)	All Other Areas Including Side and Rear Yards
Deck	No planning permit	No planning permit
Detached Habitable Spaces, Open Outdoor Equipment, and Utility Buildings 8' tall or less	Prohibited	No planning permit
	Greater than 8' - 15'	MPP with Notice
Detached Required Parking	MPP with Notice	MPP with Notice
Open Garden Feature 8' or less in height	No planning permit	No planning permit
	Greater than 8' - 15'	MPP with Notice

SETBACKS

Structure Type	Required Setback		
	Front Yard and Reducible Front Yard	Side	Rear Yard
Decks Less than 18" in height	3'	3'	3'
	18" or greater in height	20'	Zoning Setback*
Detached Habitable Spaces, Open Outdoor Equipment, and Utility Buildings	Up to 8' in height and up to 120 square feet	Prohibited	0
	Up to 8' in height and more than 120 square feet	Prohibited	Zoning Setback*
	Greater than 8' in height up to 15'	Prohibited	Zoning Setback *
Detached Required Parking Garages	20'	Zoning Setback*	10'
Open Garden Feature Up to 8' in height and up to 120 square feet	0'	0'	0'

Structure Type	Required Setback		
	Front Yard and Reducible Front Yard	Side	Rear Yard
Greater than 8' in height up to 15' or greater than 120 square feet	20'	Zoning Setback	10'
Temporary Utility Tents	20'	Zoning Setback	10'

**Additional Setbacks: Utility buildings greater than 120 square feet, detached habitable spaces, and detached required parking structures are also required to meet the setback requirements of the building code. When these structures are located less than 5 feet to the property line, a one-hour fire rated wall is required. No fire rating is required when the structure is located 5 feet or more from the property line. Please contact the Building Division staff at the One-Stop Permit Center for further information.*

ADDITIONAL REQUIREMENTS

The following are additional requirements for sheds:

- If the total floor area of all accessory utility buildings exceeds 450 square feet, the property owner must maintain covered parking on the property for at least 2 cars.
- The combined total of all accessory utility buildings on a lot cannot exceed 800 square feet.

The following are additional requirements for decks:

- Decks that are greater than 30 inches above grade shall have guardrails that are a minimum of 42 inches high and the railing shall have no intermediate spacing of less than 4 inches
- Building permits are not required for decks located a maximum of 30 inches above the finished grade and not more than 200 square feet in area. Decks exceeding either or both of requirements would require a building permit.

PATIO COVER STANDARD CONSTRUCTION DETAIL

Following is a standard detail for construction of a patio cover attached to the house. Other types of construction may be proposed and will be reviewed by the Building Division staff in order to determine compliance with the building code requirements.

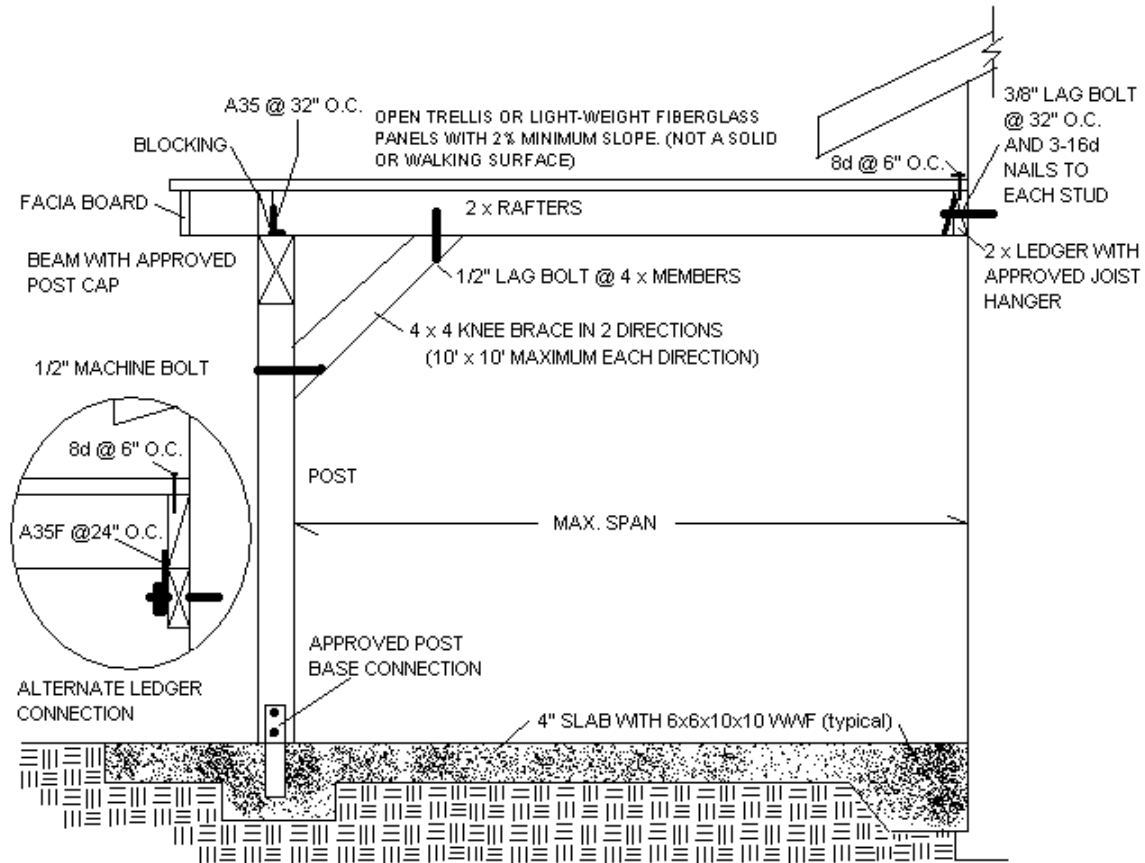

FENCES

While the Planning Division reviews fences for location, material and design standards, the Building Division reviews fences for safe construction. There are different requirements depending on the location and height of the fence. Lattice is included towards total fence height. For planning permit purposes, height is measured from highest adjoining grade, or from the top of nearest curb if in the front or reducible front yard. For building permit purposes, fence height is measured from the lowest adjoining grade.

Retaining walls less than 4 feet (from based on footing to top) do not require a permit. Regardless of height, if a fence is located on top of a retaining wall, a building permit is required.

Open fences is a fence up to 4.5 feet tall with posts spaced at least 8 feet apart. The fence structure above 3.5 feet in height must be no more than 50% solid, similar to the illustration below. Posts or other decorations cannot exceed 12 inches in width or thickness.

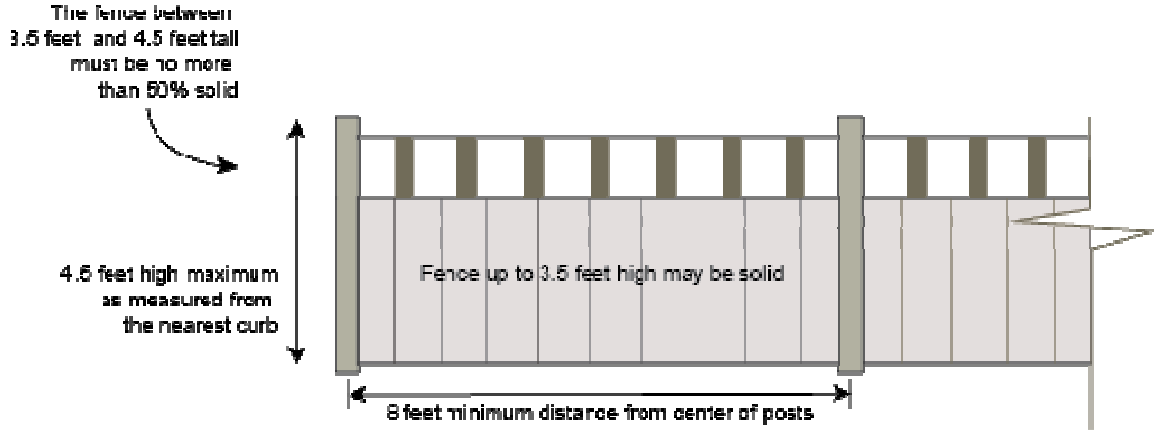

Front Yard Fences

A front yard fence is defined as being between the face of the building and the street. Corner lots have a second front yard (called a reducible front yard) along the longer of the two street frontages. Fences over 4 feet tall in the front yard are discouraged. No fences or other obstructions may be over 3.5 feet high in a driveway or corner vision triangle; except an Open Fence as described above.

If the sidewalk is adjacent to the curb, the fence may only be built to the property line (typically 11 feet back from the curb edge, or 5.5 feet from the sidewalk edge). If there is a landscape strip between the sidewalk and the curb, fences may be built to the edge of the sidewalk.

FENCES WITHIN FRONT YARD SETBACKS	
Fence Height*	Review Process
Up to 4 feet	No permit required. Fence may not exceed 3 feet in any vision triangles.
4+ to 6 feet	MPP
Over 6 feet	Use Permit and building permit required.

* For Planning permits, front yard fence height is measured from the top of the nearest curb.

FENCES ON CORNER LOTS IN REQUIRED REDUCIBLE FRONT YARDS	
Fence Height*	Review Process
Up to 6 feet	No permit required
6+ to 8 feet	No planning permit is required if the fence is set back 2 feet from the property line for every foot in height above 6 ft. (i.e. a 7 feet fence must be set back 2 feet) A MPP is required if the fence does not meet this setback requirement. In all cases a building permit is required.
Over 8 feet	Use Permit and building permit required.

* For Planning permits, front yard fence height is measured from the top of the nearest curb.

Side or Rear Yard Requirements

Side and rear yard fences may be located on the property line or slightly adjacent. Either location requires the following review process.

FENCES LOCATED IN THE SIDE OR REAR YARDS	
Fence Height**	Review Process
Up to 8 feet	No planning permit required. Building permit required for fences above 6 feet
Over 8 feet	Use Permit and building permit required.

** For Planning Permits, side and rear yard fence height is measured from highest adjoining grade.

FENCE STANDARD CONSTRUCTION DETAIL

Following is a standard detail for construction of a patio cover attached to the house. Other types of construction may be proposed and will be reviewed by the Building Division staff in order to determine compliance with the building code requirements.

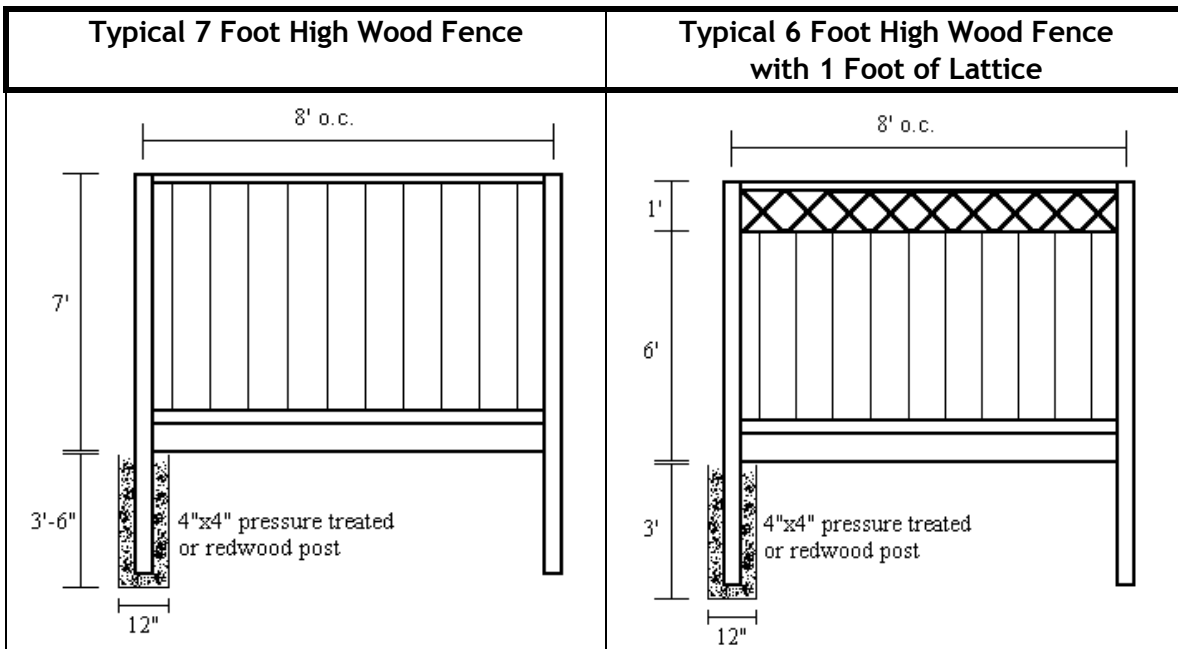

POOLS, PONDS, AND OUTDOOR SPAS

The following are general requirements for receptacles, lighting fixtures, lighting outlets, switching devices, and ceiling fans located around a pool area.

Receptacles

A receptacle that provides power to a water-pump motor or other loads directly related to the circulation and sanitation system, a permanently installed pool or fountain; shall be permitted between 5 feet and 10 feet from the inside walls of the pool or fountain. The receptacle shall be single and of the locking and ground types and shall be protected by a ground -fault circuit interrupter (GFCI).

Where a permanently installed pool/spa is installed at a dwelling at least one 15 or 20 ampere receptacle on a general-purpose branch circuit shall be located a minimum of 10 feet from and not more than 20 feet from the inside wall of the pool. This receptacle shall be located not more than 6 feet 6 inches above the floor, platform or grade level serving the pool or spa/hot tub.

All 125-volt receptacles located within 20 feet of the inside wall of a pool or spa/hot tub shall be protected by a ground -fault circuit interrupter (GFCI).

Lighting Fixtures, Lighting Outlets, and Ceiling Suspended Fans

In indoor pool areas, lighting fixtures, light outlets, and ceiling-suspending fans shall not be installed over the pool or spa. Following is a listing of requirements for these fixtures when installed around a pool:

LIGHTING FIXTURE/OUTLET AND CEILING SUSPENDE FANS LOCATED NEAR POOLS	
Location - Measured Horizontally from the Pool	Fixture Requirements
Up to 5 feet	No fixtures allowed less than 12 feet above the maximum water level.
Between 5 feet and 10 feet	When located less than 5 feet in height shall be GFCI protected.

Disconnecting

A disconnecting means shall be provided and accessible, located within sight from all pools, spas, and hot tub equipment, and shall be located at least 5 feet from the inside walls of the pool, spa, or hot tub.

Bonding, Wiring, and Electrical

The following parts shall be bonded together by a solid copper conductor not smaller than #8 AWG:

- All metallic parts of the pool structure, including the reinforced steel
- The forming shell
- All metallic fittings within or attached to the pool structure
- Metal parts of electrical equipment associated with the pool water circulating system, including pump motors
- Metallic conduit and metallic piping within 5 feet of the inside walls of the pool by a permanent barrier
- All fixed metallic parts that are within 5 feet of the inside walls of the swimming pool and that are not separated from the pool area by a permanent barrier

Wiring shall not be placed over a pool or within 10 feet horizontally from the inside of the walls of the pool, nor over a diving structure, observation stand, tower or platform. Underground wiring within 5 feet of the pool edge shall meet the following burial depth requirements:

MINIMUM BURIAL DEPTHS	
Wiring Method	Minimum Burial
Rigid metal conduit	6 inches
Intermediate metal conduit	6 inches
Nonmetallic raceways listed for direct burial without concrete encasement	18 inches
Other approved raceways	18 inches

If the existing main electrical service is 100 amps or less, provide load calculations for all existing loads and the new pool to justify the service is adequate.

Junction boxes shall be a minimum vertical distance of 8 inches above the water or 4 inches above the deck, whichever provides the greater elevation. Junction boxes shall be a minimum horizontal distance of 4 feet from the inside wall of the pool (unless separated by a solid wall, fence, or other permanent barrier).

At least one GFCI receptacle shall be located at least 10 feet and not more than 20 feet from the inside wall of the pool.

Protective Fencing and Glazing

All private swimming pools shall be equipped with at least one of the following safety features:

1. The pool shall be isolated from access to the home by an enclosure that meets all of the following:
 - Gates shall open away from the swimming pool with opening devices placed a minimum of 60 inches above the ground. Gates shall be self-closing and self-latching;
 - Enclosure shall be a minimum of 60 inches high;
 - The clearance from the ground to the bottom of the enclosure shall be 2 inches maximum;
 - Gaps or voids in the enclosure are spaced so that a 4 inch sphere cannot pass through; and
 - The enclosure shall not have any protrusions, cavities, or other characteristics that would serve as hand/foot-holds.
2. The pool shall incorporate removable mesh pool fencing that meets ASTM Specifications F 2286 standards in conjunction with a gate that is self-closing and self-latching and can accommodate a key lockable device.
3. The pool shall be equipped with an approved safety pool cover that meets all requirements of the ASTM Specifications F 1346.
4. The residence shall be equipped with exit alarms on all doors providing direct access to the pool.

5. All doors providing direct access from the home to the swimming pool shall be equipped with a self-closing, self-latching device with a release mechanism placed no lower than 54" above the floor.
6. Swimming pool alarms that, when placed in pools, will sound upon detection of accidental or unauthorized entrance into the water. These pool alarms shall meet and be independently certified to the ASTM Standard F 2208. For purposes of this article, "swimming pool alarms" shall not include swimming protection alarm devices designed for individual use, such as an alarm attached to a child that sounds when the child exceeds a certain distance or becomes submerged in water.

Glass within 5 feet horizontally from the pool edge and within 5 feet vertically of the walking surface shall be safety glazing.

Anti-Suction Outlets

All new and remodeled pools and spas shall have all suction outlets shall be provided with an anti-entrapment cover meeting current standards of the American Society for Testing and Materials (ASTM) or the American Society of Mechanical Engineers (ASME).

Setbacks For Pools, Spas, and Related Equipment

Pools and spas have different required setbacks depending upon whether the installation is above or below ground. The height is measured from grade.

Any pool/spa than extends 18 inches or more above the ground has a rear yard setback of 10 feet. The pool/spa must meet the side yards setbacks required for the zoning district.

A pool or spa less than 18 inches in height above the finished grade does not have any specific Planning Division setbacks. However, it cannot be located closer than 5 feet to a building or property line unless it is designed by an engineer to meet certain criteria.

Pool/spa equipment cannot be located closer than 3 feet to any other structure or property line, measured at the closest point. Noise generated by pool/spa equipment, regardless of its location, cannot exceed 65 decibels during the day, or 50 decibels at night as measured from any property line.

PHOTOVOLTAIC PANELS

All photovoltaic panels shall be installed in accordance with the manufacturer's instructions and the building code requirements. All equipment shall be UL listed for the installation and purpose. Photovoltaic systems shall be installed by qualified persons. This is defined as a person who has skills and knowledge related to the construction and operation of the electrical equipment and installations and has received safety training to recognize and avoid the hazards involved.

The majority of roof top photovoltaic panels are able to be supported by the existing roof framing. However, if the weight of the panels is excessive the existing roof structure and lateral design may need to be reinforced to accommodate the added load.

Panels shall be located to provide the following roof-top clearances (except for roofs with a slope of 2:12 or less):

- Hip roofs shall have a three foot wide pathway from eave to the ridge.
- Single-ridge roofs shall have two accesses that are each three foot wide from eave to the ridge.
- Hips and valleys with panels on both sides shall have an 18 inch clearance from each side to the hip and valley. When panels are located on only one side of the hip or valley, they can be placed directly adjacent to the hip or valley.
- Ridge - Panels/modules to be located no higher than three feet below ridge.

ANTENNAS AND SATELLITE DISHES

Antennas

Standard television reception antennas are exempt from any planning requirements provided that the:

- antenna has a diameter of 39 inches or less
- antenna is mounted on a mast less than 12 feet high
- antenna is not located in a historic district or on a historic building
- antennas location, to the extent feasible, is not readily visible from the public right-of-way
- amateur radio antennas do not exceed the maximum building height limits of the zoning district

Satellite Dishes

Receive-only parabolic dishes or antennas less than 39 inches in diameter are exempt from any planning requirements. These types of dishes over 39 inches in diameter require review and approval of a Miscellaneous Plan Permit prior to installation.

TREE REMOVAL

A Tree Removal Permit is required to remove any “protected tree” on private property. A protected tree is any single trunk tree 38 inches or greater in circumference or any multi-trunk tree which has at least one trunk 38 inches or greater in circumference or where the measurements of the multi-trunks added together equal at least 113 inches. The circumference of the tree is measured 4.5 feet above the ground. Removal or damage of any protected tree without an approved permit is unlawful and can result in fines or penalties.

Removal of street trees, those in the parkway strip or public right-of-way, requires a different permit from the Trees and Landscape Division of the Department of Public Works, which can be reached at (408) 730-7505.

Permit Review Criteria

One or more of the following criteria must be met before a Tree Removal Permit can be granted:

1. The tree is diseased or badly damaged.
2. The tree represents a potential hazard to people, structures or other trees.
3. The tree is in sound condition but restricts the owners' ability to enjoy the reasonable use or economic potential of the property. It may also unreasonably restrict an adjoining property owner's use or economic potential of the adjoining property. If this applies, the factors below will be used to make a decision regarding removal.
 - The need to allow construction of improvements and to allow economic or reasonable enjoyment of property
 - The approximate age of the tree relative to its average life span
 - The limited useful landscape value due to its inappropriate species, size and location relative to the existing structures on the property
 - The topography of the land and the effect of the requested action on water retention and diversion or increased flow of surface water The potential effect of removal on soil erosion and stability where the tree is located
 - Current and future visual screening potential
 - Overcrowding of trees unreasonably restricting the use of the land
 - Any other information the Director of Community Development finds pertinent to the application.

Tree Replacement

If a Tree Removal Permit approved, a replacement 24-inch box sized tree is typically required to be planted. A larger or smaller replacement tree may be approved upon review of specific cases. The species and location do not need to be the same as what was previously removed. This replanting shall occur within a specified time period, typically 90 days from the time the tree is removed. If you choose not to replace the tree, you must pay an in-lieu fee, which will go towards planting more trees on public properties in the City.

CONSTRUCTION STANDARDS AND DETAILS

The following construction standards and details are based on the current building codes. This information is intended to provide general information and requirements for conventional construction of single family homes. This does not necessarily contain all requirements for all types of construction.

FRAMING AND FOUNDATION CONSTRUCTION

QUALITY OF LUMBER

Joists, rafters, beams and other structural members must be equal to or better than No. 2 Douglas Fir and shall be identified with a grade marking by an approved grading agency.

NAILING SCHEDULE

Following is a framing and foundation nailing schedule:

FASTENER SCHEDULE FOR STRUCTURAL MEMBERS			
Item	Description of Building Elements/Materials	Description of Fastener	Spacing of Fasteners
Roof			
1	Blocking between joists or rafters to top plate, toe nail	3-8 (2 ½" x 0.113")	---
2	Ceiling joists to plate, toe nail	3-8 (2 ½" x 0.113")	---
3	Ceiling joists not attached to parallel rafter, laps over partitions, face nail	3-10d	---
4	Collar tie rafter, face nail or 1 ¼" x 20 gage ridge strap	3-10d (3" x 0.128")	---
5	Rafter to plate, toe nail	2-16d (3 ½" x 0.135")	---
6	Roof rafters to ridge, valley or hip rafters: Toe nail Face nail	4-16d (3 ½" x 0.135") 3-16d (3 ½" x 0.135")	--- ---
Wall			
7	Built-up corner studs	10d (3" x 0.128")	24" o.c.
8	Built-up header, two pieces with ½" spacer	16d (3 ½" x 0.135")	16" o.c. along each edge
9	Continued header, two pieces	16d (3 ½" x 0.135")	16" o.c. along each edge
10	Continuous header to stud, toe nail	4-8d (2 ½" x 0.113")	---
11	Double studs, face nail	10d (3: x 0.128")	24" o.c.
12	Double top plates, face nail	10d (3: x 0.128")	24" o.c.

FASTENER SCHEDULE FOR STRUCTURAL MEMBERS			
Item	Description of Building Elements/Materials	Description of Fastener	Spacing of Fasteners
13	Double top plates, minimum 48-inch offset of end joints, face nail in lapped area	8-16d (3 1/2" x 0.135")	---
14	Sole plate to joist or blocking, face nail	16d (3 1/2" x 0.135")	16" o.c.
15	Sole plate to joist or blocking at braced wall panels	3-16d (3 1/2" x 0.135")	16" o.c.
16	Stud to sole plate, toe nail	3-8d (2 1/2" x 0.113") or 2-16d (3 1/2" x 0.135")	---
17	Top or sole plate to stud, end nail	2-16d (3 1/2" x 0.135")	---
18	Top plates, laps at corners and intersections, face nail	2-10d (3" x 0.128")	---
19	1" brace to each stud and plate, face nail	2-8d (2 1/2" x 0.113") 2 staples 1 3/4"	---
20	1" x 6" sheathing to each bearing, face nail	2-8d (2 1/2" x 0.113") 2 staples 1 3/4"	---
21	1" x 8" sheathing to each bearing, face nail	2-8d (2 1/2" x 0.113") 3 staples 1 3/4"	---
22	Wider than 1" x 8" sheathing to each bearing, face nail	3-8d (2 1/2" x 0.113") 4 staples 1 3/4"	---
Floor			
23	Joist to sill or girder, toe nail	3-8d (2 1/2" x 0.113")	---
24	1" x 6" sub floor or less to each joist, face nail	2-8d (2 1/2" x 0.113") 2 staples 1 3/4"	---
25	2" sub floor to joist or girder, blind and face nail	2-16d (3 1/2" x 0.135")	---
26	Rim joist to top plate, toe nail (roof applications also)	8d (2 1/2" x 0.113")	6" o.c.
27	2" planks (plank & beam - floor & roof)	2-16d (3 1/2" x 0.135")	At each bearing
28	Built-up girders and beams, 2-inch lumber layers	10d (3" x 0.128")	Nail each layer as follows: 32" o.c. at top and bottom and staggered. Two nails at ends and at each splice.
29	Ledger strip supporting joists or rafters	3-16d (3 1/2" x 0.135")	At each joist or rafter
Wood structural panels, sub floor, roof and interior wall sheathing to framing and particleboard wall sheathing to framing			
30	3/8" - 1/2"	6d common (2" x 0.113")nail (sub floor wall) 8d common (2 1/2" x 0.131")nail (roof)	Edge: 6 Intermediate: 12
31	5/16" - 1/2"	6d common (2" x 0.113")nail (sub floor wall) 8d common (2 1/2" x 0.131")nail (roof)	Edge: 6 Intermediate: 12

FASTENER SCHEDULE FOR STRUCTURAL MEMBERS			
Item	Description of Building Elements/Materials	Description of Fastener	Spacing of Fasteners
32	19/32" - 1"	8d common nail (2 1/2" x 0.131")	Edge: 6 Intermediate: 12
33	1 1/8" - 1 1/4"	10d common (3" x 0.148") nail or 8d (2 1/2" x 0.131") deformed nail	Edge: 6 Intermediate: 12
Other wall sheathing			
34	1/2" structural cellulosic fiberboard sheathing	1/2" galvanized roofing nail, 7/16" crown or 1" crown staple 16 ga., 1 1/4" long	Edge: 3 Intermediate: 6
35	25/32" structural. cellulosic fiberboard sheathing	1 3/4" galvanized roofing nail, 7/16" crown or 1" crown staple 16 ga., 1 1/2" long	Edge: 3 Intermediate: 6
36	1/2" gypsum sheathing	1 1/2" galv. roofing nail; staple galvanized, 1 1/2" long; 1 1/4" screws, Type W or S	Edge: 7 Intermediate: 7
37	5/8" gypsum sheathing	1 3/4" galv. roofing nail; staple galvanized, 1 5/8" long; 1 5/8" screws, Type W or S	Edge: 7 Intermediate: 7
Wood structural panels, combination sub floor underlayment to framing			
38	3/4" and less	6d deformed (2" x 0.120") nail or 8d common (2 1/2" x 0.131") nail	Edge: 6 Intermediate: 12
39	7/8" - 1"	8d common (2 1/2" x 0.131") nail or 8d deformed (2 1/2" x 0.120") nail	Edge: 6 Intermediate: 12
40	1 1/8" - 1 1/4"	10d common (3" x 0.148") nail or 8d deformed (2 1/2" x 0.120") nail	Edge: 6 Intermediate: 12

FOUNDATIONS

Footings and foundations shall be constructed of masonry, concrete or treated wood and shall extend below the frost line. Footings shall have a minimum depth as indicated in the table below, unless another depth is recommended by a foundation investigation.

FOUNDATIONS FOR STUD BEARING WALLS (MINIMUM REQUIREMENTS)				
Number of Floors Supported By the Foundation	Thickness of Concrete Foundation Wall (inches)	Width of Footing (inches)	Thickness of Footing (inches)	Depth Below Undisturbed Earth (inches)
1	6	12	6	12
2	8	15	7	18
3	10	23	8	24

Foundation Plates or Sills

Wood plates or sills shall be bolted to the foundation or foundation wall. Steel bolts with a minimum nominal diameter of 1/2 inch shall be used. Bolts shall be embedded at least 7 inches into the concrete or masonry and shall be spaced not more than 6 feet apart (4 feet maximum if the building is over two stories). There shall be a minimum of two bolts per mudsill with one bolt located not more than 12 inches or less than seven bolt diameters from each end of the sill. Plate washers a minimum of 3 inches

by 3 inches by ¼ inch thick shall be used on each bolt. Foundation plates and sills shall be foundation grade redwood or other pressure treated wood with an approved preservative.

Foundation Details

Typical foundation details for raised floors and slab construction are located in the Appendix.

Plates, Sills And Sleepers

All foundation plates or sills and sleepers on concrete or masonry, which is in direct contact with earth, shall be of naturally durable or preservative-treated wood. The minimum size must be 2 inches nominal in thickness by the full width of studs. Fasteners for preservative-treated wood shall be hot-dipped zinc-coated galvanized steel, stainless steel, silicon bronze, or copper.

Under Floor Access

Accessible under floor areas shall be provided with a minimum 18 inches by 24 inches opening when through the floor, or 16 inches by 24 inches when through a perimeter wall. All openings shall be unobstructed by pipes, ducts, or similar construction.

Under Floor Clearance

All wood floors shall be provided with an 18 inch clearance to earth from underside of floor joists (or bottom of wood structural floors without joists). Clearance from girders to earth shall be 12 inches minimum.

Under Floor Ventilation

Under floor areas shall be ventilated by openings in the exterior foundation wall, with a net area of not less than 1 square foot for each 150 square feet of under floor area. One ventilation opening shall be located within 3 feet of each corner of the building. The required area of such openings shall be approximately equally distributed along the length of at least two opposite sides. They shall be covered with corrosion-resistant wire mesh with mesh openings of 1/8 inch.

Mechanical under floor ventilation may be provided in-lieu of natural ventilation when the crawl space perimeter walls are insulated in accordance with the minimum R value of insulation as required by the energy report for the project (typically not less than R19). Mechanical ventilation shall be continuously running and provide ventilation at a rate of 1.0 cubic foot per minute for each 50 square feet of under floor area, including any air pathways (i.e. duct or transfer grille). The under floor area insulation shall be permanently fastened to the wall and extend downward from the floor to the finished grade level and vertically or horizontally for at least an additional 24 inches.

FLOOR CONSTRUCTION

Girders for single-story construction or girders supporting loads from a single floor shall not be less than 4 inches by 6 inches for spans 6 feet or less, provided that girders are spaced not more than 8 feet on center. The end of beams and girders

supported on masonry or concrete shall not have less than 3 inches of bearing. The ends of wood girders entering exterior masonry or concrete walls shall be provided with ½ -inch air space on top, sides and end unless naturally durable or preservative - treated wood is used.

WALL FRAMING

Studs supporting floors and bearing walls shall be a minimum 2 x 4 and spaced not more than 16 inches on center. Stud spacing at 24 inches on center may be used for wall supporting the ceiling and roof only.

When using 24 inches spacing the wall material will need to be verified that it is approved for installation with supports at 24 inches on center. Studs that are 2x may be used at 16 inches or 24 inches on center for non-bearing partitions only. Top plates shall be doubled and splices shall be offset a minimum of 48 inches and nailed with eight 16d nails (6 inches on center) within 48 inches of laps. Where top or bottom plates are cut or partially cut for passage of pipes, a 16-gauge metal tie 1½ inches wide shall be fastened to each side of plate with eight 16d nails on each side.

All bearing walls and partitions shall have double top plates, with joints in top plates staggered not less than 4 feet. Top plates shall be lapped at corners and intersections.

In exterior walls and bearing partitions, any wood stud may be cut or notched to a depth not exceeding 25 percent of its width. Cutting or notching to a depth not greater than 40 percent of the stud width is permitted in non-bearing partitions supporting no loads. A hole not greater than 40 percent of the stud width may be bored in any wood stud. Bored holes not greater than 60 percent of the width of the stud are permitted in non-bearing partitions or in any wall where each bored stud is doubled provided not more than two such successive doubled studs are bored. In no case shall the edge of the bored hole be nearer than 5/8 inch to the edge of the stud. Bored holes shall not be located at the same section of a cut or notch.

All exterior walls and main interior partitions shall be effectively braced. All openings in bearing walls shall be provided with headers to support loads. Walls shall be effectively fire blocked with 2x material at floor, ceiling, and stairways. Fire stopping shall be provided at a maximum of 10 foot intervals

All walls and partitions shall be effectively fire blocked with 2 inch lumber or ½ inch gypsum board the full width of the studs at the floor, ceiling and between the floor and ceiling at intervals not to exceed 10 feet vertically or horizontally.

All wood frame walls covered with plaster, tile, or similar materials which are subject to water splash shall be protected with 15 pound asphalt-saturated felt.

All wood columns and posts shall be framed to true end bearing and shall extend down to supports of such design as to hold the column or post securely in position and to protect its base from deterioration.

Typical details for wall framing and framing around opening are located in the Appendix.

ROOFS

Rafters and Joists Design

The following rafters and joist table may be used to determine conventional frame member size requirements based on general design requirements. The allowable spans for horizontal load bearing members shall be taken as the clear horizontal distance between supports.

RAFTER AND JOIST TABLE #2 OR BETTER DOUGLAS FIR MAXIMUM ALLOWABLE SPANS (partition loads not included)						
Size	Spacing (inches o.c.)	Floor Joist ¹	Ceiling Joist ²	Rafters ³ (light weight roofs, i.e. comp.)	Rafters ⁴ (heavy roof, i.e. tile)	Rafters ⁵ - Ceiling Attached
2 X4	12	--	12' 5"	9' 10"	9' 10"	--
2 X4	16	--	11' 3"	8' 11"	8' 6"	--
2 X4	24	--	9' 10"	7' 10"	6' 11"	--
2 X 6	12	10' 9"	19' 6"	15' 4"	14' 4"	14' 4"
2 X 6	16	9' 9"	17' 8"	13' 9"	12' 5"	12' 5"
2 X 6	24	8' 1"	14' 9"	11' 7"	10' 2"	10' 2"
2 X 8	12	14' 2"	25' 8"	20' 3"	18' 2"	18' 2"
2 X 8	16	12' 7"	22' 10"	18' 1"	15' 9"	15' 9"
2 X 8	24	10' 2"	18' 6"	14' 10"	12' 10"	12' 10"
2 X 10	12	17' 8"	26' 0"	24' 10"	22' 3"	22' 3"
2 X 10	16	15' 3"	25' 5"	21' 6"	19' 3"	19' 3"
2 X 10	24	12' 3"	22' 10"	17' 7"	15' 8"	15' 8"
2 X 12	12	20' 6"	--	25' 9"	25' 9"	25' 9"
2 X 12	16	17' 7"	--	25' 2"	22' 4"	22' 4"
2 X 12	24	14' 4"	--	20' 6"	18' 3"	18' 3"

¹ Live load=40 psf, dead load=10 psf, deflection=L/360, residential living areas

² Live load=10 psf, dead load=5 psf, deflection=L/240, uninhabitable attics without storage

³ Roof live load=20 psf, dead load=10 psf, deflection=L/240f, ceiling not attached to rafters

⁴ Roof live load=20 psf, dead load=20 psf, deflection=L/240, ceiling not attached to rafters

⁵ Roof live load=20 psf, dead load=20 psf, deflection=L/240, ceiling attached to rafters

All joists shall have a minimum bearing of 1½ inches when supported on wood or metal and 3 inches bearing on masonry or concrete walls except when supported on a ribbon board and nailed securely to the adjoining stud.

Ceiling joists and rafters shall be nailed to each other. Where ceiling joists are not parallel to rafters, an equivalent rafter tie shall be installed in a manner to provide a continuous tie across the building. Rafter ties shall be minimum 2 X 4 members.

All floor joists under and parallel to bearing partitions shall be doubled, spiked together or may be separated by solid blocking not more than 4 feet on center to permit the passage of pipes.

Solid blocking not less than 2 inches thick and the full depth of the joists shall be provided over each support and at the ends of each joist.

Opening in the roof and ceiling shall be framed with header and trimmer joists. Header joists over 6 feet long and tail joists over 12 feet long shall be hung in approved joist hangers. When the header joists span more than 4 feet, the trimmer joist and header joist shall be doubled.

Notches on the end of joists shall not exceed 1/4 the joist depth. Holes bored in joists shall not be within 2 inches of the top or bottom of the joist and the diameter of any such holes shall not exceed 1/3 the depth of joist. Notches in the top or bottom of joists shall not exceed 1/6 the depth and shall not be located in the middle third of the span.

Girders, beams, or trusses shall not be notched, bored or otherwise reduced in size.

All joists and beams shall be kept not less than 2 inches from all flues and chimneys; except that reduction to 1 inch is permitted for fireplaces and chimneys in exterior walls, and at least 4 inches from back of fireplaces. All spaces between chimneys and wood framing at floors, ceilings and roof shall be fire stopped with noncombustible material.

Attic Access

Attic areas with a height greater than 30 inches shall be accessible. The attic access shall not be less than 20 inches by 30 inches. A minimum of 30 inches clear headroom shall be provided at or above the access opening.

Attic Ventilation

Enclosed attics and enclosed rafter spaces formed where ceilings are applied directly to the underside of roof framing members shall be cross ventilated for each separate space. Ventilation shall be provided at a rate of 1 square foot for each 150 square feet of attic area. Ventilation may be reduced to 1 square foot for each 300 square feet of attic area when 40% to 50% of the required ventilation area is provided by ventilators located no more than 3 feet below the ridge or highest attic point and the remaining ventilation is provided by eaves or cornice vents.

A minimum of 1 inch of air space shall be provided between the insulation and the roof sheathing.

Ventilation openings shall be protected against rain. Openings shall also be covered with corrosion-resistant wire cloth screening, or similar material, with openings between 1/16 inch and 1/4 inch.

ROOF CONSTRUCTION

Roof framing and trusses shall be properly braced to prevent rotation and provide lateral stability. Trusses shall not be connected to interior walls unless the trusses and the interior walls are properly designed for the interior support.

The allowable span of roof rafters shall be measured along the horizontal projection of the rafter from plate to ridge except that where rafters are braced with purlins and struts to bearing partitions, the span may be reduced.

Purlins shall be continuous and shall be supported by a minimum of 2 X 4 brace spaced at 4 feet on center. Purlin braces (kickers) shall be installed vertical or at an angle up to 45 degrees measured from the vertical. All purlin braces (kickers) shall be connected to the top plate of a bearing wall and the unbraced length of braces shall not exceed 8 feet. In no case shall a purlin be less in size than the rafters it supports.

A ridge board shall be installed at all ridges at least 1 inch thick not less in depth than the end cut of the rafter. Where the slope of the roof is less than 3:12 the ridge member shall be designated as a load-bearing member.

All valley and hip rafters shall be not less than 2 inches thick and not less in depth than the end cut of the rafter.

Minimum 1 X 4 collar ties shall be installed in the upper third of the attic spaces not more than 4 feet on center.

The use of roof trusses shall require Building Safety Division approval of engineering design, details, and calculations. Trusses shall not be cut or altered without review and approval from the Building Safety Division.

ROOF COVERING

Roof decks shall be covered with an approved roof covering secured to the building or structure. Roof covering shall be designed, installed, and maintained in accordance with the building code and the manufacturer's instructions to ensure the roof covering protects the building or structure.

The Sunnyvale Municipal Code requires that all new roof material be a minimum of a Class B fire rating.

Replacement roofs on residential structures may require review and approval from the Planning Division prior to issuance of a building permit. Contact the Planning Division for specific information on roofing requirements.

Roof drains shall be provided and shall be direct water away from the building and toward a permeable surface. Roof drains shall not connect to any sanitary sewer system.

The following are general requirements for the installation of common roofing materials. For further information consult the 2013 California Residential Code. All roof material shall be installed in accordance with the following requirements and the manufacturer's installation standards.

Asphalt Shingles

GENERAL ASPHALT SHINGLE ROOF MATERIAL INSTALLATION REQUIREMENTS	
Item	Requirement
Roof Slopes	2:12 or greater
Decking/ Sheathing	Deck shall be of solid sheathing
Roofing Material Application	In accordance with the manufacture's requirements
Fasteners	Galvanized steel, stainless steel, aluminum or copper roofing nails, min. 12 gage shank with a minimum 3/8" diameter head of a length to penetrate through the roofing materials and a minimum of 3/4" into the roof sheathing.
Attachment	Asphalt shingles shall have the min. number of fasteners required by the manufacturer, but not less than 4 fasteners per strip shingle or 2 fasteners per individual shingle.
Underlayment Application	For roof slopes from 2:12 to 4:12, underlayment shall be 2 layers of underlayment felt applied in a 19" strip of parallel to and starting at the eaves, fastened sufficiently to hold in place. Starting at the eave, apply 36" -wide sheets of underlayment, overlapping successive sheets 19" and fastened sufficiently to hold in place. For roof sloped 4:14 or greater, underlayment shall be one of underlayment felt applied shingle fashion, parallel to and starting from the eave and lapped" fastened sufficiently to hold in place.
Flashing - Open Valleys	Valley lining shall be at least 24" wide and of corrosion resistant metal. When lined with two plies of approved mineral-surfaced roll roofing, the bottom layer shall be 18" wide and the top layer shall be 36" wide.
Flashing - Closed Valleys	One ply of smooth roll roofing at least 36" wide. Or either method described above for open valleys.
Flashing - Other Locations	Flashing against a vertical front wall, as well as soil stack, vent pipe and chimney flashing, shall be applied according to the asphalt shingle manufacturer's instructions.

Wood Shingles

GENERAL WOOD SHINGLES ROOF MATERIAL INSTALLATION REQUIREMENTS	
Item	Requirement
Roof Slopes	3:12 and greater
Decking/ Sheathing	Solid or spaced sheathing. Where spaced sheathing is used, sheathing board shall be a minimum of 1" x 4" and shall be spaced on centers equal to coincide with the placement of shingle fasteners.
Roofing Material	Wood shingles shall be laid with a side lap of not less than 1 1/2" between

Application	joints in adjacent courses, and not in direct alignment in alternate courses. Spacing between shingles shall be not less than ¼” or more than 3/8”.
Fasteners	Fasteners shall be corrosion resistant with a min. penetration of ½” into the sheathing.
Attachment	Wood shingles shall be attached to the roof with 2 fasteners per shingle, positioned no more than ¾” from each edge and no more than 1” above the exposure line.
Underlayment Application	In accordance with the manufacture’s requirements.
Flashing - Valleys	Valley flashing shall extend a minimum of 10” from the centerline each way for roofs having slopes less than 12:12. Flashing shall have an end lap of 4” minimum.
Flashing - Other Locations	At the juncture of the roof and vertical surfaces, flashing and counter-flashing shall be provided in accordance with the instructions.

Wood Shake

GENERAL WOOD SHAKE ROOF MATERIAL INSTALLATION REQUIREMENTS	
Wood	Requirement
Roof Slopes	3:12 and greater
Decking/ Sheathing	Wood shingles shall be installed on solid or spaced sheathing. Where spaced sheathing is used, sheathing board shall be a minimum of 1” x 4” and shall be spaced on centers equal to coincide with the placement of shingle fasteners. Where 1” x 4” sheathing is installed at 10” on center, additional 1” x 4” boards shall be installed between the sheathing boards.
Roofing Material Application	Shakes shall be laid with a side lap of not less than 1½” between joints in adjacent courses. Spacing between shakes shall not be less than 3/8” nor more than 5/8”. The starter course at the eaves shall be doubled. The bottom or first layer may be either 15”, 18”, or 24” wood shakes or wood shingles. Fifteen-inch or 18” shakes may be used for the final course at the ridge. Shakes shall be laid with not less than 18” wide strips of not less than No. 30 felt shingles between each course in such a manner that no felt is exposed to the weather below the shake butts.
Fasteners	Fasteners shall be corrosion resistant with a min. penetration of ½” into the sheathing.
Attachment	Wood shakes shall be attached to the roof with 2 fasteners per shake, positioned no more than 1” from each edge and no more than 2” above the exposure line.
Underlayment Application	In accordance with the manufacture’s requirements.
Flashing - Valleys	Valley flashing shall extend a minimum of 10” from the centerline each way. Flashing shall have an end lap of 4” minimum
Flashing - Other Locations	At the juncture of the roof and vertical surfaces, flashing and counter-flashing shall be provided in accordance with the instructions.

EXTERIOR DOORS AND GARAGE DOORS

Exterior Doors

One egress door is required for each dwelling unit that is side-hinged and provides a minimum clear opening width of 32 inches (typically a 36 inch door) and 6.5 feet in

clear height. The egress door shall have a landing that is a minimum of 36 inches in the direction of travel, a minimum width that is equal to the size of the door opening, and a maximum of 7- $\frac{3}{4}$ inches below the top of the threshold (when the door swings in).

All exterior doors, including the door between the house and garage, other than the egress door shall have a landing that is a minimum of 36 inches in the direction of travel, a minimum width that is equal to the size of the door opening, and a maximum of 7- $\frac{3}{4}$ inches below the top of the threshold (regardless of which direction the door swings).

Each exterior door shall have an exterior lighting fixture controlled by a switch. Outdoor lighting fixtures shall comply with the energy efficiency requirements as described in Energy Conservation Requirements section of this book.

EXTERIOR WALL COVERINGS

Weather Protection

Exterior walls shall provide the building with a weather-resistant exterior wall envelope. The exterior wall envelope shall include flashing to prevent the accumulation of water within the wall assembly by providing a water-resistive barrier behind the exterior veneer, and a means for draining water that enters the assembly to the exterior.

A minimum of one layer of No. 15 asphalt felt shall be attached to the studs or sheathing to provide a continuous water-resistive barrier behind the exterior wood veneer. Building paper and felt shall be free from holes and breaks and shall be applied over studs or sheathing of all exterior walls. Felt or paper shall be applied horizontally, with the upper layer lapped over the lower layer not less than 2 inches. Where vertical joints occur, laps shall be not less than 6 inches.

Weather-resistive barrier may be omitted in the following cases:

- In detached accessory buildings.
- Under approved fiber cement siding
- Under approved paperbacked metal or wire fabric lath.

Exterior Plaster (Stucco)

When exterior plaster (stucco) is installed it shall be a minimum 3-coat, 7/8 inch thick and installed over two layers of Grade D building paper and wire lath. Lath shall be attached with one of the following methods:

- with 1-1/2 inch long, 11-gage nails, having a 7/16 inch head,
- 7/8 inch long, 16 gage staples, spaced at no more than 6 inches, or
- as otherwise approved.

A minimum 26 gage galvanized sheet metal, corrosion-resistant weep screed with a minimum vertical attachment flange of 3-1/2 inches shall be provided at or below the

foundation plate line on exterior stud walls. The weep screed shall be a minimum of 4 inches above earth or 2 inches above paved areas. The water-resistant building paper shall lap the attachment flange. The exterior lath shall cover and terminate on the attachment flange of the weep screed.

The following illustrates these requirements:

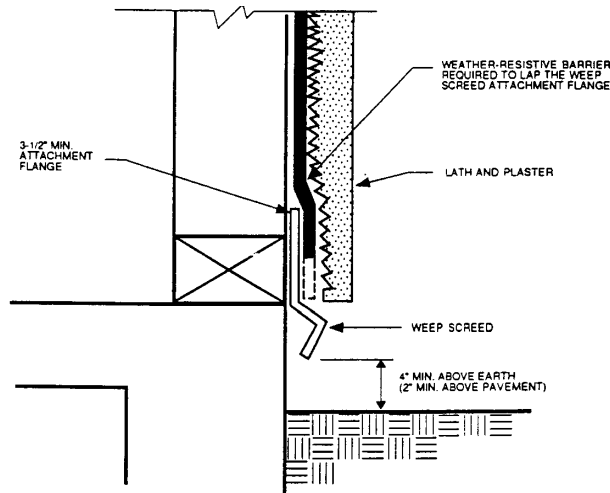

Exterior Siding

Exterior siding shall be applied over one layer of 15-pound asphalt-saturated felt or other approved waterproof paper.

Exterior Veneer

Masonry veneer shall be supported upon the footings and attached to the structural wall with corrosion-resistant metal ties. Each tie shall support not more than 2 square feet of wall area. Veneer over openings shall be supported upon lintels on non-corrosive non-combustible material.

Exterior Openings

Exterior openings exposed to weather shall be flashed with rust-resistant metal or other approved flashing in such a manner to make them waterproof.

SKYLIGHTS

Operable skylights shall be 10 feet from all plumbing vents or the vent shall terminate 3 feet above the skylight. Operable skylights shall be a minimum of 3 feet from any environmental air vent (i.e. stove hood, bathroom fan, etc.)

Plastic skylights shall be a minimum of 4 feet from each other, unless:

- the skylights are located within the same room or space and the maximum area of the skylights is 100 square feet, or
- the building is equipped throughout with an automatic fire sprinkler system.

Joists and rafters shall be doubled when adjacent to any joists or rafters cut in order to install a skylight. If roof framing is engineered trusses, they shall not be cut without details provided by a licensed civil engineer and approved by the Building Division.

FIREPLACES AND CHIMNEYS

Fireplaces

The Sunnyvale Municipal Code requires that any newly installed wood burning fireplace comply with the U.S. EPA Phase II emissions limits. Existing and lawful wood burning fireplace can be repaired, reconstructed, or remodeled.

Masonry fireplaces shall be provided with a brick, concrete, stone or other non-combustible hearth slab not less than 4 inches thick. Hearths extensions shall be as follows:

REQUIRED HEARTH EXTENSIONS		
Size of Fireplace Opening	Front Hearth Dimension	Side Hearth Dimension
6 sq. ft or less	16 inches min.	8 inches min.
6 sq. ft or larger	20 inches min.	12 inches min.

The following illustrates the hearth requirements:

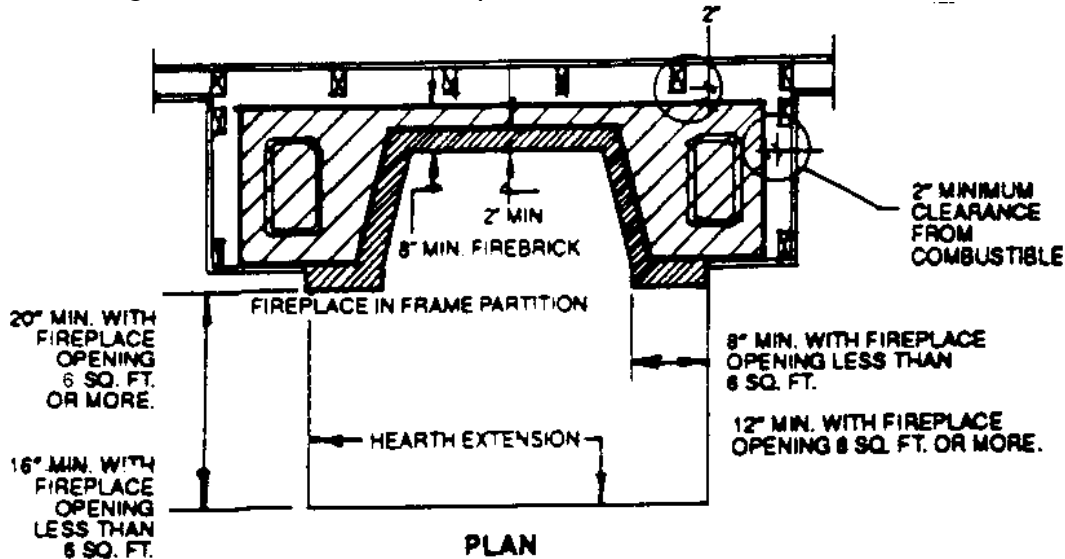

Exposed combustible mantels or trim shall not be placed within 6 inches of the fireplace opening. Combustible material within 12 inches of the fireplace opening shall not project more than 1/8 inch for each 1 inch of clearance from the fireplace opening.

Factory-built Fireplaces and Pellet Fueled Wood Heaters

Factory-built fireplace units and pellet fueled wood heaters may be used provided such units are installed in accordance with approved standards, the units meet the U.S. EPA Phase II emission limits (if wood-burning), and are ICC listed or UL listed.

Masonry Chimneys

Masonry chimneys shall be constructed of concrete or masonry. Masonry chimneys shall be constructed, anchored, supported, and reinforced as required by the 2010 California Residential Code. Masonry chimneys are required to be designed by an architect or engineer licensed by the State of California.

Chimneys shall have a clay flue lining that extends from the top of the smoke chamber to a point above the enclosing walls.

Chimneys shall extend to a point at least 2 feet above any portion of the building within 10 feet of the chimney, but shall not be less than 3 feet above the highest point where the chimney passes through the roof. Each chimney shall terminate in an approved spark arrestor. The spark arrestor shall be minimum 12 gauge welded or woven wire-mesh with a maximum opening of $\frac{1}{2}$ inch.

At each floor or ceiling line 2 anchorage straps consisting of $\frac{3}{16}$ inches by 1 inch steel cast at least 12 inches into the chimney. Straps shall be hooked around the outer bars and extend 6 inches beyond the bend. Each strap shall be fastened to a minimum of 4 joists or rafters with two $\frac{1}{2}$ inch bolts.

Clean out openings shall be provided at the base of every chimney.

Following is a typical chimney section and a table that describes the specific requirements:

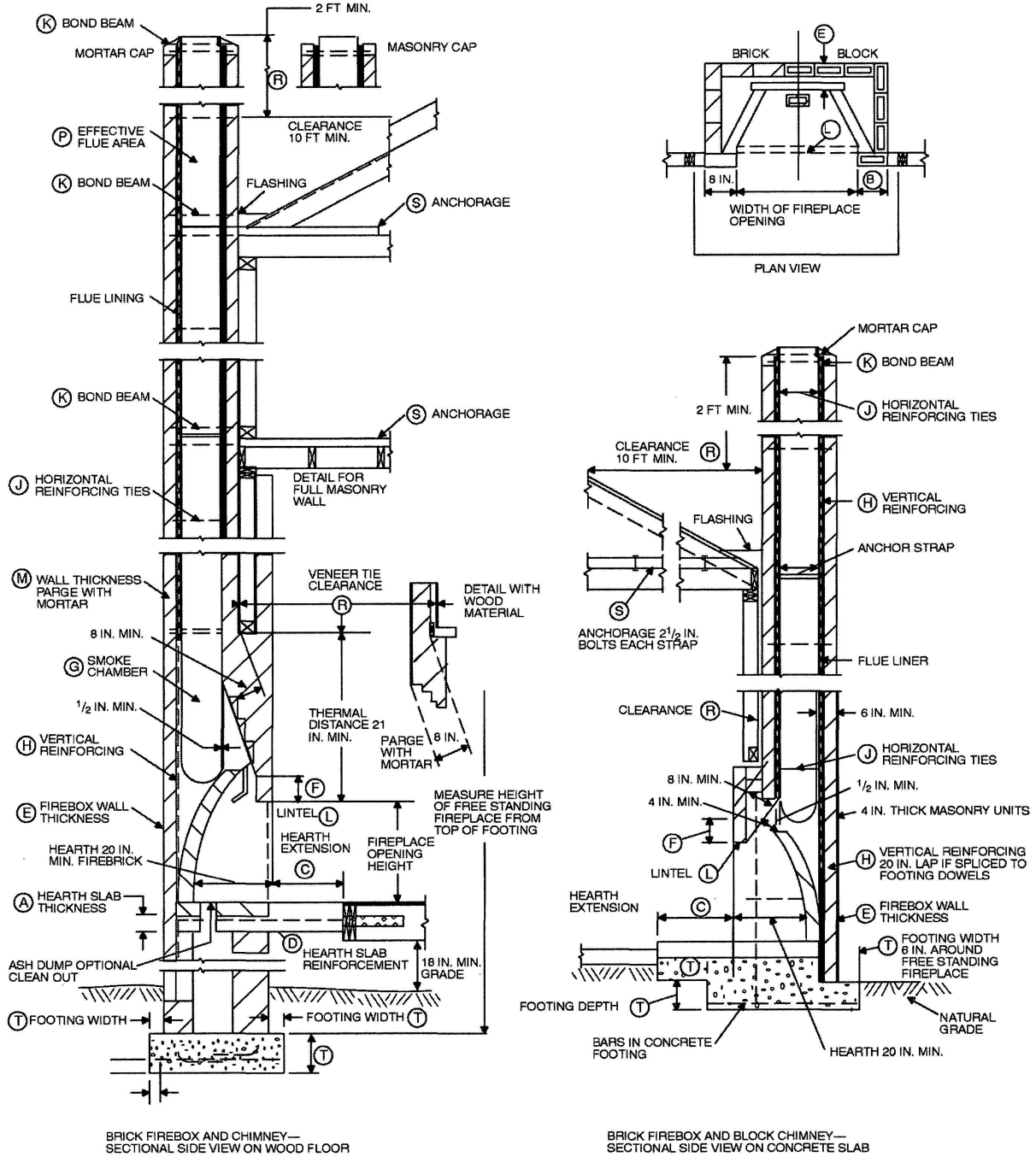

SI: 1 inch = 25.4 mm, 1 foot = 304.8 mm.

**FIGURE R1001.1
FIREPLACE AND CHIMNEY DETAILS**

Note: Structural calculations and diagonal bracing may be required for heights more than 5 feet above the roofline.

SUMMARY OF REQUIREMENTS FOR MASONRY FIREPLACES AND CHIMNEYS		
Item	Letter	Requirements
Hearth slab thickness	A	4"
Hearth extension (each side of opening)	B	8" fireplace opening < 6 square foot. 12" fireplace opening ≥ 6 square foot.
Hearth extension (front of opening)	C	16" fireplace opening < 6 square foot. 20" fireplace opening ≥ 6 square foot.
Hearth slab reinforcing	D	Reinforced to carry its own weight and all imposed loads.
Thickness of wall of firebox	E	10" solid brick or 8" where a firebrick lining is used. Joints in firebrick ¼" maximum.
Distance from top of opening to throat	F	8"
Smoke chamber wall thickness Unlined walls	G	6" 8"
Chimney Vertical reinforcing	H	Four No. 4 full-length bars for chimney up to 40" wide. Add two No. 4 bars for each additional 40" or fraction of width or each additional flue.
Horizontal reinforcing	J	¼" ties at 18" and two ties at each bend in vertical steel.
Bond beams	K	No specified requirements.
Fireplace lintel	L	Noncombustible material.
Chimney walls with flue lining	M	Solid masonry units or hollow masonry units grouted solid with at least 4" nominal thickness.
Distances between adjacent flues	-	See Section R1003.13.
Effective flue area (based on area of fireplace opening)	P	See Section R1003.15.
Clearances: Combustible material Mantel and trim Above roof	R	See Sections R1001.11 and R1003.18. See Section R1001.11, Exception 4. 3' at roofline and 2' at 10'
Anchorage Strap Number Embedment into chimney Fasten to Bolts	S	3/16" x 1" Two 12" hooked around outer bar with 6" extension. 4 joists Two ½" diameter
Footing Thickness Width	T	12" min. 6" each side of fireplace wall.

Note: This table provides a summary of major requirements for the construction of masonry chimneys and fireplaces. Letter references are to Figure R100 1.1, which shows examples of typical construction. This table does not cover all requirements, nor does it cover all aspects of the indicated requirements. For the actual mandatory requirements of the code, see the indicated section of text.

INTERIOR SPACE REQUIREMENTS

FIRE-RESISTIVE CONSTRUCTION BETWEEN A DWELLING AND GARAGE

The common walls between a private garage and a dwelling unit shall have 1/2 inch sheetrock installed on the garage side extending to the roof. When habitable space is located above a garage, the ceiling of the garage shall have 5/8 inches type X sheetrock installed. Any openings between the garage and dwelling unit shall have a solid core door that is self-closing, self-latching, 1-3/8 inches thick or a 20 minute rated metal door that is self-closing. Such doors cannot open into a sleeping room.

A fire-resistive separation between the carport and dwelling is not required when the carport is fully open on two or more sides and with no enclosed areas above.

WINDOWS

Emergency Escape Windows (Egress)

Basements and every sleeping room shall have at least one operable window or door approved for emergency escape or rescue that shall open directly into a public way, or to a yard/court that opens to a public way. The emergency door or window shall be operable from the inside to provide a full clear opening without the use of separate tools.

All escape or rescue windows shall meet the following requirements:

- Minimum net 5.7 square feet of operable area (minimum of 5.0 net square feet required for grade level bedrooms; i.e. first floor)
- Minimum net 20 inches clear width when open, or minimum net 24 inches clear height when open
- Maximum height of 44 inches from the finished floor to the bottom of the clear opening

Escape and rescue windows with a finished sill height below the adjacent ground elevation (i.e. basement windows) shall have a window well. Window wells at escape or rescue windows shall comply with the following:

- The clear horizontal dimension shall allow the window to be fully opened and provide a minimum accessible net clear opening of 9 square feet with a minimum dimension of 36 inches.
- Window wells with a vertical depth of more than 44 inches shall be equipped with an approved permanently affixed ladder or stairs that are accessible with the window in the fully open position. The ladder or stairs shall not encroach into the required dimension of the window well by more than 6 inches.

Emergency escape window requirements are illustrated below:

Examples of
EGRESS WINDOW DIMENSIONS

Above Grade 5.7 sq. ft.	
Width	Height
20	41
20 ½	40
21	39 ¾
21 ½	38 ¾
22	37 ¾
22 ½	36 ¾
23	35 ¾
23 ½	34 ¾
24	34 ¾
24 ½	33 ¾
25	32 ¾
25 ½	32 ¾
26	31 ¾
26 ½	31
27	30 ¾
27 ½	29 ¾
28	29 ¾
28 ½	28 ¾
29	28 ¾
29 ½	27 ¾
30	27 ¾
30 ½	26 ¾
31	26 ½
31 ½	26 ½
32	25 ½
32 ½	25 ½
33	24 ¾
33 ½	24 ¾
34	24 ¾

At Grade * 5.0 sq. ft.	
Width	Height
20	36
20 ½	35 ¾
21	34 ¾
21 ½	33 ½
22	32 ¾
22 ½	32
23	31 ¾
23 ½	30 ¾
24	30
24 ½	29 ¾
25	28 ¾
25 ½	28 ¾
26	27 ¾
26 ½	27 ¾
27	26 ¾
27 ½	26 ¾
28	25 ¾
28 ½	25 ¾
29	24 ¾
29 ½	24 ¾
30	24

* Not more than 44"
above or below grade

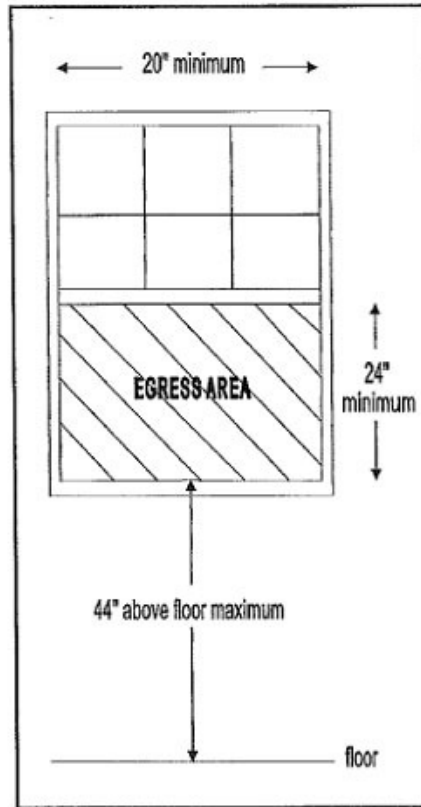

Bars, grilles, grates or similar devices may be installed on emergency escape or rescue windows, doors or window wells, provided the devices are equipped with approved release mechanisms that are operable from the inside without the use of a key or special knowledge or effort and

Safety Glazing

Safety glazing (i.e. tempered glass) shall be installed in the following locations:

- Within a 2 foot arc of either the edge of a door and where the bottom exposed edge of the glazing is less than 60 inches above the walking surface.
- Glazing in wall enclosing stairway landings or within 5 feet of the bottom and top of stairways where the bottom edge of the glazing is less than 60 inches above the walking surface.
- Glazing within a portion of wall enclosing a tub/shower where the bottom exposed edge of the glazing is less than 60 inches above the standing surface and drain inlet.
- Within 60 inches of a tub/shower where the glazing is less than 60 inches above the walking surface.
- Any glazing meeting all the following conditions:
 - Exposed area of an individual pane greater than 9 square feet
 - Exposed bottom edge is less than 18 inches above the finished floor
 - Exposed top edge is greater than 36 inches above the finished floor

- Where a walking surface is within 36 inches horizontally of the glazing

Where required, safety glazing (except tempered spandrel glass) shall be permanently identified by a manufacturer marking that is permanently applied and cannot be removed without being destroyed (e.g. sand blasted, acid etched, ceramic fired, laser etched, or embossed). Stickers attached to the window are not sufficient.

Protective Guardrails

Windows with an opening (measured at the window sill) located more than 72 inches above the exterior finished grade and where the window is located less than 24 inches above the finished floor on the interior shall have either a permanent window opening control device, an approved fall prevention device, or fixed glazing.

See illustration below for guardrail requirements:

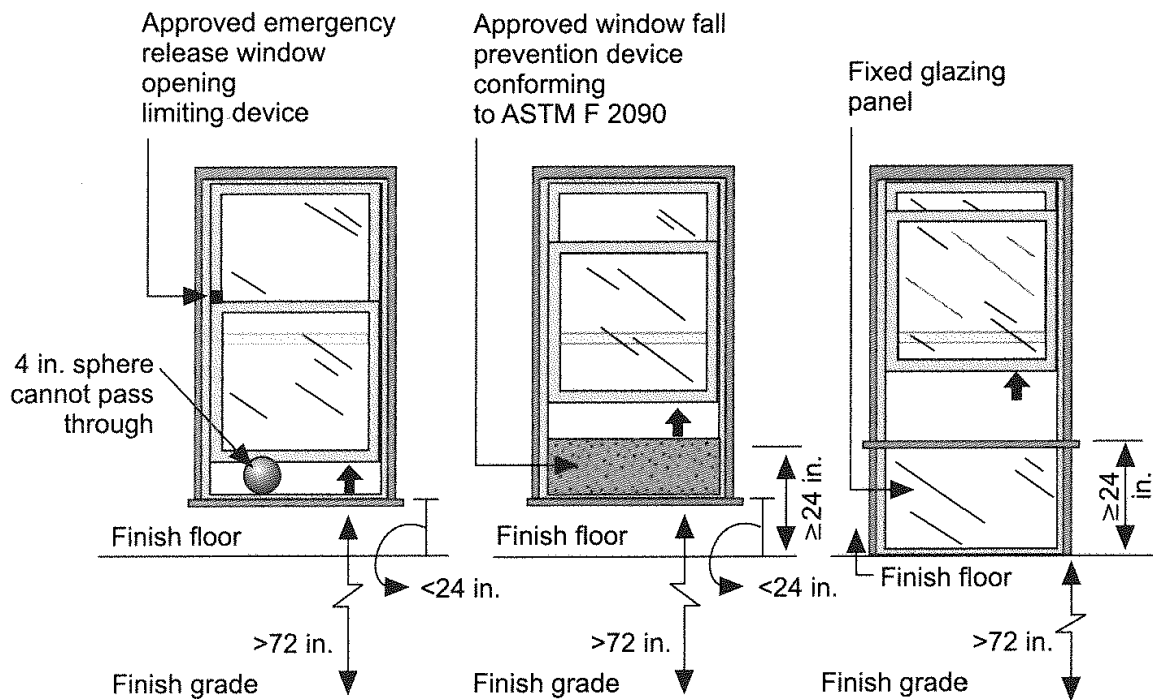

LIGHT AND VENTILATION

For the purpose of determining light and ventilation requirements any room may be considered as a portion of an adjoining room when one half of the area of the common wall is open and unobstructed providing an opening of not less than 1/10 of the floor area of the interior room or 25 square feet, whichever is greater.

Light

Every room shall be provided with natural light by means of exterior glazed opening with an area not less than 8% of the floor area of such rooms. For natural lighting purposes, any room is permitted to serve as a portion of another room provided half of

the common wall is open and provides an opening on not less than 1/10 of the floor area of the interior room, or 25 square feet, whichever is greater.

In lieu of natural light, artificial light may be provide that is adequate to provide average illumination of 6 foot-candles over the area fo the room at a height of 30 inches above the floor.

Ventilation

Every room shall be provided with natural ventilation by means of operable exterior openings with an area of not less than 4% of the floor area of such rooms. When ventilation is provded through an adjoining room, the opening between the rooms shall be clear and not less than 8% of the interior room or 25 square feet, whichever is greater.

Bathrooms, water closet compartments, and similar rooms shall be provided with natural ventilation by means of operable exterior openings with an area not less than 3 square feet.

In lieu of required exterior opening for natural ventilation, a mechanical ventilating system may be provided. Such ventilations system shall be capable of producing 0.35 air changes per hour when installed in a single room or a whole-house ventilation system capable of supplying outdoor ventilations air at a rate of 15 cubic feet per minute per occupant (for purposes of this section, assume two occupants for the first bedroom and one occupant for each additional bedroom).

In lieu of required exterior openings for natural ventilation in bathrooms water closet compartments, and similar rooms a mechanical ventilation system connected directly to the outside capable of providing ventilation at a rate of 50 cubic feet per minute for intermittent ventilation or 20 cubic feet per minute for continuous ventilation.

INTERIOR SPACE DIMENSIONS

Size of Rooms

Dwelling units must have at least one room, which has no less than 120 square feet of floor area. Other habitable rooms (except kitchens) shall have an area of not less than 70 square feet.

Habitable spaces, other than kitchens, shall not be less than 7 feet in any dimension.

Bathrooms

The water closet shall have a minimum clearance of 30 inches in width (fixture is to be centered with a minimum of 15 inches clear on each side) and 24 inches clear in the front.

Shower stalls shall have a minimum finished interior space of 1,024 square inches and shall have a clear center dimension of 30 inches. The shower door shall be a minimum of 22 inches in width.

Ceiling Height

Following table describes the minimum ceiling height requirements for various rooms:

MINIMUM CEILING HEIGHT	
Room	Minimum Ceiling Height
Habitable spaces, hallways, bathrooms, toilet rooms, kitchen, and laundry rooms	7 feet In rooms with a sloping ceiling, the 7 feet height shall be provided in at least 50 percent of the area and no portion of the required floor area shall have a ceiling height of less than 5 feet.
Bathrooms	6 feet 8 inches at the front clearance area for the fixtures and at the shower or tub equipped with a showerhead

STAIRWAYS

The width of private residential stairways may not be less than 36 inches and clear of all obstructions except handrail. The rise of stairs shall not be more than 7-¾ inches and the tread shall not be less than 10 inches exclusive of the nosing. The maximum variation between the greatest and smallest tread height and depth within the same flight of stairs shall be 3/8 inch.

Headroom clearance shall be not less than 6 feet 8 inches measured vertically from nosing to the nearest ceiling.

There shall be a floor or landing at the top and bottom of each stairway or stair run. Landings shall have a width not less than the width of the stairs and a minimum 36 inch length in the direction of travel.

See illustration below for stair requirements:

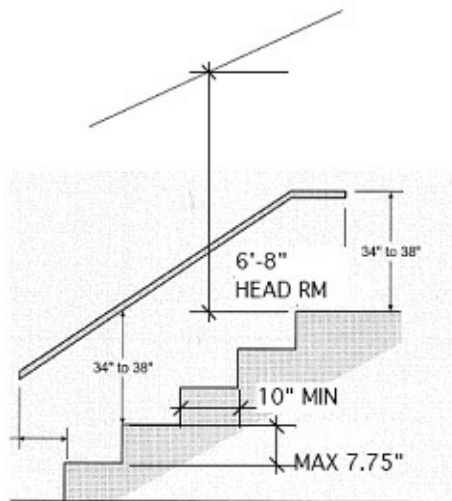

Winder Treads

Winder treads and risers that occur in a portion of the stairway that turns or curves. See illustration below for winder tread requirements in angled stairways:

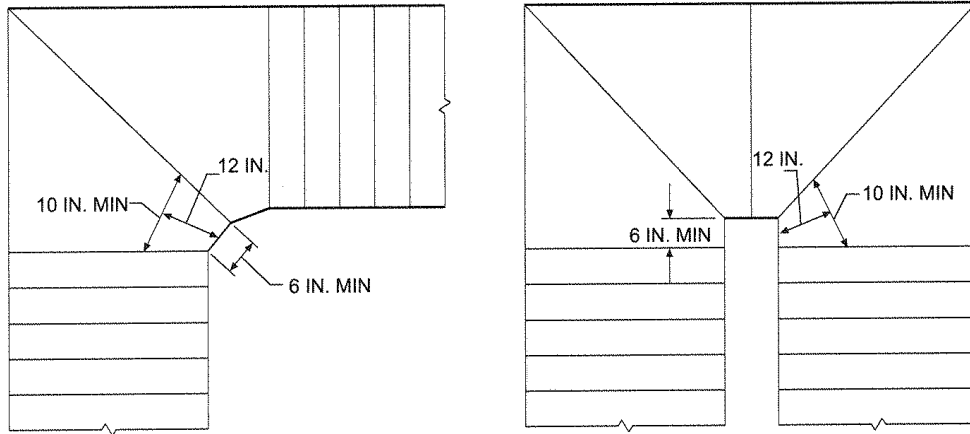

See illustration below for winder tread requirements in circular stairways:

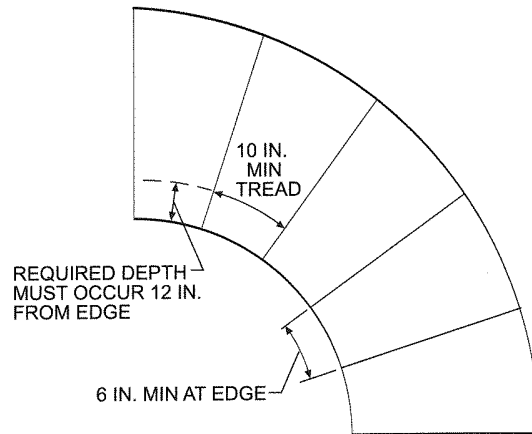

Handrails

Stairways having 4 or more risers shall be provided with minimum of one handrail. Such handrail shall be placed not less than 34 inches or more than 38 inches above the nosing of treads and the ends of handrails shall be returned or shall terminate in posts or safety terminals. Handrails shall not project more than 4.5 inches on either side of the stairway.

All handrails shall be either Type I or Type II, or shall provide equivalent graspability, as illustrated below:

Type I Handrail

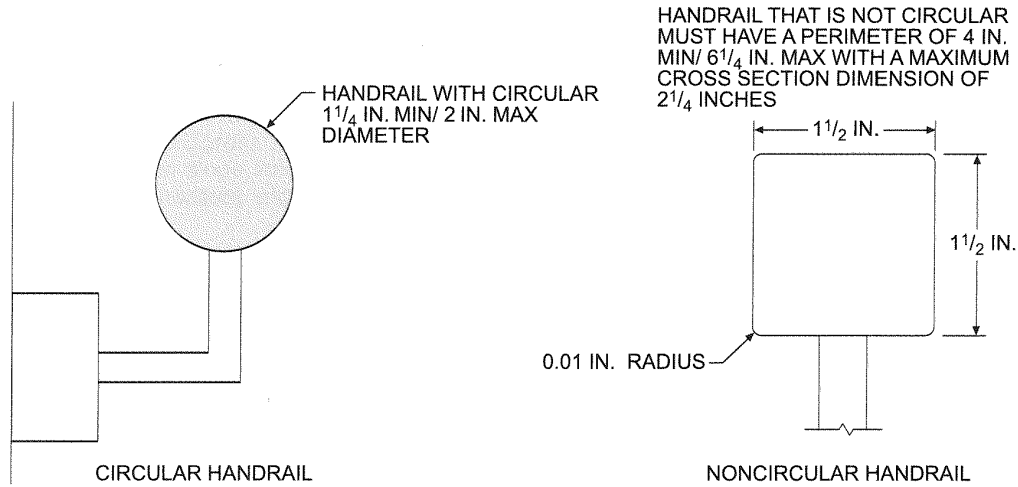

Type II Handrail HANDRAIL PERIMETER > 6 1/4 IN.

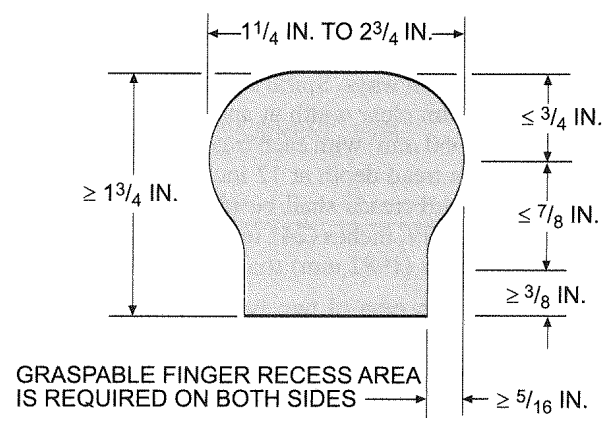

GUARDRAILS

Guardrails shall be provided along open-sided walking surfaces, mezzanines, stairways, ramps, balconies, landings, porches. And other areas that are more than 30 inches above the floor or grade level. Such railing shall be not less than 42 inches in height above the floor. The intermediate members in open type railing shall be spaced so a 4 inch sphere can not pass through.

Exception 1: Guardrails on the open sides of stairs shall have a height not less than 34 inches measured vertically from a line connecting the leading edges of the treads.

Exception: Guardrails that also serve as a handrail shall have a height of 34 inches to 38 inches measured vertically from the leading edge of the stair tread nosing.

Guardrail requirements are illustrated below:

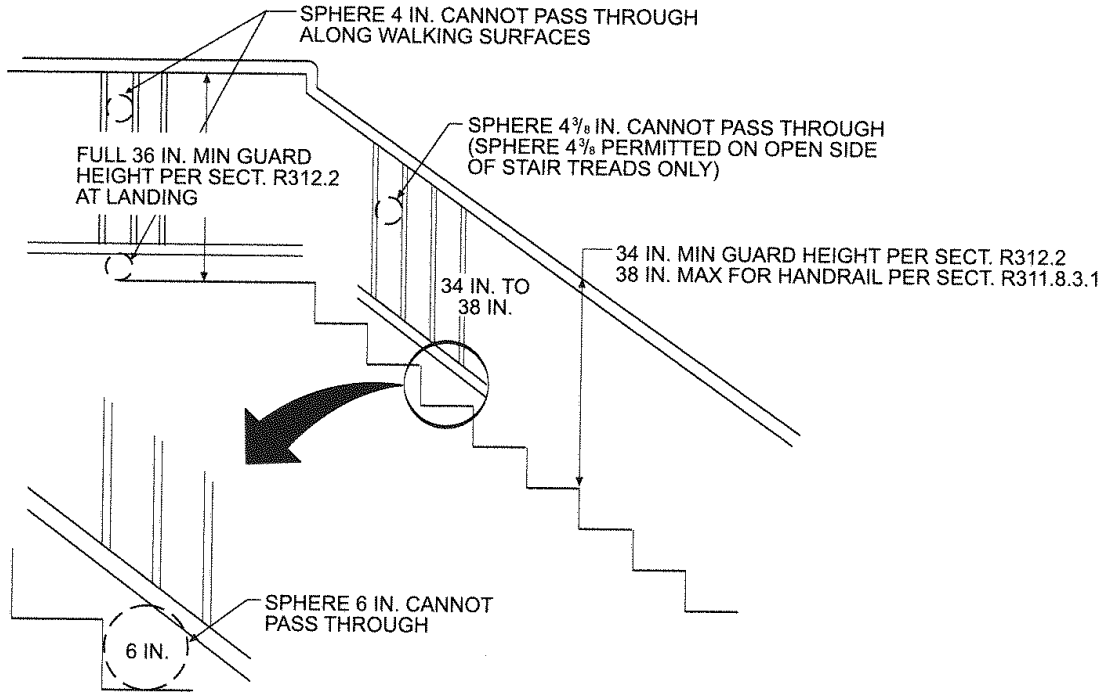

WALLBOARD

Gypsum wallboard shall be not less than 1/2 inch thick and shall be nailed as set forth in the table below. All edges and ends of wallboard shall occur over nailing members except for treated joints at right angles to framing members.

APPLICATION OF SINGLE-PLY GYPSUM WALLBOARD					
Thickness of Gypsum Wallboard (inches)	Plane of Framing Surface	Long Dimension of Gypsum Wallboard Sheets in Relation to Direction of Framing Members	Maximum Spacing of Framing Member (o.c.)	Maximum Spacing of Nails (o.c.)	Maximum Spacing of Screws ¹ (o.c.)
1/2"	Vertical	Either Direction	16"	8"	16"
1/2"	Horizontal	Either Direction	16"	7"	12"
1/2"	Vertical	Either Direction	24"	8"	12"
1/2"	Horizontal	Perpendicular	24"	7"	12"
5/8"	Vertical	Either Direction	16"	8"	16"
5/8"	Horizontal	Either Direction	16"	7"	12"
5/8"	Vertical	Either Direction	24"	8"	12"
5/8"	Horizontal	Perpendicular	24"	7"	12"

¹ Screws shall be of an approved type long enough to penetrate into wood framing not less than 5/8 inch and through metal framing (maximum thickness of 0.033 inches) not less than 3/8 inch.

When gypsum is used as a base for tile or wall panels for tub, shower or water closet compartment walls, water-resistant gypsum backing board shall be used. Water-resistant gypsum board shall not be used in the following locations:

- Over a vapor retarder
- In areas subject to continuous high humidity, such as saunas or steam rooms
- On ceilings where frame spacing exceeds 12 inches on center

For information regarding gypsum wallboard installed in a garage adjacent to a dwelling, please refer to the section on this book titled *Fire-Resistive Construction Between a Dwelling and a Garage*.

CLOTHES DRYER VENTILATION

Moisture exhaust ducts for clothes dryers shall terminate outside of the building and have a back-draft damper. Such ducts shall be metal with a smooth interior surface and shall not contain sheet metal screws or other fasteners that obstruct the flow.

Clothes dryer ducts shall have a maximum length of 14 feet including two 90 degree elbows. Where more than two 90 degree elbows exist, 2 feet shall be deducted from the maximum length of each additional 90 degree elbow.

When a clothes dryer is installed in a closet or compartment, the exhaust duct shall be a minimum of 4 inches in diameter. The closet or compartment shall also have a minimum opening of 100 square inches for make up air.

ELECTRICAL REQUIREMENTS

The following information is provided as general requirements for individual dwelling units. For more specific information, consult the 2010 California Electrical Code or the Building Safety Division.

INSTALLATION OF ELECTRICAL SERVICE

The main electrical service shall be installed with rigid conduit. Electrical metallic tubing may be used where the service drop is attached to the building. The service entrance cable may be used, provided the approved fittings are used with the cable, such as a rain-tight service head or forming the cable goose-neck, taped or painted, and held securely in place by a fitting approved for the purpose.

The minimum size service conduit shall be 1-1/4 inch. The minimum size service entrance wire shall be rated 100 amperes minimum if the load is 10 kW or more, or has more than six two-wire branch circuits. A larger service may be required for new homes or additions to existing homes. See *Electrical Load Estimating Worksheet* in the Appendix to determine the minimum electrical service required. It is recommended that spare electrical capacity be installed to allow for the addition of future electrical equipment at minimum cost.

The service head shall be installed where directed by the serving agency (Pacific Gas and Electric - PG&E), and a substantial support for the drops shall be provided at a

single point of attachment. The attachment of the drop shall be below the service head and drip loops formed to prevent moisture entering the conduit.

Electrical service for new construction shall be installed underground.

Conductors and cables exposed to direct sunlight, including overhead service conductors, shall be listed and marked as “sunlight resistant.” Service entrance conductors shall be sized as follows:

SERVICE ENTRANCE CONDUCTORS SIZE AND RATING		
Service or Feeder Rating	Copper Conductors	Aluminum or Copper-Clad Aluminum
100 Amps	#4 AWG	#2 AWG
125 Amps	#2 AWG	#1/0 AWG
150 Amps	#1 AWG	#2/0 AWG
200 Amps	#2/0 AWG	#4/0 AWG

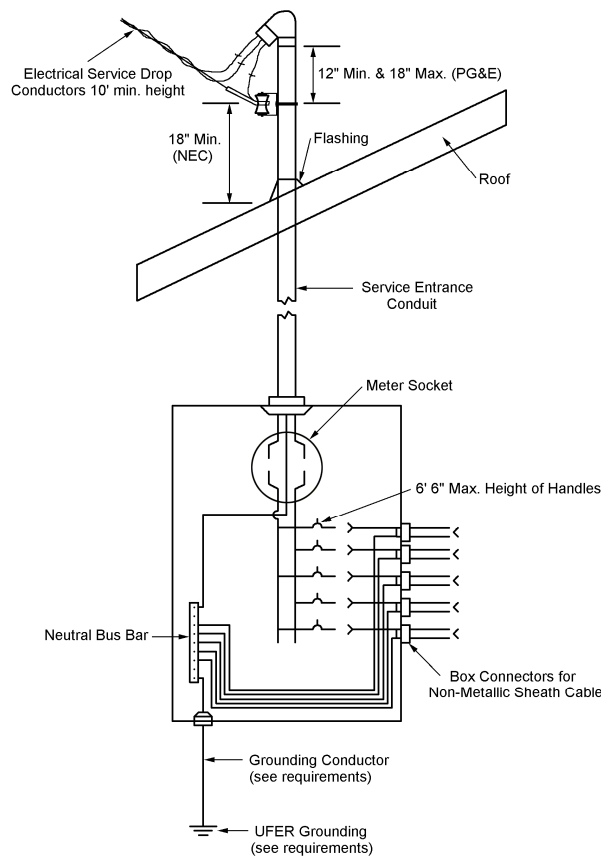

Clearance of Service Conductors (Wires)

Conductors shall have a vertical clearance of not less than 8 feet above the roof surfaces. The service head shall be so located that the service drops together with the open wires between the service head and service drop will have a minimum clearance of 10 feet vertically above ground and 3 feet radius from doors and windows.

A minimum clearance of 10 feet is required for service drops passing over buildings including premises being served, except as follows:

Exception No. 1: If the roof has a slope of not less than 4 inches in 12 inches, a reduction in clearance of 3 feet is permitted.

Exception No. 2: A reduction in clearance above only the overhanging portion of the roof to not less than 18 inches is permitted if not more than 6 feet of service-drop conductors, 4 feet horizontally, pass over the roof overhang and they are terminated at a through-the-roof raceway or approved support.

Location of Main Switch

Service switches shall be installed at the nearest readily accessible point to the entrance of the service wires. The maximum height of the service switch or circuit breaker handle shall not exceed 6 feet 6 inches above ground and shall have a clear space of 3 feet in front and width, and 6 feet 3 inches headroom.

Grounding and Bonding of Services

Any work involving adding sub-panels, upgrade of electrical service, change of water service (if using a less conductive material than is existing), re-piping of a structure, or adding circuits (if no grounding system exists) will require upgrading of the grounding and bonding of the electrical service.

Grounding shall consist of a continuous grounding electrode conductor run from the panel to a ground rod (grounding electrode) and to the cold water pipe. Grounding of the electrical service at the main water line must be within the first 5 feet of water piping into the building. The underground water service shall not be used as the grounding electrode without supplemental electrode.

For new structures and additions to existing structures, a concrete encased ground electrode shall be installed. This shall consist of 20 feet of ½ inch bare or zinc-coated rebar or bare copper wire in the portion of the footing in contact with earth.

For existing structures, the grounding electrode shall be nonferrous (copper), listed, and not be less than ½ inch in diameter. The electrode shall be installed such that at least 8 foot of length is in contract with the soil. The upper end of the electrode shall be flush with or below ground level unless the above-ground end and the grounding electrode conductor attachment is protected against physical damage.

The required grounding electrode conductor (from electrode to panel) size is listed in the following table:

GROUNDING ELECTRODE CONDUCTOR SIZING		
Size of Main Panel	Copper Conductors	Aluminum or Copper-Clad Aluminum
100 Amps	#8 AWG	#6 AWG
125 Amps	#8 AWG	#6 AWG
150 Amps	#6 AWG	#4 AWG
200 Amps	#4 AWG	#2 AWG

Bonding shall consist of a continuous bond jumper installed at the water heater between the hot, cold, and gas lines. The bonding jumper shall be sized based on the following table:

BONDING JUMPER SIZING		
Size of Main Panel	Copper Conductors	Aluminum or Copper-Clad Aluminum
100 Amps	#8 AWG	#6 AWG
125 Amps	#6 AWG	#4 AWG
150 Amps	#6 AWG	#4 AWG
200 Amps	#6 AWG	#4 AWG

RECEPTACLE INSTALLATION

All receptacles shall be grounded with the ground wire carried with the branch circuit. All new or replacement receptacles shall be Tamper-Resistant (TR).

Wires shall be of adequate size for supplying their connected load. Wires shall be considered as properly protected when the protective device is set at a rating that does not exceed the allowable current carrying capacity as noted in the following table:

CURRENT CARRYING CAPACITY	
Breaker Size	Wire Gauge
15 amp	14
20 amp	12

Receptacle Locations

Receptacle outlets shall be provided and installed in every kitchen, dining room, breakfast room, living room, parlor, library, den, sunroom, recreation room, family room and bedroom, or similar room or area of dwelling units. Receptacle outlets shall be installed so that no point along the floor line in any wall space is more than 6 feet measured horizontally from an outlet in that space including any walls 2 feet wide.

The receptacle outlets shall, insofar as practicable, be spaced equal distance apart. Receptacle outlets in the floor shall not be counted as part of the required number of receptacle outlets unless located within 18 inches of the wall.

Kitchens

In the kitchen, pantry, breakfast room, dining room, or similar area two or more 20-ampere shall appliance branch circuits shall serve all receptacle outlets and outlets for refrigeration equipment. The small appliance branch circuits shall have no other outlets.

Counter top receptacles shall be located above the counter and not more than 20 inches above the finished counter top surface. Receptacles shall not be installed in a face-up position in the work surfaces or countertops.

The spacing for receptacle outlets for counter space shall be installed as noted in the following table:

KITCHEN COUNTERTOP RECEPTACLES	
Location	Requirements
Wall Counter Space	Receptacle outlets shall be installed so that no point along the wall line is more than 24 inches measured horizontally from a receptacle outlet in that space. A receptacle outlet shall be installed at each wall counter space 12 inches or wider.
Island Counter Space	At least one receptacle outlet shall be installed at each island counter space with a long dimension of 24 inches or greater and short dimension of 12 inches or greater.
Peninsular Counter Space	At least one receptacle outlet shall be installed at each peninsular counter space with a long dimension of 24 inches or greater and a short dimension of 12 inches or greater. A peninsular countertop is measured from the connection edge.
Separated Spaces	Countertop spaces separated by range tops, refrigerators, or sinks shall be considered as separate counter space in applying these requirements.
Receptacle Outlet Location	Receptacle outlets shall be located not more than 20 inches above the countertop. Receptacle outlets shall not be installed in a face-up position in the work surfaces or countertops. Receptacle outlets rendered not readily accessible by appliances fastened in place or appliances occupying dedicated space shall not be considered as these required outlets.

Bathrooms

At least one wall receptacle outlet shall be installed in bathrooms adjacent to each basin location. Bathroom receptacle outlets shall be supplied by one dedicated 20-ampere branch circuit. Receptacle outlets shall not be installed in a face-up position in the work surfaces or countertops.

Outdoor Outlets

At least one receptacle outlet shall be installed at the front and back of the house and be located not more than 6 feet 6 inches above grade. The enclosure for such receptacles shall be weatherproof whether or not the attachment plug cap is inserted (typically referred to as a bubble cover).

Balconies, decks, and porches shall have at least one receptacle installed not more than 6 feet 6 inches above the floor surface.

Laundry Areas

At least one receptacle outlet shall be installed for the laundry. The laundry receptacle(s) shall be on a dedicated 20-ampere branch circuit.

Garages and Unfinished Basements

At least one receptacle, in addition to those for specific equipment (i.e. laundry, heating equipment, etc.) shall be installed in each unfinished basement, attached and detached garage with electrical power.

Hallways

Hallways 10 feet or more in length shall have at least one receptacle outlet. The hall length shall be considered the length along the centerline of the hall without passing through a doorway.

Ranges and Cooking Appliances

Branch-circuit conductors supplying household ranges, wall-mounted ovens, counter-mounted cooking units and other cooking appliances shall have an ampacity not less than the maximum load to be served. For ranges of 8^{3/4} kW or more rating, the minimum branch-circuit rating shall be 40 amperes.

LIGHTING

At least one wall switch-controlled lighting outlet shall be installed in every habitable room, bathroom, hallways, stairways, attached garages, detached garages with electric power, and at exterior side of outdoor entrances or exits. A vehicle door in a garage shall not be considered as an outdoor entrance or exit.

At least one lighting outlet shall be installed in an attic, under floor space, utility room and basement when these spaces are used for storage or contain equipment which requires servicing.

Exception No. 1: In habitable rooms, other than kitchen and bathrooms, one or more receptacles controlled by a wall switch shall be permitted in lieu of lighting outlets.

Exception No. 2: In hallways, stairways, and at outdoor entrances, remote, central, or automatic control of lighting shall be permitted.

Exception No. 3: Lighting outlets shall be permitted to be controlled by occupancy sensors that are (1) in addition to wall switches, or (2) located

at a customary wall switch location and equipped with a manual override that will allow the sensor to function as a wall switch.

Bathrooms

Lighting fixtures located within 3 feet horizontally and 8 feet vertically of the bathtub rim or shower stall threshold shall be listed for a damp location, or listed for wet locations where subject to shower spray.

Recessed Lighting

All incandescent lighting fixtures recessed into insulated ceilings must include an approved zero-clearance insulation cover (IC-rated). Although this requirement does not apply to fluorescent fixtures, recessed lighting fixtures left un-insulated significantly increase the heat loss through the roof/ceiling area reducing the effectiveness of the insulation. Heat lamps are not required to be IC-rated.

Closet Lighting

Lighting fixtures installed in a closet shall be either incandescent with a sealed lens or fluorescent. Lighting fixtures shall be installed as follows:

CLOSET LIGHTING INSTALLATION		
Lighting Fixture Type and Location	Installation Location	Minimum Distance to Nearest Point of Storage
Fluorescent - Surface Mounted	On wall above door or on the ceiling.	6"
Incandescent - Surface Mounted	On wall above door or on the ceiling.	12"
Fluorescent - Recessed	Any wall or on the ceiling.	6"
Incandescent - Recessed	Any wall or on the ceiling.	6"

GROUND FAULT CIRCUIT INTERRUPTER – GFCI

Ground-Fault-Circuit-Interrupters (GFCI) are devices that function to interrupt the electrical current to the load when a fault current to ground exceeds a (very low) pre-determined value that is less than that required to operate the over-current protective device (i.e. fuse or breaker) of the supply circuit.

All 15 or 20 ampere receptacles installed in the locations specified below shall have ground-fault-circuit-interrupters protection for personnel:

- Bathrooms
- Garages and unfinished accessory buildings used for storage or work areas
- Outdoors
- Crawl spaces at or below grade level
- Unfinished basements. For purposes of this requirement, unfinished basements are defined as portions or areas of the basement not intended as habitable rooms and limited to storage areas, work areas, and the like.

- Kitchens, where the receptacles are installed to service the counter top surfaces.
- Laundry, utility, and wet bar sinks, where the receptacles are installed within 6 feet of the outside edge of the sink.

ARC FAULT CIRCUIT INTERRUPTER – AFCI

All branch circuits that supply 15- and 20- ampere outlets (lighting, switches, receptacles, smoke/carbon monoxide alarms, etc.) in family rooms, dining rooms, living rooms, dens, bedrooms, sunrooms, closets, hallways, or similar areas shall be protected by a combination arc-fault circuit interrupter. An arc-fault circuit interrupter is a circuit breaker device intended to provide protection from the effects of arc faults by recognizing characteristics unique to arcing and by functioning to de-energize the circuit when an arc fault is detected.

ELECTRICAL WIRING DETAILS

Raceways, cable assemblies, boxes, cabinets and fittings shall be securely fastened in place. Raceways and cable assemblies shall be continuous from outlet to outlet and from fitting to fitting. Wires in raceways shall be continuous from outlet to outlet and there shall be no splice or taps made within the raceway itself.

An approved box shall be installed at each outlet, switch point, splice or junction point of conduit, electrical metallic tubing, surface metal raceway, armored cable, or non-metallic sheathed cable. At least 6 inches of wire shall be left at each outlet and switch point for making up joints for the connection of fixtures or devices. Splices shall be electrically and mechanically secure.

Non-metallic sheathed cable may be used for both concealed and exposed work in normally dry locations. When used in exposed work, it must be protected from physical damage by covering or placing along running boards.

When in concealed work, wire cables are run through holes in studs, joists or similar wood members, holes shall be bored at the approximate center of wood members or at least 2 inches from nearest edge.

Outlet, switch and junction boxes, fittings and cabinets shall be securely fastened in place. Non-metallic boxes may be used only with a non-metallic wiring system. Metallic boxes used with non-metallic wiring systems shall be grounded when within 8 feet vertically or 5 feet horizontally of a grounded surface. Boxes and fitting installed in damp or wet locations shall be weatherproof. Outlet boxes for concealed work shall have a depth of at least 1½ inches. Where raceway or cable is used with metal boxes or fittings, the raceway or cable shall be secured to such boxes and fittings with approved clamps or connectors. Where non-metallic outlet boxes are used with non-metallic sheathed cable, clamping or individual cables to the box is not required if cable is secured within 8 inches of the box and covered.

Each outlet or junction box shall be provided with a cover. A metal plug shall effectively close unused openings in boxes and cabinets. In walls or ceilings constructed of wood or other combustible material, outlet boxes and fittings shall be flush with the finished surface. In walls of non-combustible materials boxes and fittings should be so installed that the front edge of the box or fitting will not set back more than 1/4 inch.

Junction boxes shall be installed in an accessible location with a minimum clearance of not less than 3 feet.

Electrical Cable Underground Installation

The following table lists the burial depth requirements for electrical cables installed underground:

MINIMUM COVER REQUIREMENTS (IN INCHES) FOR ELECTRICAL CABLE BURIAL					
Location or Wiring Method of Circuit	Direct Burial Cables or Conductors	Rigid Metal Conduit or Intermediate Metal Conduit	Non-metallic Raceways Listed for Direct Burial Without Concrete Encasement	Residential Branch Circuit, Maximum 120 Volts, with GFCI Protection, Maximum 20 Amps	Circuits for Irrigation and Landscape Lighting, Maximum 30 Volts, Installed with Type UF Cable or Raceway
All locations not specified below	24	6	18	12	6
In trench below 2-inch thick concrete	18	6	12	6	6
Under a building	0 (in raceway)	0	0	0 (in raceway)	0 (in raceway)
Under 4-inch thick concrete	18	4	4	6 (direct burial) 4 (in raceway)	6 (direct burial) 4 (in raceway)
Under street, driveways, and parking lots	24	24	24	24	24
One- and two-family driveways or outdoor parking area	18	18	18	12	18

INDOOR SPAS AND HYDROMASSAGE BATHTUBS

At least one receptacle shall be located a minimum of 5 feet from and not more than 10 feet from the inside wall of the spa or hot tub. Receptacles located within 10 feet of the inside walls of a spa or hot tub shall be protected by a ground-fault circuit-interrupter. Receptacles that provide power shall be ground-fault circuit-interrupter protected.

Wall switches shall be located at least 5 feet measured horizontally, from the inside walls of the spa or hot tub.

PLUMBING REQUIREMENTS

Each plumbing fixture shall be provided with an adequate supply of potable running water piped in an approved manner, so arranged as to flush and keep it in a clean and sanitary condition without danger of back flow or cross-connection. All plumbing fixtures shall be provided with hot and cold running water except water closets (toilets) shall be provided with cold water only.

EQUIPMENT

All plumbing appliances, equipment, and fixtures shall be listed by an approved testing agency (e.g. Underwriters Laboratories-UL, International Association of Plumbing and Mechanical Officials - IAPMO, etc.) or approved by the Chief Building Official. All equipment shall also comply with the energy efficiency standards of the State of California Energy Commission.

INSTALLATION STANDARDS

All plumbing appliances, equipment, and fixtures shall be installed and located as specified in the manufacturer's installation standards.

WATER SUPPLY

Materials used for plumbing systems shall be as follows:

WATER SUPPLY PIPING MATERIALS	
Location	Allowable Materials
Inside of a building	brass, copper (Type L or M), cast iron, galvanized malleable iron, galvanized steel, PVC, or PEX
Outside of a building	PVC, CPVC, brass, copper (type L or M), galvanized malleable iron, or galvanized steel

When plastic piping is used for the main water line or interior water distribution pipes, a label shall be permanently fastened to the main electrical meter panel stating, "This structure has a nonmetallic water service/water distribution lines."

Underground water lines shall be buried a minimum of 12 inches below grade.

All materials used in the water supply system within the building shall be of like materials, except valves and similar devices. Following are acceptable methods of joining dissimilar materials:

- Joints from copper tubing to threaded pipe shall be made by the use of brass adapter fittings.
- Dielectric unions shall be used at all point of connection where dissimilar metals are used. Listed clamps and bonding jumpers shall be installed at all such connections.
- When connecting plastic pipe to other types of piping, approved types of fittings and adapters designed for the specific transition shall be used.
- When dielectric fittings are used to join dissimilar metals, listed clamps and a bonding jumper shall be installed at such connections.

WATER HEATERS

Seismic Bracing

Water heaters require two seismic straps; one located within the top 1/3 of the water heater unit and one at the bottom 1/3. The bottom strap must be located at least 4 inches away from the water heater controls.

There are a number of seismic strap kits that are available commercially, however, metal plumbers tape can be used if it completely encircles the water heater and is then attached to a structural framing member at each end. Any platform supporting the water heater must be secured to the structure or the slab. Additional blocking at the water heater may be required to resist horizontal displacement.

Venting

The vent and the water heater must maintain clearance from combustible materials such as wall framing or roofing. Generally this clearance is required to be 6 inches when the vent material is single-walled and 1 inch when the vent material is double-walled, but check the manufacturers listing on the materials. The vent shall terminate a minimum 6 inches above the roof through flashing at the roof and terminate in a listed and approved vent cap. Vents may require additional supports depending on the material and design.

All single-walled vents and single-walled to double-walled vent joints shall be secured with a minimum of three sheet metal screws, rivets or similar positive connection.

Pressure/Temperature Valve

All water heaters have a pressure/temperature (P/T) relief valve. The valve shall be drained to the exterior and terminate toward the ground maintaining between 6 inches and 24 inches of clearance from the ground and pointing downward. The diameter of the valve opening (generally $\frac{3}{4}$ inch) must be maintained to the termination of the drain. Check the manufacturer's requirements. Relief valve drains shall not terminate in a building's crawl space. No part of such drain pipe shall be trapped or subject to freezing. When approved by the Chief Building Official, such drain may terminate at other locations (i.e. laundry tub, floor sink, or floor drain). No

part of such drain shall be trapped and the terminal end of the drain shall not be threaded.

Located in an Attic or Closet with Wood Framing Underneath

If located in an attic or furred space (i.e. closet) where leaking could cause damage to underlying wood framing, the water heater must be set in a pan constructed of water tight corrosion resistant material. The pan must be fitted with a minimum $\frac{3}{4}$ inch drain that drains to an approved location. The P/T line is not allowed to terminate at this pan or be connected to it.

When located in attic, the water heater shall be accessible through an opening and passageway at least large as the largest component of the appliance, and not less than 22 inches by 30 inches. Where the height of passageway is less than 6 feet the distance from the passageway access to appliance shall not exceed 20 feet measured along the centerline of the passageway. The passageway shall be unobstructed and shall have solid flooring not less than 24 inches. A level working platform not less than 30 inches by 30 inches shall be provided in front of the service side of the appliance. A permanent 120-volt receptacle outlet and lighting fixture shall be installed near the appliance. The switch controlling the lighting fixture shall be located at the entrance to the passageway.

Located in a Garage

Appliances generating a glow, spark or flame capable of igniting flammable vapors may be installed in a garage provided the pilots and burners or heating elements and switches are at 18 inches above floor level (unless the unit is listed as flammable vapor ignition resistant). If subject to vehicular damage, adequate barriers must be installed (e.g. 4 inch diameter steel post installed in a 1 foot diameter by 2 foot deep footing).

Located in a Bedroom, Bathroom, or Closet

Water heaters shall be permitted to be installed in a bedroom, bathroom, or closet when provided with a listed self-closing, gasketed door and all combustion air shall be obtained from outdoors. Closets shall not be used for any other purpose.

Combustion Air

Combustion air must be maintained per California Plumbing Code. When the appliance is located in an unconfined space (e.g. garage) the combustion air can be used from that area. When located in a closet, combustion air must be provided at a minimum of two openings (one at the top and one at the bottom) sized at 100 square inches each.

Sediment Trap

A sediment trap shall be installed on the gas line as close to inlet of the equipment as practical. The following diagram illustrates sediment trap installation details:

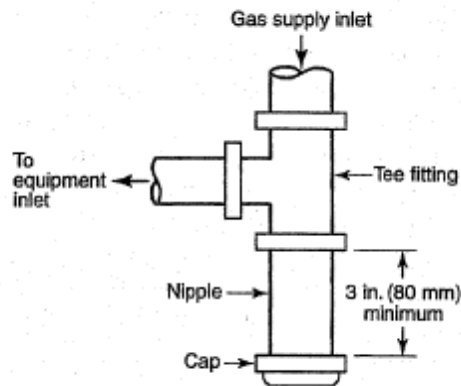

Tankless Water Heaters

Tankless water heaters shall be listed by an approved testing agency (UL, UPC, etc.) and be installed in accordance with the manufacturer's requirements. Category II stainless venting material and larger gas supply lines may be required based on the manufacturer's specifications/recommendations.

Tankless water heaters typically have a much higher BTU requirement than traditional tank water heaters. Therefore, the existing gas line may need to be replaced in order to supply the BTUs necessary based on the manufacturer's requirements.

PG&E requires a minimum horizontal clearance of 36 inches between the gas meter and a tankless water heater when located on the same wall.

IRRIGATION SPRINKLERS

Water supplies to lawn sprinkler systems shall be equipped with an approved vacuum breaker installed on the discharge side of each of the last valves. Vacuum breakers shall be installed at least 6 inches above the surrounding ground and above the highest sprinkler head so at no time will the vacuum breaker will be subject to back pressure to drainage. Irrigation pipes shall be installed a minimum of 12 inches below grade.

BATHTUBS AND SHOWERS

Any new or replaced mixing valve in a shower (including over a tub) shall be pressure balancing set at a maximum 120° F. Any new or replaced water-filler valve in bathtubs/whirlpools shall have a temperature limiting device set at a maximum of 120° F. The water heater thermostat cannot be used to meet these provisions.

Jacuzzis and spas shall have motor access, a dedicated circuit, and be UL listed. All metal cables, fittings, piping, or other metal surfaces, within 5 feet of the inside wall of the Jacuzzi/spa shall be properly bonded.

BUILDING SEWERS/DRAINAGE SYSTEM

Materials used for sewer systems shall be as follows for one- and two-story residential dwelling units:

SEWER/DRAINAGE PIPING MATERIALS	
Location	Allowable Materials
Inside of a building	cast iron, clay, lead, or copper type DWV. Schedule 40 DWV ABS/PVC may be used in residential building with a maximum of 2 stories.
Outside of a building	cast iron, clay, lead, copper type DWV, or schedule 40 DWV ABS/PVC

All piping of the building sewer which connects a draining system to the public or private sewer must be of approved material and sizing. Sewers are to be kept in proper alignment and installed with a minimum slope of 2% or 1/4 inch per foot of pipe.

Clean outs shall be installed with 2 feet of the exterior of the building, at the property line, and at each aggregate horizontal change in direction exceeding 135°.

Traps

An approved type water seal must be installed immediately on the discharge side of every plumbing fixture, except for those fixtures having an integral trap (toilet), to prevent the back passage of air without materially affecting the flow of sewage or waste water through the fixture.

Venting

An atmospheric vent of acceptable size and material is required on the discharge side of each and every fixture trap. Vents provide airflow to protect trap seal from siphonage and back pressure.

Island sinks have special venting requirements as illustrated in the following diagram:

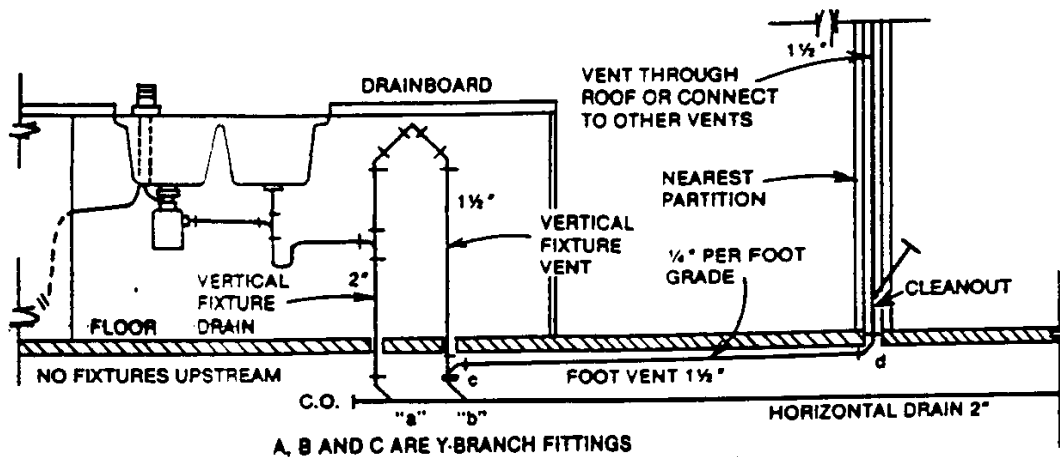

GAS PIPING

Gas piping material shall be of wrought iron or steel (galvanized or black), yellow brass, or copper types K, L, or ACR.

Gas pipe shall not be installed below ground within the exterior boundaries of a building. Gas piping installed below ground outside of the exterior boundaries of any building shall be protected from corrosion by an approved coatings or wrapping material. Installation requirements for gas lines are listed in the following table:

INSTALLATION OF GAS PIPING (MINIMUM REQUIREMENTS)	
Location	Requirements
Installed outside, above ground	Installed a minimum 6 inches above grade secured to wall every 6 feet for 1/2 inch pipe and every 8 feet for 3/4 inch - 1 inch pipe.
Installed underground, beyond the exterior boundaries of any building	If metal piping is used, burial depth shall be 12 inches If plastic piping is used, burial depth shall be 18 inches

Valves used in connection with gas piping shall be of the approved types. An accessible shut-off valve of a type set forth in the paragraph above shall be installed in the fuel supply piping outside of each appliance and ahead of the union connection thereto, and in addition to any valve on the appliance. Shut-off valves shall be within 3 feet of the appliance. Shut-off valves may be located immediately adjacent to and inside or under an appliance when placed in an accessible and protected location so that such appliance may be removed without removal of the valve. Shut-off valves may be accessibly located inside wall heaters and wall furnaces listed for recessed installation where necessary maintenance can be performed without removal of the shut-off valve.

All gas outlets located in a barbecue or fireplace shall be controlled by an approved operating valve located in the same room and outside the hearth, but not more than 4 feet from such outlets. When piping on the discharge side of any such control valve is standard weight iron or galvanized steel, such piping may be imbedded in or surrounded by not less than 2 inches of concrete or masonry.

A gas appliance may be connected with an approved listed metal appliance connector under the following conditions:

- Listed metal appliance connectors shall have an overall length of not to exceed 3 feet except a range connector, which may not exceed 6 feet
- No part of such connector shall be concealed within or extended through any wall, floor or partition
- A listed accessible appliance connector valve not less than the nominal size of the connector shall be provided at the gas piping outlet immediately ahead of the connector
- All connectors shall be of such size to provide the total demand of the connected appliance
- Aluminum alloy connectors may be used only in interior locations where they shall not be in contact with masonry, plaster or insulation, or are not subject to repeated corrosive wettings

The connection of an indoor appliance with any type of gas hose is prohibited, except when used with laboratory or shop equipment or equipment that requires mobility during operation. Such connections shall have the shut-off or stopcock installed at the connection to the building piping. When gas hose is used, it shall be of the minimum practical, but not to exceed 6 feet, except for hand torches and special mobile equipment, and shall not extend from one room to another nor pass through any walls, partitions, ceilings, or floors. Under no circumstances shall gas hose be concealed from view or used in a concealed location. Only listed gas hose shall be used and only in accordance with its listing. Gas hose shall not be used where it is likely to be subject to excessive temperatures (above 125 degrees Fahrenheit) nor shall it be used as a substitute for a standard appliance connector.

Outdoor portable appliances may be connected with an approved outdoor hose connector not to exceed 15 feet in length provided it connects outdoors to approved gas piping including an approved valve at the inlet of the hose connector.

All gas piping shall be tested prior to connection to the gas system. The gas line is required to hold 3 pounds per square inch of air for 10 minutes. Test gauge shall have a scale not greater than 15 pounds.

SPACE HEATING AND COOLING REQUIREMENTS

EQUIPMENT

All heating and comfort cooling appliances shall be listed by an approved testing agency (e.g. Underwriters Laboratories-UL, International Association of Plumbing and Mechanical Officials - IAPMO, etc.) or approved by the Chief Building Official. All equipment shall also comply with the energy efficiency standards of the State of California Energy Commission.

INSTALLATION LOCATIONS

Heating and comfort cooling equipment shall be installed and located as specified in the manufacturer's installation standards. Wall heaters located in a bedroom, bathroom, or closet shall have a sealed combustion chamber and be directly vented to the exterior of the building.

Furnaces shall be installed in accordance with the manufacturer's installation requirements. When installed in a closet or alcove, the clear space around the furnace shall comply with the manufacturer's installation requirements.

COMBUSTION AIR

All fuel burning equipment shall be assured a sufficient supply of air for proper fuel combustion, ventilation and draft hood dilution installed with approved material and in such a manner to comply with the intent of the 2010 California Mechanical Code.

HEATING SYSTEM

Every dwelling unit and guest room shall be provided with heating facilities capable of maintaining a room temperature of 68 degrees Fahrenheit at a point 3 feet above the floor in all habitable rooms. Such facilities shall be installed and maintained in a safe condition.

No un-vented fuel-burning heater shall be permitted. All heating devices or appliances shall be of an approved type.

A sediment trap shall be installed on the gas line as close to inlet of the equipment as practical. The following diagram illustrates sediment trap installation details:

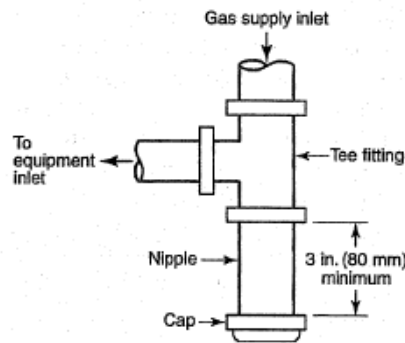

AIR CONDITIONING SYSTEM

The condenser unit shall be located and secured to a 3-inch thick slab or approved platform. The condensate line shall drain to a landscaped area or to the sanitary sewer line.

Insulation on the suction line (cooling refrigerant line) shall be protected from physical damage or ultraviolet deterioration by an aluminum or metal shroud, paint, plastic cover, or ultraviolet resistant tape.

The exterior air conditioning condenser units shall meet the minimum setback requirements for the zoning district. Additionally, noise generated by condenser, regardless of its location, cannot exceed 65 decibels during the day, or 50 decibels at night as measured from any property line.

Setbacks

The condenser unit shall meet the zoning district setbacks for the property. For all residentially zoned properties, the minimum rear yard setback is 10 feet. For properties in the R-0, R-1.5 and R-2 Zoning Districts, the minimum side yard setback is 4 feet. All other residential zoning districts require a 6 feet minimum side yard setback. Corner lots must have a 9 feet setback along the longer street frontage.

Noise

Noise shall not exceed 50 dBA during the hours of 10:00 p.m. and 7:00 a.m. or 60 dBA during 7:00 a.m. and 10:00 p.m. at any point on adjacent residentially zoned property.

Screening

All air conditioning units must be screened on all four sides. In most cases, air conditioning units located in private yards meet this requirement. If the proposed air conditioning unit is located on the roof, on a corner lot between the fence and the street, or in private homeowner's association area.

VENTING OF APPLIANCES

Every vented appliance shall be connected to an approved venting system designed and constructed as to develop a positive flow adequate to convey all combustion products to the outside atmosphere.

DUCTS

Every duct and plenum which is a portion of any comfort heating, comfort cooling system shall be of galvanized sheet 30 gage if 14 inches or less and 28 gage if over 14 inches. All seams shall be made substantially airtight. Non-metallic duct system shall be of approved type for the use intended and identified by a label of other suitable identification.

MEANS OF DISCONNECT

An approved, independent means of disconnect for the electrical supply to each piece of equipment shall be provided in sight (but not more than 50 feet away) of the equipment served when the supply voltage exceeds 50 volts. The main electrical panel shall be labeled with the circuit for the new equipment.

SERVICE RECEPTACLE

Provide a 15- or 20 amp receptacle at an accessible location within 25 feet of the condenser unit. If located outside, the receptacle shall be GFCI protected and in a weatherproof cover (bubble cover). The service receptacle shall not be connected on the load side of the required means of disconnect.

ILLUMINATION

Permanent switch controlled lighting shall be installed for maintenance of equipment and shall be accessible. Such lighting shall provide sufficient illumination to safely approach the equipment and perform the tasks for which access is provided. Control of the lighting shall be provided at the access entrance.

EQUIPMENT LOCATED IN A GARAGE

Appliances generating a glow, spark, or flame capable of igniting flammable vapors may be installed in a garage provided the pilots and burners or heating elements and switches are at least 18 inches above floor level.

Exception: Sealed combustion system appliances may be installed at floor level.

If subject to vehicular damage, adequate barriers must be installed (e.g. 4 inch diameter steel post installed in a 1 foot diameter by 2 foot deep footing).

EQUIPMENT LOCATED IN AN ATTIC

Furnaces located in an attic area shall comply with the diagram below. Additionally, if the attic and roof is conventionally framed, ceiling joist under the location of the FAU unit shall be doubled with a minimum 2X6 joists. If the attic and roof framing is a pre-fabricated engineered truss system, an engineering report (wet stamped and signed by a licensed engineer) shall be submitted for review and approval prior to issuance of a building permit.

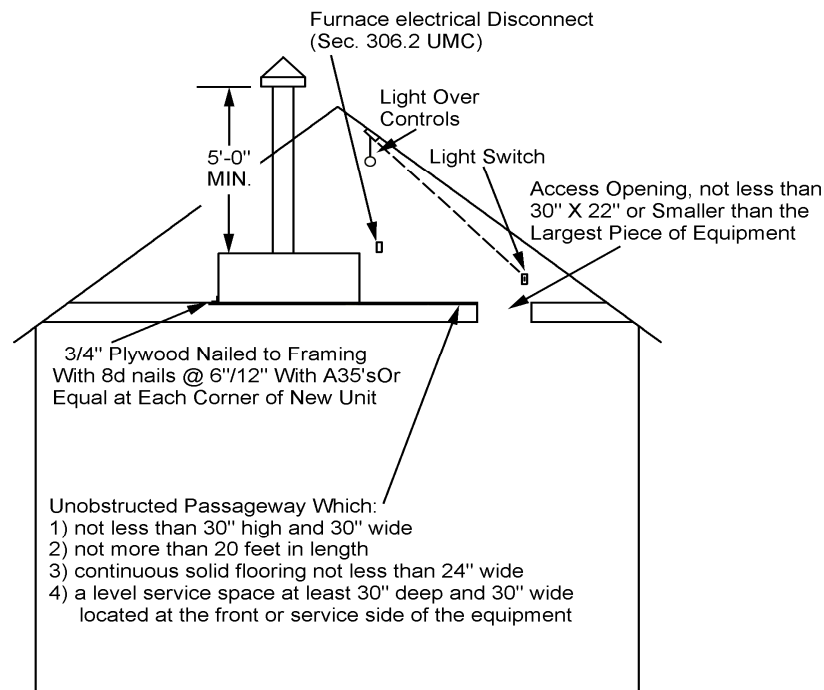

ENERGY CONSERVATION REQUIREMENTS

The State of California Energy Commission requires all residential construction (including new buildings and additions/remodels to existing buildings) to meet minimum energy efficiency. These energy efficiency standards are commonly referred to as "Title 24." Following is a synopsis of these standards for single family homes. For further information, refer to www.energy.ca.gov/title24 or contact an energy consultant.

Energy compliance documentation is required when submitting plans for new construction or an addition to an existing home. Completion of the documentation ensures that the construction, as planned, will comply with the State of California

Energy Efficiency Standards. Compliance with these standards at the construction phase is ensured by the contractor completing an Installation Certificate or Insulation Certificate stating that all equipment was installed according to the approved plans.

When remodeling an existing residential building where no new square footage is added, specific forms or documentation is not be required; however, minimum mandatory features must still be met. Refer to the Mandatory Measures section below for specific information.

The Energy Commission offers two methods of ensuring new construction and additions meet the energy efficiency standards; a prescriptive package or a performance method. The prescriptive package provides a standardized list of requirements for energy efficiency measures. The required documentation is typically completed by the project designer or architect. When these prescriptive measures are not met, a computer-based performance method can be used to determine compliance with the energy standards. The performance method is typically done by an energy consultant.

The following describes the applicable Title 24 energy efficiency requirements for various types of residential construction/alterations:

ENERGY EFFICIENCY REQUIREMENTS FOR RESIDENTIAL CONSTRUCTION/ALTERATIONS	
Type of Construction/Alteration	Title 24 Standards
Interior Alternation/Remodel (no additional square footage)	Mandatory Measures
Addition to Existing Buildings and New Construction	Mandatory Measures and either the Prescriptive Package or Performance Standards

MANDATORY MEASURES

The following mandatory measures are required for all interior alternations/remodels, additions to existing buildings, and new construction. These are minimum requirements and more efficient standards may be required with the computer Performance Standards method, which is typically completed by an energy consultant.

Building Insulation

The following table shows the minimum insulation ratings allowed:

MINIMUM INSULATION RATINGS	
Locations	Insulation Rating
Ceiling (wood framed)	R-30
Walls (wood framed)	R-13
Raised floors	R-19

Water Heater Tank Insulation

Water heater tanks shall be externally insulated with an R-12 wrap unless the energy factor rating of the water heater unit exceeds the Federal minimum standards (this information is on the manufacturer informational label on the unit).

Pipe Insulation

Insulation shall be protected from damage, including that due to sunlight, moisture, equipment maintenance, and wind including but not limited to the following:

- Insulation exposed to weather shall be suitable for outdoor service; e.g., protected by aluminum, sheet metal, painted canvas, or plastic cover. Cellular foam insulation shall be protected as above or painted with a coating that is water retardant and provided shielding from solar radiation that can cause degradation of material.
- Insulation covering chilled water and refrigerant suction piping located outside the conditioned space shall include a vapor retardant located outside the insulation (unless the insulation is inherently vapor retardant), all penetrations and joints of which shall be sealed.

Pipe insulation is required in the following locations:

- The first 5 feet of hot and cold water pipes from the storage tank.
- All piping with a diameter of $\frac{3}{4}$ inch or larger.
- All piping associated with a recirculating system regardless of the pipe diameter.
- Piping from the heating source to a storage tank or between tanks.
- Piping buried below grade.
- All hot water pipes from the heating source to the kitchen fixtures.

PIPE INSULATION REQUIREMENTS MINIMUM R-VALUE	
Hot or Cold Piping Size	Insulation Thickness Required for Pipe Diameter Less than or Equal to 2 inches
< 1 inch	1.0 inch
1 inch to <4 inches	1.5 inch

Windows, Skylights, and Exterior Doors

Manufactured exterior doors and windows/skylights (window) products must be certified by the California Energy Commission. The minimum standards for new windows, skylights, or exterior doors are a maximum U-factor of 0.58 and Solar Heat Gain Coefficient (SHGC) of 0.58. This certification will be shown as a label on the window, skylight, or exterior door. The label shall not be removed before inspection.

Joints and Other Openings

The following openings in the building envelope must be caulked, gasketed, weather-stripped or otherwise sealed:

- Exterior joints around window and door frames, between wall sole plates, floors, exterior panels and all siding materials

- Opening for plumbing, electricity, and gas lines in exterior walls, ceilings, and floors
- All other such openings in the building envelop

Fireplaces, Decorative Gas Appliances, and Gas Logs

Because conditioned air can escape through a fireplace chimney, fireplace efficiency can be greatly improved through proper air control. Installation of a factory-built or masonry fireplace shall include:

- Closable metal or glass doors covering the entire opening of the firebox which can be closed when the fire is burning.
- Combustion air intake to draw air from the outside of the building directly into the firebox. This intake must be at least 6 square inches in area and be equipped with a readily accessible, operable and tight-fitting damper. Outside combustion air intakes are not required if the fireplace is installed over a concrete slab and will not be located on an exterior wall.
- A flue damper with a readily accessible control.

Space Conditioning, Water Heating, and Plumbing System

The design and installation of a building's space conditioning, water-heating and plumbing systems have a significant impact on the building's energy consumption. In view of this, the standards set a number of minimum requirements for these systems.

Only HVAC (heating, ventilating, and air conditioning), water heating, and plumbing system equipment certified by the manufacturer as complying with applicable Appliance Efficiency Standard may be installed.

This certification will be shown on the label on the equipment. The label shall not be removed before inspection. A certificate of compliance with the Appliance Efficiency Standards must be posted at the building site when any equipment subject to the standards is installed.

Setback Thermostats

All heating and/or cooling systems must have an automatic setback thermostat with a clock mechanism. The setback thermostat or mechanism is required to shut the system off during periods of non-use and allows the building occupant to automatically setback the thermostat to set points for at least four periods within 24 hours.

Pilot Lights

Continuously burning pilot lights are not permitted on any of the following equipment:

- Fan type central furnaces.
- Household cooking appliances, except cooking appliances without an electrical supply and which each pilot consumes less than 150 Btu/hr.
- Pool heaters or spa heaters.
- Fireplaces, decorative gas appliances, and gas logs.

Lighting

High Efficiency Lighting Fixtures

High efficiency lighting fixtures for residential lighting shall contain only high efficiency lamps and shall not contain a medium screw base socket. Ballasts for fluorescent lamps rated 13 watts or greater shall be electronic and shall have an output frequency not less than 20 kHz.

Any low efficiency lighting shall be on separate switches from the high efficiency lighting.

The following table lists the minimum lumens per watt rating for lighting in order to qualify as high efficiency:

HIGH EFFICIENCY LAMP REQUIREMENTS	
Lamp Power Rating	Minimum Lamp Efficiency
5 or less	30 lumens per watt
Over 5 to 15 watts	40 lumens per watt
over 15 watts to 40 watts	50 lumens per watt
over 40 watts	60 lumens per watt

A listing of approved high efficiency lighting fixtures is available on-line at: <http://www.appliances.energy.ca.gov/QuickSearch1024.aspx>

Lighting in Kitchens

Permanently installed lighting fixtures in kitchens shall have a total rated wattage shall be high efficiency lighting fixtures. However, a maximum of 50 percent of the total rated wattage (manufacturer's maximum wattage) may be low efficiency lighting.

When calculating the total rated wattage of permanently installed lighting, include lighting in areas adjacent to the kitchen if they are controlled by the same switch as the kitchen lighting.

Permanently installed lighting that is located within cabinetry shall be designed so that the lighting fixtures use a maximum of 20 watts per lineal foot of illuminated cabinetry.

Lighting in Bathrooms

Bathrooms shall have a minimum of one high efficiency fixture permanently installed. Any additional lighting fixtures installed that are not high efficiency shall be controlled with a vacancy sensor switch that requires a manual on activation (does not automatically turn on) and automatically turns off within 30 minutes after the room is vacated.

Lighting in Garages, Laundry Rooms, and Utility Rooms

Permanently installed lighting fixtures in garages, laundry rooms, and utility rooms shall be high efficiency lighting fixtures or controlled by a vacancy sensor switch. The vacancy sensor switch requires a manual on activation (does not automatically turn on) and automatically turns off within 30 minutes after the room is vacated.

Lighting other than in Kitchens, Bathrooms, Garages, Laundry Rooms, and Utility Rooms

Permanently installed lighting fixtures located in rooms other than kitchens, bathrooms, garages, laundry rooms, and utility rooms shall be high efficiency lighting fixtures or shall be controlled by a dimmer switch or vacancy sensor switch. The vacancy sensor switch requires a manual on activation (does not automatically turn on) and automatically turns off within 30 minutes after the room is vacated.

Recessed Luminaries in Ceilings

Lighting fixtures recessed into ceilings shall be approved for zero clearance insulation cover (IC) and include a label certifying air tight (AT), and shall be sealed with a gasket or caulk between the housing and ceiling.

Outdoor Lighting

Lighting fixtures providing outdoor lighting and permanently attached to a residential building or to other buildings on the same lot shall be high efficiency lighting fixtures or shall be controlled by a motion sensor with integral photo control.

Air-Distribution System Ducts and Fans

Portions of supply-air and return-air ducts and plenums shall either be insulated to a minimum installed level of R-4.2 or be enclosed entirely in conditioned space.

Connections of metal ducts and the inner core of flexible ducts shall be mechanically fastened. Openings shall be sealed with mastic, tape, or other duct-closure system that meets the applicable requirements of UL 181, UL 181A or UL 181B or aerosol sealant that meets the requirements of UL 723. If mastic or tape is used to seal openings greater than 1/4 inch, the combination of mastic and either mesh or tape shall be used. Products that meet the Underwriters Laboratories, Inc. (UL) standards will display such sticker on the product and shall be installed in accordance with the manufacturer's installation requirements.

All fan systems that exhaust air from the building to the outside, regardless of capacity, must be provided with back draft or automatic dampers to prevent air leakage.

Building cavities, support platforms for air handlers, and plenums defined or constructed with materials other than sealed sheet metal, duct board or flexible duct shall not be used for conveying conditioned air. Building cavities and support platforms may contain ducts. Ducts installed in cavities and support platforms shall not be compressed to cause reductions in the cross-sectional area of the ducts.

Protection of Insulation

Insulation shall be protected from damage, including that due to sunlight, moisture, equipment maintenance, and wind but not limited to the following:

- Insulation exposed to weather shall be suitable for outdoor service (e.g., protected by aluminum, sheet metal, painted canvas, or plastic cover).
- Cellular foam insulation shall be protected as above or painted with a coating that is water retardant and provides shielding from solar radiation that can cause degradation of the material.

Duct System Sealing and Leakage Testing

When space conditioning systems utilize forced air duct systems to supply conditioned air to an occupiable space, the ducts shall be sealed, as confirmed through field verification and diagnostic testing. The total leakage of the duct system shall not exceed 6 percent.

Whenever an existing furnace is replaced, new or replacement air conditioning is installed, ducts are replaced, or 40 feet of new ducts added, a duct leakage test is also required. The total leakage of the duct system shall not exceed 15 percent.

The duct air leakage tests are performed by a HERS rater. A listing of certified HERS raters can be found at: <http://www.energy.ca.gov/HERS/providers.html>

NEW CONSTRUCTION AND ADDITIONS TO EXISTING BUILDINGS

New construction and additions to existing residential buildings shall meet the requirements Mandatory Features as described above and either the Prescriptive Package or the Performance Standards as described below.

The Prescriptive Package is a standard list of energy efficiency requirements for additions and new construction. The benefit of the Prescriptive Package is that the required compliance documentation can typically be completed by a residential designer or homeowner and may not require the use of an energy consultant. In order to use the Prescriptive Package, all of the requirements must be met without deviation. If the Prescriptive Package requirements are not met, compliance with the energy efficiency standards can be demonstrated by using the Performance Standards. This is typically completed by an energy consultant.

Prescriptive Package

While Title 24 offers various Prescriptive Packages, the package most commonly used in Sunnyvale is Package A and contains the following requirements:

PRESCRIPTIVE PACKAGE A	
Feature or Equipment	Minimum Standards
Insulation	Ceiling: R-30 Wall: R-15+4 or R-13+5 Raised-floor: R-19
Radiant Barrier	The required radiant barrier is a highly reflective, low emitting material installed at the underside surface of the roof deck and the inside surface of the gable ends or other exterior vertical surfaces in attics to reduce solar heat gain into the attic.
Windows/ skylights	Total maximum area is 20% of floor area with no more than 5% facing west. Maximum U-factor: 0.32 Maximum Solar Heat Gain Coefficient (SHGC): 0.25
Space Heating and Space Cooling Equipment	Gas furnaces shall be approved by the California Energy Commission.
Water Heating Systems	A single gas or propane tank storage type water heater that has a maximum input of 75,000 Btu per hour that is externally insulated with an R-12 wrap unless the energy factor rating of the water heater unit exceeds the Federal minimum standards. Or, a single gas or propane instantaneous, tankless water heater with a maximum input of 200,000 Btu per hour. For recirculation distribution systems, only Demand Recirculation Systems with manual control pumps shall be used.

Performance Standard

When the requirements of the Prescriptive Package, as noted above, are not met, the Performance Standard method can be used to show compliance with the Title 24 energy requirements. The Performance Standard method uses an approved computer program to weigh and balance areas which do not meet the Prescriptive Package requirements with other areas that may be enhanced beyond the minimum requirements. The Performance Standards are typically completed by an energy consultant.