

Stanford | ENGINEERING



2014-2015

HANDBOOK

for

Undergraduate

Engineering

Programs

Online at

<http://ughb.stanford.edu>

School of Engineering Contacts

Undergraduate Student Services & Program Directors

Chemical Engineering

Student Services

Dixon, Pamela, Shriram 129, prdixon@stanford.edu

Prof Spakowitz, Andy – Shriram 129 aspakow@Stanford.edu

Civil Engineering

Student Services

Jill Filice – Y2E2 Bldg Rm 316, filice@stanford.edu

Prof Billington, Sarah – 285A Y2E2 Bldg, billington@stanford.edu

Computer Science

Student Services

Hutchin, Meredith – Gates 193, hutchin@cs.stanford.edu

Prof Sahami, Mehran – Gates 180, sahami@cs.stanford.edu

Electrical Engineering

Student Services

Duncan, Amy – Packard 177, aduncan@stanford.edu

Prof Dutton, Robert – Allen 333X, rdutton@stanford.edu

Engineering Subplan Majors:

Aeronautics & Astronautics

Student Services

Ferguson, Patrick – Durand 250, patrickf@stanford.edu

Prof Pavone, Marco – Durand 261, pavone@stanford.edu

Architectural Design

Student Services

Jill Filice – Y2E2 Bldg Rm 316, filice@stanford.edu

Barton, John – Y2E2 Bldg Rm 267, jhbarton@stanford.edu

Atmosphere/Energy

Student Services

Jill Filice – Y2E2 Bldg Rm 316, filice@stanford.edu

Prof Jacobson, Mark – Y2E2 Rm 397, jacobson@stanford.edu

Bioengineering

Student Services

Hankes, Teri – Shriram 119, thanks@stanford.edu

Prof Deisseroth, Karl – Clark W083, deissero@stanford.edu

Biomechanical Engineering

Student Services

Stangl, Indrani – Bldg 530-125, indrani@stanford.edu

Guerriero, Kelly – Bldg 530-125, Kellybg@stanford.edu

Prof Levenston, Marc – Durand 233, levenston@stanford.edu

Biomedical Computation

Student Services

Lazar, Darlene – 135 Huang, dlazar@stanford.edu

Prof Altman, Russ, Clark S242, russ.altman@stanford.edu

Dr Kaushal, Amit – akaushal@stanford.edu

Engineering Physics

Student Services

Lazar, Darlene – 135 Huang, dlazar@stanford.edu

Prof Burchat, Patricia – Varian Physics 158, burchat@stanford.edu

Prof Cappelli, Mark – Bldg 520-520D, cap@stanford.edu

Product Design

Student Services

Stangl, Indrani – Bldg 530-125, indrani@stanford.edu

Guerriero, Kelly – Bldg 530-125, kellybg@stanford.edu

Prof Burnett, William – Bldg 550-137, wburnett@stanford.edu

Environmental Engineering

Student Services

Jill Filice – Y2E2 Bldg Rm 316, filice@stanford.edu

Prof Billington, Sarah – 285A Y2E2, billington@stanford.edu

Individually Designed Majors

Student Services

Lazar, Darlene – 135 Huang, dlazar@stanford.edu

Prof Osgood, Brad – 135 Huang, osgood@stanford.edu

Management Science and Engineering

Student Services

Cottle, Lori Huang, Suite 114, lcottle@stanford.edu

Prof Shachter, Ross – Huang 337, shachter@stanford.edu

Materials Science and Engineering

Student Services

Verplanke, Fi – 115 Durand, Verplanke@stanford.edu

Gribble, Kevin – 111A Durand, Kgribble@stanford.edu

Prof Sinclair, Robert – 113 Durand, bobsinc@stanford.edu

Mechanical Engineering

Student Services

Stangl, Indrani – Bldg 530-125, indrani@stanford.edu

Guerriero, Kelly – Bldg 530-125, Kellybg@stanford.edu

Prof Sheppard, Sheri – Bldg 550-119, sheppard@stanford.edu

Engineering Diversity Programs

Dr. Lozano, Noé – 135 Huang, noe@stanford.edu

Technical Communications Program

Reichard, Claude – 49 Huang, reichard@stanford.edu

Office of Student Affairs, 135 Huang Engineering Center

Senior Associate Dean:

Brad Osgood, osgood@stanford.edu

Associate Dean, Diversity Programs:

Noé Lozano, noe@stanford.edu

Assistant Dean for Graduate Student Affairs:

Sally Gressens, gressens@stanford.edu

Undergraduate Student Services:

Darlene Lazar, dlazar@stanford.edu

Graduate Student Services Assistant:

Denise Drewes, dadrewes@stanford.edu

Program Manager:

Escalera, Martha, marthae@stanford.edu

Administrative Assistant:

Nan Aoki, nanaoki@stanford.edu, 650-498-3890

Financial Administrator:

Martha Schmidhauser, marthas1@stanford.edu

Deans

Drell, Persis

Dean, School of Engineering, persis@stanford.edu

Osgood, Brad

Sr. Associate Dean for Student Affairs, osgood@stanford.edu

Widom, Jennifer

Sr. Assoc Dean for Faculty and Academic Affairs, widom@stanford.edu

Calvert, Scott

Sr. Associate Dean of Administration, scalvert@stanford.edu

Girod, Bernd

Sr. Associate Dean for Online Learning & Professional Development

Gressens, Sally

Assistant Dean for Graduate Student Affairs, gressens@stanford.edu

Lozano, Noé

Associate Dean for Engineering Diversity Programs, noe@stanford.edu

Chairs

Aeronautics and Astronautics

Farhat, Charbel, cfarhat@stanford.edu

Bioengineering

Pelc, Norbert, pelc@stanford.edu

Chemical Engineering

Shaqfeh, Eric, esgs@Stanford.edu

Civil and Environmental Engineering

Monismith, Stephen, monismith@stanford.edu

Computer Science

Aiken, Alex, chair@cs.stanford.edu

Electrical Engineering

El Gamal, Abbas, abbas@ee.stanford.edu

Management Science and Engineering

Glynn, Peter, glynn@stanford.edu

Materials Science and Engineer

McIntyre, Paul, pcm1@stanford.edu

Mechanical Engineering

Goodson, Kenneth, goodson@stanford.edu



STANFORD UNIVERSITY
SCHOOL OF ENGINEERING

2014-2015

**HANDBOOK FOR
UNDERGRADUATE ENGINEERING
PROGRAMS**

[HTTP://UGHB.STANFORD.EDU](http://ughb.stanford.edu)

This Handbook collects in one place information on undergraduate engineering programs at Stanford for 2014-2015. Here you will find details about school requirements and requirements for departments and programs, as well as instructions for declaring an engineering major, transferring engineering coursework from another school, petitioning for modifications of requirements, and the administrative steps to follow to graduate. You will also find descriptions of important opportunities and programs for engineering students, such as overseas studies, summer research fellowships, diversity programs, and career placement services.

There are always some changes from year to year and the Handbook is updated every summer before classes start in the fall. Since undergraduates come to the School of Engineering at different points in their Stanford careers, they may graduate using the requirements listed in any one Handbook that is published while they are undergraduates. All recent editions of the Handbook are available on the web at **<http://ughb.stanford.edu>**.

We hope that you will find the Handbook informative and useful, and we are interested in any suggestions you may have for improvements. If you have any questions about engineering degree requirements or about any of the information in the Handbook, please don't hesitate to contact your adviser or come see us in the School of Engineering's Office of Student Affairs, 135 Huang Engineering Center. You are always welcome.

Professor Brad Osgood
Professor of Electrical Engineering
Senior Associate Dean, School of Engineering

Revised August 2014 by Darlene Lazar

TABLE OF CONTENTS

1. FOR FRESHMEN AND SOPHOMORES	1
The Handbook Website is Central Station for UGs.....	1
Getting Started at Stanford.....	1
Planning your First (and Second) Year.....	2
Exploring Engineering.....	3
Mathematics Courses.....	6
Physics Courses.....	7
Chemistry Courses.....	8
Summing up.....	9
2. TYPES OF ENGINEERING MAJORS & ACCREDITATION	11
Departmental Majors.....	11
School Of Engineering Majors.....	12
Accreditation.....	13
3. COURSES APPROVED FOR SCHOOL OF ENGINEERING REQUIREMENTS	15
The Mathematics Requirement.....	15
The Science Requirement.....	17
The Technology in Society Requirement.....	18
The Engineering Fundamentals Requirement.....	19
The Experimentation Requirement.....	20
The Engineering Science and Engineering Design Requirement.....	20
4. POLICIES AND PROCEDURES	21
Policy on Academic Performance.....	21
Deviation Petitions and Substitutions.....	21
Transfer Credit.....	22
Advanced Placement Credits 2014-15.....	24
Graduation Procedures.....	25
5. PROGRAM DESCRIPTIONS AND REQUIREMENTS FOR ENGINEERING MAJORS	27
Undergraduate Program Sheets.....	27
Declaring an Engineering Major.....	29
Major Programs and their Requirements.....	30
AERONAUTICS AND ASTRONAUTICS	31
Requirements.....	31
AA Flowcharts (2).....	35
AA 4-Year Plans.....	37
Instructions for Declaring Major in Engineering: Aeronautics & Astronautics.....	40
AA Program Sheet.....	41
ARCHITECTURAL DESIGN	43
Requirements.....	43
Suggested Course Concentrations and Sequences.....	46
AD Flowchart.....	47
AD Four Year Plans.....	48
Plan 2.....	49
Instructions for Declaring Major in Engineering: Architectural Design (ENGR-BS).....	50

AD Program Sheet.....	51
ATMOSPHERE/ENERGY	53
Requirements	53
AE Energy Flowchart	56
AE Atmosphere Flowchart	57
AE 4-Year Plans (4).....	58
Instructions for Declaring Major in Engineering: Atmosphere/Energy (ENGR-BS)	62
AE Program Sheet	63
BIOENGINEERING	65
Research Experience for Undergraduates:.....	65
Components of BioE:	66
BioE Flowcharts	69
BioE -Year Plan 4.....	74
Instructions for Declaring Major in Engineering: Bioengineering (ENGR-BS).....	76
BioE Program Sheet	77
BIOMECHANICAL ENGINEERING.....	79
BME Flowchart	82
BME Four-Year Plan.....	84
Instructions for Declaring Major in Engineering: Biomechanical Engineering (ENGR-BS).....	88
BME Program Sheet.....	89
BIOMEDICAL COMPUTATION.....	91
Components of BMC:.....	91
Advising in BMC.....	93
Program Options.....	94
BMC Major Chart.....	96
BMC Flowchart	97
BMC Four Year Plans	98
Instructions for Declaring Major in Engineering: Biomedical Computation (ENGR-BS)	102
Program Sheets	103
CHEMICAL ENGINEERING.....	111
Instructions for finding out more about the Chemical Engineering Major	113
Requirements: Chemical Engineering Program	114
Chemical Engineering Flowcharts and Plans	116
Instructions for Declaring a Major in Chemical Engineering (CHEME-BS).....	130
Program Sheet: CHEME.....	131
CIVIL ENGINEERING.....	133
The Curriculum.....	134
Research Experience for Undergraduates.....	134
Exploring Civil Engineering as a Major	134
Requirements: 2014-15 Civil Engineering Major	135
CE with Specialty in Structures and Construction	136
CE with Specialty in Environmental and Water Studies	137
CE Flowchart	139
CE Four-Year Plans.....	140
Instructions for Declaring a Major in Civil Engineering.....	150
CE Program Sheet-Dry Track.....	151

CE Program Sheet-Wet Track	153
COMPUTER SCIENCE	155
Undergraduate Research Opportunities	156
Requirements	158
CS Flowchart	162
CS Four-Year Plans	163
Instructions for Declaring Major in Computer Science	172
CS Program Sheets	173
ELECTRICAL ENGINEERING	193
Research Experience for Undergraduates	201
Study Abroad Program	202
EE Flowchart	203
EE Four-Year Plans	204
Instructions for Declaring Major in Electrical Engineering	208
EE Program Sheet	209
ENGINEERING PHYSICS	211
Requirements	211
EPhys Flowchart	215
EPhys Four-Year Plans	216
Instructions for Declaring a Major in Engineering: Engineering Physics (ENGR-BS: EPHYS).....	224
ENVIRONMENTAL ENGINEERING	227
ENVIRONMENTAL SYSTEMS ENGINEERING	229
The Curriculum	229
A Comparison: Environmental Systems Engineering vs. Civil Engineering	230
Research Experience for Undergraduates	230
2014-15 EnvSE Major Requirements	231
ENVSE Flowchart	236
ENVSE Four-Year Plans	237
Instructions for Declaring Major in Environmental Systems Engineering	252
EnvE Program Sheet	253
INDIVIDUALLY DESIGNED MAJOR IN ENGINEERING	255
Instructions for Declaring an Individually Designed Major	258
IDMEN Program Sheet	259
MANAGEMENT SCIENCE AND ENGINEERING	261
Program Description	262
Research Experience for Undergraduates	264
MS&E Flowchart	267
MS&E 4-Year Plans (3).....	268
MS&E Program Sheet.....	273
MATERIALS SCIENCE AND ENGINEERING	275
Research Experience for Undergraduates	275
Requirements for Undergraduates in Materials Science and Engineering	277
MatSci Flowchart	282
MatSci 4-Year Plan.....	283
Instructions for Declaring Major in Materials Science and Engineering	284
MatSci Program Sheet	285

MECHANICAL ENGINEERING	287
Research Experience for Undergraduates.....	287
Professional Licensing.....	288
Requirements	289
ME Flowchart	292
ME Four-Year Plans (6)	293
ME Program Sheet.....	301
PRODUCT DESIGN	303
Requirements	303
PD Four-Year Plans (2)	305
Instructions for Declaring Major in Engineering: Product Design (ENGR-BS: PD).....	308
PD Program Sheet.....	309
6. MINORS AND HONORS PROGRAMS	311
Minor Programs.....	312
<i>Aeronautics and Astronautics Minor (ENGR-MINOR, AA)</i>	312
<i>Chemical Engineering Minor (CHEME-MINOR)</i>	313
<i>Civil Engineering Minor (CE-MINOR)</i>	313
<i>Computer Science Minor (CS-MINOR)</i>	314
<i>Electrical Engineering Minor (EE-MINOR)</i>	315
<i>Environmental Systems Engineering Minor (ENVSE-MINOR)</i>	316
<i>Management Science and Engineering Minor (MGTSC-MINOR)</i>	317
<i>Materials Science and Engineering Minor (MATSC-MINOR)</i>	318
<i>Mechanical Engineering Minor (ME-MINOR)</i>	318
Honors Programs	321
<i>Architectural Design</i>	321
<i>Atmosphere and Energy</i>	322
<i>Bioengineering</i>	322
<i>Biomechanical Engineering</i>	324
<i>Biomedical Computation</i>	325
<i>Chemical Engineering</i>	326
<i>Civil Engineering</i>	327
<i>Computer Science</i>	328
<i>Electrical Engineering</i>	328
<i>Engineering Physics</i>	329
<i>Environmental Engineering</i>	330
<i>Individually Designed Major in Engineering</i>	331
<i>Mechanical Engineering</i>	331
7. OTHER DEGREE PROGRAMS	333
Alternative Bachelor’s Degrees.....	333
Coterminal Degree Programs	333
8. SPECIAL PROGRAMS AND ORGANIZATIONS	335
Engineering Diversity Programs (EDP)	335
Technical Communications Program	336
Stanford Technology Ventures Program	337
Tutoring & Academic Support	338
Engineers and Overseas Studies	338
<i>Global Engineering Programs</i>	338
Bing Overseas Studies Program (BOSP)	339
<i>Australia</i>	340
<i>Beijing</i>	341
<i>Berlin</i>	341

<i>Cape Town</i>	342
<i>Florence</i>	343
<i>Kyoto</i>	344
<i>Madrid</i>	345
<i>Oxford</i>	345
<i>Paris</i>	346
<i>Santiago</i>	346
<i>Overseas Seminars</i>	347
<i>Other BOSP Programs and Resources</i>	347
Research Experience for Undergraduates	348
Student Engineering Societies	348
<i>Tau Beta Pi</i>	348
<i>Institute of Electrical and Electronics Engineers</i>	349
<i>Business Association of Stanford Engineering Students (BASES)</i>	349
<i>School of Engineering Student Diversity Groups</i>	350
<i>Stanford Solar Car Project</i>	350
<i>Stanford Student Biodesign (SSB)</i>	350
<i>Stanford Solar Wind and Energy Project (SWEP)</i>	350
9. SUMMER EMPLOYMENT AND CAREER PLANNING	351
Career Development Center.....	351
Overseas Resource Center	352
Fundamentals of Engineering Exam.....	354
10. FORMS	355
11. INFORMATION FOR ADVISORS	357

1. FOR FRESHMEN AND SOPHOMORES

Just as it is for students at any university at the beginning of the year, your first weeks here will certainly be exciting, and may be overwhelming. For freshmen everything is new, and during orientation and as the school year begins you will be immersed in a constant stream of academic information together with many bits and pieces of Stanford culture. For sophomores, as you begin to move toward study that is more specialized, there will still be much for you to discover. This Handbook can help to inform your academic choices and provide some perspective on the School of Engineering within Stanford University.

THE HANDBOOK WEBSITE IS CENTRAL STATION FOR UGS

The UGHB website at ughb.stanford.edu offers the latest updates on course offerings, events, scholarships, and other of-the-moment items and links of interest to those in (or contemplating) an engineering major. Here is some of what you will find on the site: Links to all the major programs; Handbook pdfs; Program Sheets (for major and minor programs); Petitions; 4-Year plans; opportunities for research, jobs, and other items of interest; Approved Course Lists; Graduation Guidelines; and a page just for Prospective Stanford engineers.

Email is Not Dead! Urgent and/or helpful messages will come via Stanford email from the staff of your major department or from Darlene Lazar in the Office of Student Affairs – watch for these.

GETTING STARTED AT STANFORD

One of the great advantages of Stanford as an undergraduate institution is the tremendous breadth of excellence that the university offers. Some universities are strong in particular disciplines, while less so in others. The faculty and students we have been able to attract over the years have placed Stanford in the wonderful and exceptional position of being strong across the board. In engineering, as well as in the sciences, humanities, and social sciences, surveys conducted by the National Academies and other professional organizations that seek to assess the strength of academic programs all attest to the eminence of Stanford in education and research.

As an undergraduate, you should take the time to explore that wealth of academic excellence. Committing yourself prematurely to one discipline or coming in with too-firmly fixed ideas of

exactly where you are going can take away from your chances to discover what Stanford has to offer, and to take advantage of all its diversity. Stanford encourages academic exploration by not requiring you to make a commitment up front; at many universities, students are asked to declare their intended major as part of the application process, particularly if they are interested in engineering. Not so at Stanford. Here, you need not declare a major until preparing to sign up for classes for junior year. You have the time to explore different possibilities before settling on a major.

At the same time, the flexibility that Stanford offers does not mean that you, as a prospective student of engineering, can afford to spend your first two years completely away from the techie side of things. Engineering majors typically require more courses and units than majors in other parts of the university. Technical courses, moreover, tend to be cumulative, in the sense that more advanced courses draw heavily on the material presented in the introductory courses that precede them. In engineering, you need to strike a balance between taking advantage of the freedom to explore and making sure that you are getting a reasonable start on an engineering curriculum.

PLANNING YOUR FIRST (AND SECOND) YEAR

The best strategy is to avoid the extremes. A first-year schedule that includes *no* mathematics, science, or engineering will make it very difficult to complete an engineering major in four years. Conversely, it is surely a recipe for disaster to insist on packing your first year with three quarters each of calculus, physics, and chemistry along with the mandatory Thinking Matters and Program in Writing and Rhetoric (PWR) classes. There is too much work in each of those courses to take them all at the same time, particularly before you've had a chance to acclimate to Stanford's intensity and rapid pace. You should seek an appropriate balance for your studies.

The **Thinking Matters** courses are open exclusively to freshmen and explore important problems or fundamental questions. They offer you individualized attention in building the intellectual skills you will need to succeed in the university. Every Stanford student must take one Thinking Matters course, but you are open to enroll in more than one. After your freshman year you will not be able to take these courses – seize the moment!

All Stanford students also must take courses in the **PWR** program designed to build your communicative skills in writing and other media. Normally students enroll in PWR 1 in their freshmen year and PWR 2 as sophomores.

Freshmen and sophomore seminars (see next paragraph) are not required but students regard them as a highpoint of their Stanford experience. You can work closely with a professor and with students who share your interest or curiosity in a particular topic. You can choose seminars to explore new areas or to check out a possible major. There are plenty of seminars in Engineering, but you should consider seminars from other areas as well. Almost all seminars will meet one or another of the "Ways" requirements.

EXPLORING ENGINEERING

There are several ways for students to explore the various engineering majors. One is through the Introductory Seminars and departmental seminars, and another is through the "Engineering Fundamentals." The Introductory Seminar program is described in detail in a separate publication from the Office of the Vice Provost for Undergraduate Education (VPUE), which you should receive as part of your orientation material. These seminars provide excellent opportunities for students to work with faculty in small settings, often on topics that aren't otherwise part of the curriculum for a particular major. You should *definitely* try to find a seminar that interests you, whether or not it's in engineering, and make that a part of your academic plans in your first or second year. Check <http://introductoryseminars.stanford.edu/> for the most current information

The 2014-2015 seminars in engineering are listed in the table on the following page. For course descriptions, consult the Explore Courses web site at

<http://explorecourses.stanford.edu/CourseSearch/>.

FRESHMAN/SOPHOMORE SEMINARS 2014-2015

Preference to Freshmen	Dept	Course #	Instructor
Managing Natural Disaster Risk	CEE	29N	Baker
Computers and Photography: From Capture to Sharing	CS	48N	Garcia-Molina
Great Ideas in Computer Science	CS	54N	Roberts
Computer and Information Security	CS	55N	Boneh
Digital Dilemmas	CS	74N	Dill
Elections and Technology	CS	76N	Dill
Hackers and Heroes	CS	81N	Winstein
Things about Stuff	EE	14N	Lee
The Art and Science of Engineering Design	EE	15N	Goldsmith
Engineering the Micro and Nano Worlds: From Chips to Genes	EE	17N	Pease
What is Nanotechnology?	EE	21N	Wong
Electronics Rocks	EE	27N	Kovacs
Man versus Nature: Coping with Disasters Using Space Technology [same as GEOPHYS 60N]	EE	60N	Zebker
Science of the Impossible	MATSCI	82N	Dionne
Form and Function of Animal Skeletons [same as BIOE 10N]	ME	10N	Carter
The Great Principle of Similitude	ME	13N	Santiago
How Stuff Is Made	ME	14N	Pruitt
Energy & The Industrial Revolution - Past, Present & Future	ME	16N	Majumdar
Haptics: Engineering Touch	ME	20N	Okamura
Preference to Sophomores			
Electric Automobiles and Aircraft	AA	116Q	Enge
Bon Appetit, Marie Curie! The Science Behind Haute Cuisine	BIOE	32Q	Covert
Medical Device Innovation	BIOE	70Q	Mandato, Pierce
Accessing Architecture Through Drawing	CEE	31Q	Barton
Place: Making Space Now	CEE	32Q	Barton,
Environmental Regulation and Policy	CHEMENG	60Q	Libicki
Masters of Disaster	CHEMENG	70Q	Moalli
Computational Modeling for Future Leaders	CME	20Q	Minion
Japanese Companies and Japanese Society [same as MATSCI 159Q]	ENGR	159Q	Sinclair
Product Realization: Making is Thinking	ME	103Q	Beach, Kohn, Edelman

Teamology: Creative Teams and Individual Development	ME	18Q	Wilde
The Worldly Engineer	ME	23Q	Su
The Flaw of Averages	MS&E	22Q	Savage
International Environmental Policy	MS&E	92Q	Weyant
Nuclear Weapons, Energy, Proliferation, and Terrorism	MS&E	93Q	Hecker

In addition to the above-listed seminars that offer the opportunity to work closely with faculty, many programs within the School of Engineering offer less intense one-unit seminars that provide exposure to key issues and current research within their disciplines. Generally, these seminars feature invited speakers and meet once a week for an hour or an hour and a half. They often require attendance only or attendance and modest participation, such as asking questions or writing brief responses to presentations. Some seminars (such as CHEMENG 10 and EE 100) are specifically designed to introduce new students to the field, while others (such as CS 547) are designed for upper-level undergraduates or graduate students, but are generally accessible to the interested non-expert. These seminars can provide a low-key way to explore different majors and research areas, and we encourage you to check out the ones in areas of interest to you. The following table lists some of the more popular seminars that have been offered in the past, but offerings do change from year to year: be sure to look in Axess each quarter for other such seminars in departments of interest.

Course	Department
CHEMENG 10. The Chemical Engineering Profession (Aut); 1 unit	Chemical Engineering
CS 546. Seminar on Liberation Technologies (A,W) CS 547. Human-Computer Interaction Seminar (A,W,S) 1 unit	Computer Science
EE 100. The Electrical Engineering Profession (A) 1 unit	Electrical Engineering
MS&E 472. Entrepreneurial Thought Leaders Seminar (A,W,S) 1 unit	Management Science & Engineering

The “Engineering Fundamentals” courses are an integral part of the undergraduate engineering curriculum and play a different role than the seminars. There are 22 such courses and each serves as an introduction to an engineering discipline, endeavoring to build a foundation for more advanced work (see Chapter 3, Figure 3-4 for a list). Each major requires a minimum of three fundamentals chosen from the list, one goal being to ensure that our students obtain some breadth in engineering outside of their major. If, as a freshman, you are fairly certain which field of engineering you want to pursue, you might consider taking one of the Fundamentals in that area.

MATHEMATICS COURSES

As a general rule, students interested in an engineering major should take a sequence of mathematics courses in their first year. Choosing which sequence to take, however, requires careful thought and the assistance of your advisor. Stanford offers several different entry points and options:

- MATH 41 and 42 present single variable calculus, with an emphasis on differential calculus in the first quarter and integral calculus in the second.
- MATH 19, 20, and 21 cover the same material as MATH 41 and 42, but do so in three quarters instead of two.
- MATH 51, 52, and 53* are taken by students who enter Stanford with 10 units of AP credit, or who have completed either MATH 42 or MATH 21. The 50 series covers differential and integral calculus in several variables, linear algebra, and ordinary differential equations. These courses are taught in an integrated fashion, with differential calculus of several variables and linear algebra being taught in MATH 51, integral calculus with linear algebra in MATH 52, and differential equations, including matrix methods for solving systems, in MATH 53. Students who are unsure of their mathematics preparation should consult with an advisor in the mathematics department before registering for this sequence. Some students have had the opportunity to cover differential and integral calculus in several variables, linear algebra, and/or ordinary differential equations in high school. In these cases students should consult with the Office of Student Affairs in 135 Huang to determine math placement and what requirements can be waived.

** Note: These courses do not include MATLAB. To get MATLAB experience with the MATH 50 series take 1-unit courses MATH 51M (autumn quarter only) or CME 192 (4-week course offered A, W, S).*

- MATH 51H, 52H, and 53H cover the same material as in 51, 52, and 53, but with more emphasis on theory and rigor. These courses are designed for students who have a strong interest in majoring in mathematics with an inclination toward pure mathematics.
- CME 100, 102, and 104 or 106 (same as ENGR 154, 155A, 155B, and 155C) cover material that is similar to that in the MATH 51, 52, 53 series, but do so in a different order and with a more explicit engineering focus. The Computational and Mathematical Engineering (CME) courses were developed for undergraduates interested in engineering. CME 100 presents multivariable calculus with engineering applications. It also introduces MATLAB, a computer program that integrates mathematical computing and visualization, providing a deeper, more visual understanding of the basic principles of multivariable calculus. MATLAB is incorporated throughout the CME series and will be useful in many later engineering and science courses. CME 100 can replace the material in MATH 51 and 52 in an engineering undergraduate's course requirements. Students can continue on with the

CME 102/104/106 sequence, which covers the rest of the introductory mathematics curriculum with an emphasis on engineering applications. CME 102 covers ordinary differential equations, CME 104 covers linear algebra and partial differential equations, and CME 106 covers probability and statistics for engineering. CME 102 may be taken before or after CME 100, while CME 106 requires either CME 100 or Math 51 as a prerequisite. CME 104 requires CME 102 as a prerequisite. Students who take both MATH 51 and CME 100 will receive only 7-8 units of credit due to duplication of material.

PHYSICS COURSES

The decision of whether to take a physics course in your first year is not nearly as simple as your decision about mathematics. Given the fact that you will also be taking required courses in writing and the humanities, taking both mathematics and physics in your first year pretty much fills your schedule, leaving little room for seminars or other courses that spark your interest. Furthermore, although all engineering majors require physics, it is often unnecessary to take physics so early in your undergraduate program. For students interested in engineering majors that depend heavily on physics, such as Engineering Physics, some aspects of Materials Science and Engineering, Mechanical Engineering, and Electrical Engineering, taking physics in your first year makes a great deal of sense because physics is a prerequisite for many of the advanced courses. For most other engineering majors, however, it probably makes sense to delay physics until your sophomore year, giving you more flexibility in your course schedule.

As with mathematics, there are several possible sequences that are appropriate for first-year students:

- **PHYSICS 41, 43, and 45** constitute the standard introductory sequence in physics and cover mechanics, electricity and magnetism, and light and heat, respectively. These courses are calculus-based and are generally far more intensive than typical high-school offerings, even at the advanced placement level. Even students who have taken AP Physics—and therefore do not in fact need the credits for these courses—find them challenging. Because the Stanford courses cover so much more material and do so with greater depth and rigor, it often makes sense to give up the Advanced Placement credits and take these courses. Talk with your advisor for guidance in this area. Note that PHYSICS 41 has prerequisites of high school physics or PHYSICS 19, and MATH 41 or 20 or 51 or CME 100 or equivalent. Minimum corequisite: MATH 42 or 21 or 51 or CME 100. See Figure 3-2, Courses Approved for the Science Requirement, in Chapter 3 for detail on all the physics courses.
- **PHYSICS 61, 63, and 65** offer a more advanced sequence designed for students who have mastered physics and calculus at the level of AP Physics C and AP

Calculus B/C in high school. This series is a good choice for prospective Engineering Physics or Physics majors and those interested in a more rigorous introduction to the field.

- **PHYSICS 21, 23, and 25** provide a lower-level introduction to basic physics primarily intended for premedical students. Most departments in the School of Engineering do not accept these courses and require students to take the 40 series or a more advanced offering. However, if you are intending to major in a discipline that *allows* students to take these courses, such as Computer Science or many of the degree options in Management Science and Engineering, these courses may represent an attractive option.

CHEMISTRY COURSES

For some engineering majors, such as Chemical Engineering and the School of Engineering majors associated with biology or medicine, taking a chemistry course in your first year is far more important than taking physics, largely because Stanford requires students to take a year of introductory chemistry before enrolling in biology. In order to get any advanced biology courses into a four-year degree, it is critical to begin the chemistry sequence early.

The two-quarter sequence Chemistry 31A and 31B is offered in the autumn and winter quarters respectively, and the one-quarter accelerated course, Chemistry 31X, is offered in the autumn quarter only. Additionally, students with a score of 5 on the Chemistry Advanced Placement Exam may continue to start in Chemistry 33, which is offered winter and spring quarters, but see the last paragraph in this section, below, about consequences for those preparing to apply to medical school.

Chemistry 31A and Chemistry 31B cover all the essential topics in general chemistry that are required to prepare students for the subsequent courses in the curriculum. Only the more advanced portions of these same topics are covered in Chemistry 31X. Both tracks use the same textbook and will arrive at the same endpoint. Thus, Chemistry 31X is an accelerated course for students with a strong background in high school chemistry. Chemistry 31A and 31B is for students with moderate or no background in high school chemistry. Chemistry 31A is a prerequisite for taking Chemistry 31B. Students must decide before autumn quarter whether or not they will take the two-quarter track because it will not be offered again until the following year.

In addition to the courses offered by the Chemistry Department, the School of Engineering offers the course ENGR 31, “Chemical Principles with Application to Nanoscale Science and Technology.” ENGR 31, offered autumn quarter only, provides a one-quarter freshman-level chemistry option that emphasizes topics and approaches that are of interest to engineers. The course will provide preparation in chemistry that is equivalent in rigor and scope to Chemistry 31 A&B, or Chemistry 31X. The applications of chemistry in materials technology will be discussed, including: relationships among the optical properties and electronic structures of molecules and solids; thermodynamics governing the reduction of oxide ores to produce high purity metals; kinetics of the chemical vapor deposition of silicon; the analogy between the pH of an aqueous solution and the Fermi Energy of electrons in a solid.

The chemistry placement exam is required for students who are interested in taking Chemistry 31X in autumn quarter 2014 but who do not have a 5 on the AP exam. Students with a limited background in chemistry should sign up for Chemistry 31A, autumn quarter, and may continue with 31B during winter quarter (there is no need for this latter group to take the placement exam). New students will take the test on Wednesday morning of Orientation Week. Returning students have an opportunity to take the placement test on Sunday evening.

Chemistry 33 is the next course in the chemistry sequence after Chemistry 31A and 31B, Chemistry 31X, or ENGR 31. It is offered in winter and spring quarters. Students in Chemistry 31 A and B should plan to take Chemistry 33 in spring quarter. Chemistry 35 can be taken in autumn or spring quarter with Chemistry 33 as a prerequisite. The laboratory course Chemistry 130 can be taken in the autumn quarter of a student’s second year with Chemistry 35 as a prerequisite.

Students with AP credit in chemistry forfeit this credit if they complete Chemistry 31X or Chemistry 31A and Chemistry 31B. Students who are planning to apply to medical school should be forewarned that not all medical schools accept AP credit. Therefore, it is recommended that pre-med students with a 5 on the Chemistry AP exam enroll in Chemistry 31X and not proceed directly to Chemistry 33. Questions concerning pre-med requirements should be directed to the Undergraduate Advising Programs office in Sweet Hall.

SUMMING UP

Here is some general advice that comes from the collective experience of the SoE advisors:

- *Get to know your advisor.* Every entering student at Stanford is assigned two advisors: an Academic Director who has an office in or near their residence, and a Pre-Major Advisor, a Stanford faculty or staff member, often working in a discipline in which the student has expressed an interest. In addition, student-athletes are assigned another academic advisor, specializing in NCAA compliance guidelines. All advisors have a good general sense of Stanford and its resources. Even if your advisor doesn't know the answer to one of your questions, they probably know where to find that answer. Your job is to establish a good relationship with your advisor so that you can draw on that wealth of knowledge and experience. See *Get help...* below for other advising suggestions.
- *Take a course that provides real engineering experience.* Too many students spend their entire first year taking nothing beyond mathematics, physics, and the required writing and humanities courses. Such schedules make it hard to feel the excitement that comes from the quintessentially engineering activity of making something work. There are many courses—particularly in the Introductory Seminar program—that will give you an opportunity to engage in problem solving within an engineering domain.
- *Maintain flexibility.* Each year, some of you arrive at Stanford absolutely convinced about your major and career plans; many more of you, however, will not be quite so certain by the end of your first year. Rather than commit early to a particular major or course of study, it makes sense to explore more broadly and to keep an open mind.
- *Get help when you need it.* Many students who start out with an interest in engineering end up leaving the field after running into problems in their introductory courses. While this decision is presumably the right one for some, the same talent and drive that got you into Stanford should enable those who remain passionate about engineering to succeed. If you need extra help to get through, Stanford has lots of assistance on offer. Here are some resources beyond your academic director and pre-major advisors to get you headed in the right direction: Try the Peer Advisor for your chosen major, the Office of Student Affairs in 135 Huang, the Center for Teaching and Learning (CTL), or look into the ACE program if you need extra help with math classes — don't wait until it is too late!
- *Plan ahead for an Overseas Program.* With careful planning, many engineering students can fit study at one of Stanford's overseas centers into their academic plans. Talk to your advisor as early as freshman year about planning for one or more quarters abroad (see "Engineers and Overseas Studies" section in Chapter 8).
- *Plan ahead for Coterm Degrees.* In the School of Engineering, all graduate programs allow students to study for a master's degree while completing their bachelor's degree. Because admission requirements and optimal application times vary, students are encouraged to talk early to the department in which they are interested (as early as end of sophomore year) to understand options, deadlines, etc. See Chapter 7 on "Other Degree Programs" or the *Bulletin* for more information.
- Have a wonderful year, and a successful time at Stanford.

2. TYPES OF ENGINEERING MAJORS & ACCREDITATION

Undergraduate programs in engineering fall into two categories:

- Departmental Majors
- School of Engineering Majors

These categories are described in the sections that follow.

DEPARTMENTAL MAJORS

A Departmental Major leads to the Bachelor of Science degree¹ in:

- Chemical Engineering (CHEME)
- Civil Engineering (CE)
- Computer Science (CS)
- Environmental Systems Engineering (ENVSE)
- Electrical Engineering (EE)
- Management Science and Engineering (MGTSC)
- Materials Science and Engineering (MATSC)
- Mechanical Engineering (ME)

Unlike undergraduate programs at Stanford outside of the School of Engineering, these majors share a common curricular structure and are subject to school-wide requirements:

- 36 units (minimum) to 45 units (maximum) of Mathematics and Science **combined**. (Departments may place individual minimums for both Mathematics and Science.)
- One course in Technology in Society (3 units minimum)

¹ Although it has “Engineering” in its title, Petroleum Engineering (now called Energy Resources Engineering) is offered by the School of Earth Sciences. For details, please see the *Stanford Bulletin*.

- Three courses in Engineering Fundamentals, at least one of which is left up to the student to choose
- Engineering Depth coursework within the particular engineering department such that the total units for Engineering Fundamentals and Engineering Depth coursework is at least 60 and no more than 72 units.

The total number of quarter units required ranges from 100 to 119. The specific total will depend on a particular department's Mathematics, Science, and Depth requirements.

Detailed program requirements for each of these Departmental Majors are given in Chapter 5, and lists of courses that have been approved for each category of the requirements appear in Chapter 3 of this Handbook.

SCHOOL OF ENGINEERING MAJORS

The School of Engineering offers several interdisciplinary programs leading to the Bachelor of Science degree in Engineering (ENGR-BS, BAS, or SEC. Some also offer the BSH degree). At present, there are eight such pre-approved sub-plans:

- Aeronautics and Astronautics (AA)
- Architectural Design (AD)
- Atmosphere/Energy (AE)
- Bioengineering (BioE)
- Biomechanical Engineering (BME)
- Biomedical Computation (BMC)
- Engineering Physics (EPhys)
- Product Design (PD)

In addition, students may opt to create an Individually Designed Major in Engineering (IDMEN-BS or BSH). Detailed program and declaration requirements for the pre-approved School of Engineering sub-plans and IDMEN appear in Chapter 5, along with the requirements for departmental majors.

ACCREDITATION

The Engineering Accreditation Commission (EAC) of the Accreditation Board for Engineering and Technology (ABET), an organization formed by the major engineering professional societies, accredits university engineering programs on a nationwide basis. An accredited program of study is usually the first step toward a professional engineering license. Advanced study in engineering at a graduate school sometimes presupposes completion of an accredited undergraduate program.

The accredited engineering programs at Stanford are Chemical Engineering, Civil Engineering, Environmental Engineering (until 2015)*, and Mechanical Engineering, all at the Bachelor of Science level. Computer Science, Electrical Engineering, Management Science and Engineering, and Materials Science and Engineering are not accredited programs by choice of the departments and the School; lack of ABET accreditation is no reflection on the quality of the department or program. Note that programs are accredited, not students or student programs. Program accreditation, however, is based, in part, on student records, which means that all students in these five programs must meet all accreditation criteria to graduate. Accreditation depends on whether a program meets a clearly defined set of objectives, which are in turn judged by whether students achieve a particular set of outcomes. The objectives and outcomes for each accredited program are included along with the description of that program.

The School of Engineering program sheets for the ABET-accredited programs lay out courses and units to ensure that all students have sufficient exposure to each of the cornerstones of engineering education: Math, science, engineering science/design, and experimentation.

In Accordance with ABET, the professional component must include:

- one year of a combination of college-level mathematics and basic sciences (some with experimental experience) appropriate to the discipline;
- one and one-half years of engineering topics, consisting of engineering sciences and engineering design appropriate to the student's field of study; and
- a general education component that complements the technical content of the curriculum and is consistent with the program and institution objectives.

*Environmental Engineering is no longer open to students not already declared. Those interested in this topic can choose to pursue the Wet Track in Civil Engineering or the new Environmental Systems Engineering program. Details on both programs can be found in Chapter 5.

3. COURSES APPROVED FOR SCHOOL OF ENGINEERING REQUIREMENTS

Nearly all engineering majors share similar requirements in Mathematics, Science, Technology in Society, and Engineering Fundamentals. The Undergraduate Council of the School of Engineering is responsible for establishing lists of courses certified as satisfying these requirements, which appear in the tables included in this section. Other appropriate courses—such as more advanced courses—may be used to satisfy these requirements, but their use must be approved by petition. Petition instructions and forms can be found in the “Forms” section of this handbook and are also on the Undergraduate Handbook website (<http://ughb.stanford.edu>). **A student must obtain petition approval prior to enrolling in any course that is not listed as approved to fulfill one of these requirements for the given major program.** Further information is available on pages 21-22 of this Handbook, on the UGHB website (the Petitions page), or in the Office of Student Affairs in 135 Huang.

THE MATHEMATICS REQUIREMENT

The mathematics requirements for departmental and School of Engineering majors are delineated by major in the detailed “Program Requirements” section in this Handbook (Chapter 5). In general, each program requires a number of specific and elective courses from the list of approved courses shown in Figure 3-1 on the next page. See page 5 of this handbook for a detailed discussion about the MATH 50 and CME 100 series: Courses from one of these series are required by most of the engineering programs. All engineering students should check their particular major program in Chapter 5 to see which mathematics and statistics courses are recommended or required.

FIGURE 3-1. COURSES APPROVED FOR THE MATHEMATICS & STATISTICS REQUIREMENTS

Course	Title	Units
Mathematics*		
MATH 19, 20, 21)	Calculus of a Single Variable	3, 3, 4
MATH 41 (A) and 42 (A,W)	Calculus of a Single Variable (accelerated)	5, 5
MATH 51** (A,W,S,Sum)	Linear Algebra & Differential Calculus of Several Variables	5
MATH 51M (A)***	Introduction to MATLAB for Multivariable Mathematics	1
MATH 52 (A,W,S)	Integral Calculus of Several Variables	5
MATH 53 (A,W,S,Sum)	Ordinary Differential Equations with Linear Algebra	5
MATH 51H, 52H, 53H	Honors Calculus	5, 5, 5
CME 100** (same as E 154)(AS)	Vector Calculus for Engineers	5
CME 102 (same as E155;AWS,Sum)	Ordinary Differential Equations for Engineers	5
CME 103 (A)	Introduction to Matrix Methods (same as EE 103)	4-5
CME 104 (same as E 155B) (S)	Linear Algebra and Partial Differential Equations for Engineers	5
CME 108 (W, Sum)	Introduction to Scientific Computing	3-4
CME 192 (A,W,S)***	Introduction to MATLAB (4 weeks; A,W,S)	1
CEE 101D/201D (A)	Computations in CEE	3
CS 103 (A,W,S,Sum)	Mathematical Foundations of Computing	3-5
ENGR 62 (MS&E 111) (A,S)	Introduction to Optimization	4
ENGR 154 (same as CME 100)	Vector Calculus for Engineers	5
ENGR 155A (same as CME 102)	Ordinary Differential Equations for Engineers	5
ENGR 155B (same as CME 104)	Linear Algebra and Partial Differential Equations for Engineers	5
MATH 104 (A,W,Sum)	Applied Matrix Theory	3
MATH 106 (A,S,Sum)	Functions of a Complex Variable	3
MATH 109 (W)	Applied Group Theory	3
MATH 113 (W,S)	Linear Algebra and Matrix Theory	3
MATH 115 (A,W,S,Sum)	Functions of a Real Variable	3
MATH 120 (A,S)	Groups and Rings	3
MATH 121 (W)	Galois Theory	3
MATH 131P (A,W), 132 (S)	Partial Differential Equations I, II	3, 3
MS&E 121 (S)	Intro to Stochastic Modeling	4
or more advanced Mathematics courses via approval of petition to deviate		
Statistics & Probability*		
CME 106 (W, Sum)	Introduction to Probability and Statistics for Engineers	3-4
STATS 60/160 (A,W,S,Sum)	Introduction to Statistical Methods: Precalculus	5
STATS 110 (A,Sum)	Statistical Methods in Engineering and the Physical Sciences	4-5
STATS 116 (A,S,Sum)	Theory of Probability	3-5
CS 109 (A,W,S)	Introduction to Probability for Computer Scientists	3-5
EE 178 (A,S)	Introduction to Probabilistic Systems Analysis	4
ENGR 155C (same as CME 106)	Introduction to Probability and Statistics for Engineers	3-4
MS&E 120 (A)	Probabilistic Analysis	5
MS&E 125 (S)	Introduction to Applied Statistics	4
CEE 203 (A)	Probabilistic Models in Civil Engineering	3-4
or more advanced Statistics courses numbered over 100 via approval of petition to deviate		

* Some major programs allow only specific courses or allow/require courses in addition to those listed above; check your major program sheet footnotes to see what specific courses can be applied toward each major.

** If MATH 51 and CME 100 are both taken, only 7-8 units of credit will be allowed toward the SoE major program.

*** Many majors (e.g. BioE) need MATLAB. Both MATH 51M and CME 192 are 1-unit MATLAB courses.

THE SCIENCE REQUIREMENT

The science requirements for departmental and School of Engineering majors are delineated in the detailed “Program Requirements” section in Chapter 5; all engineering students should check the their major section to see which science courses are recommended or required. In general, each program requires a number of specific and elective courses from the list of approved courses shown in Figure 3-2. Individually Designed Majors must include at least 17 units from the list that are appropriate for their course of study.

FIGURE 3-2. COURSES APPROVED FOR THE SCIENCE REQUIREMENT*

Course	Title	Units
<u>AP Credit:</u> Refer to AP chart on pg 24 and your PS footnotes to determine what is allowed in your program. Check to see that AP/IB/A-Level credit is recorded on your unofficial SU transcript.		
BIO 41 (A)	Genetics, Biochemistry, and Molecular Biology	5
BIO 42 (W)	Cell Biology and Animal Physiology	5
BIO 43 (S)	Plant Biology, Evolution, and Ecology	5
BIO 44X (W)	Core Molecular Biology Lab	5
BIO 44Y (S)	Core Plan Bio & Eco Evo Lab	5
CEE 63 (A)	Weather and Storms	3
CEE 64 (W)	Air Pollution: From Urban Smog to Global Change	3
CEE 70 (A) (same as ENGR 90)	Environmental Science and Technology	3
CHEM 31A, B (A,Sum;W,Sum)	Chemical Principles I, II	5,5
CHEM 31X (A)	Chemical Principles	5
CHEM 33 (W,S,Sum)	Structure and Reactivity (Prerequisite: 31A+B, or 31X, or an AP Chemistry score of 5)	5
CHEM 35 (A,S)	Synthetic & Physical Organic Chemistry	5
CHEM 36 (S; last time offered)***	Synthetic & Physical Organic Chemistry Lab I	3
CHEM 131(A,W)	Organic Poly Compounds	3
CHEM 135 (W)	Physical Chemical Principles	3
EARTHSYS 10 (A)	Introduction to Earth Systems	4
EARTHSYS 30 (S)	Ecology for Everyone (same as BIO 30)	4
ENGR 31 (A)	Chemical Principles with Application to Nanoscale Science	4
GES 1A (S)**	Introduction to Geology: The Physical Science of the Earth	5
GES 1B (A)**	Introduction to Geology: California Desert Geology	4
GES 1C (Not given 2014-15)**	Introduction to Geology: Dynamic Earth	4
PHYSICS 21,23,25 (A,W,S)	Basic Physics (allowed for CS & MS&E majors only)	3,3,3
PHYSICS 41 (W)	Mechanics (Prerequisite of MATH 41 or 20 or 51 or CME 100. Minimum co-requisite: MATH 21 or 42 or equivalent)	4
PHYSICS 43 (S)	Electricity, Magnetism (Prerequisite: PHYSICS 41 or equivalent + MATH 42 or 21 or 51 or CME 100 or equivalent. Recommended co-requisite: MATH 52 or CME 102)	4
PHYSICS 45 (A)	Light and Heat (Prerequisite: PHYSICS 41 or equivalent + MATH 42 or 21 or 51 or CME 100 or equivalent.	4
PHYSICS 42, 44, 46 (W,S,A)	Physics Labs	1,1,1
PHYSICS 61, 63, 65 (A,W,S)	Advanced Freshman Physics	4,4,4
PHYSICS 62, 64, 67 (A,W,S)	Advanced Physics Labs (<i>continued on next page</i>)	1,1,2

* AP Chemistry and Physics credit is also allowed; see page 26, Advanced Placement Credits or the Stanford Bulletin for details

** A maximum of 5 units of coursework from these courses may be counted toward the Science Requirement.

*** CHEM 36 is being phased out, offered for the last time in spring 2015. Instead, CHEM 33 and 35 will be five unit classes with two-hour labs (i.e. 10 units of CHEM 33 and 35 replaces the old 11 units for CHEM 33, 35, and 36).

THE TECHNOLOGY IN SOCIETY REQUIREMENT

It is important for the student to obtain a broad understanding of engineering as a social activity. To foster this aspect of intellectual and professional development, all engineering majors must take one course devoted to exploring issues arising from the interplay of engineering, technology, and society. Individual courses approved for the Technology in Society Requirement are listed in Figure 3-3. Petitions to use other courses to fulfill the Technology in Society Requirement will be considered strictly on their merits and will not be approved simply because the student has left the fulfillment of this requirement until his/her last quarter at Stanford.

FIGURE 3-3. COURSES APPROVED FOR THE TECHNOLOGY IN SOCIETY REQUIREMENT

Note: CE and MS&E majors must choose from among the courses marked “X” in the major columns. Students in other majors may choose from any of the following courses, although only BMC majors may use HUMBIO 174, BIOE 131 is limited to 20 students (preference to BioE majors), & only CS majors may take CS 181W. The WAYS column indicates which WAYS requirement can be fulfilled using the listed course (WAYS automatically fulfilled by other SoE requirements are not indicated).

Course	Title	Qtr	WAYS	Units	CE	MS&E
BIOE 131	Ethics in BioE (preference to BioE majors)	S	ER	3		
CLASSICS 151	Ten Things: An Archaeology of Design	Not offered 2014-15		4-5		
COMM 120W	Digital Media in Society (fulfills WIM)	Not offered 2014-15	SI	5	X	X
COMM 169	Computers and Interfaces	A	CE or SI	5	X	X
CS 181	Computers, Ethics and Public Policy (Prerequisite: CS 106B or X)	A,W,S	ER	3-4	X	X
CS 181W	Computers, Ethics and Public Policy (WIM for CS majors only) (Prereq: CS 106B or X)	A,W,S	ER	4	--	--
ECON 116	American Economic History (Prerequisite: ECON 1 or 1A)	S		5		
ENGR 130	Science, Technology, & Contemp. Society	Not offered 2014-15	SI	4-5	X	
ENGR 131	Ethical Issues in Engineering	A,S	ER	3	X	X
ENGR 145	Technology Entrepreneurship	A,W, Sum		4		
HUMBIO 174	Foundations of Bioethics (BMC majors; Prerequisite of HUMBIO core or equivalent)	S	ER	3	--	--

Continued on next page

MS&E 181	Issues of Technology and Work for a Post-Industrial Economy	S	SI	3	X	X
MS&E 193	Technology in National Security	A	SI	3		X
MS&E 197	Ethics and Public Policy	W	ER	5	X	X
POLISCI 114S	Int'l Security in a Changing World	W	SI	5		
PUBLPOL 122*	Biosecurity & Bioterrorism Response*	W		4		
PUBLPOL 194	Technology Policy	W		5	X	
STS 1	The Public Life of Science and Technology	W		5		

* PUBLPOL 122 must be taken for 4 units and have research topic must be approved in advance by Prof McGinn; email him with 125-word description of topic relevant to TiS by week 7 of the quarter at mcginn@stanford.edu.

THE ENGINEERING FUNDAMENTALS REQUIREMENT

The Engineering Fundamentals requirement is satisfied by a set of technically rigorous introductory courses chosen from the various engineering disciplines, as shown in Figure 3-4. These courses serve several purposes. First, they provide a breadth of knowledge about some of the major fields within engineering. Second, they furnish students with an opportunity to explore a number of engineering topics before embarking on a specific engineering major. Third, the individual classes each offer a reasonably deep insight into a contemporary technological subject for the interested non-engineer. Engineering majors (except those majoring in BMC or the Biocomputation track of CS) must complete a minimum of three Engineering Fundamentals courses, at least one of which is left up to the student to choose.

FIGURE 3-4. COURSES APPROVED FOR THE ENGINEERING FUNDAMENTALS REQUIREMENT

THE ENGR FUNDAMENTALS ARE A BREADTH REQUIREMENT. AS SUCH, ONLY ONE COURSE FROM EACH SET OF COURSES (25B/25E, 40/40N/40P, 50/50E/50M, AND 70A/70B/70X) MAY BE USED TO FULFILL THIS REQUIREMENT

Course	Title	Qtr	Units
ENGR 10	Introduction to Engineering Analysis	S, Sum	4
ENGR 14	Introduction to Solid Mechanics (limited enrollment)	A, W, S	4
ENGR 15	Dynamics	A, S	4
ENGR 20/CHEME 20	Introduction to Chemical Engineering	S	3
ENGR 25B/CHEME 25B	Biotechnology	S	3
ENGR 25E/CHEME 25E	Energy: Chemical Transformations for Production, Storage, and Use	W	3
ENGR 30	Engineering Thermodynamics	A, W, S	3
ENGR 40	Introductory Electronics	W	5
ENGR 40A	Introductory Electronics (first 7 weeks)	W	3
ENGR 40M	Making Stuff: What is EE	A, S	3-5
ENGR 40P	Physics of Electrical Engineering (same as EE 41)	W	5
Continued on next page			

ENGR 50	Intro to Materials Science, Nanotechnology Emphasis	S	4
ENGR 50E	Intro to Materials Science, Energy Emphasis	A	4
ENGR 50M	Intro to Materials Science, Biomaterials Emphasis	W	4
ENGR 60	Engineering Economy	Sum	3
ENGR 62/MS&E 111	Introduction to Optimization	W, S	4
ENGR 70A/CS 106A	Programming Methodology OR	A,W,S,Su	5
ENGR 70B/CS 106B	Programming Abstractions OR	A,W,S,Su	5
ENGR 70X/CS 106X	Programming Abstractions (Accelerated)	A,W	5
<i>Only one CS class allowed</i>	<i>Only one CS class allowed to count toward Fundamentals requirement</i>		
ENGR 80	Introduction to Bioengineering	S	4
ENGR 90/CEE 70	Environmental Science and Technology	A,Sum	3

THE EXPERIMENTATION REQUIREMENT

The departmental majors in Chemical, Civil and Mechanical Engineering require experimentation experience, which is included within the units taken for Science, Engineering Fundamentals, and Engineering Depth.

THE ENGINEERING SCIENCE AND ENGINEERING DESIGN REQUIREMENT

In order to satisfy ABET (Accreditation Board for Engineering and Technology) requirements, a student majoring in Chemical, Civil, Environmental, or Mechanical Engineering must complete one and a half years of Engineering Science and Engineering Design, also called engineering topics, in order to graduate. This requires a minimum of 68 units of Engineering Fundamental and Depth courses appropriate to the student's field of study. In most cases, students meet this requirement by completing the major program core and elective requirements. However, a student may need to take additional courses in Depth in order to fulfill the minimum requirement; see your major program description and program sheet in Chapter 5 for details.

4. POLICIES AND PROCEDURES

POLICY ON ACADEMIC PERFORMANCE

The Undergraduate Council of the School of Engineering has established the following standards of academic performance for all engineering majors.

Credit/No Credit Option

All courses taken in fulfillment of the requirements for an engineering major **must be taken for a letter grade** if the instructor offers that option.

Grade Point Average

Engineering major and minor students must achieve a Grade Point Average (GPA) of at least 2.00 for all courses taken in fulfillment of the Engineering Fundamentals and Engineering Depth requirements (or, in the case of a student in a Minor program, 2.0 total across all courses taken for the minor). Departments may set a higher GPA if they choose. A student's GPA is a weighted average of numerical grade points. The calculation is based on a 4-point system, with + and – modifiers counting as 1/3 of a grade point (e.g., a C+ is counted as 2.33). The grade for each course taken to satisfy the Engineering Fundamentals and Engineering Depth requirements is weighted by the unit value of the course and an average is then obtained. Thus, courses in which a grade higher than a C is earned offset courses in which less than a C is earned. Details of the University GPA calculation can be found at

<http://www.stanford.edu/dept/registrar/academic/grades.html#GPA>. The GPA calculation does not apply to courses taken to satisfy the Math, Science, or Technology in Society requirements.

DEVIATION PETITIONS AND SUBSTITUTIONS

Students have the right to petition for deviations from curricular requirements. If the action requested involves a requirement imposed by the University itself, such as the General Education or Foreign Language Requirements, the petition process is handled through the Student Services Center, located in the 2nd floor of Tresidder Union or online at studentservicescenter.stanford.edu. For petitions to deviate from engineering program requirements, see the next page.

Departmental Depth: If the petition involves a Departmental Depth requirement, the major department handles the request. Each department has its own procedures, and the student is advised to consult with his or her student services staff within the major department for guidance (see the list of room numbers on the inside front cover of this Handbook), and then with the advisor. **A deviation from an Engineering Depth requirement must be initialed and dated in ink by the advisor on the student's final Program Sheet that is submitted before graduation.**

Math, Science, Technology in Society, or Engineering Fundamentals: If the action requested involves one of the School of Engineering requirements, the student should submit a Program Deviation petition to the Office of Student Affairs in 135 Huang. The petition must be submitted on the School's official petition form, a copy of which is in the "Forms" section of this Handbook, and which may also be downloaded from the UGHB website at <http://ughb.stanford.edu>. **The petition must be signed by your departmental student services contact and advisor, and accompanied by an up-to-date copy of your Program Sheet, preferably the one on file with your department.** Completed SoE petitions should be submitted in the Office of Student Affairs, 135 Huang.

Submit petitions to transfer credit, to make course substitutions, or to alter graduation requirements as early as you know a petition will be necessary, preferably at least two quarters prior to your expected date of graduation, or two weeks prior to the add/drop deadline of your final quarter at latest. This will allow you time to make arrangements to take the original course or to petition for another course if your petition is denied.

TRANSFER CREDIT

Many students elect to take some of their coursework at another institution. In addition, each year a small number of engineering students enter Stanford after completing one or two years at another institution. In either case, these transfer credits are subject to the guidelines below.

Step One: Registrar's Office

All units of transfer credit that are to be applied toward the University graduation requirement of 180 units must be approved by the Registrar's Office. Students must petition the University for approval; go to the Transfer Credit link on the Registrar Student website at

<http://studentaffairs.stanford.edu/registrar/students/transfer-credit/procedures> for policies and procedures. Transfer courses may satisfy general University requirements or

School of Engineering requirements. Such credits require specific, case-by-case approval. Those credits that meet general University requirements will appear on both your Stanford unofficial and official transcripts, generally within four weeks after the Office of the University Registrar has received both your petition and your transfer school's official transcript. Pre-approval notification will generally be emailed within four weeks. Only courses graded "C-" or above are transferable. To receive credit for courses used for your engineering major, see Step Two.

Step Two: Petition to SoE Dean's Office (SoE Requirements) OR to Department (Depth)

Transfer credits that you want to use to meet engineering requirements must have School of Engineering approval prior to your final quarter. University approval is necessary, but not sufficient. You must petition to transfer credit(s) in the areas of:

- **Math, Science, Technology in Society and Engineering Fundamentals (SoE Breadth requirements)**

These courses require approval by the SoE Dean's Office. Submit your petition and accompanying documents (see Petition Forms and Documents below) in 135 Huang.

- **Depth**

Depth coursework requires approval by your major or departmental advisor. Departments have considerable latitude in deciding whether to approve transfer requests. Departments may require that certain courses be taken at Stanford and may establish limits on the total number of transfer courses.

Petition Forms and Documents: To have transfer credits evaluated for use in your major, take the following forms and documents to either the Dean's office (SoE requirements) or the departmental advisor (depth courses):

- A completed Petition of Transfer Credit form, found in the "Forms" section of this handbook or on the web at <http://ughb.stanford.edu> (this Web form may be downloaded and filled out electronically). Indicate on the form which Stanford course or courses are considered equivalent; if the equivalence is uncertain, a faculty member from the field in question should be consulted. Include all courses, grades, and units taken for your major.
- Current Program Sheet (use the original on file with your major department, if you have already declared; or fill out a new version if the original is out of date). The course you want to transfer should be listed on your Program Sheet by its equivalent Stanford course number, followed by its title, followed by the course number at the other school, followed by a check mark in the **Transfer** column.
- A catalog description of the course from the other institution.

- Unofficial copy of your SU transcript from Axess
- Request that the Stanford Student Services Center forward a copy of your transcript from the other institution to either your department or to the SoE Dean's office, depending on the course(s) being petitioned. The transcript must come to your department or the Dean's office from the SU Registrar's Office, not directly from the school where you took the course. This indicates to the SoE that the University has already accepted the credit, an essential first step in receiving credit for your major.

The results of your SoE petition will be emailed to you and the original petition documents mailed to your major department. The department will notify you of Depth petition results. Approval of transfer credits is indicated by the appropriate initials and date on your Program Sheet in the Transfer/AP Approval column.

While the Office of Student Affairs and the student's Major Advisor evaluate transfer credit requests on a case-by-case basis, the following general guidelines apply:

- Transfer courses should be substantially equivalent to those offered at Stanford.
- The number of units transferred for a given course is usually equal to the number of units taken at the other institution, adjusted for different unit values at the two schools. For example, a 3-unit course at a semester-based school will usually transfer as 4.5 units in Stanford's quarter system.

Transfer Students: All engineering transfer students should arrange to see the Senior Associate Dean for Student Affairs in 135 Huang during their first year at Stanford for an evaluation of transfer credits toward School of Engineering requirements.

ADVANCED PLACEMENT CREDITS 2014-15

Test Subject	Score	Placement	Quarter Units
Calculus AB	5	MATH 51	10
Calculus AB	4	MATH 42	5
Calculus BC	4,5	MATH 51	10
Calculus BC	3	MATH 42	5
Chemistry	5	CHEM 33 or above	4
Computer Science A	4,5	CS 106B or 106X	5
Computer Science AB	4,5	CS 106B, 106X, or 107	5
Physics B	5	PHYSICS 25	8
Physics B	4	PHYSICS 23 and 25	4
Physics C Mechanics only	4,5	PHYSICS 43 and 45 or	5
Physics C E&M only	4,5	PHYSICS 41 and 45	5
Physics C Mechanics or E&M only	3	PHYSICS 41,43 and 45	4
Physics C Both Parts	4,5	PHYSICS 45 or	10
Physics C Both Parts	3	PHYSICS 41,43 and 45	8

Advanced Placement (AP) credits apply toward both the university 180-unit requirement and the School of Engineering requirements in Mathematics, Chemistry, Physics, and Computer Science (see approval process below). AP credits in mathematics are applied only if the parallel Stanford courses are skipped. Thus, a student cannot receive 10 units of AP mathematics credit and then enroll in MATH 41; to apply these AP units at Stanford, the first mathematics course taken must be beyond the MATH 40 series, typically MATH 51 or CME 100. AP credits in Chemistry and Physics are accepted as satisfying the School of Engineering Science requirement, though some departments prefer that you retake certain courses at Stanford (e.g., Environmental Engineering majors are encouraged to take CHEM 31X and forfeit their AP Chemistry credit). Note that AP Physics C counts toward the Physics 40 series, whereas AP Physics B applies only to the non-calculus-based Physics 20 series. See the *Stanford Bulletin* for further details on AP policy.

To receive approval for math and science AP credits, take your Program Sheet and a copy of your unofficial SU transcript to 135 Huang. Approval of Advanced Placement is indicated by the appropriate initials and date on the Program Sheet (bring in your current PS on file in your major department, not a copy) in the **Transfer/AP Approval** column. The initials “AP” should be entered in the title column, followed by the number of units in the Total Units column.

GRADUATION PROCEDURES

Four separate approvals are needed to certify completion of all requirements for conferral of the bachelor’s degree:

REQUIREMENT		APPROVER
1)*	Depth courses in your major program (listed on the second page of your Program Sheet)	Go to major department Student Services for review of your PS. Most require an advisor and departmental signature; inquire before enrolling in your final quarter courses so corrections to your program can be made, if needed.*
2)	Writing, Language, GERS/WAYS (completion of University requirements)	Information available on Axxess, or consult with your advisor or the Student Services Center
3)	School of Engineering/department requirements (Math, Science, TIS, Fundamentals) to complete major program	Your department will forward your major file to the Dean’s office in 135 Huang for final approval of your Engineering program
4)	Completion of University-required units and final approval for degree conferral	Stanford University Senate

*Student must initiate this review and signature process early in their senior year.

Students nearing the completion of their degree programs must do the following to assure that they graduate on time:

1. School of Engineering Program Sheet—An up-to-date, completed, and recently signed program sheet form must be in your departmental academic file before the deadline to apply to graduate of your final quarter. Program sheets for each department are included in the detailed program descriptions later in this Handbook, and are available electronically from the online version of the Handbook at <http://ughb.stanford.edu>. Students in most majors are required to obtain signatures from their advisor, student services administrator, and in some cases, departmental chair, indicating that their major program is complete and approved. Review your final program sheet with your department at least two quarters in advance of your final quarter in order to allow time to correct errors in your program and file any necessary petitions.

Any transfer courses used for SoE requirements or deviations from the major plan must be clearly indicated on the program sheet, with the appropriate approvals by the advisor or Dean's office in ink in the given spaces. (The transfer credit process is described in detail earlier in this section under the heading "Transfer Credit.")

Deviations from a previously approved program must be evaluated and re-approved by your department (your Student Services administrator) AND by your advisor. Deviations in the Math, Science, Technology in Society, and Engineering Fundamental areas need to be petitioned for approval by the Dean's Office in 135 Huang after first obtaining departmental approval. Petition forms are available on the web at <http://ughb.stanford.edu>. Deviations in Engineering Depth need be approved only by the student's department and advisor. Approval of a deviation is indicated by the appropriate signature/initials and date in ink on the **final** Program Sheet. In other words, if your program has deviated in any way from what is on the signed Program Sheet, the change must be approved and the PS signed again prior to your filing to graduate.

The program sheet must list all courses taken for the major, including those in which you are currently enrolled. You should delete any courses not taken from the sample program given, and fill in grades and units for every course. Grades in courses taken the quarter of graduation will be added to the program sheet by the Dean's office staff as they become available at the end of Finals Week.

If you are a Coterm student, you must check your undergraduate transcript on Axess to ensure that any course needed for your BS degree appears there and has not inadvertently been assigned to your MS career.

2. At the appropriate time as listed in the University Calendar, an *Intent to Graduate* application should be filed through Axess.
3. Status for completion of the University's Writing, GER (or WAYS), and Foreign Language requirements should be verified through Axess. Completion of the Engineering Requirements will be verified by the SoE Dean's office in 135 Huang.

5. PROGRAM DESCRIPTIONS AND REQUIREMENTS FOR ENGINEERING MAJORS

Within the context of the broad, liberal-arts education that is the hallmark of all Stanford undergraduate programs, the School of Engineering strives to provide the scientific and technical education necessary for both a satisfying and productive engineering career and for a successful graduate school experience. The curricula of the School emphasize fundamental knowledge, tools, and skills, while allowing many opportunities for engineering students to take advantage of the excellent courses and programs offered by the other schools of the University. About 10 percent of all engineering majors choose to double-major, many study overseas for a quarter or more, and most are involved in extracurricular activities. While engineering curricula are among the most demanding at the University and require careful academic planning to take full advantage of the many opportunities at Stanford, we aim to strike a balance between the technical sophistication and the social and cultural breadth demanded of engineers in modern society.

Engineering courses, however, represent only a part of a liberal-arts education. To ensure that every engineer receives a well-rounded undergraduate experience, all students must meet the general requirements of the University in addition to the disciplinary requirements for a degree in engineering. These requirements are detailed in other University publications such as the *Stanford Bulletin* and *Approaching Stanford*.

UNDERGRADUATE PROGRAM SHEETS

A student's undergraduate **Program Sheet** is an essential document for planning and for degree certification by the School of Engineering. In effect, it represents the student's "contract" with the School of Engineering, because completion of all courses listed on the sheet is a requirement for receiving the BS, BSH, or BAS degree with a major in the School. Each department has its own requirements regarding program sheets but, in general, a student is advised to complete a form as s/he prepares to declare her/his major AND during the first or second quarter of their senior year.

CREATE A PROGRAM SHEET

You will see examples of Program Sheets for each of the majors in the sections that follow.

These Program Sheets represent sample full or partial curricula for the majors, not a complete program that must be followed exactly in all cases. Your personal Program Sheet is created by you: Go to <http://ughb.stanford.edu> and choose from a selection of departmental and blank Program Sheets; each major program has one or more on file. You may fill it out electronically or in hardcopy. Carefully review the notes and footnotes on the Program Sheet for directions on completing the form, and for details about major courses and alternatives. Remember that each course can only be listed under one category on the program sheet; that is, a course may not “double count” for more than one requirement. You may select a Program Sheet from any year in which you are enrolled at Stanford.

SUBMIT A PROGRAM SHEET TO YOUR DEPARTMENT

A signed copy of your own Program Sheet generally must be submitted to the major department when you declare and again by the beginning of the quarter prior to the quarter in which you intend to graduate. The Dean’s office will not approve a student to graduate unless they turn in an updated and signed program sheet to their department during their senior year, preferably fall or winter quarter for a student graduating spring quarter.

REVISING AN APPROVED PROGRAM SHEET

A program sheet that has been approved and signed by your advisor must be resubmitted for approval if you change your program. That is, any deviation from required courses or transfer of credit from another institution must be petitioned using your current program sheet, which you should then have re-approved/re-signed by your advisor and department. The final program sheet you will use to graduate must have all changes initialed and dated in ink by your advisor, and must be reviewed and signed by your department, etc. See Chapter 4 for details on petitions. Petitions to alter graduation requirements, for transfer credit evaluation, or for course substitutions should be submitted as early as possible and always at least one quarter before your final quarter as an undergraduate student.

FULFILLING REQUIREMENTS FOR ACCREDITED PROGRAMS

The Program Sheet provides a convenient way to assess a program with respect to accreditation requirements, which are not the same as the School’s curricular requirements. In order to satisfy Accreditation Board for Engineering and Technology (ABET) requirements, a student majoring in Chemical, Civil, Environmental, or Mechanical Engineering must complete one and a half years (minimum of 68 units) of Engineering Topics appropriate to the student’s field of study.

DECLARING AN ENGINEERING MAJOR

Stanford has a long-standing policy that any student may declare any major. Hence, there are no separate “entrance” requirements for the School of Engineering. Students at Stanford also have considerable time to weigh their choice of major, and it is useful to take a variety of courses in engineering before settling on a particular major. The majors offered by the School of Engineering are demanding, but also extremely rewarding.

Students at Stanford must declare a major by the time they achieve junior status (85 completed units). Prospective Engineering majors should review their departmental program section for any major-specific declaration procedures. As the final step, students will formally declare their major in Axxess. The link for Declaring a Major/Minor is under the Academics tab.

- Departmental majors (CHEME, CE, CS, EE, ENVSE, MGTSC, MATSC, ME) should select a Department Plan. Check your major program section in Chapter 5 for detailed instructions.
- Engineering majors (Aeronautics and Astronautics, Architectural Design, Atmosphere/Energy, Bioengineering, Biomechanical Engineering, Biomedical Computation, Engineering Physics, and Product Design) should select “Engineering” as their plan and then the appropriate Subplan. Check your major program section in Chapter 5 for detailed instructions.
- Individually Designed Majors must submit a paper copy of the *Declaration or Change of UG Major, Minor, Honors* form to the SSC in order to declare an IDMEN plan. Check the IDMEN major program section in Chapter 5 for detailed instructions.

You must satisfy department or program declaration requirements before you are officially declared in a major; see instructions for each major in the appropriate section of Chapter 5. Your academic record will not be changed until you have satisfied all requirements. When the department certifies in Axxess that you have met its declaration requirements, an email message will be sent to notify you that your academic record has been updated.

MAJOR PROGRAMS AND THEIR REQUIREMENTS

In the following sections you will find detailed descriptions of the programs (in alpha order by program name, with all ENGR programs under Engineering Subplan Majors):

- **Chemical Engineering**
- **Civil Engineering**
- **Computer Science**
- **Electrical Engineering**
- **Engineering Subplan Majors:**
 - **Aeronautics and Astronautics**
 - **Architectural Design**
 - **Atmosphere/Energy**
 - **Bioengineering**
 - **Biomechanical Engineering**
 - **Biomedical Computation**
 - **Engineering Physics**
 - **Product Design**
- **Environmental Systems Engineering**
- **Management Science and Engineering**
- **Materials Science and Engineering**
- **Mechanical Engineering**
- **and the**
- **Individually Designed Major in Engineering**

AERONAUTICS AND ASTRONAUTICS

Stanford's Department of Aeronautics and Astronautics prepares students for professional positions in industry, government, and academia by offering a comprehensive program of graduate teaching and research. In this broad program, students have the opportunity to learn and integrate multiple engineering disciplines. The program emphasizes structural, aerodynamic, guidance and control, and propulsion problems of aircraft and spacecraft.

The principal purpose of the undergraduate interdisciplinary major in Aeronautics and Astronautics is to provide an opportunity for interested undergraduates to become acquainted with the challenges of the aerospace field, aeronautical and astronautical principles, and the faculty who teach and do research in aeronautics and astronautics. Primarily, the program is designed for students who are strongly interested in aerospace and will pursue subsequent graduate study in the field.

Students interested in aerospace are also encouraged to consider the undergraduate minor in Aeronautics and Astronautics, which is described in the "Minors and Honors" section of this Handbook.

The departmental requirements of this major include a core set of courses required of every Aeronautics and Astronautics major; a set of depth areas from which two areas (four courses) must be chosen; and two engineering electives. Students are expected to consult closely with an advisor about how to satisfy these and all other requirements of the major, submit a program planning sheet when declaring the major, and have a final plan (program sheet) approved by the advisor and department at least one quarter prior to graduation.

REQUIREMENTS

Mathematics: 24 units (Fr, So, Jr)

One single-variable calculus series is required: MATH 41 & 42 or 10 Units of AP Calculus credit. Mathematics through ordinary differential equations is a required as a prerequisite to depth courses: CME 100 & 102 (preferred) or MATH 51 & 53. In addition, one statistics course is mandatory: CME 106 (preferred), STATS 110, STATS 116, or CS 109. Finally, CME 104 (MATH 52) is recommended, but not required.

Science: 19 units (Freshman, Sophomore)

Aero/Astro depth courses rely on a strong foundation in classical physics, particularly mechanics, learned in the required PHYSICS 41 series: PHYSICS 41, 43, & 45. A score of 4 or a 5 on the AP Physics C Mechanics test places the student out of PHYSICS 41; a score of 4 or a 5 on the AP Physics C Electricity & Magnetism test places the student out of PHYSICS 43.

One quarter of chemistry is required for students: CHEM 31X (preferred), ENGR 31, CHEM 31A+B (counts for one quarter, 5 units), or 5 units of AP Chemistry credit. Students are required to take 3 or more additional units of science, fulfilled by the 40 Series Lab Courses (PHYSICS 42, 44, & 46, 1-unit each) or by another Science Elective. For a list of Science Electives approved by the School, see the Science Requirement section of this handbook (Fig 3-2).

Technology in Society: One course (3-5 units)

See Chapter 3, Figure 3-3 for a list of courses that fulfill the Technology in Society requirement.

ENGINEERING FUNDAMENTALS:

Three courses minimum, at least one of which is left up to the student to choose.

Course	Title	Units
ENGR 30	Engineering Thermodynamics (req'd)	3
ENGR 70A	Programming Methodology (req'd) (same as CS 106A)	5
	Fundamentals Elective* (may not use ENGR 70B/X, same as CS 106B or X)	

DEPARTMENTAL REQUIREMENTS: 48 UNITS

Course	Title	Units
AA 100	Introduction to Aeronautics & Astronautics	3
AA 190	Directed Research & Writing in Aero/Astro **	3-5
ME 70	Introductory Fluids Engineering	4
ME 131A	Heat Transfer	3
ENGR 14	Introduction to Solid Mechanics	4
ENGR 15	Dynamics	4
ME 161 <i>or</i> PHYSICS 110	Dynamic Systems (3) Intermediate Mechanics	3-4
CEE 101A <i>or</i> ME 80	Mechanics of Materials Mechanics of Materials	4
Engineering Depth Electives	Two elective courses (see Figure AA-1 below)	3-5 each
Depth Area I	two courses from a department Depth Area (see Figure AA-2 below)	6
Depth Area II	two courses from a second Depth Area (see Figure AA-2 below)	6

*For a list of approved Fundamental Elective courses, see Figure 3-4

** Students should discuss their AA190 (WIM) topic with their advisor & the Student Services Manager during their junior year.

Aero/Astro Depth

Select two Engineering Electives; see Fig AA-1 for a list of options. Students may also use additional courses from any of the Depth Areas to fulfill the Engineering Elective requirement. To fulfill Depth Area requirements, select four courses, two from each of two areas; see Fig AA-2 for a list of options. The choice of depth areas and engineering electives should be determined in consultation with the Aeronautics and Astronautics major advisor

FIGURE AA-1. ENGINEERING ELECTIVES*

Course	Title	Units
AA 250	Nanomaterials for Aerospace	
ENGR 240	Introduction to Micro and Nano Electromechanical Systems	3
ME 210	Introduction to Mechatronics	4
ME 220	Introduction to Sensors	3-4
ME 227	Vehicle Dynamics and Control	3
ME 250	Internal Combustion Engines	3-5
ME 257	Turbine and Internal Combustion Engines	3
ME 260	Fuel Cell Science and Technology	3
ME 324	Precision Engineering	4
ME 331A	Advanced Dynamics and Computation	3
ME 331B	Advanced Dynamics, Simulation and Control	3
ME 345	Fatigue Design and Analysis	3
ME 348	Experimental Stress	3
ME 351A	Fluid Mechanics	3
ME 351B	Fluid Mechanics	3
CHEMENG 140	Micro and Nanoscale Fabrication Engineering	3
CS 107	Computer Organization and Systems	3-5
CS 110	Principles of Computer Systems	3-5
CS 140	Operating Systems and Systems Programming	3-4
CS 161	Design and Analysis of Algorithms	3-5
EE 102A	Signal Processing and Linear Systems I	4
EE 102B	Signal Processing and Linear Systems II	4
EE 101A	Circuits I	4
EE 101B	Circuits II	4
EE 108	Digital Systems Design	4
EE 180	Digital Systems Architecture	3-4
ENERGY 121	Fundamentals of Multiphase Flow	3
ENERGY 191	Optimization of Energy Systems	3
ENERGY 226	Thermal Recovery Methods	3
MATSCI 155	Nanomaterials Synthesis	4
MATSCI 156	Solar Cells, Fuel Cells, and Batteries: Materials for the Energy Solution	3-4
MATSCI 197	Rate Processes in Materials	3-4
MATSCI 198	Mechanical properties of Materials	3-4
PHYSICS 100	Introduction to Observational and Laboratory Astronomy	3-4

*It is recommended that students review prerequisites for all courses.

FIGURE AA-2. DEPTH AREA: FOUR COURSES, TWO FROM EACH OF TWO AREAS*

Course	Title	Units
Dynamics and Controls		
ENGR 105	Feedback Control Design	3
ENGR 205	Intro to Control Design Techniques	3
AA 203	Introduction to Optimal Control Theory	3
AA 222	Introduction to Multidisciplinary Design Optimization	3-4
AA 242A	Classical Dynamics	3
AA 271A	Dynamics and Control of Spacecraft and Aircraft	3
Systems Design		
AA 236A	Spacecraft Design	3-5
AA 236B	Spacecraft Design Laboratory	3
AA 241A	Introduction to Aircraft Design, Synthesis, and Analysis	3
AA 241B	Introduction to Aircraft Design, Synthesis, and Analysis	3
AA 284B	Propulsion System Design Laboratory	3
Fluids and CFD		
AA 200	Applied Aerodynamics	3
AA 201A	Fundamentals of Acoustics (not given 2014-15)	3
AA 210A	Fundamentals of Compressible Flow	3
AA 214A (CME 206)	Introduction to Numerical Methods for Engineering	3
AA 283	Aircraft & Rocket Propulsion	3
ME 131B	Fluid Mechanics: Compressible Flow and Turbomachinery	4
ME 140	Advanced Thermal Systems	5
Structures		
AA 240A	Analysis of Structures I	3
AA 240B	Analysis of Structures II	3
AA 256	Mechanics of Composites	3
AA 280	Smart Structures	3
ME 335A	Finite Element Analysis	3

*It is recommended that students review prerequisites for all courses.

Note: The online version of your major (link from the Home or Major Programs page of the UGHB website) is considered the definitive version of 2014-15 requirements; corrections or updates may have been made after the printed and pdf versions were published in August 2014.

★ You must use a program sheet from a year you have been enrolled at Stanford.

Aeronautics and Astronautics

Sample Program with Math 40 and Physics 40 Series Start

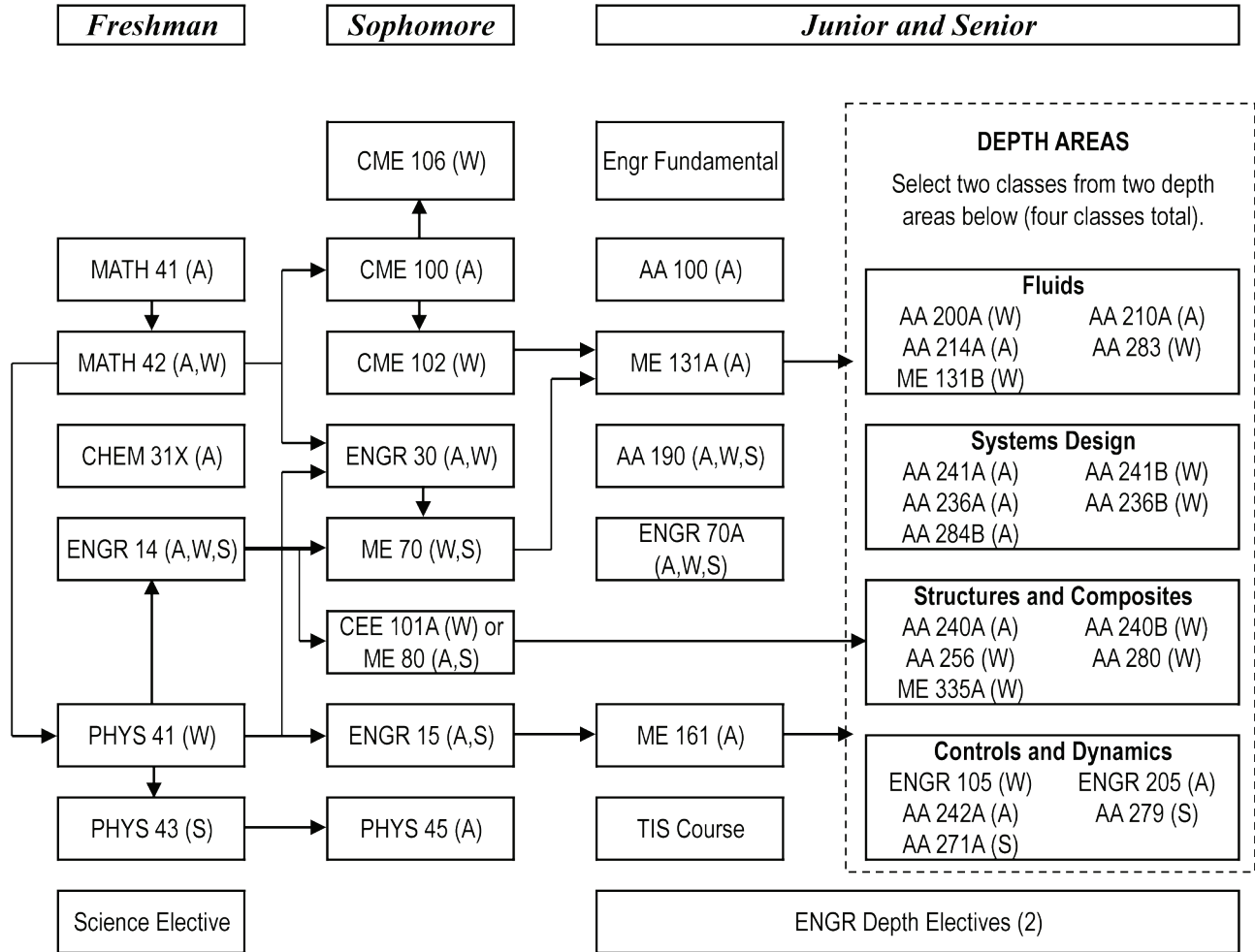

Aeronautics and Astronautics

Sample Program with AP Calculus and AP Physics C Credit

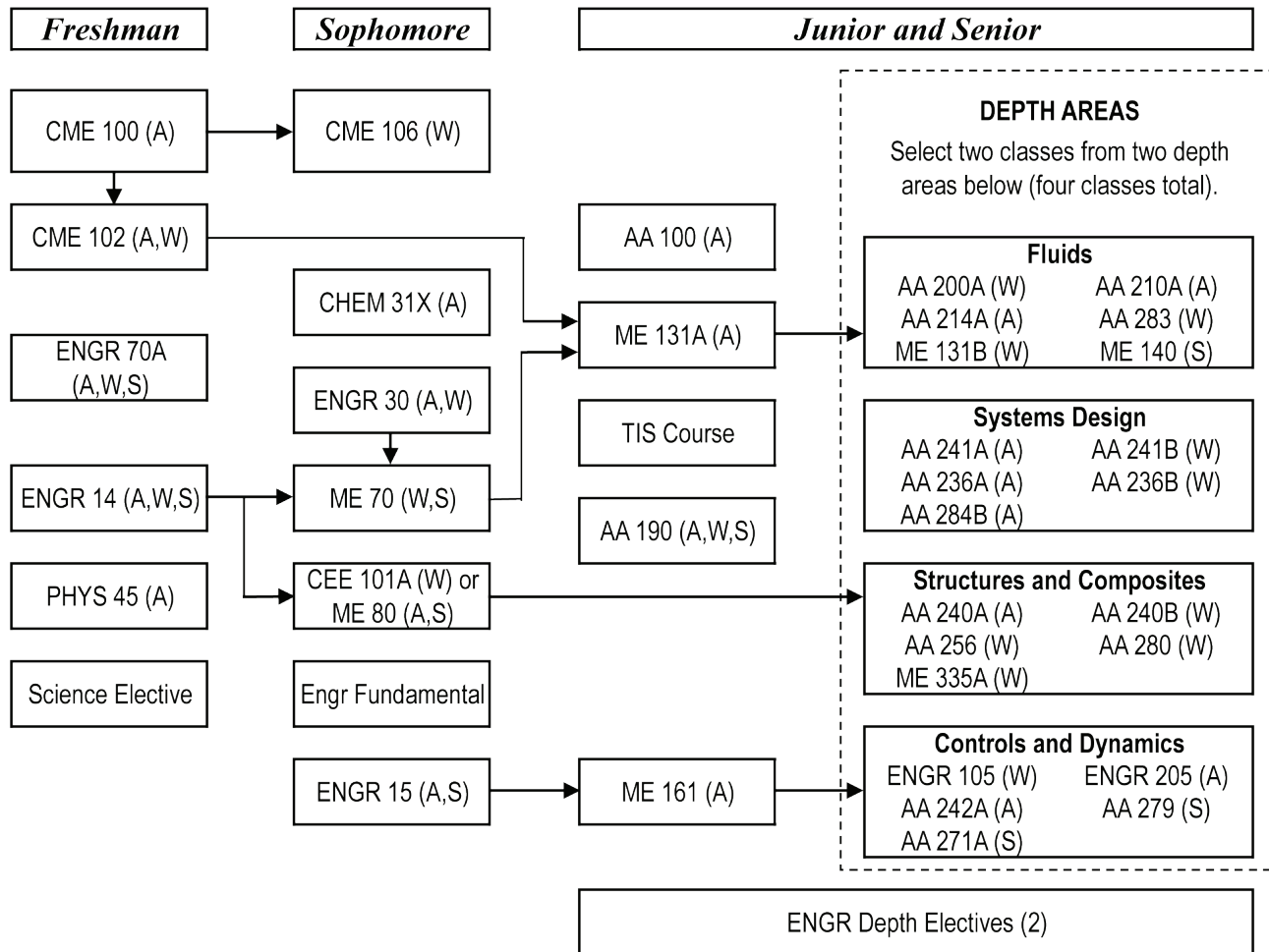

Aeronautics and Astronautics

Sample Program with AP Calculus and AP Physics C Credit* (adds 18 units of Math & Science)

	<i>Fall</i>				<i>Winter</i>				<i>Spring</i>				
	Math/ Sci	Engr	Other		Math/ Sci	Engr	Other		Math/ Sci	Engr	Other		
<i>Freshman</i>	PHYSICS 45	4	-	-	ENGR 70A	-	5	-	THINK	-	-	4	
	PWR	-	-	4	Intro Sem	-	-	3	Sci Elective	3	-	-	
	CME 100	5	-	-	CME 102	5	-	-	ENGR 14	-	4	-	
									IntroSem			3	
	<i>Subtotals</i>	9	0	4	<i>Subtotals</i>	5	5	3	<i>Subtotals</i>	3	4	7	
<i>Sophomore</i>	Total			13	Total			13	Total			14	
	PWR	-	-	4	Engr fund.	-	3	-	ENGR 15	-	4	-	
	ME80	-	4	-	CME 106	4	-	-	IntroSem	-	-	3	
	CHEM 31X	4	-	-	ENGR 30	-	3	-	ME 70	-	4	-	
				Elective	-	-	4	WAYS	-	-	3		
	<i>Subtotals</i>	4	4	4	<i>Subtotals</i>	4	6	4	<i>Subtotals</i>	0	8	6	
<i>Junior</i>	Total			12	Total			14	Total			14	
	ME 131A	-	3	-	Depth course	-	3	-	Depth Course	-	3	-	
	ME 161	-	3	-	Language	-	-	5	Language	-	-	5	
	Language	-	-	5	Engr Elective	-	3	-	Elective	-	-	4	
	AA 100	-	3	-	AA 190	-	3	-					
	<i>Subtotals</i>	0	11	5	<i>Subtotals</i>	0	9	5	<i>Subtotals</i>	0	3	9	
<i>Senior</i>	Total			15	Total			14	Total			12	
	WAYS	-	-	3	Elective	-	-	4	Elective	-	-	4	
	Depth Course	-	3	-	Depth Course	-	3	-	Elective	-	-	4	
	TIS course	-	-	3	Engr Elective	-	3	-	Elective	-	-	3	
	Elective			4	WAYS	-	-	3	WAYS	-	-	3	
		<i>Subtotals</i>	0	3	10	<i>Subtotals</i>	0	6	7	<i>Subtotals</i>	0	0	14
		Total			13	Total			13	Total			14

Total Math & Science Units: 25

Total Engineering Units: 59

Total Other Units: 78

Total Units: 162

Notes:

*Assumes 10 units of AP Calculus credit for Math 41 & 42 and 8 units AP Physics C credit for PHYSICS 41 & 43

CME 100, 102, 104 are also listed as ENGR 154, 155A, and 155B.

AA190 fulfills the Writing in the Major requirement.

Students who test out of the language requirement should replace language units with technical electives.

Aeronautics and Astronautics

Sample Program with Math 40 and Physics 40 Series Start

	<i>Fall</i>				<i>Winter</i>				<i>Spring</i>			
	Class	Math/ Sci	Engr	Other	Class	Math/ Sci	Engr	Other	Class	Math/ Sci	Engr	Other
<i>Freshman</i>	PWR	-	-	4	Sci. Elective	3	-	-	WAYS	-	-	3
	CHEM 31X	5	-	-	PHYSICS 41	4	-	-	ENGR 14	-	4	-
	MATH 41	5	-	-	MATH 42	5	-	-	PHYSICS 43	4	-	-
	Intro Sem	-	-	3	Intro Sem	-	-	3	THINK	-	-	4
	<i>Subtotals</i>	<i>10</i>	<i>0</i>	<i>7</i>	<i>Subtotals</i>	<i>12</i>	<i>0</i>	<i>3</i>	<i>Subtotals</i>	<i>4</i>	<i>4</i>	<i>7</i>
	Total			17	Total			15	Total			15
<i>Sophomore</i>	PWR	-	-	4	Elective	-	-	4	ENGR 15	-	4	-
	PHYSICS 45	4	-	-	CME 102	5	-	-	WAYS	-	-	3
	CME 100	5	-	-	ENGR 30	-	3	-	ME 80	-	4	-
	WAYS	-	-	3	CME 106	4	-	-	ME 70	-	4	-
	<i>Subtotals</i>	<i>9</i>	<i>0</i>	<i>7</i>	<i>Subtotals</i>	<i>9</i>	<i>3</i>	<i>4</i>	<i>Subtotals</i>	<i>0</i>	<i>12</i>	<i>3</i>
	Total			16	Total			16	Total			15
<i>Junior</i>	ME 131A	-	3	-	ENGR 70A	-	5	-	AA 190	-	3	-
	ME 161	-	3	-	Language	-	-	5	Language	-	-	5
	Language	-	-	5	Elective	-	-	4	Engr fund	-	3	-
	AA 100	-	3	-	Depth course	-	3	-	Depth Course	-	3	-
	<i>Subtotals</i>	<i>0</i>	<i>11</i>	<i>5</i>	<i>Subtotals</i>	<i>0</i>	<i>8</i>	<i>9</i>	<i>Subtotals</i>	<i>0</i>	<i>9</i>	<i>5</i>
	Total			15	Total			17	Total			14
<i>Senior</i>	Engr Elective	-	3	-	Engr Elective	-	3	-	Elective	-	-	3
	Depth Course	-	3	-	Depth Course	-	3	-	Elective	-	-	3
	TIS course	-	-	3	Elective	-	-	4	Elective	-	-	4
	Elective	-	-	4	Elective	-	-	4	WAYS	-	-	3
	<i>Subtotals</i>	<i>0</i>	<i>6</i>	<i>7</i>	<i>Subtotals</i>	<i>0</i>	<i>6</i>	<i>8</i>	<i>Subtotals</i>	<i>0</i>	<i>0</i>	<i>13</i>
	Total			13	Total			14	Total			13

Total Math & Science Units: 44

Total Engineering Units: 59

Total Other Units: 78

Total Units: 181

Notes:

CME 100, 102, 104 are also listed as ENGR 154, 155A, and 155B.

AA190 fulfills the Writing in the Major requirement.

Students who test out of the language requirement should replace language units with technical electives.

INSTRUCTIONS FOR DECLARING MAJOR IN ENGINEERING: AERONAUTICS & ASTRONAUTICS

1. Print your Stanford unofficial transcript from Axess.
2. Download the AA Program Sheet from the School of Engineering web site. Complete the Program Sheet indicating how you plan to fulfill the major requirements – or do this when you meet with your advisor. Your program proposal may change as you progress in the program: submit revisions in consultation with your advisor. Submit a final Program Sheet at least two quarters before you graduate.
3. Complete the form below and take it, along with your transcript and Program Sheet, to the Aero/Astro Student Services Manager (Durand Building, room 250) for an academic advisor assignment.
4. Make an appointment with your advisor to discuss your program. Have your advisor sign the Program Sheet and the declaration form.
5. Return the signed forms to the Aero/Astro Student Services Manager.
6. Declare the Aero/Astro major on Axess!

Stanford University ♦ School of Engineering
Aeronautics and Astronautics
2014–2015 Program Sheet

Final version of completed and signed program sheet due to the department one month prior to the last quarter of enrollment.

Follow all requirements as stated for the year of the program sheet used.

Name: _____ SU ID#: _____
 Phone: _____ EMAIL: _____
 Today's Date: _____ Month/Yr B.S. expected: _____

Mathematics and Science Requirements

Dept	Course	Title	Transfer/AP Approval by SoE			Unit	Grade
			✓ if Transfer	SoE Initials	Date		
<i>Mathematics</i>							
MATH	41 & 42	or AP Calculus				10	
CME	100	or Math 51 (req'd) (see Note 1)				5	
CME	102	or Math 53 Ordinary Diff. Eq w/ Lin. Algebra (req'd)				5	
CME	104	or Math 52				5	
CME	106	or Stats 110, Stats 116, CS 109 (req'd)				4-5	

(24 units minimum)

Science

PHYSICS	41	Mechanics (req'd) (see Note 2)				4-5	
PHYSICS	43	Electricity and Magnetism (req'd) (see Note 2)				4-5	
PHYSICS	45	Light & Heat (req'd)				4	
CHEM	31X	or Engr 31, or Chem 31A+B, or AP Chemistry (req'd)				4-5	
		Science elective from SoE approved list: See UGHB, Fig 3-2 (req'd)				3-5	

Science (19 units minimum)

Mathematics and Science (43 units minimum)

Technology in Society Requirement (1 course required; see note 3)

						3-5	
--	--	--	--	--	--	-----	--

NOTES

- * All courses taken for the major must be taken for a letter grade if that option is offered by the instructor.
 - * This form is available as an Excel file at <http://ughb.stanford.edu/>; you must use a program sheet from a year you are enrolled at Stanford. The printed form must be signed by the advisor and, if required, by the departmental representative.
 - * Read all emails from your department; this is the School's method of communicating key information to ENGR majors.
 - * Minimum Combined GPA for all courses in Engineering Topics (Engineering Fundamentals and Depth courses) is 2.0.
 - * Transfer and AP credits in Math, Science, Fundamentals, & TIS must be approved by the SoE Dean's office. Transfer credits in Engineering Depth must be approved by the advisor and department. Transfer credit information and petitions are available at <http://ughb.stanford.edu/transfer.html>.
 - * All courses listed on this form must only be included under one category. Delete courses not taken.
- (1) It is strongly recommended that the CME series (100, 102, 104) be taken rather than the MATH series (51, 52, 53). If you are taking the MATH series, it is strongly recommended to take CME 192 or MATH 51M: Introduction to MATLAB.
 - (2) A 4 or 5 on the AP Physics C Mechanics test places the student out of Physics 41. Similarly, a 4 or 5 on the AP Physics Electricity and Magnetism test places the student out of Physics 43.
 - (3) For a list of approved TIS courses, see Figure 3-3 in the UGHB or Approved Courses page on UGHB website.

program sheet continues on page 2

Aeronautics and Astronautics Program Sheet (continued)

Engineering Fundamentals (3 courses required)

Dept	Course	Title	Transfer/AP Approval by SoE			Units	Grade
			✓ if Transfer	SoE Initials	Date		
ENGR	30	Engineering Thermodynamics (req'd)				3	
ENGR	70A	Programming Methodology (req'd) (same as CS 106A)				5	
ENGR		Fundamentals Elective; see UGHB, Fig 3-4 (see note 4)				3-5	
<i>Engineering Fundamentals Unit Total (11 units minimum)</i>							

Engineering Depth

AA	100	Intro to Aeronautics & Astronautics (req'd)				3	
AA	190	Dir Rsch & Writing in AeroAstro (req'd) (WIM)				3-5	
ME	70	Introductory Fluids Engineering (req'd)				4	
ME	131A	Heat Transfer (req'd)				3	
ENGR	14	Introduction to Solid Mechanics (req'd)				4	
ENGR	15	Dynamics (req'd)				4	
ME 161 or PHYS 110		Dynamic Systems (3 units) or Advanced Mechanics (one req'd)				3-4	
CEE 101A or ME 80		Mechanics of Materials (one req'd)				4	

Aero/Astro Depth

Engineering Electives (2 courses required, see UGHB, Fig AA-1 under Aero/Astro Requirements)

		Engineering Elective (see Note 5)				3-5	
		Engineering Elective (see Note 5)				3-5	

Depth Area I Dyn/Ctrl Systems Design Fluids/CFD Structures (check 1)

		depth course				3-5	
		depth course				3-5	

Depth Area II Dyn/Ctrl Systems Design Fluids/CFD Structures (check 1)

		depth course				3-5	
		depth course				3-5	

Engineering Depth Unit Totals (47 units minimum)

Program Totals

<i>Mathematics and Science (43 units minimum)</i>	
<i>Technology in Society (3 units minimum)</i>	
<i>Engineering Topics (Fundamentals + Depth) (57 units minimum)</i>	

Program Approvals

Advisor

Printed Name: _____
Signature: _____

Date: _____

Departmental

Printed Name: _____
Signature: _____

Date: _____

School of Engineering (Signature not necessary for graduation)

Printed Name: _____
Signature: _____

Date: _____

NOTES

- (4) ENGR 70B or X (same as CS 106B or X) not allowed to fulfill the third fundamentals requirement.
- (5) See UGHB, Fig AA-1. Additional courses from Depth Area Options (UGHB, Fig AA-2) will also fulfill this requirement.

ARCHITECTURAL DESIGN

The Architectural Design major seeks to integrate engineering and architecture in ways that blend innovative architectural design with cutting-edge engineering technologies. Combining hands-on architectural design studios with a wide variety of courses, students can choose from a broad mix of elective courses in energy conservation, sustainability, building systems, structures, as well as design foundation and fine arts courses.

In addition to preparing students for advanced studies in architecture and construction management, the program's strong math and science requirements prepare students well for graduate work in other fields, such as civil and environmental engineering, law, and business. The major provides a background for individuals wanting to explore a diversity of careers in architecture, engineering, construction, and structures.

This undergraduate major grants a degree of Bachelor of Science in Engineering with a specialization in Architectural Design. This engineering major is not an ABET-accredited engineering degree, nor is it designed to lead directly to professional licensure in architecture. In order to become a professional architect or engineer, additional graduate training is required.

The program's courses also benefit Civil Engineering majors who want to develop a "concentration" in architecture. In addition, for students majoring in related fields such as Urban Studies, Product Design, and Studio Arts, the course offerings in architecture and engineering can be used to fulfill the requirements for a minor in the Department of Civil and Environmental Engineering.

REQUIREMENTS

A total of 100 units are required, distributed as follows.

Mathematics and Science (36 units minimum), including

MATH 19, 20, 21 (or 41 & 42)

One course in Statistics required (see Chapter 3, Fig. 3-1 for list of approved courses)

PHYSICS 41.Mechanics (required)

For other courses, choose from the School of Engineering approved list of math and science courses (listed in this handbook [Fig. 3-1 and 3-2] and online at <http://ughb.stanford.edu>), and the following lists of additional approved *or* recommended courses for the major.

Specially approved science courses for the AD Major

- EARTHSYS 101. Energy and the Environment
- EARTHSYS 102. Renewable Energy Sources and Greener Energy Processes

Recommended math and science courses for the AD Major

- CEE 101D*. Mathematical Laboratory Applications in CEE Engineering
- CME 100. Vector Calculus for Engineers
- CEE 64. Air Pollution: Urban Smog to Global Change
- CEE 70* (same as ENGR 90). Environmental Science and Technology
- GES 1A or 1B or 1C. Dynamic Earth: Fundamentals of Earth Science
- PHYSICS 23 or 43. Electricity

* Courses used for the Science requirement may not also be counted for Fundamental or Depth/Core requirements.

Technology in Society

One course required. Choose from the approved list of courses in this handbook (Chapter 3, Figure 3-3).

Engineering Fundamentals and Depth

60 units minimum required from Engineering Fundamentals; Required Depth Core, Options; and Electives

ENGINEERING FUNDAMENTALS: THREE COURSES REQUIRED

Course	Title	Qtr	Units
ENGR 14	Introduction to Solid Mechanics (req'd)	A, W, S	4
CEE 146A* or ENGR 60	Engineering Economy (req'd)	W Sum	3 3
	Fundamentals Elective (see Figure 3-4 in Chapter 3)		3-5

*CEE 146A may be used to fulfill the Engineering Fundamentals requirement only for AD majors

REQUIRED DEPTH CORE

Course	Title	Qtr	Units
CEE 31 or 31Q	Accessing Architecture Through Drawing	A, W, S	4
CEE 100	Managing Sustainable Building Projects; <i>fulfills writing in major (WIM)</i>	A	4
CEE 120	Building Information Modeling	A, W, S	4
CEE 130	Architectural Design: 3-D Modeling, Methodology, and Process	A, W	4
CEE 137B or other in 137 series	Advanced Architecture Studio	S	5
ARTHIST 3	Introduction to the History of Architecture	S	5

DEPTH OPTIONS (12 UNITS MINIMUM)

Choose 12 units from CEE 101A, 101B, 101C, 156, 172, 172A, 176A, 180, 181, 182, 183, 226, 241, or 242.

DEPTH ELECTIVE COURSES

At least one of the following courses:

CEE 32A	Psychology of Architecture	Not given 2014-15	3
CEE 32B	Design Theory	Not given 2014-15	4
CEE 32D	Construction: The Writing of Architecture	Not given 2014-15	3
CEE 32F	Light, Color and Space	Not given 2014-15	3
CEE 32G	Architecture Since 1900	A	4
CEE 32Q	Place: Making Space Now	W	3
CEE 131A	Professional Practice	W	3
CEE 139	Design Portfolio Methods	W	2

PLUS ADDITIONAL UNITS FROM THE FOLLOWING TWO PAGES TO BRING FUNDAMENTAL + DEPTH TOTAL TO AT LEAST 60 UNITS.

ENGR Electives	Title	Qtr	Units
CEE 32A	Psychology of Architecture	Not given 2014-15	3
CEE 32B	Design Theory	Not given 2014-15	4
CEE 32D	Construction: The Writing of Architecture	Not given 2014-15	3
CEE 32F	Light, Color and Space	Not given 2014-15	3
CEE 32G	Architecture Since 1900	A	4
CEE 32Q	Place: Making Space Now (not given 2014-15)	W	3
CEE 101B	Mechanics of Fluids	S	4
CEE 101C	Geotechnical Engineering	A	3-4
CEE 120A, B	Building Modeling Workshop	A, S	4
CEE 120C	Building Systems Integration	W	4
CEE 122A,B	Computer Integrated Architecture/Engr./Construction	W, S	3,2
CEE 124	Sustainable Development Studio	A,W,S	1-5
CEE 131A	Professional Practice	W	3
CEE 132	Interplay of Architecture and Engineering	Not given 2014-15	4
CEE 134B	Intermediate Architectural Studio	A,W	4
CEE 135	Parametric Modeling and Optimization	Not given 2014-15	4
CEE 139	Design Portfolio Methods	W	2
CEE 154	Cases in Estimating Costs	Not given 2014-15	3
CEE 172A	Indoor Air Quality	S	2-3
CEE 176A	Energy Efficient Buildings	W	3-4
CEE 180	Structural Analysis	A	4
CEE 181	Design of Steel Structures	A	4
CEE 182	Design Experience – Steel Structures	W	3-4
CEE 183	Integrated Building Design	S	4
ENGR 50	Introductory Science of Materials	A, W, S	4
ENGR 103	Public Speaking	A, W, S	3
ENGR 131	Ethical Issues in Engineering	A,S	4
ME 10AX	Design Thinking and the Art of Innovation	Sum	2
ME 101	Visual Thinking	A, W, S	4
ME 110	Design Sketching	A, W, S	1
ME 115A	Introduction to Human Values in Design	A	3
ME 115B	Product Design Methods	W	3

ME 115C	Design and Business Factors	S	3
ME 120	History and Philosophy of Design	S	3
ENGR Electives (cont)	Title	Qtr	Units
ME 203	Design and Manufacturing	A, W, S	4
ME 222	Beyond Green Theory: Workshop in Ecological Design	Not given 2014-15	2-3

Non-ENGR Electives	Title	Qtr	Units
ARTHIST 107A	St. Petersburg, a Cultural Biography: Architecture, Urban Planning, the Arts	Not given 2014-15	4
ARTHIST 142	Varieties of Modern Architecture	S	4
ARTHIST 143A	American Architecture	Not given 2014-15	4
ARTHIST 188A	The History of Modern and Contemporary Japanese and Chinese Architecture and Urbanism	Not given 2014-15	4
ARTSTUDI 13BX	Painting for Non-Majors	Not given 2014-15	2
ARTSTUDI 140	Drawing I	A,W,S	3
ARTSTUDI 145	Painting I	A,W,S	3
ARTSTUDI 147	Artist's Book	W	4
ARTSTUDI 151	Sculpture I	A,W	4
ARTSTUDI 160	Design I: Fundamental Visual Language	A,W	3-4
ARTSTUDI 170	Introduction to Photography	A,W,S	4
ARTSTUDI 171	Introduction to Digital Photography	A	3
ARTSTUDI 180	Color	Not given 2014-15	3-4
ARTSTUDI 262	The Chair	S	3-4
TAPS 137	Hand Drafting for Designers	Not given 2014-15	3
FILMPROD 114	Introduction to Film and Video Production	A,S	5
URBANST 110	Utopia and Reality: Introduction to Urban Studies	A,S	4
URBANST 113	Introduction to Urban Design: Contemporary Urban Design in Theory and Practice	W	5
URBANST 163	Land Use Control	Not given 2014-15	4
URBANST 171	Urban Design Studio	S	5

SUGGESTED COURSE CONCENTRATIONS AND SEQUENCES

Subject to the requirements outlined above, students have considerable leeway in choosing their depth electives and other courses to best suit their background and interests. By careful selection of technically-oriented depth electives, students can complement their studio experience with courses in structural analysis, construction, cost estimating, and energy efficiency.

Students intent on applying to architecture graduate school are encouraged to take studio art courses as early as possible in their academic career and to take more than the required number of architecture studios. In preparation for architecture graduate school applications, students should plan on taking the portfolio preparation class (CEE 139). It is also recommended that students take computer modeling courses which will enable them to pursue summer internships. Internships are valuable since they allow students to test their interest in architecture as a profession.

Architectural Design

Typical Sequence of Courses

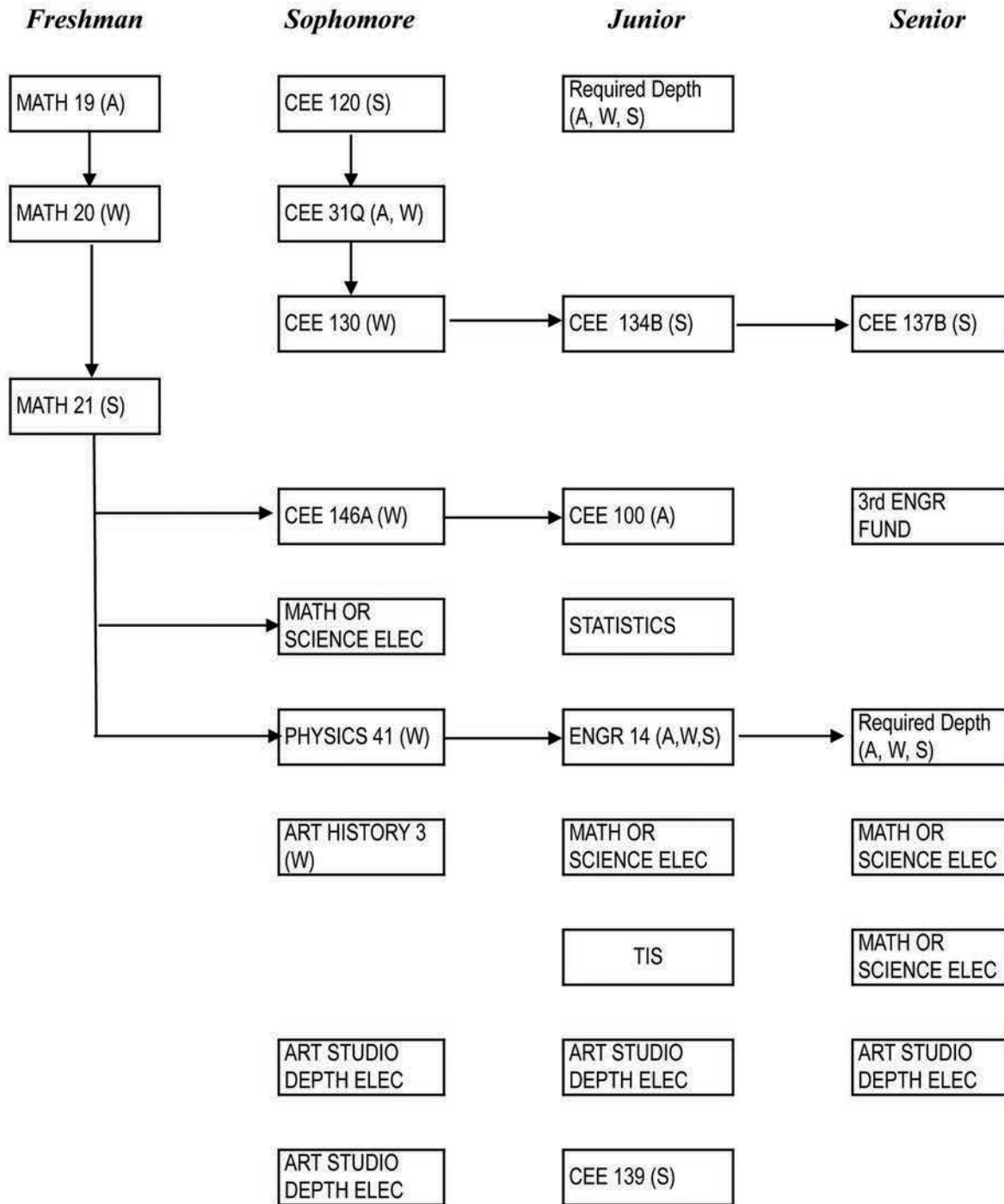

*Arrows represent direct prerequisites

The number of departmental electives must be such that courses in Engineering Fundamentals, Required Depth, and Depth Electives total at least 60 units

Architectural Design

Typical 4-Year Plan

	<i>Fall</i>				<i>Winter</i>				<i>Spring</i>			
	Math/				Math/				Math/			
	Class	Sci	Engr	Other	Class	Sci	Engr	Other	Class	Sci	Engr	Other
<i>Freshman</i>	MATH 19	3			MATH 20	3			MATH 21	4		
	THINK			4	IntroSem			4	WAYS			4
	CEE 63	3			GER			3	Writing			4
	GER			3	STAT 60	5						
	<i>Subtotals</i>	6	0	7	<i>Subtotals</i>	8	0	7	<i>Subtotals</i>	4	0	8
	Total			13	Total			15	Total			12
<i>Sophomore</i>	MATH 51	5			PHYSICS 41	4			ENGR 14			4
	CEE 100*		4		CEE 146A		3		CEE 120		4	
	CEE 31		4		CEE130		4		Art Studio			4
					ARTHIST 3		5		Writing			4
	<i>Subtotals</i>	5	8	0	<i>Subtotals</i>	4	12	0	<i>Subtotals</i>	0	8	8
	Total			13	Total			16	Total			16
<i>Junior</i>	Language			4	Language			5	Language			4
	TIS			4	Required Depth		4		Required Depth		4	
	Math/Sci Elctv	5			Depth Elctv+		4		Science Elctv	4		
	Unrstr Elctv			3	Unrstr Elctv			3	Depth Elctv+		4	
	<i>Subtotals</i>	5	0	11	<i>Subtotals</i>	0	8	8	<i>Subtotals</i>	4	8	4
	Total			16	Total			16	Total			16
<i>Senior</i>	Science Elctv	4			Required Depth		4		Science Elctv	4		
	Depth Elctv+		4		Unrstr Elctv			5	CEE 137B		5	
	Unrstr Elctv			4	Funds Elctv		3		Elctv Studio		4	
	GER			5	Unrstr Elctv			5				
	<i>Subtotals</i>	4	4	9	<i>Subtotals</i>	0	7	10	<i>Subtotals</i>	4	9	0
	Total			17	Total			17	Total			13

Total Math & Science Units: 44
 Total Engineering Units: 64
 Total Other Units: 72
Total Units: 180

Notes:

- * CEE 100 fulfills the WIM (writing in the major) requirement.
- + At least 3 units of Depth Electives must be taken from departments within the School of Engineering.
- ➔ The School of ENGR encourages a quarter abroad. For detail on in-person or online ENGR course options see the Overseas Programs & Engineers page on the UGHB website or Chap 8 of the UGHB.

Architectural Design

4-Year Plan with AP Calculus

	<i>Fall</i>				<i>Winter</i>				<i>Spring</i>			
	Math/ Sci	Engr	Other		Math/ Sci	Engr	Other		Math/ Sci	Engr	Other	
<i>Freshman</i>	EARTHSYS10		4		STATS	5			PHYSICS 43	4		
	THINK			4	IntroSem			4	GER		4	
	MATH 51	5			Physics 41	4			Writing		4	
	<i>Subtotals</i>	5	0	8	<i>Subtotals</i>	9	0	4	<i>Subtotals</i>	4	0	8
	Total			13	Total			13	Total			12
<i>Sophomore</i>	Language			4	Language			4	Language		5	
	CEE 100*		4		CEE 146A		3		CEE 110	4		
	CEE 31		4		CEE130		4		Art Studio	3		
	GER			4	ARTHIST 3		5		Writing		4	
<i>Subtotals</i>	0	8	8	<i>Subtotals</i>	0	12	4	<i>Subtotals</i>	0	7	9	
	Total			16	Total			16	Total			16
<i>Junior</i>	TIS			4	Unrstr Elctv			4	ENGR 14		4	
	WAYS			4	CEE 136		4		CEE 156	4		
	ARTSTUDI			5	Depth Elctv+		4		CEE 131A	3		
	Unrstr Elctv			4	Funds Elctv		3		Depth Elctv+	4		
<i>Subtotals</i>	0	0	17	<i>Subtotals</i>	0	11	4	<i>Subtotals</i>	0	15	0	
	Total			17	Total			15	Total			15
<i>Senior</i>	Science Elctv	4			CEE 101A		4		Science Elctv	4		
	Depth Elctv+		4		Unrstr Elctv			5	CEE 137B		5	
	Unrstr Elctv			4	Elective		3		Elctv Studio		5	
	GER			5	Unrstr Elctv			4				
<i>Subtotals</i>	4	4	9	<i>Subtotals</i>	0	7	9	<i>Subtotals</i>	4	10	0	
	Total			17	Total			16	Total			14

Total Math & Science Units: 26
 Total Engineering Units: 74
 Total Other Units: 80
Total Units: 180

Notes:

- * CEE 100 fulfills the WIM (writing in the major) requirement.
- + At least 3 units of Depth Electives must be taken from departments within the School of Engineering.
- ➔ The School of ENGR encourages a quarter abroad. For detail on in-person or online ENGR course options see the Overseas Programs & Engineers page on the UGHB website or Chap 8 of the UGHB.

INSTRUCTIONS FOR DECLARING MAJOR IN ENGINEERING: ARCHITECTURAL DESIGN (ENGR-BS)

1. Print your unofficial Stanford transcript from Axess and download the Architectural Design (AD) program sheet from the Undergrad Handbook site **ughb@stanford.edu**.
2. Complete the AD program sheet, indicating how you plan to fulfill the major requirements and which electives you plan to take. Fill in every course you intend to take as well as courses you have already taken for your major. Please include full titles of the classes. Refer to the UGHB for approved math, science, Engineering Fundamental, and TIS courses (pages 17-21) Complete as much of the program sheet as possible on your own.
3. Locate your freshman advising folder and declare on Axess; use Engineering as your plan and Architectural Design as your subplan.
4. Make an appointment with Program Director John Barton (Y2E2 Bldg., Room 267), bringing your SU transcript and program sheet to the meeting. Review your program sheet and clarify questions regarding your academic plan.
5. Jill Filice will email you when you can go on Axess and declare online.
6. If your program sheet changes as you progress in the program, you should submit revisions in consultation with your advisor. Note that any deviations from the approved program need to be petitioned; see below. Submit a final program sheet at the beginning of the quarter you plan to graduate.

Other information:

Procedures for requesting transfer credits and program deviations are described in detail in Chapter 4 - "Policies and Procedures." The relevant forms are in the back of the Handbook in the "Forms" section, or on the UGHB site under the "Petitions" link. The online forms may be filled out electronically. If you are requesting transfer credits or program deviations for the Depth portion of your program, you should bring a copy of your completed petition form and your unofficial transcript to the CEE Student Services office; obtain your program sheet from your file and attach to your other forms for processing.

Note: The online version of your major (link from the Home or Major Programs page of the UGHB website) is considered the definitive version of 2014-15 requirements; corrections or updates may have been made after the printed and pdf versions were published in August 2014.

★ You must use a program sheet from a year you have been enrolled at Stanford.

Engineering Fundamentals (3 courses required)

ENGR	14	Introduction to Solid Mechanics				4	
CEE	146A	Engineering Economy (req'd; see Note 4)				3	
		<i>Fundamentals Elective</i>					
<i>Engineering Fundamentals Total (3 courses required)</i>							

Required Depth Core & Options (38 units minimum)

Dept	Course	Title	Transfer/Deviation Approval by Dept		Units	Grade	
			✓ if Transfer	Dept Initials			Date
Core (22 units required)							
CEE	31(Q)	Accessing Architecture Through Drawing			4		
CEE	100	Managing Sustainable Building Projects (WIM)			4		
CEE	120	Building Information Modeling			4		
CEE	130	Architectural Design			4		
CEE	137B	Advanced Architectural Studio			5		
ARTHIST	3	Introduction to the History of Architecture			5		
Depth Options (12 units minimum; see Note 5 for course list)							
<i>Required Depth Total (38 units required)</i>							

Depth Electives (See Note 6) (Elective units must be such that courses in Engr Fundamentals, Core, Depth Options, and Depth Electives total at least 60 units.)

Depth Total

Fundamentals + Depth Total (60 units minimum)

Program Totals

Mathematics/Science (36 units minimum) + TiS
Engineering Fundamentals Units (3 courses required)
Required Depth (38 units minimum) + Depth Elective Units
Program Unit Total (100 units minimum)

NOTES continued

- (4) CEE 146A allowed as an ENGR Fund for AD majors only. Can also use ENGR 60, offered summer qtr only.
- (5) Depth Options (12 units minimum): CEE 101A, 101B, 101C, 156, 172, 172A, 176A, 180, 181, 182, 183, 226, 241, or 242. Investigate any prerequisites for the listed courses & plan course sequences with the AD director.
- (6) At least one of the following must be taken as a Depth elective: CEE 131A, CEE 139, or any CEE 32-series course.

Program Approvals

Advisor

Printed Name: _____
 Signature: _____

Date: _____

Departmental

Printed Name: _____
 Signature: _____

Date: _____

School of Engineering (No action required – office use only)

Printed Name: _____
 Signature: _____

Date: _____

ATMOSPHERE/ENERGY

Atmosphere and energy are strongly linked: fossil-fuel energy use contributes to air pollution, global warming, and weather modification; and changes in the atmosphere feed back to renewable energy resources, including wind, solar, hydroelectric, and wave resources. Because atmospheric problems can be mitigated by increasing energy efficiency, developing new energy technologies, and shifting to less-polluting energy sources, and because it is important to study the climate, air pollution, and weather impacts of new energy technologies, the two areas, atmosphere and energy, are naturally coupled together.

The Atmosphere/Energy (A/E) undergraduate curriculum prepares undergraduates for an A/E master's degree program, as well as careers in industry, research, consulting, government, non-governmental organizations, and academia. The A/E degree is *NOT* an ABET-accredited degree, as ABET accreditation is advantageous only for obtaining specific jobs that do not overlap with those that students obtaining the A/E degree would generally consider. The degree is accredited as part of Stanford's accreditation through the Western Association of Schools and Colleges (WASC).

A/E students take classes in both Atmosphere and Energy, as well as classes that integrate the two. The curriculum is flexible in that students more interested in one field or the other can take most of their Engineering Depth classes in the area of their choice. Similarly, students desiring to focus more on technology or on science can take the appropriate Depth classes to suit their interest.

Qualified students may also apply to engage in the A/E Honors program (see Chapter 6).

REQUIREMENTS

A total of 101 units are required, distributed as follows:
MATHEMATICS AND SCIENCE (45 UNITS MINIMUM)

Mathematics (23 units minimum, including at least one class from each group):

Group A; Choose one:			
MATH 53	Ordinary Differential Equations with Linear Algebra	A,W,S	5
CME 102	Ordinary Differential Equations for Engineers	W	2
Group B; Choose one:			
CME 106	Introduction to Probability and Statistics for Engineers	W	4

STATS 60	Introduction to Statistical Methods: Pre-calculus	A,W,S	5
STATS 110	Statistical Methods in Engineering and the Physical Sciences	A	4-5

Science (20 units minimum, including all of the following):

Course	Title	Qtr	Units
PHYSICS 41	Mechanics	W	4
PHYSICS 43 or 45	Electricity & Magnetism <i>OR</i> Light & Heat	S A	4 4
CHEM 31B	Chemical Principles II (or CHEM 31X or ENGR 31)	W	5
CEE 70*	Environmental Science and Technology (same as ENGR 90)	A	3

*Can count as science or fundamental but not both.

Engineering Fundamentals (three courses minimum, including the following):

Course	Title	Qtr	Units
ENGR 25E	Energy: Chem. Transformations for Products, Storage, & Use	W	3
Choose at least one	ENGR 10 ENGR 30 ENGR 60 ENGR 70A (same as CS 106A)	W,S,Sum A,W,Sum Sum A,W,S,Sum	4 3 3 5
Plus a third Fundamentals Elective from above or from list in Figure 3-4 in Chapter 3			3 to 5

Technology in Society (one course)

Course	Title	Qtr	Units
MS&E 197	Ethics and Public Policy (recommended; also fulfills WIM*)	W	5

* The Writing in the Major requirement may also be met by taking MS&E 193 (also fulfills TiS), CEE 100, EARTHYSYS 200, MS&E 152W, HUMBIO 4B, or the combination of 2 units of CEE199 with 1 unit of ENGR 199W.

Engineering Depth (42 units minimum):

Course	Title	Qtr	Units
CEE 64*	Air Pollution & Global Warming: History, Science & Solutions (req'd)*	W	3
CEE 173A	Energy Resources (required)	A	3

*Can count as depth course or science but not both.

At least 34 units from the following, with at least 4 courses from each group:

Group A: Atmosphere			
Course	Title	Qtr	Units
AA 100	Introduction to Aeronautics and Astronautics	A	3
BIO 147	Controlling Climate Change in the 21 st Century (alt. years)	Not given 2014-15	3
CEE 63	Weather and Storms	A	3
CEE 101B <i>OR</i> ME 70	Mechanics of Fluids <i>OR</i> Intro Fluids Engineering	S A,W,S	4 4
CEE 164 <i>OR</i> EESS 146B	Intro to Physical Oceanography <i>OR</i> Atmosphere, Ocean, & Climate Dynamics: Ocean Circ (alt years)	W S	4 3
CEE 172	Air Quality Management	W	3
CEE 172A	Indoor Air Quality (alt years)	S	2-3
CEE 172S	Greenhouse Gas Mitigation	S	1-3
CEE 178	Introduction to Human Exposure Analysis	S	3
EARTHYSYS 37N <i>OR</i> EARTHYSYS 41N	Climate Change: Science & Society (alt. years) The Global Warming Paradox	S A	3 3
EARTHYSYS 57Q	Climate Change from the Past to the Future	W	3

EARTHSYS 111 <i>OR</i> BIO 164	Biology and Global Change <i>OR</i> Biosphere-Atmosphere Interactions (alt. years)	W Not given	4 4
EARTHSYS 142 <i>OR</i> EARTHSYS 144	Remote Sensing of Land <i>OR</i> Fundamentals of Geographic Information Science (GIS)	W A	4 3-4
EARTHSYS 146A	Atmosphere, Ocean, and Climate Dynamics: The Atmospheric Circulation (alt years)	W	3
EARTHSYS 184	Climate and Agriculture (alt. years)	S	3-4
ME 131B	Fluid Mechanics: Compressible Flow & Turbomachinery	W	4
MS&E 92Q	International Environmental Policy	W	3
Group B: Energy			
Course	Title	Qtr	Units
AA 116Q <i>OR</i> EE 152	Electric Automobiles and Aircraft Green Electronics	A A	3 4
CEE 109 <i>OR</i> CEE 136	Creating a Green Student Workforce (alt years) <i>OR</i> Green Architecture (alt years)	W W	2 4
CEE 142A <i>or</i> CEE 156	Negotiating Sustainable Development (alt years) Building Systems	W W	3 4
CEE 176A	Energy Efficient Buildings	W	3-4
CEE 176B	Electric Power: Renewables and Efficiency	S	3-4
CEE 176C	Energy Storage Integration	A	3-4
CEE 176F	Energy Systems Field Trips (Alt. years)	W	1-2
CEE 177S	Design for a Sustainable World	S	1-5
CHEMENG 35N	Renewable Energy for a Sustainable World (alt. years)	A	3
EARTHSYS 101	Energy and the Environment	W	3
EARTHSYS 102	Renewable Energy Sources and Greener Energy Processes	S	3
ECON 17N	Energy, the Environment, and the Economy	W	3
EE 151	Sustainable Energy Systems (alt. years)		3
ENERGY 104	Transition to Sustainable Energy Systems	S	4
MATSCI 156	Solar Cells, Fuel Cells, and Batteries: Materials for the Energy Solution	A	3-4
ME 185	Electric Vehicle Design (alt. years)	S	3
OSPSANTG 31	The Chilean Energy System: 30 Years of Market Reform	Sum	5

SUGGESTED COURSE CONCENTRATIONS AND SEQUENCES

Subject to the requirements outlined above, students have flexibility in selecting their depth electives and other courses to best suit their interests. On the following pages, two suggested programs are outlined, one with an emphasis on energy studies and the other on atmospheric studies. Either approach provides the necessary preparation for the master's degree program in Atmosphere/Energy.

Atmosphere/Energy

Typical Sequence of Courses

Energy Emphasis

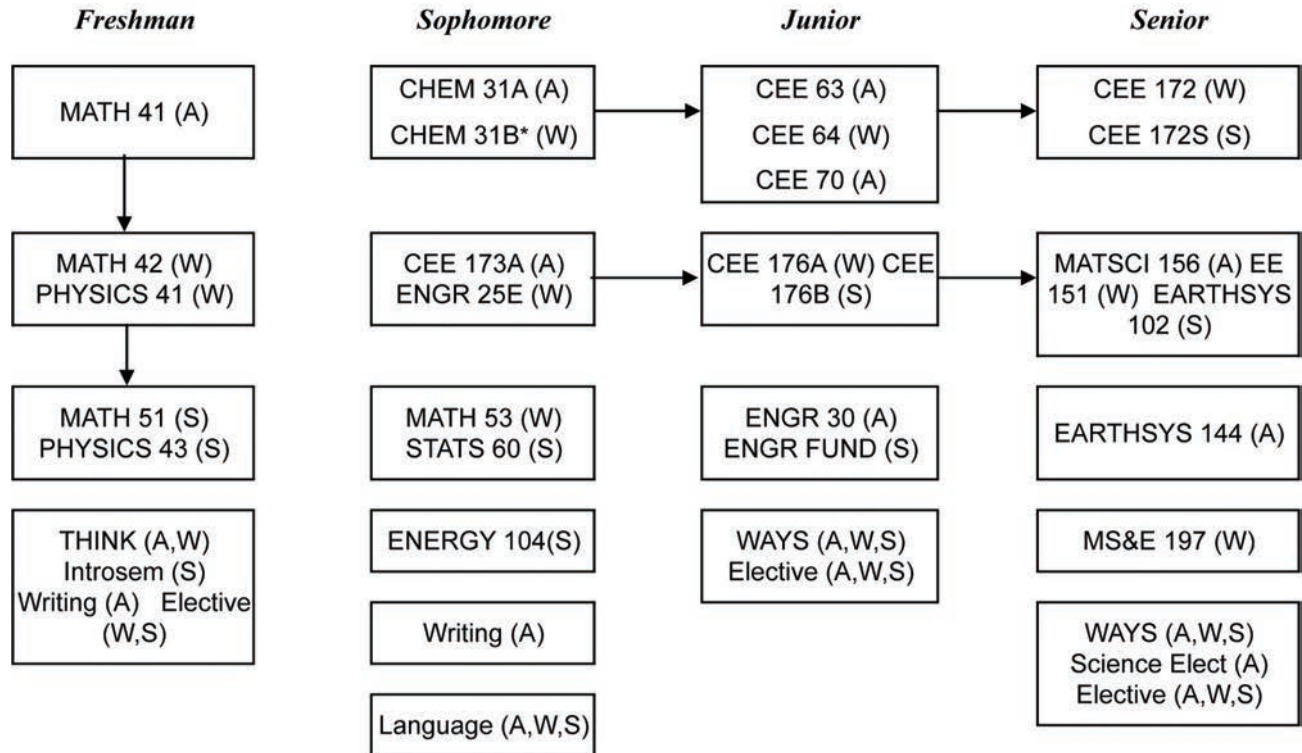

Arrows represent direct prerequisites

* If CHEM 31X is taken, replace CHEM 31B with another science elective.

Atmosphere/Energy

Typical Sequence of Courses
Atmosphere Emphasis

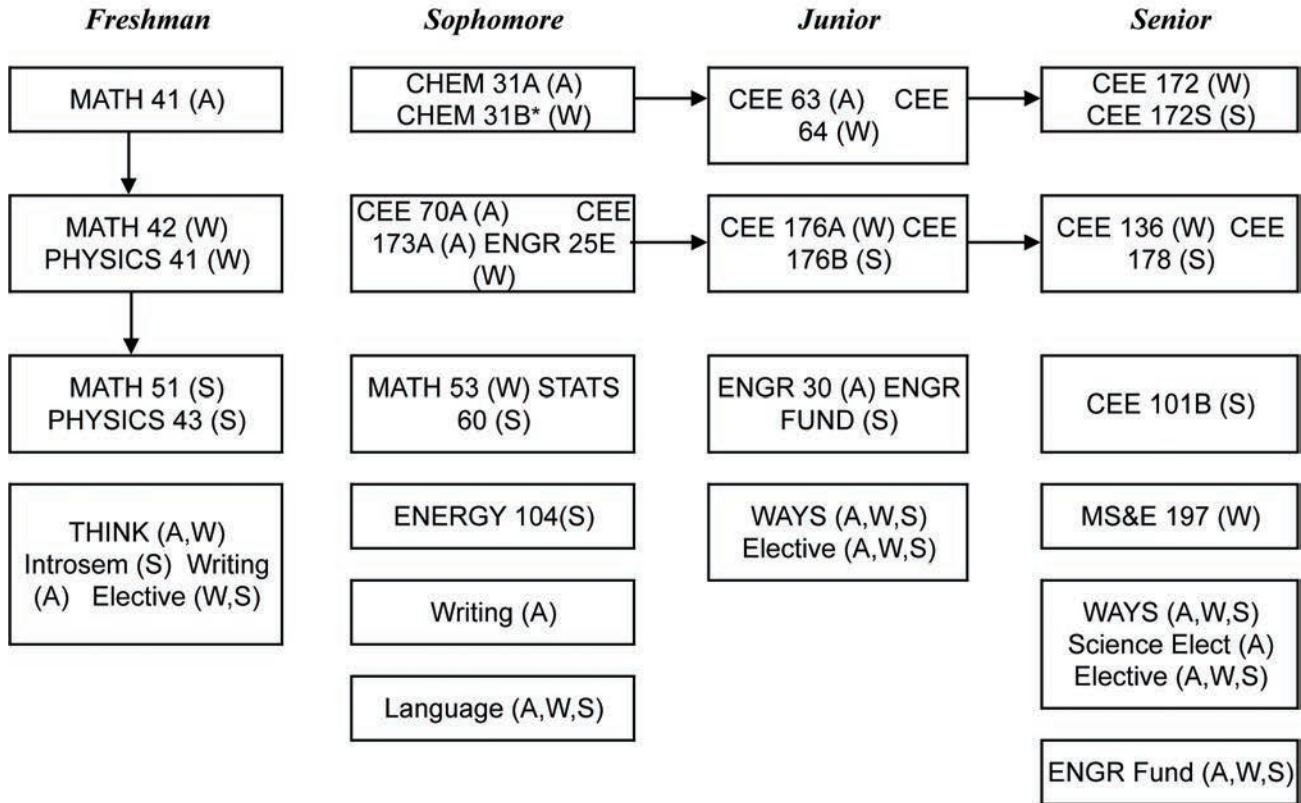

Arrows represent direct prerequisites

* If CHEM 31X is taken, replace CHEM 31B with another science elective.

Atmosphere/Energy Energy Emphasis

Sample 4-Year Plan (starting with Math 41)

	Fall				Winter				Spring			
	Class	Math/ Sci	A/E Depth	Other	Class	Math/ Sci	A/E Depth	Other	Class	Math/ Sci	A/E Depth	Other
<i>Freshman</i>	MATH 41	5			MATH 42	5			MATH 51	5		
	THINK			4	WAYS +			3	Frosh Sem			3
	Elective			5	PWR 1			4	Elective			4
					PHYS 41	4			PHYS 43	4		
	<i>Subtotals</i>	5	0	9	<i>Subtotals</i>	9	0	7	<i>Subtotals</i>	9	0	7
Total			14	Total			16	Total			16	
<i>Sophomore</i>	Language			5	Language			5	Language			5
	Chem 31A#	5			Chem 31B #	5			MATH 53	5		
	CEE 173A		5		PWR 2			4	Elective			3
					ENGR 25E			3	A or E Depth		3	
	<i>Subtotals</i>	5	5	5	<i>Subtotals</i>	5	0	12	<i>Subtotals</i>	5	3	8
Total			15	Total			17	Total			16	
<i>Junior</i>	CEE 63*		3		CEE 176A^		3		CEE 176B^		3	
	CEE 70	3			CEE 64		3		ES 102^		3	
	STATS 60	5			Engr Fund			3	ENGR 10/30/70A			3
	WAYS +			5	WAYS +			5	WAYS +			5
	<i>Subtotals</i>	8	3	5	<i>Subtotals</i>	0	6	8	<i>Subtotals</i>	0	6	8
Total			16	Total			14	Total			14	
<i>Senior</i>	ES 144*		4		CEE 172*		3		CEE 172S*		3	
	MatSci 156^		4		CEE156^		4		ENGY 104^		3	
	WAYS +			4	MS&E 197			5	WAYS +			3
	Elective			3	WAYS +			3	Elective			3
	<i>Subtotals</i>	0	8	7	<i>Subtotals</i>	0	7	8	<i>Subtotals</i>	0	6	6
Total			15	Total			15	Total			12	

Total Math & Science Units (min=45): 46

Total A/E Depth Units (min=42): 44

Total Other Units: 90

Total Units: 180

Notes:

--- Courses in row can be rearranged to accommodate PWR in other quarters.

If Chem 31X or ENGR 31 is taken, replace Chem 31B with a science elective.

* Can be replaced with other Group A (Atmosphere) classes -- minimum of 4 classes needed

^ Can be replaced with other Group B (Energy) classes -- minimum of 4 classes needed

+ May need 7 WAYS courses outside of major reqmts: 2 in Aesthetic/Interpretive Inquiry, 2 in Social Inquiry, 1 in Ethical Reasoning, 1 in Engaging Diversity, and 1 in Creative Expression.

Atmosphere/Energy Atmosphere Emphasis

Sample 4-Year Plan (starting with Math 41)

	<i>Fall</i>				<i>Winter</i>				<i>Spring</i>			
	Class	Math/ Sci	A/E Depth	Other	Class	Math/ Sci	A/E Depth	Other	Class	Math/ Sci	A/E Depth	Other
<i>Freshman</i>	MATH 41	5			MATH 42	5			MATH 51	5		
	THINK			4	WAYS +			4	Frosh Sem.			4
	PWR 1			4	Elective			3	Elective			3
					PHYS 41	4			PHYS 43	4		
	<i>Subtotals</i>	5	0	8	<i>Subtotals</i>	9	0	7	<i>Subtotals</i>	9	0	7
Total			13	Total			16	Total			16	
<i>Sophomore</i>	Language			5	Language			5	Language			5
	Chem 31A #	5			Chem 31B #	5			Elective			4
	PWR 2			4	MATH 53	5			STAT 60	5		
	CEE 70	3			CEE 64		3		A or E Depth		3	
	<i>Subtotals</i>	8	0	9	<i>Subtotals</i>	10	3	5	<i>Subtotals</i>	5	3	9
Total			17	Total			18	Total			17	
<i>Junior</i>	CEE 63*		3		ES 111*		3		CEE 101B*		4	
	CEE 173A		5		CEE 156^		4		ES102^		3	
	WAYS +			4	ENGR 25E			3	ENGR 10/30/70A			3
	Elective			3	WAYS +			5	WAYS +			4
	<i>Subtotals</i>	0	8	7	<i>Subtotals</i>	0	7	8	<i>Subtotals</i>	0	7	7
Total			15	Total			15	Total			14	
<i>Senior</i>	ES144*		3		CEE 172*		3		CEE 172S*		3	
	Engr Fund			3	CEE 176A^		3		CEE 176B^		3	
	WAYS +			4	MS&E 197			5	WAYS +			3
	Elective			3	WAYS +			3	Elective			3
	<i>Subtotals</i>	0	3	10	<i>Subtotals</i>	0	6	8	<i>Subtotals</i>	0	6	6
Total			13	Total			14	Total			12	

Total Math & Science Units (min=45): 46

Total A/E Depth Units (min=42): 43

Total Other Units: 91

Total Units: 180

Notes:

--- Courses in row can be rearranged to accommodate PWR in other quarters.

If Chem 31X or ENGR 31 is taken, replace Chem 31B with a science elective.

* Can be replaced with other Group A (Atmosphere) classes -- minimum of 4 classes needed

^ Can be replaced with other Group B (Energy) classes -- minimum of 4 classes needed

+ May need 7 WAYS courses outside of major reqmts: 2 in Aesthetic/Interpretive Inquiry, 2 in Social Inquiry, 1 in Ethical Reasoning, 1 in Engaging Diversity, and 1 in Creative Expression.

Atmosphere/Energy Energy Emphasis

Sample 4-Year Plan (starting with Math 19)

	<i>Fall</i>				<i>Winter</i>				<i>Spring</i>			
	Class	Math/ Sci	A/E Depth	Other	Class	Math/ Sci	A/E Depth	Other	Class	Math/ Sci	A/E Depth	Other
<i>Freshman</i>	MATH 19	3			MATH 20	3			MATH 21	4		
	THINK			4	WAYS +			5	Frosh Sem			3
	PWR 1			4	Elective			4	WAYS +			4
	Elective			3	Elective			4	Elective			5
	<i>Subtotals</i>	3	0	11	<i>Subtotals</i>	3	0	13	<i>Subtotals</i>	4	0	12
Total			14	Total			16	Total			16	
<i>Sophomore</i>	Language			5	Language			5	Language			5
	MATH 51	5			PHYS 41	4			PHYS 43	4		
	PWR 2			4	WAYS +			4	MATH 53	5		
	Elective			1	A or E Depth		3		Elective			1
	<i>Subtotals</i>	5	0	10	<i>Subtotals</i>	4	3	9	<i>Subtotals</i>	9	0	6
Total			15	Total			16	Total			15	
<i>Junior</i>	CEE 173A		5		CEE 176A [^]		3		ES102 [^]		3	
	CEE 70	3			CEE 64		3		ENGR 10/30/70A			3
	Chem 31A #	5			Chem 31B #	5			STATS 60	5		
	WAYS +			3	ENGR 25E			3	WAYS +			4
	<i>Subtotals</i>	8	5	3	<i>Subtotals</i>	5	6	3	<i>Subtotals</i>	5	3	7
Total			16	Total			14	Total			15	
<i>Senior</i>	ES 144*		4		CEE 172*		3		CEE 172S*		3	
	MatSci 156 [^]		4		CEE156 [^]		4		CEE176B [^]		3	
	Engr Fund			3	MS&E 197			5	ENGY 104 [^]		3	
	CEE 63*		3		WAYS +			4	WAYS +			4
	<i>Subtotals</i>	0	11	3	<i>Subtotals</i>	0	7	9	<i>Subtotals</i>	0	9	4
Total			14	Total			16	Total			13	

Total Math & Science Units (min=45): 46

Total A/E Depth Units (min=42): 44

Total Other Units: 90

Total Units: 180

Notes:

--- Courses in row can be rearranged to accommodate PWR in other quarters.

If Chem 31X or ENGR 31 is taken, replace Chem 31B with a science elective.

* Can be replaced with other Group A (Atmosphere) classes -- minimum of 4 classes needed

[^] Can be replaced with other Group B (Energy) classes -- minimum of 4 classes needed

+ May need 7 WAYS courses outside of major reqmts: 2 in Aesthetic/Interpretive Inquiry, 2 in Social Inquiry, 1 in Ethical Reasoning, 1 in Engaging Diversity, and 1 in Creative Expression.

Atmosphere/Energy Atmosphere Emphasis

Sample 4-Year Plan (starting with Math 19)

	<i>Fall</i>				<i>Winter</i>				<i>Spring</i>				
	Class	Math/ Sci	A/E Depth	Other	Class	Math/ Sci	A/E Depth	Other	Class	Math/ Sci	A/E Depth	Other	
<i>Freshman</i>	MATH 19	3			MATH 20	3			MATH 21	4			
	THINK			4	WAYS +			5	Frosh Sem			4	
	PWR 1			4	Elective			3	WAYS +			3	
	Elective			3	Elective			4	Elective			4	
	<i>Subtotals</i>	3	0		11	<i>Subtotals</i>	3	0		12	<i>Subtotals</i>	4	0
Total				14	Total				15	Total			15
<i>Sophomore</i>	Language			5	Language			5	Language			5	
	MATH 51	5			PHYS 41	4			PHYS 43	4			
	PWR 2			4	WAYS +			4	MATH 53	5			
					CEE 64			3	A or E Depth			3	
	<i>Subtotals</i>	5	0		9	<i>Subtotals</i>	4	3		9	<i>Subtotals</i>	9	3
Total				14	Total				16	Total			17
<i>Junior</i>	CEE 173A			5	CEE 176A [^]			3	CEE 176B [^]			3	
	CEE 70	3			ENGR 25E			3	ENGR 10/30/70A			3	
	Chem 31A #	5			Chem 31B #	5			STATS 60	5			
	WAYS +			3	WAYS +			5	ES 184*			3	
	<i>Subtotals</i>	8	5		3	<i>Subtotals</i>	5	3		8	<i>Subtotals</i>	5	6
Total				16	Total				16	Total			14
<i>Senior</i>	ES 144*			4	CEE 172*			3	CEE 172S*			3	
	CEE 63*			3	ES111*			3	ES 102 [^]			3	
	Engr Fund			3	MS&E 197			5	WAYS +			4	
	WAYS +			5	CEE156 [^]			4	Elective			3	
	<i>Subtotals</i>	0	7		8	<i>Subtotals</i>	0	10		5	<i>Subtotals</i>	0	6
Total				15	Total				15	Total			13

Total Math & Science Units (min=45): 46

Total A/E Depth Units (min=42): 43

Total Other Units: 91

Total Units: 180

Notes:

--- Courses in row can be rearranged to accommodate PWR in other quarters.

If Chem 31X or ENGR 31 is taken, replace Chem 31B with a science elective.

* Can be replaced with other Group A (Atmosphere) classes -- minimum of 4 classes needed

[^] Can be replaced with other Group B (Energy) classes -- minimum of 4 classes needed

+ May need 7 WAYS courses outside of major reqmts: 2 in Aesthetic/Interpretive Inquiry, 2 in Social Inquiry, 1 in Ethical Reasoning, 1 in Engaging Diversity, and 1 in Creative Expression.

INSTRUCTIONS FOR DECLARING MAJOR IN ENGINEERING: ATMOSPHERE/ENERGY (ENGR-BS)

1. Enter your major declaration for Atmosphere/Energy in Axess. Select ENGR-BS as your major and Atmosphere/Energy as your subplan.
2. Pick up your academic folder from your freshman/sophomore adviser and print out your unofficial Stanford transcript from Axess.
3. Download and complete your major Program Sheet, which you can obtain from the UGHB website at <http://ughb.stanford.edu/>. Be sure to fill in all courses that you have taken and those which you plan to take. You will have the opportunity to revise this later, so please fill in as many courses as you can.
4. Bring your academic folder, transcript and completed program sheet to the CEE Student Services office to Room 316 of the Jerry Yang and Akiko Yamazaki Environment & Energy (Y2E2) Building and request to have a CEE advisor assigned to you. You may request a specific advisor if you wish. Office hours are 10-12 and 2- 4, Mon -Fri.
5. Meet with the advisor and have him review and sign your program sheet.
6. Return your signed program sheet to the CEE Student Services Specialist, who will then approve your major declaration in Axess.
7. You are encouraged to meet with your advisor at least once a quarter to review your academic progress. Changes to your program sheet can be made by printing out a revised sheet, obtaining your A/E undergraduate adviser's signature, and returning the approved sheet to the CEE Student Services Office. *NOTE – It is very important to hand in to student services your up-to-date program sheet immediately after the add/drop deadline of the quarter you plan to graduate.*

Other information:

- Procedures for requesting transfer credits and program deviations are described in detail in at the beginning of Chapter 4: "Policies and Procedures." The relevant forms may be downloaded from <http://ughb.stanford.edu> under the "Petitions" link. If you are requesting transfer credits or program deviations, you should bring your completed petition form with your transcript to the CEE Student Services office. Attach your program sheet on file in CEE.
- Check with the CEE Student Services Office to make sure that you are on the CEE undergraduate student email list for important announcements about department events and activities.

Note: The online version of your major (link from the Home or Major Programs page of the UGHB website) is considered the definitive version of 2014-15 requirements; corrections or updates may have been made after the printed and pdf versions were published in August 2014.

★ You must use a program sheet from a year you have been enrolled at Stanford.

Stanford University ♦ School of Engineering
Atmosphere/Energy
2014–2015 Program Sheet

last quarter of senior year.

Follow all requirements as stated for the year of the program sheet used.

Name: _____ SU ID #: _____
 Phone: _____ Email: _____
 Today's Date _____ Mo/Year BS expected: _____

Mathematics and Science Requirements

Dept	Course	Title	Transfer/AP Approval by SoE			Unit	Grade
			✓ if Transfer	SoE Initials	Date		
Mathematics (23 units minimum)							
CME	102	Math/Comp. Methods for Eng. (req'd; see note 1)				5	
CME	106	Statistical Methods (req'd; see note 2)				4	
<i>Mathematics Unit Total (23 units minimum)</i>							
Science (20 units minimum)							
PHYS	41	Mechanics (req'd)				4	
PHYS	43 or 45	Electricity & Magnetism OR Light & Heat (req'd)				4	
CHEM	31B or 31X	Chemical Principles (req'd) (or ENGR 31)				5	
CEE	70	Environmental Science & Technology (req'd)				3	
<i>Science Unit Total (20 units minimum)</i>							
<i>Mathematics and Science (45 units minimum)</i>							

Technology in Society (TiS) Requirement (See note 3)

						3 to 5
--	--	--	--	--	--	--------

NOTES

- * **All courses taken for the major must be taken for a letter grade if that option is offered by the instructor.**
 - * This form is available as an Excel file at <http://ughb.stanford.edu/>; you must use a program sheet from a year you are enrolled at SU. The printed form must be signed by the advisor and, if required, by the departmental representative. Use ink, not pencil, to fill out. Changes must be initialed in ink by your advisor or dept.
 - * Read all emails from your major dept; this is the SoE's only effective method of communicating key information to ENGR
 - * Minimum Grade Point Average (GPA) for all courses in Engineering Fundamentals and AE Depth (combined) is 2.0.
 - * Transfer and AP credits in Math, Science, Funds., & TiS must be approved by the SoE Dean's Office. Transfer credits in Engineering Depth must be approved by the Advisor. Transfer credit information and petitions are available at <http://ughb.stanford.edu/t>
 - * All courses listed on this form must only be included under one category; no double-counting.
- (1) Math 53 may be substituted for CME 102
 - (2) The statistical methods requirement may also be satisfied by taking STATS 60 or STATS 110.
 - (3) To Fulfill the Writing in the Major (WIM) requirement, you may take MS&E 197 (also fulfills TiS), MS&E 193 (also fulfills TiS), CEE 100, EARTHSYS 200, MS&E 152W, HUMBIO 4B, or the combination of 2 units of CEE199 with 1 unit of E199W.

program sheet continues on page 2

Atmosphere/Energy

Engineering Fundamentals (3 courses required)

ENGR	25E	Energy: Chemical Transf. for Prod. Storage, Use				3
ENGR	10,30,60 or 70A	Eng. Analysis, Eng. Thermo., Eng. Economy, or Programming Methodology				3 to 5
		<i>Fundamental Elective (see note 4)</i>				
<i>Engineering Fundamentals Total</i>						

Engineering Depth (42 units minimum; no course listed below may also be listed as fulfilling science or other req't)

Dept	Course	Title	Transfer/Deviation Approval by Dept			Units	Grade
			✓ if Transfer	Dept Initials	Date		
<i>Required:</i>							
CEE	64	Air Pollution: From Urban Smog to Global Change				3	
CEE	173A	Energy Resources				5	

Depth Electives (at least 34 units, 4 courses minimum from each of Groups A and B; see note 4)

Group A: Atmosphere							
Group B: Energy							

Atmosphere/Energy Engineering Depth Total (42 units minimum)

Program Totals

Mathematics and Science (45 units minimum)
Atmosphere/Energy Depth (42 units minimum)

Program Approvals

Advisor

Printed Name: _____ Date: _____
 Signature: _____

Departmental

Printed Name: _____ Date: _____
 Signature: _____

School of Engineering (No action required-office use only)

Printed Name: _____ Date: _____
 Signature: _____

NOTES (continued from page 1)

- (4) If CS 106A is used as Fund #2, CS 106B/X not allowed; ENGR 25B also not allowed.
- (5) Choose at least 4 courses from each of the two groups: Group A (Atmosphere): AA 100; BIO 147; CEE 63; 101B or ME 70; CEE 164 or EESS 146B, CEE 172, 172A, 172S, 178; EARTHSYS 37N or 41N; EARTHSYS 57Q; EARTHSYS 111 or BIO 164; EARTHSYS 142 or 144; EARTHSYS 146A, 184; ME 131B; MS&E 92Q; Group B (Energy): CEE 109 or 136; CEE 142A or 156; CEE 176A, 176B, 176C, 176F, 177S; CHEMENG 35N; EARTHSYS 101, 102; ECON 17N; AA116Q or EE 152; EE 151; ENERGY 104; MATSCI 156; ME 185, OSPSANTG 31

BIOENGINEERING

Understanding and interfacing with complex living systems is at the heart of bioengineering with applications ranging from advancing human health to promoting environmental sustainability. The mission of Stanford's Department of Bioengineering is to create a fusion of engineering and the life sciences that promotes scientific discovery and the development of new biomedical and biological technologies through research and education. The Department of Bioengineering is jointly supported by the Schools of Medicine and Engineering. The Bioengineering (BioE) major enables students to embrace biology as a new engineering paradigm and apply engineering principles to medical problems and biological systems.

Students who major in BioE will obtain a solid background in the basic sciences (chemistry, physics and biology) and mathematics. They will take three engineering fundamentals courses including an introductory bioengineering course and computer programming. Starting in the sophomore year, BioE students will take a series of core classes to gain essential knowledge to pursue a career in bioengineering and will then have the opportunity to pursue elective courses suited to their own interests.

Bioengineering students have a wide variety of options upon graduation. Many will continue on to graduate school or medical school. Others will choose to work in the biotechnology, government service, medical device, medical imaging, or other medical and non-medical industries. Other BioE graduates may choose to pursue advanced degrees in business or law or follow a different career path.

NOTE: Students intending to apply to medical school will need to take additional advanced science courses. While we offer advice regarding pre-med requirements, it is important to schedule an advising appointment with a pre-med advisor in Sweet Hall.

RESEARCH EXPERIENCE FOR UNDERGRADUATES:

Our Research Experience for Undergraduates (REU) program offers Stanford students the opportunity to work closely with a faculty member and their research groups on advanced

research topics during the Summer Quarter. Applications are due early February. Interested students should check the BioE website for announcements.

COMPONENTS OF BIOE:

Math, Science, Engineering Fundamentals, and TIS

All BioE students take courses to get a solid foundation to prepare them for the study of bioengineering. Most of these courses are typically taken during freshman and sophomore year.

These courses include:

MATHEMATICS AND SCIENCE

Course	Title	Units
Math (all courses listed; 28 units minimum)		
MATH 41 & MATH 42	Calculus & Calculus (or AP Calculus)	10
Select one from each category:		
CME 100 or MATH 51	Vector Calculus for Engineers (Recommended) Linear Algebra and Differential Equations	5
CME 102 or MATH 53	Ordinary Differential Equations for Engineers (Recommended) Ordinary Differential Equations with Linear Algebra	5
CME 104 or MATH 52	Linear Algebra & Partial Differential Equations for Engineers (Recomm'd) Integral Calculus of Several Variables	5
CME 106 or STATS 110 or STATS 141	Introduction to Probability and Statistics for Engineering (Recommended) Statistical Methods in Engineering and the Physical Sciences Biostatistics	3-4 4-5 3-5
Science (all courses listed; 28 units minimum)		
CHEM 31X	Chemical Principles (or CHEM 31A and CHEM 31B)	5
CHEM 33	Structure and Reactivity	5
BIO 41	Genetics, Biochemistry, and Molecular Biology	5
BIO 42	Cell Biology and Animal Physiology	5
PHYSICS 41	Mechanics (or AP equivalent)	4
PHYSICS 42	Electricity and Magnetism (or AP equivalent)	4

TECHNOLOGY IN SOCIETY (ONE COURSE):

BIOE 131	Ethics in Bioengineering (satisfies WIM requirement for major)	3
----------	--	---

ENGINEERING FUNDAMENTALS (3 COURSES)

Course	Title	Units
ENGR 80	Introduction to Bioengineering (same as BIOE 80; required)	4
ENGR 70A	Programming Methodology (same as CS 106A; required)	5
Fundamentals Elective; See 3-4 for list of SoE approved course; may not use CS 106B or X for elective.		3-5

Bioengineering Core: All BioE students are required to take a common set of depth courses:

BIOE CORE (36 UNITS; ALL COURSES REQUIRED)

Physical Biology		
Course	Title	Units
BIOE 41	Physical Biology of Macromolecules	4
BIOE 42	Physical Biology of Cells	4

Labs		
Course	Title	Units
BIOE 44	Fundamentals for Engineering Biology Lab	4
BIOE 51	Anatomy for Bioengineers	4
BIOE 123	Optics and Devices Lab	4

Systems Biology & Physiology		
Course	Title	Units
BIOE 101	Systems Biology	4
BIOE 103	Systems Physiology and Design	4

Senior Project		
Course	Title	Units
BIOE 141A	Senior Capstone Design I	4
BIOE 141B	Senior Capstone Design II	4

BioE Depth Electives: Four courses from approved list (minimum of 12 units)		
Course	Title	Units
BIOE 115	Computational Modeling of Microbial Communities	4
BIOE 201C	Diagnostic Devices Lab	3
BIOE 211	Biophysics of Multi-cellular Systems and Amorphous Computing	3
BIOE 212	Introduction to Biomedical Informatics Research Methodology	3
BIOE 214	Representations and Algorithms for Computational Molecular Biology	3-4
BIOE 220	Introduction to Imaging and Image-based Human Anatomy	3-4
BIOE 222	Multimodality Molecular Imaging in Living Subjects I	4
BIOE 223	Physics and Engineering of X-Ray Computed Tomography	3
BIOE 224	Multimodality Molecular Imaging in Living Subjects II	4
BIOE 227	Functional MRI Methods	3
BIOE 231	Protein Engineering	3
BIOE 244	Advanced Frameworks and Approaches for Engineering Integrated Genetic Systems	4
BIOE 260	Tissue Engineering	4
BIOE 281	Biomechanics of Movement	3
BIOE 287	Introduction to Physiology and Biomechanics of Hearing	3
BIOE 291	Principles and Practice of Optogenetics for Optical Control of Biological Tissues	3

Senior Year:

At the end of junior year students who qualify are encouraged to apply for the BioE Honors program (see the Bioengineering honors section in Chapter 6 for details). Students who are accepted spend the senior year exploring a research topic in depth and writing an honors thesis.

Note: The online version of your major (link from the Home or Major Programs page of the UGHB website) is considered the definitive version of 2014-15 requirements; corrections or updates may have been made after the printed and pdf versions were published in August 2014.

★ You must use a program sheet from a year you have been enrolled at Stanford.

Bioengineering

Typical Sequence of Courses
Starting with MATH 40 Series and CHEM 31A

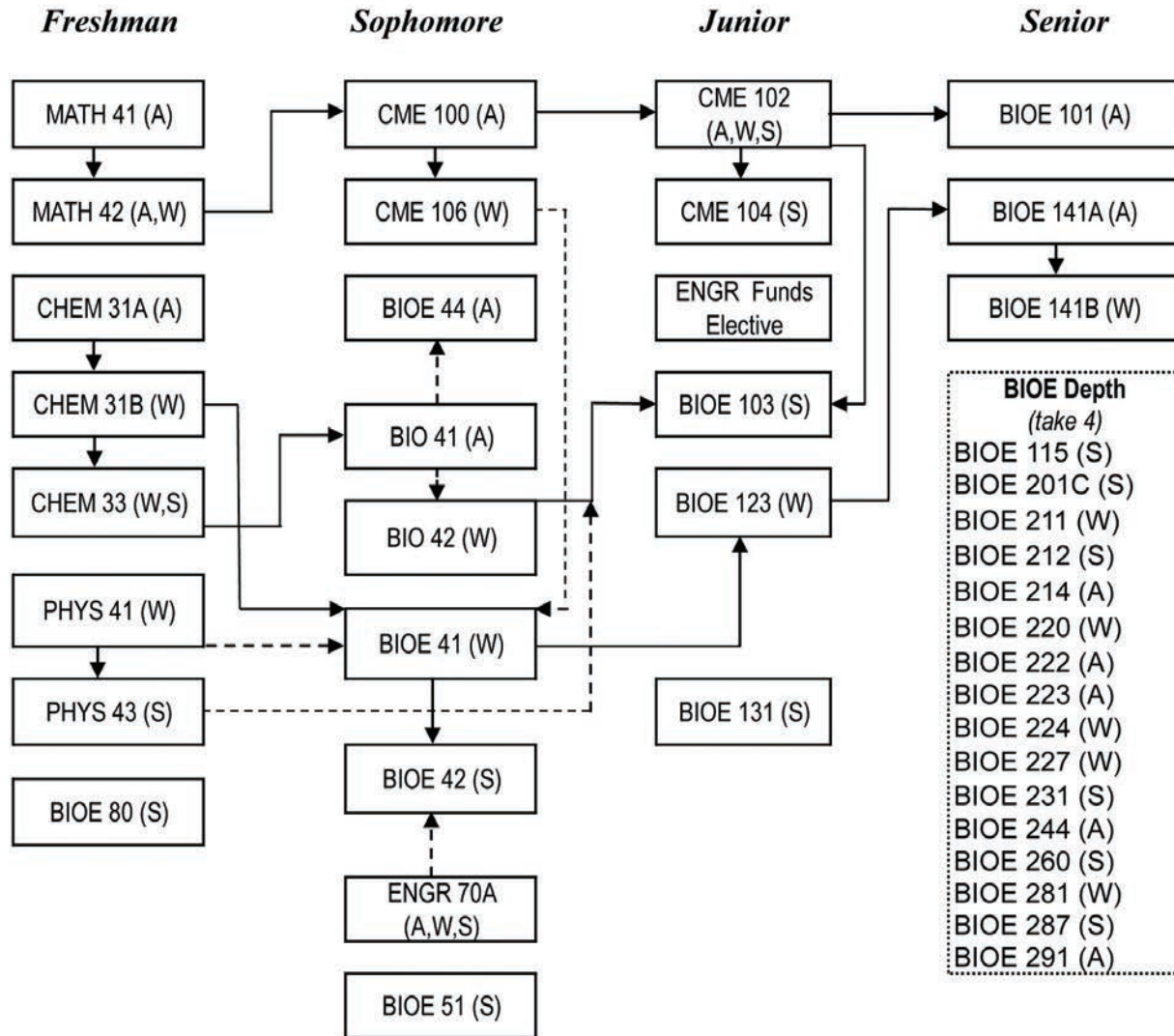

* Arrows represent direct prerequisites

* It is strongly suggested that CME 106 be taken, rather than the STATS courses (110 or 141)

* Dashed-lines represent co-requisites or courses that are strongly recommended.

* Dashed-line box encloses alternatives. These indicate alternate years in which to take a given course, and/or alternate courses that may be taken at a given time.

Bioengineering

Typical Sequence of Courses
Starting with CME 100 and CHEM 31X

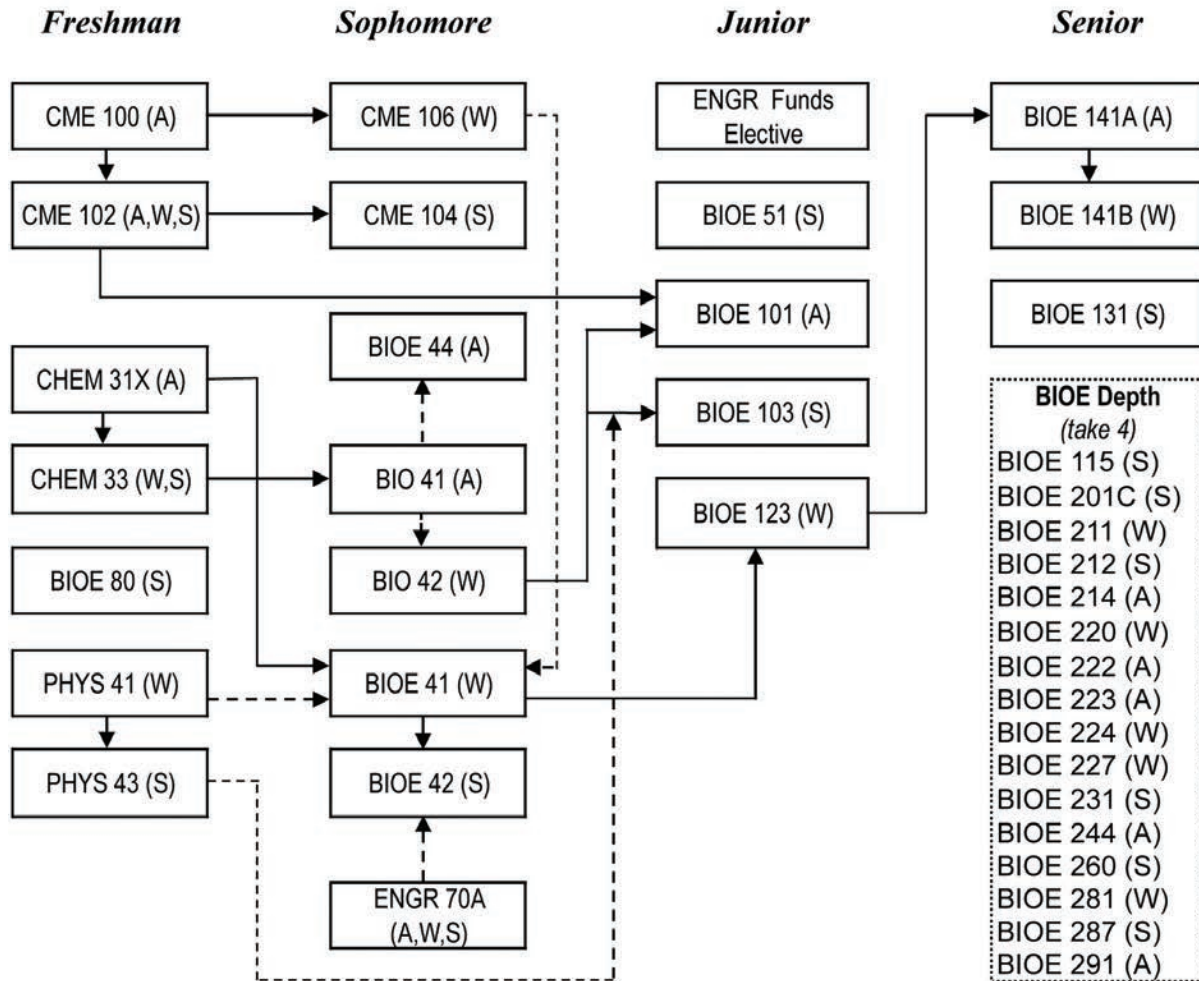

* Arrows represent direct prerequisites

* Dashed-lines represent co-requisites or courses that are strongly recommended.

* It is strongly suggested that CME 106 be taken, rather than the STATS courses (110 or 141)

* Dashed-line box encloses alternatives. These indicate alternate years in which to take a given course, and/or alternate courses that may be taken at a given time.

Bioengineering

4-Year Plan (Starting with Math 41 series and Chem 31A)

	Fall				Winter				Spring			
	Class	Math/ Sci.	Engr	Other	Class	Math/ Sci.	Engr	Other	Class	Math/ Sci.	Engr	Other
<i>Freshman</i>	MATH 41	5			MATH 42	5			CHEM 33	5		
	CHEM 31A	5			CHEM 31B	5			BIOE 80		4	
	THINK			4	PHYS 41	4			PHYS 43	4		
					IntroSem			3	PWR 1			4
	<i>Subtotals</i>	10	0	4	<i>Subtotals</i>	14	0	3	<i>Subtotals</i>	9	4	4
	Total			14	Total			17	Total			17
<i>Sophomore</i>	BIO 41	5			BIO 42	5			BIOE 42		4	
	BIOE 44		4		BIOE 41		4		BIOE 51		4	
	CME 100	5			CME 106	4			PWR 2			4
					ENGR 70A		5		WAYS			3
	<i>Subtotals</i>	10	4	0	<i>Subtotals</i>	9	9	0	<i>Subtotals</i>	0	8	7
	Total			14	Total			18	Total			15
<i>Junior</i>	Engr. Fundament:		4		BIOE 123		4		BIOE 103		4	
	Language			5	CME 102	5			BIOE 131		3	
	WAYS			3	Language			5	CME 104	5		
	WAYS			3					Language			5
	<i>Subtotals</i>	0	4	11	<i>Subtotals</i>	5	4	5	<i>Subtotals</i>	5	7	5
	Total			15	Total			14	Total			17
<i>Senior</i>	BIOE 101		4		BIOE 141B		4		BIOE Depth		4	
	BIOE 141A		4		BIOE Depth		3		BIOE Depth		3	
	BIOE Depth		4		WAYS			3	WAYS			3
					WAYS			4				
	<i>Subtotals</i>	0	12	0	<i>Subtotals</i>	0	7	7	<i>Subtotals</i>	0	7	3
	Total			12	Total			14	Total			10

Total Math & Science Units: 62

Total Engineering Units: 66

Total Other Units: 49

Total Units: 177

➔ The School of ENGR encourages a quarter abroad. For detail on in-person or online ENGR course options see the Overseas Programs & Engineers page on the UGHB website or Chap 8 of the UGHB.

Bioengineering

4-Year Plan (Starting with CME 100 series and CHEM 31X)

	<i>Fall</i>				<i>Winter</i>				<i>Spring</i>			
	Class	Math/ Sci.	Engr	Other	Class	Math/ Sci.	Engr	Other	Class	Math/ Sci.	Engr	Other
<i>Freshman</i>	CME 100	5			CME 102	5			BIOE 80		4	
	CHEM 31X	5			CHEM 33	5			PHYS 43	4		
	PWR 1			4	PHYS 41	4			THINK			4
					IntroSem			3	WAYS			3
	<i>Subtotals</i>	10	0	4	<i>Subtotals</i>	14	0	3	<i>Subtotals</i>	4	4	7
	Total			14	Total			17	Total			15
<i>Sophomore</i>	BIO 41	5			BIO 42	5			BIOE 42		4	
	BIOE 44		4		BIOE 41		4		BIOE 51		4	
	PWR 2			4	CME 106	4			CME 104	5		
					ENGR 70A		5					
	<i>Subtotals</i>	5	4	4	<i>Subtotals</i>	9	9	0	<i>Subtotals</i>	5	8	0
	Total			13	Total			18	Total			13
<i>Junior</i>	BIOE 101		4		BIOE 123		4		BIOE 103		4	
	Engr. Fundament:		4		WAYS			4	WAYS			3
	Language			5	Language			5	Language			5
	WAYS			3								
	<i>Subtotals</i>	0	8	8	<i>Subtotals</i>	0	4	9	<i>Subtotals</i>	0	4	8
	Total			16	Total			13	Total			12
<i>Senior</i>	BIOE 141A		4		BIOE 141B		4		BIOE 131		3	
	BIOE Depth		3		BIOE Depth		4		BIOE Depth		4	
	WAYS			4	WAYS			3	BIOE Depth			3
	<i>Subtotals</i>	0	7	4	<i>Subtotals</i>	0	8	3	<i>Subtotals</i>	0	7	3
	Total			11	Total			11	Total			10

Total Math & Science Units: 47

Total Engineering Units: 63

Total Other Units: 53

Total Units: 163

- The School of ENGR encourages a quarter abroad. For detail on in-person or online ENGR course options see the Overseas Programs & Engineers page on the UGHB website or Chap 8 of the UGHB.

Bioengineering

4-Year Plan (Starting with CME 100 series and CHEM 31 A,B)

	<i>Fall</i>				<i>Winter</i>				<i>Spring</i>			
	Class	Math/ Sci.	Engr	Other	Class	Math/ Sci.	Engr	Other	Class	Math/ Sci.	Engr	Other
<i>Freshman</i>	CME 100	5			CME 102	5			ENGR 80		4	
	CHEM 31A	5			CHEM 31B	5			PHYS 43	4		
	PWR 1			4	PHYS 41	4			CHEM 33			5
	WAYS			3	IntroSem			3	THINK			4
	<i>Subtotals</i>	10	0	7	<i>Subtotals</i>	14	0	3	<i>Subtotals</i>	4	4	9
	Total			17	Total			17	Total			17
<i>Sophomore</i>	BIO 41	5			BIO 42	5			BIOE 42		4	
	BIOE 44		4		BIOE 41		4		BIOE 51		4	
	PWR 2			4	CME 106	4			CME 104	5		
					ENGR 70A		5					
	<i>Subtotals</i>	5	4	4	<i>Subtotals</i>	9	9	0	<i>Subtotals</i>	5	8	0
	Total			13	Total			18	Total			13
<i>Junior</i>	BIOE 101		4		BIOE 123		4		BIOE 103		4	
	Engr. Fundamental		4		WAYS			4	WAYS			3
	Language			5	Language			5	Language			5
	WAYS			3								
	<i>Subtotals</i>	0	8	8	<i>Subtotals</i>	0	4	9	<i>Subtotals</i>	0	4	8
	Total			16	Total			13	Total			12
<i>Senior</i>	BIOE 141A		4		BIOE 141B		4		BIOE 131		3	
	BIOE Depth		3		BIOE Depth		4		BIOE Depth		4	
	WAYS			4	WAYS			3	BIOE Depth			3
	<i>Subtotals</i>	0	7	4	<i>Subtotals</i>	0	8	3	<i>Subtotals</i>	0	7	3
		Total			11	Total			11	Total		

Total Math & Science Units: 47
 Total Engineering Units: 63
 Total Other Units: 58
Total Units: 168

→ The School of ENGR encourages a quarter abroad. For detail on in-person or online ENGR course options see the Overseas Programs & Engineers page on the UGHB website or Chap 8 of the UGHB.

Bioengineering

4-Year Plan (Starting with Chem 31X (or Chem 31 A & B), *Satisfies Premed Requirements)

	Fall				Winter				Spring			
	Math/ Sci.	Engr.	Other		Math/ Sci.	Engr.	Other		Math/ Sci.	Engr.	Other	
Freshman	CME 100	5			CME 102	5			CME 104	5		
	CHEM 31X	4			CHEM 33	4			BIOE 80		4	
	THINK			4	PHYS 41/42	5			PHYS 43/44	5		
	IntroSem			3	PWR 1			4	ENGR 70A		4	
	<i>Subtotals</i>	9	0	7	<i>Subtotals</i>	14	0	4	<i>Subtotals</i>	10	8	0
	Total			16	Total			18	Total			18
Sophomore	BIO 41	5			BIO 42	5			BIO 43	5		
	BIOE 44		4		BIOE 41		4		BIOE 42		4	
	CHEM 35	5			CME 106	4			BIOE 51		4	
	PHYS 45/46	5			PWR 2			4	Engr. Fundamental		4	
	<i>Subtotals</i>	15	4	0	<i>Subtotals</i>	9	4	4	<i>Subtotals</i>	5	12	0
	Total			19	Total			17	Total			17
Junior	BIOE 101		4		BIOE 123		4		BIOE 103		4	
	CHEM 130	3			CHEM 135	3			BIOE 131		3	
	CHEM 131	3			Language			5	Language			5
	Language			5								
	<i>Subtotals</i>	6	4	5	<i>Subtotals</i>	3	4	5	<i>Subtotals</i>	0	7	5
	Total			15	Total			12	Total			12
Senior	BIOE Depth		3		BIOE Depth		4		BIOE Depth		4	
	BIOE 141A		4		BIOE 141B		4		BIOE Depth		3	
	CHEM 181	3			WAYS			3	WAYS			3
	WAYS			3					WAYS			3
	<i>Subtotals</i>	3	7	3	<i>Subtotals</i>	0	8	3	<i>Subtotals</i>	0	7	6
	Total			13	Total			11	Total			13

Total Math & Science Units: 74

Total Engineering Units: 65

Total Other Units: 42

Total Units: 181

→ The School of ENGR encourages a quarter abroad. For detail on in-person or online ENGR course options see the Overseas Programs & Engineers page on the UGHB website or Chap 8 of the UGHB.

INSTRUCTIONS FOR DECLARING MAJOR IN ENGINEERING: BIOENGINEERING (ENGR-BS)

- 1) Log onto Axess and request to major in Bioengineering (select Engineering as your major and BIOE as your subplan).
- 2) Print your unofficial Stanford transcript from Axess.
- 3) Download the ENGR: BIOE Program Sheet from the School of Engineering Handbook web site at <http://ughb.stanford.edu>. You must choose a Program Sheet from a year you were enrolled at Stanford. Enter “AP” instead of a grade for any course waived due to AP credit.
- 4) Design a 4-year plan based on the samples given on previous pages.
- 5) Take your 4-year plan, unofficial transcript and completed BioE Major Declaration Form to the BioE Student Services Office in the Shriram Center, room 119C. The department will assign an advisor to you. The Declaration Form may be found online at <http://bioengineering.stanford.edu/education/declare.html>.
- 6) Meet with your assigned advisor to discuss the program, review your 4-year plan and sign your Program Sheet.
- 7) Return all completed documents to Teri Hankes in the BioE Students Services Office in the Shriram Center, room 119C.
- 8) When your major is approved in Axess, you will be notified via e-mail.

Stanford University ♦ School of Engineering

**Bioengineering
2014-15 Program Sheet**

Final version of completed and signed program due to the department no later than one month prior to the last quarter of senior year.

Follow all requirements as stated for the year of the program sheet used.

Name: _____ SUID#: _____
 Phone: _____ EMAIL: _____
 Today's Date: _____ Month/Year B.S. expected: _____

Dept	Course	Title	Transfer/AP Approval			Units	Grade
			✓ if Transfer	Initials	Date		

Mathematics (28 units minimum required; see UGHB Fig. 3-1 for approved courses)

MATH	41 & 42	or AP Calculus				10	
CME	100	Vector Calculus for Engs (or MATH 51; see Note 1)				5	
CME	102	Ordinary Differential Equations for Engs (or MATH 53; see Note 1)				5	
CME	104	Lin Algebra and Partial Differential Equations for Engrs (or MATH 52; see Note 1)				5	
CME	106	Intro to Probability and Statistics for Engs (or STATS 110/141; see Note 2)				3-5	
<i>Mathematics Total</i>							

Science (28 units minimum required)

CHEM	31	X or A and B required (req'd; see Note 3)				5	
CHEM	33	Structure and Reactivity (req'd)				5	
BIO	41	Genetics, Biochemistry, & Molecular Biology (req'd)				5	
BIO	42	Cell Biology and Animal Physiology (req'd)				5	
PHYS	41	Mechanics (req'd)				4	
PHYS	43	Electricity and Magnetism (req'd)				4	
<i>Science Total</i>							

Technology in Society (1 course required)

BIOE	131	Ethics in Bioengineering (fulfills BioE-specific WIM; req'd)				3	
------	-----	--	--	--	--	---	--

NOTES

- * **All courses listed on this form must be taken for a letter grade if offered by the instructor.**
 - * Minimum GPA for all courses in Engineering Fundamentals and Engineering Depth (combined) is 2.0.
 - * This form is available as an Excel file at ughb.stanford.edu; you must use a program sheet from a year you are enrolled at Stanford. The printed form must be signed by the advisor and, if required, by the departmental representative. Changes must be initialed in ink.
 - * All transfer and AP credits must be approved by the SoE Dean's office. Transfer credits in Engineering Depth must be approved by the major advisor.
 - * Read all emails from your major department; this is the School's only effective method of communicating with you.
- (1) It is strongly suggested that the CME series (100, 102, 104) be taken rather than the MATH series (51, 52, 53). If you are taking the MATH series, it is strongly recommended to take MATH 51M or CME 192: Introduction to MATLAB.
 - (2) CME 106 utilizes MATLAB, a powerful technical computing program, and is the strongly recommended STATS course (rather than options STATS 110 or 141).
 - (3) Science must include both Chemistry (CHEM 31A+B or 31X or ENGR 31) and Physics with two quarters of course work in each and two courses of BIO core. CHEM 31A and B are considered one course even though given over two quarters. Premeds should take Chemistry, not ENGR 31.

Bioengineering Major cont.

Engineering Fundamentals (3 courses required)

ENGR	80	Intro to Bioengineering (same as BIOE 80; req'd)				4
ENGR	70A	Programming Methodology (same as CS 106A; recommended)				5
		Fundamentals Elective; see UGHB for options; CS106 B/X not allowed; see Note 4				
<i>Engineering Fundamentals Total (3 courses required)</i>						

Engineering Depth (36 units; all courses required)

Dept	Course	Title	Transfer/AP Approval			Unit	Grade
			✓ if Transfer	Initials	Date		
BIOE	41	Physical Biology of Macromolecules				4	
BIOE	42	Physical Biology of Cells				4	
BIOE	44	Fundamentals for Engineering Biology Lab				4	
BIOE	51	Anatomy for Bioengineers				4	
BIOE	101	Systems Biology				4	
BIOE	103	Systems Physiology & Design				4	
BIOE	123	Optics and Devices Lab				4	
BIOE	141A	Senior Capstone Design I				4	
BIOE	141B	Senior Captstone Design II				4	
<i>Engineering Depth Total</i>							

BioE Depth Electives (4 courses; minimum 12 units; Premeds see Note 5)

<i>Engineering Courses (Funds + Depth) Total (60 minimum)</i>						
<i>Totals from previous page</i>						
<i>Program Totals</i>						

Advisor

Printed Name: _____ Date: _____

Signature: _____

Department

Printed Name: _____ Date: _____

Signature: _____

School of Engineering Approval (signature not required prior to graduation)

Printed Name: _____ Date: _____

Signature: _____

- (4) If CS 106A is taken as the second Fundamental, neither CS 106B nor X are allowed as the Fundamentals elective.
- (5) Students pursuing a pre-med program will need to take additional courses.

BIOMECHANICAL ENGINEERING

The Biomechanical Engineering major integrates biology and clinical medicine with engineering mechanics and design. Research and teaching in Biomechanical Engineering focuses on biomechanics and mechanobiology at cellular to body length scales, with applications relevant to neuromuscular, musculoskeletal, cardiovascular and cancer physiology and pathology. Research in other areas such as hearing, vision, ocean and plant biomechanics, biomaterials, biosensors, and imaging informatics are also conducted in collaboration with associated faculty in medicine, biology, and engineering.

This degree introduces fundamental biological and biophysical principles while developing strengths in traditional engineering areas, specifically mechanical engineering. Primarily geared toward the students' interests, this major offers a range of courses for students interested in specific fields of biology and mechanical engineering such as design, biomechanics, and medicine.

The Biomechanical Engineering major provides a fundamental understanding of mechanics in the fields of biology and medicine. However, it is not normally recommended as a terminal degree. This major is well suited for those interested in future graduate studies in bioengineering, mechanical engineering, medicine, and related areas. The course of study allows students to satisfy many premedical, pre-dental, or pre-paramedical requirements.

REQUIREMENTS:

Mathematics and Science

Math: The BME major requires a minimum of 43 units of Math and Science combined. At least 21 units of mathematics are required, which **must** include a course in Differential Equations (e.g., CME 102/ENGR 155A or MATH 53 is required). STATS 60 may not be used towards BME requirements, but other statistics courses approved by SoE may be used.

Science: At least 22 units of science are required, which must include both chemistry and physics with a depth (3 quarters) in one. PHYSICS 41 is required. A depth in chemistry can be fulfilled with CHEM 31A/B and CHEM 33 or with CHEM 31X and CHEM 33. CHEM 31X can be replaced with CHEM 31A + 31B or with ENGR 31. Science units must include at least 2 quarters of HUMBIO A/B core or BIO core; students taking HUMBIO must take both A and B sides.

Technology in Society (TIS): One course required

Any course from the SoE approved list may be used (see Ch 3, fig. 3-3).

Writing in the Major (WIM): One course required

There are two options to fulfill the BME WIM requirement: A) Complete ME112, ME131A or ME140. B) Perform engineering research over the summer or during the academic year and enroll in 3 units of ENGR199W “Writing of Original Research for Engineers”, preferably during the time you are performing research, or the following quarter, to write a technical report. This second option requires an agreement with your faculty research supervisor.

Engineering Fundamentals: Three courses required

Course	Title	Units
ENGR 14	Introduction to Solid Mechanics	4
ENGR 25B*	Biotechnology	3
	Fundamental Elective (alternate E25 courses are not allowed)	

*BIOE/ENGR 80 Introduction to Bioengineering may be substituted for ENGR 25B.

Engineering Depth Requirements

The Engineering Depth requirements for the BME major include a core set of introductory mechanical engineering courses, a set of more advanced mechanical engineering courses selected from a prescribed list, and a set of BME depth courses (generally taken during the senior year). BME course offerings vary somewhat year-to-year. As most BME depth courses are intended both for advanced undergraduates and first year graduate students, some courses have implicit expectations for prerequisite knowledge. Students should be aware of expected prerequisites and plan their schedules accordingly. Note that more advanced (300 level) BME courses may be used with permission of the instructor and the student’s advisor.

Mechanical Engineering Core: Five courses

Course	Title	Units
ENGR 15	Dynamics	4
ENGR 30	Engineering Thermodynamics	3
ME 70	Introductory Fluids Engineering	4
ME 80	Mechanics of Materials	4
ME 389*	Biomechanical Research Symposium	1

*If ME 389 is not offered, other options include BIOE 393 or ME 571, or by petition

Mechanical Engineering Depth Electives: Three courses (minimum of 9 units):

Course	Title	Units
ENGR 105	Feedback Control Design	3
ME 101	Visual Thinking	4
ME 112*	Mechanical Systems Design	4
ME 113	Mechanical Engineering Design	4
ME 131A*	Heat Transfer	5
ME 131B	Fluid Mechanics: Compressible Flow and Turbomachinery	4
ME 140*	Advanced Thermal Systems	5
ME 161	Dynamic Systems, Vibrations and Control	3
ME 203**	Design and Manufacturing	4
ME 210	Introduction to Mechatronics	4
ME 220	Introduction to Sensors	3-4

* ME112 or ME131A or ME140 satisfy the WIM requirement.

** BME students are encouraged to take ME 203 in the Winter or Spring quarters.

BME Depth: Three courses (minimum of 9 units) from approved list

Course	Title	Units
BIOE 260	Tissue Engineering	3
ME 239	Mechanics of the Cell	3
ME 266	Introduction to Physiology and Biomechanics of Hearing	3
ME 280	Skeletal Development and Evolution	3
ME 281	Biomechanics of Movement	3
ME 283	Introduction to Biomechanics	3
ME 287	Mechanics of Biological Tissues	3
ME 294L*	Medical Device Design Lab	3
ME 328**	Medical Robotics	3
ME 3XX	Graduate-level biomechanics courses may be used towards the BME depth with permission of instructor and approval from the major advisor.	

*Must be taken in conjunction with ME 294 (1 unit); prerequisite ME 203. In years when ME294/294L are offered as an integrated course, this course may be used for the depth.

**Prerequisite Dynamic Systems (ME 161/261) and MATLAB programming.

Biomechanical Engineering

Sample Sequence of Courses

Starting with Math 40 Series, Chemistry, Biology, & Design track

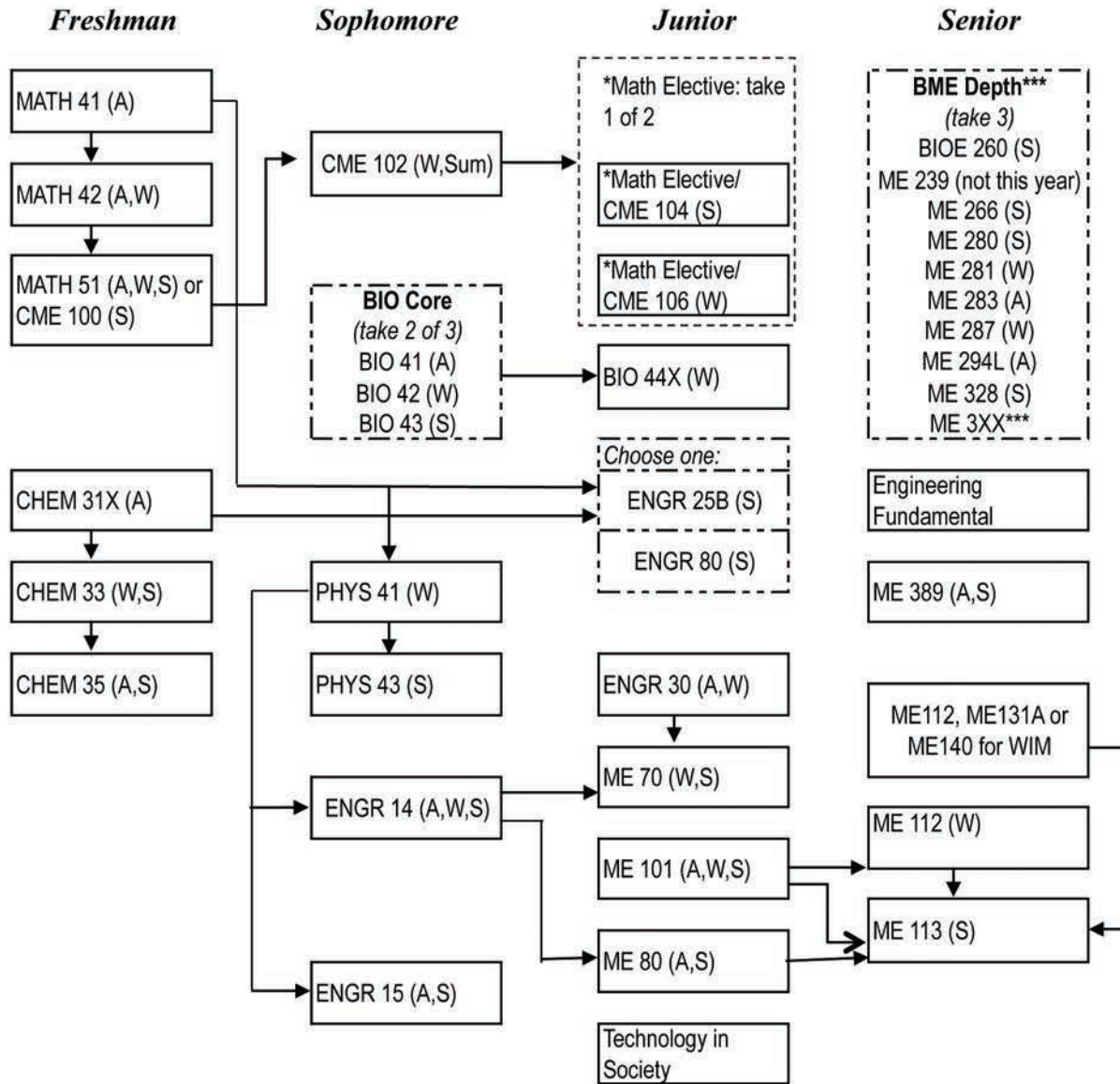

* Arrows represent direct prerequisites

* Dashed-line boxes enclose alternates. These may indicate alternate years in which to take a given course, and/or alternate courses that may be taken at a given time.

** BME Depth courses may vary year-to-year. BME depth courses may have expected prerequisites that should be discussed with the academic advisor or course instructor.

***Graduate-level biomechanics courses may be used towards the BME depth with permission of instructor and approval from the major advisor.

Biomechanical Engineering

Sample Sequence of Courses

Starting with Math 50 Series, Physics, HumBio, & Fluids Track

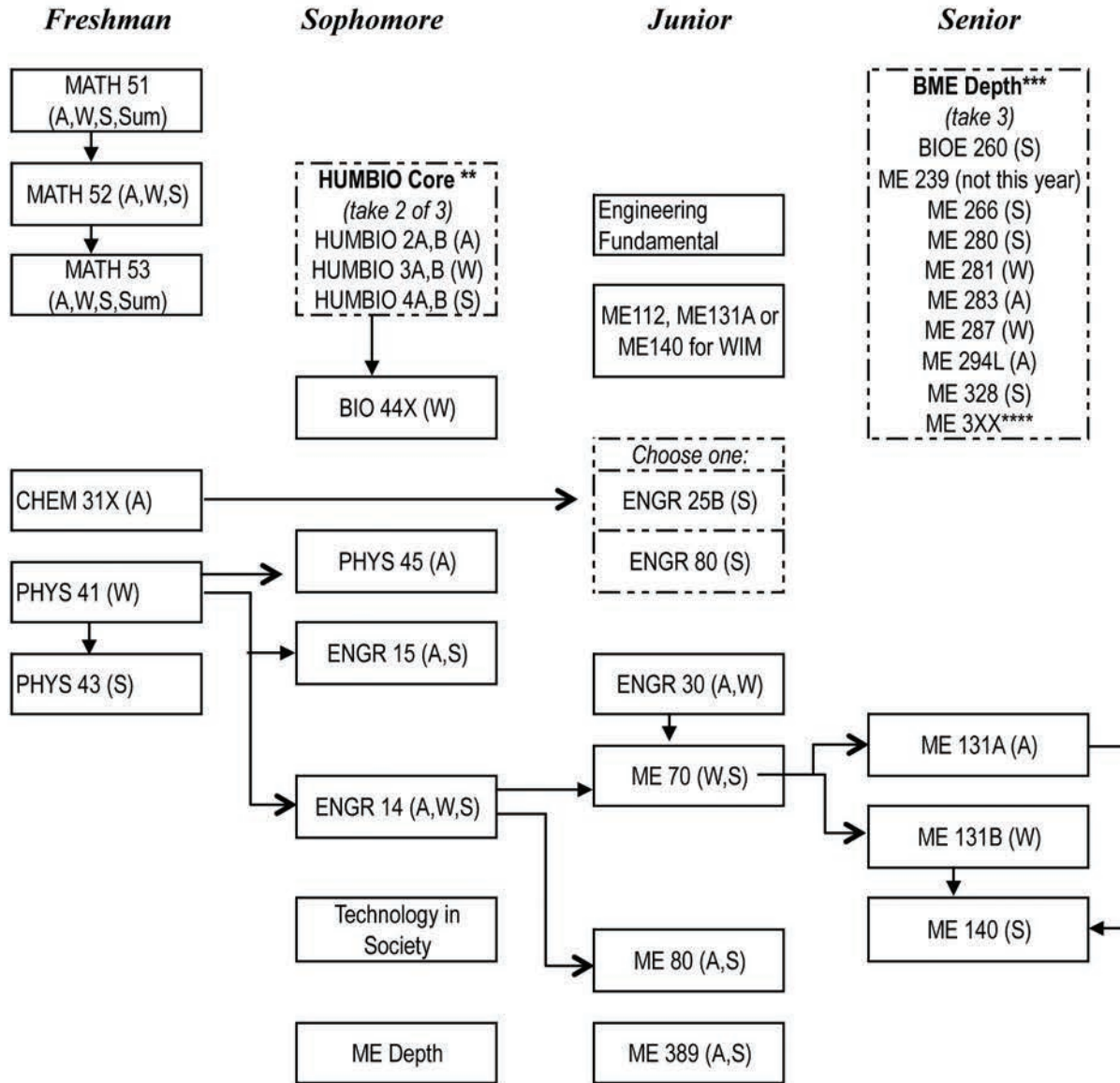

* Arrows represent direct prerequisites

* Dashed-line boxes enclose alternates. These may indicate alternate years in which to take a given course, and/or alternate courses that may be taken at a given time.

** According to the Human Biology Department, students taking the A series of the HumBio core must take the B series at the same time.

*** BME Depth courses may vary year-to-year. BME depth courses may have expected prerequisites that should be discussed with the academic advisor or course instructor.

****Graduate-level biomechanics courses may be used towards the BME depth with permission of instructor and approval from the major advisor.

Biomechanical Engineering

4 Year Plan: Starting with MATH 40 series; with Chemistry

	<i>Fall</i>			<i>Winter</i>				<i>Spring</i>					
	Class	Math/ Sci.	Engr.	Other	Class	Math/ Sci.	Engr.	Other	Class	Math/ Sci.	Engr.	Other	
<i>Freshman</i>	WAYS			4	MATH 42	5			WAYS/THINK			4	
	MATH 41	5			IntroSem			4	CHEM 33	5			
	CHEM 31A*	5			CHEM 31B*	5			Elective			5	
									WAYS			3	
	<i>Subtotals</i>	10	0		4	<i>Subtotals</i>	10	0		4	<i>Subtotals</i>	5	0
Total				14	Total				14	Total			17
<i>Sophomore</i>	BIO 41	5			BIO 42	5			BIO 43	5			
	WAYS			4	PHYSICS 41	4			ME101			3	
	CHEM 35		4		CME 102	5			ENGR 14			4	
	CME 100	5							TiS Course			3	
	<i>Subtotals</i>	10	4		4	<i>Subtotals</i>	14	0		0	<i>Subtotals</i>	5	10
Total				18	Total				14	Total			15
<i>Junior</i>	BME Depth		4		ENGR 30		3		ENGR 25B			3	
	ME 203		4		ME 70		4		Language**			5	
	ME 103D		1		BIO 44x	5			WAYS			3	
	Language**			5	Language**			5	WAYS			4	
	WAYS			4									
<i>Subtotals</i>	0	9		9	<i>Subtotals</i>	5	7		5	<i>Subtotals</i>	0	3	12
Total				18	Total				17	Total			15
<i>Senior</i>	ME 80		4		ME Depth		4		ME Depth			3	
	BME Depth		3		BME Depth		3		WAYS			5	
	ME 389		1		WAYS			4	Elective			4	
	BME Depth		4		Elective			4	WAYS			4	
	ME Depth		3										
<i>Subtotals</i>	0	8		0	<i>Subtotals</i>	0	7		8	<i>Subtotals</i>	0	3	13
Total				16	Total				15	Total			16

Total Math & Science Units: 59

Total Engineering Units: 57

Total Other Units: 71

Total Units: 187

Notes:

ME112 or ME131A or ME140 will fulfill the WIM requirement. Alternatively, ENGR 199W with directed research units, fulfills the "Writing in the Major" (WIM) requirement.

* CHEM 31A/B may be replaced with 31X (accel'd) or ENGR 31. CHEM 31A is not considered a stand-alone course.

** Students who place out of the language requirement should replace language units with technical electives.

➔ The School of ENGR encourages a quarter abroad. For detail on in-person or online ENGR course options see the Overseas Programs & Engineers page on the UGHB website or Chap 8 of the UGHB.

Biomechanical Engineering

4 Year Plan: Starting with MATH 40 series; with Physics

	<i>Fall</i>			<i>Winter</i>				<i>Spring</i>				
	Math/ Sci.	Engr.	Other	Class	Math/ Sci.	Engr.	Other	Class	Math/ Sci.	Engr.	Other	
<i>Freshman</i>	WAYS			4	MATH 42	5		IntroSem			4	
	CHEM 31A*	5			THINK/WAYS		4	CHEM 33	5			
	MATH 41	5			CHEM 31B*	5		MATH 51	5			
					WAYS		4					
	<i>Subtotals</i>	10	0	4	<i>Subtotals</i>	10	0	8	<i>Subtotals</i>	10	0	4
	Total			14	Total			18	Total			14
<i>Sophomore</i>	BIO 41	5			BIO 42	5		PHYS 43	4			
	PHYS 45	4			PHYSICS 41	4		ENGR 14		4		
	MATH 52	5			MATH 53	5		TiS Course		3		
	WAYS			4	Engr. Fund.		3	ME Depth		3		
	<i>Subtotals</i>	14	0	4	<i>Subtotals</i>	14	3	0	<i>Subtotals</i>	4	10	0
	Total			18	Total			17	Total			14
<i>Junior</i>	ENGR 15		4		ENGR 30		3	ENGR 25B		3		
	ME Depth		4		ME 70		4	Language**			5	
	Language**			5	BIO 44x	5		WAYS			5	
	WAYS			4	Language**		5	ME Depth		3		
	<i>Subtotals</i>	0	8	9	<i>Subtotals</i>	5	7	5	<i>Subtotals</i>	0	6	10
	Total			17	Total			17	Total			16
<i>Senior</i>	ME 80		4		ME Depth		4	Elective			4	
	BME Depth		3		BME Depth		3	WAYS			5	
	ME 389		1		WAYS		4	Elective			4	
	BME Depth		4		Elective		4					
Sci Elective	4											
	<i>Subtotals</i>	4	8	0	<i>Subtotals</i>	0	7	8	<i>Subtotals</i>	0	0	13
	Total			12	Total			15	Total			13

Total Math & Science Units: 71
 Total Engineering Units: 49
 Total Other Units: 65
Total Units: 185

Notes:

ME112 or ME131A or ME140 will fulfill the WIM requirement. Alternatively, ENGR 199W with directed research units, fulfills the "Writing in the Major" (WIM) requirement.

* CHEM 31A/B may be replaced with 31X (accelerated) or ENGR 31. CHEM 31A is not considered a stand-alone course.

** Students who place out of the language requirement should replace language units with technical electives.

➔ The School of ENGR encourages a quarter abroad. For detail on in-person or online ENGR course options see the Overseas Programs & Engineers page on the UGHB website or Chap 8 of the UGHB.

Biomechanical Engineering

4 Year Plan: Starting with CME 100, 102, 104 and BIO Core

	<i>Fall</i>				<i>Winter</i>				<i>Spring</i>			
	Class	Math/ Sci.	Engr.	Other	Class	Math/ Sci.	Engr.	Other	Class	Math/ Sci.	Engr.	Other
<i>Freshman</i>	WAYS			4	CME 102		5		IntroSem			4
	CHEM 31A*	5			THINKWAYS			4	CHEM 33	5		
	CME 100		5		CHEM 31B*	5			CME 104		5	
	<i>Subtotals</i>	5	5	4	<i>Subtotals</i>	5	5	4	<i>Subtotals</i>	5	5	4
	Total			14	Total			14	Total			14
<i>Sophomore</i>	BIO 41	5			BIO 42	5			PHYS 43	4		
	PHYS 45	4			PHYSICS 41	4			ENGR 14		4	
	WAYS			4	Engr. Fund.		3		Sci Elective	4		
					BIO 44x	5			ME Depth		3	
	<i>Subtotals</i>	9	0	4	<i>Subtotals</i>	14	3	0	<i>Subtotals</i>	8	7	0
	Total			13	Total			17	Total			15
<i>Junior</i>	ENGR 15		4		ENGR 30		3		ENGR 25B		3	
	ME Depth		4		ME 70		4		Language**			5
	Language**			5	Language**			5	WAYS			5
	WAYS			4	ME 203**		4		ME Depth		3	
	<i>Subtotals</i>	0	8	9	<i>Subtotals</i>	0	11	5	<i>Subtotals</i>	0	6	10
	Total			17	Total			16	Total			16
<i>Senior</i>	ME 80		4		ME Depth		4		Elective			4
	BME Depth		3		BME Depth		3		WAYS			5
	ME 389		1		WAYS			4	Elective			4
	TIS Course			4	Elective			4	WAYS			4
	BME Depth		4									
	<i>Subtotals</i>	0	12	4	<i>Subtotals</i>	0	7	8	<i>Subtotals</i>	0	0	17
	Total			16	Total			15	Total			17

Total Math & Science Units: 46
 Total Engineering Units: 69
 Total Other Units: 69
Total Units: 184

Notes:

ME112 or ME131A or ME140 will fulfill the WIM requirement. Alternatively, ENGR 199W with directed research units, fulfills the "Writing in the Major" (WIM) requirement.

* CHEM 31A/B may be replaced with 31X (accelerated) or ENGR 31. CHEM 31A is not considered a stand-alone course.

** Students who place out of the language requirement should replace language units with technical electives.

➔ The School of ENGR encourages a quarter abroad. For detail on in-person or online ENGR course options see the Overseas Programs & Engineers page on the UGHB website or Chap 8 of the UGHB.

Biomechanical Engineering

4 Year Plan: Starting with MATH 50 Series and Human Biology Core

	<i>Fall</i>			<i>Winter</i>				<i>Spring</i>				
	Class	Math/ Sci.	Engr.	Other	Class	Math/ Sci.	Engr.	Other	Class	Math/ Sci.	Engr.	Other
<i>Freshman</i>	WAYS			4	MATH 52	5			THINK/WAYS			4
	CHEM 31A*	5			IntroSem			4	CHEM 33	5		
	MATH 51	4			CHEM 31B*	5			MATH 53	5		
	<i>Subtotals</i>	<i>9</i>	<i>0</i>	<i>4</i>	<i>Subtotals</i>	<i>10</i>	<i>0</i>	<i>4</i>	<i>Subtotals</i>	<i>10</i>	<i>0</i>	<i>4</i>
	Total			13	Total			14	Total			14
<i>Sophomore</i>	HUMBIO 2A	5			HUMBIO 3A	5			PHYSICS 43	4		
	HUMBIO2B	5			HUMBIO 3B	5			ENGR 14		4	
	WAYS			4	PHYSICS 41	4			ENGR Fund.		5	
									ME Depth		3	
<i>Subtotals</i>	<i>10</i>	<i>0</i>	<i>4</i>	<i>Subtotals</i>	<i>14</i>	<i>0</i>	<i>0</i>	<i>Subtotals</i>	<i>4</i>	<i>12</i>	<i>0</i>	
	Total			14	Total			14	Total			16
<i>Junior</i>	ENGR 15		4		ENGR 30		3		ENGR 25B		3	
	ME Depth		4		ME 70		4		Language**			5
	Language**			5	Language**			5	WAYS			5
	WAYS			4	BIO 44X	4			ME Depth		3	
<i>Subtotals</i>	<i>0</i>	<i>8</i>	<i>9</i>	<i>Subtotals</i>	<i>4</i>	<i>7</i>	<i>5</i>	<i>Subtotals</i>	<i>0</i>	<i>6</i>	<i>10</i>	
	Total			17	Total			16	Total			16
<i>Senior</i>	ME 80		4		ME Depth		4		Elective			4
	BME Depth		3		BME Depth		3		WAYS			5
	ME 389		1		WAYS			4	Elective			4
	TIS Course			4	Elective			4	Sci Elective	4		
BME Depth		3										
<i>Subtotals</i>	<i>0</i>	<i>11</i>	<i>4</i>	<i>Subtotals</i>	<i>0</i>	<i>7</i>	<i>8</i>	<i>Subtotals</i>	<i>4</i>	<i>0</i>	<i>13</i>	
	Total			15	Total			15	Total			17

Total Math & Science Units: 65

Total Engineering Units: 51

Total Other Units: 65

Total Units: 181

Notes:

ME112 or ME131A or ME140 will fulfill the WIM requirement. Alternatively, ENGR 199W with directed research units, fulfills the "Writing in the Major" (WIM) requirement.

* CHEM 31A/B may be replaced with 31X (accelerated) or ENGR 31. CHEM 31A is not considered a stand-alone course.

** Students who place out of the language requirement should replace language units with technical electives.

➔ The School of ENGR encourages a quarter abroad. For detail on in-person or online ENGR course options see the Overseas Programs & Engineers page on the UGHB website or Chap 8 of the UGHB.

INSTRUCTIONS FOR DECLARING MAJOR IN ENGINEERING: BIOMECHANICAL ENGINEERING (ENGR-BS)

1. Print a copy of your transcript from Axess.
2. Download the BSE:BME program sheet from the School of Engineering web site (<http://ughb.stanford.edu>). Please make sure to include courses you plan to take as well as those you have already taken. Complete the sheet and attach a ½ page Statement of Purpose.
3. Set up a short appointment with the BME undergraduate coordinator: bme-ugradsc@lists.stanford.edu to discuss proposed courses, advisors, etc.
4. Pick up a BME major declaration form from the Mechanical Engineering Student Services Office (Building 530, room 125)
5. Identify an undergraduate program advisor from the list on the back of the major declaration form. If you prefer, the Student Services Office will assign one to you.
6. Discuss the program with your BME advisor and have him/her approve and sign your program sheet and declaration form.
7. Return completed documents (including any transfer credit forms) to the Student Services Office.
8. Login to Axess and formally declare your major. **NOTE: Select “Engineering” as your major (NOT Mechanical Engineering), with a subplan in “Biomechanical Engineering”.**
9. Email Kelly Guerriero (kellybg@stanford.edu) and ask her to approve your declaration.

Note: The online version of your major (link from the Home or Major Programs page of the UGHB website) is considered the definitive version of 2014-15 requirements; corrections or updates may have been made after the printed and pdf versions were published in August 2014.

★ You must use a program sheet from a year you have been enrolled at Stanford.

Stanford University ♦ School of Engineering
Biomechanical Engineering
2014–2015 Program Sheet

Final version of completed and signed program due to the department no later than one month prior to the last quarter of senior year.

Follow all requirements as stated for the year of the program sheet used.

Name: _____ SU ID #: _____
 Phone: _____ Email: _____
 Today's Date: _____ Month/Yr B.S. expected: _____

Mathematics and Science Requirements

Dept	Course	Title	Transfer/AP Approval by SoE			Unit	Grade
			✓ if Transfer	SoE Initials	Date		
<i>Mathematics (21 units minimum)</i>							
CME	100	or MATH 51 (req'd)				5	
CME	102	or MATH 53 (req'd)				5	
STATS		req'd; see UGHB Fig 3-1; STATS 60 not allowed				4 to 5	

Mathematics (21 units minimum)

Science (22 units minimum, see note 1)

BIO	44X	Biology Labs (see Note 2)				5	
BIO/HumBio		BIO Core/ HumBio A/B Core				5	
BIO/HumBio		BIO Core/ HumBio A/B Core				5	
CHEM	31X	Chemical Principals (see note 1)				5	
PHYSICS	41	Mechanics				4	

Science (22 units minimum)

Mathematics and Science (43 units minimum)

Technology in Society Requirement (1 course req'd; see UGHB, Chap 3, Fig. 3-3 for SoE approved list)

--	--	--	--	--	--	--	--

Engineering Fundamentals (3 courses required - see UGHB Chap 3, Fig. 3-4 for SoE approved list)

Dept	Course	Title	Transfer/AP Approval			Units	Grade
			✓ if Transfer	Initials	Date		
ENGR	14	Introduction to Solid Mechanics				4	
ENGR	25B	Biotechnology (or ENGR 80)				3	
		Fundamental Elective (alt. ENGR 25 courses not allowed if 25B taken)					

NOTES

- * All courses taken for the major must be taken for a letter grade if that option is offered by the instructor.
 - * This form is available as an Excel file at <http://ughb.stanford.edu/>; you must use a program sheet from a year you are enrolled at Stanford. The printed form must be signed by the advisor and, if required, by the departmental representative. Changes must be initialed in ink.
 - * Read all emails from your major department; this is the SoE's only method of conveying key information to you.
 - * Transfer and AP credits in Math, Science, Fundamentals, & TIS must be approved by the SoE Dean's office. Transfer credits in Engineering Depth must be approved by the Advisor. Transfer credit information and petitions are available at <http://ughb.stanford.edu/transfer.html>.
 - * All courses listed on this form must only be included under one category. Delete courses not taken.
- (1) Must include both Chemistry and Physics with a depth (3 quarters) in at least one, 2 quarters of HumBio A/B core or Bio core, and CHEM 31X (or CHEM 31A+B or ENGR 31). A depth in chemistry can be fulfilled with CHEM 31A/B & CHEM 33 or CHEM 31X & CHEM 33. Only 2 qtrs of BIO are req'd but students taking HumBio must take both A & B side.
 - (2) WIM may be satisfied by a) taking ME112, ME131A or ME140 or b) performing full-time BME research over the summer and enrolling in ENGR 199W the following Autumn (required forms available in the ME student services office). BIO44X taken after 2010-2011 no longer satisfies the WIM requirement.

Engineering Depth: ME Core (Be advised, no course may be listed twice on this sheet; no double-counting.)							
Dept	Course	Title	Transfer/Deviation Approval by Advisor			Units	Grade
			Advisor Initials	Date			
ENGR	15	Dynamics				4	
ENGR	30	Engineering Thermodynamics				3	
ME	70	Introductory Fluids Engineering				4	
ME	80	Mechanics of Materials				4	
ME	389	Biomechanical Research Symposium (see Note 3)				1	
						ME Core Units	

One Writing in the Major course required. For WIM options, see Note 2 on page 1

Options to complete ME depth sequence (select 3 courses, min. 9 units; see note 4)

						ME Depth Units (9 units minimum)	

Options to complete BME depth sequence (select 3 courses, minimum 9 units; see note 5)

						BME Depth Units (9 units minimum)	
						Engineering Depth Unit Totals (33 units minimum)	

Additional Math, Science or Engineering Courses (as needed to bring unit total to 99)

						BME Elective Units (as needed)	

Program Totals

Mathematics and Science (43 units minimum)	
Engineering & Fundamentals Depth (42 units minimum)	
TIS Course + Depth Electives	
Total Program Units (99 units minimum)	

Program Approvals (see note 6)

Advisor

Printed Name: _____

Date: _____

Signature: _____

Departmental

Printed Name: _____

Date: _____

Signature: _____

School of Engineering (No action required-office use only)

Printed Name: _____

Date: _____

Signature: _____

NOTES (continued from page 1)

- * Minimum combined grade point average for all courses in Engineering Topics (Engr Funds & Depth) is 2.0
- (3) If ME 389 is not offered, other options include BIOE 393 or ME 571, or by petition.
- (4) Choose three courses from ENGR 105, ME 101, 112, 113, 131A, 131B, 140, 161, 203, 210, 220. (Recommended that BME students take ME 203 winter or spring quarter).
- (5) Choose 3 courses from BIOE260, ME 239, 266, 280, 281, 283, 287, 294L, 328, or ME 3XX (graduate-level biomechanics courses may be used toward the BMC depth with permission of instructor and approval from the major advisor. Students should be aware of prerequisites for BME depth courses. Some courses may not be available in a given year).
- (6) To Declare: Bring completed Program Sheet and 1/2 page Statement of Purpose to the Student Services Office, Bldg. 530, Room 125. This form must be completed and approved by the first quarter of the junior year; a final, updated, and re-signed form must be submitted by the second quarter of the senior year.

BIOMEDICAL COMPUTATION

Computational techniques are now being used to ask and answer fundamental questions in biology and medicine in ways never before possible. The Biomedical Computation (BMC) major allows students to focus on this exciting interdisciplinary field – the use of advanced computational techniques in biology and medicine.

BMC is an IDP, or interdisciplinary program, with its home in the School of Engineering. Students who major in BMC will gain a rigorous foundation in the many component fields that go into biomedical computation, including computer science, math and statistics, biology, and chemistry. Each student then has the opportunity to pursue one of four tracks most suited to his or her interests.

Our graduates have gone on to pursue a wide range of paths after graduation. Many of our students have chosen to continue their studies and pursue advanced degrees in various fields, including bioinformatics, bioengineering, or any of the pure biological or computational sciences. We have also had a number of students enroll in medical school or MD/PhD programs. BMC graduates have also ended up in fields a bit farther away from biomedical computation, such as law school, management consulting, and others. BMC gives students a solid foundation in a number of different fields, and students have the ability to pursue a variety of career paths in any of the fields that make up the major.

COMPONENTS OF BMC:

BMC Core: Math, Science, Engineering Fundamentals, and TIS

All BMC students take courses to get a solid foundation in the component disciplines of biomedical computation. Most of these courses are typically taken during freshman and sophomore year. These courses include:

Math: MATH 41, 42, STATS 116 (or equivalent), and one additional math course specific to your track.

Chemistry: CHEM31A+B *or* 31X *or* ENGR 31; CHEM 33

Biology: BIO Core or Human Biology Core (each is a 3-quarter sequence, ideally taken in sophomore year)

Physics: PHYSICS 41

Computer Science: CS 107; CS106B or X; CS103; CS 161

Engineering Fundamentals: CS 106 (see above) plus one additional elective (may not be CS 106A; see Chapter 3, Figure 3-4 for list of other SoE approved courses)

Technology in Society (TIS): One course required; see list of SoE approved courses in Chapter 3, Figure 3-3. HUMBIO 174, Foundations of Bioethics (3 units, Wtr, prerequisite of HUMBIO core), is an option to fulfill this requirement only for BMC majors.

Please see the program sheets for the exact course list.

Tracks

For the upper division courses in the major, a student must choose between one of the four tracks of BMC. The four tracks are

Informatics

Simulation

Cellular/Molecular

Organs/Organ Systems

Two of the tracks, Informatics and Simulation, place a bit more emphasis on the computational aspects of the discipline, while the other two, Cellular/Molecular and Organs/Organ Systems, provide more depth in biology.

Each of the tracks consists of a core of about three to five courses. These are courses that provide students the core knowledge related to their in-depth area of study. The tracks also have elective requirements, to ensure students gain breadth in upper division courses as well. The entire track portion of BMC is composed of nine to ten courses in total. Lists of electives can be found on the BMC website bmc.stanford.edu.

BMC Depth: Research, Writing in the Major, and Capstone Class

Research: Every BMC student must complete 6 units of directed research under a faculty member. This requirement of research is fairly unique to BMC among majors at Stanford. It allows our students to work on cutting-edge projects as a part of their undergraduate curriculum. This research typically occurs during the junior or senior year, and may be undertaken with faculty members from any School at Stanford. The main requirement is that the student be doing actual, hands-on biomedical computation as a part of the research project. The student must get approval from the BMC Program Directors before undertaking his or her research project.

WIM: The Writing in the Major requirement gives students an opportunity to learn to effectively communicate ideas in their fields of study. In BMC, there are two ways to satisfy this requirement:

7. Students may fulfill the WIM requirement by writing a ~15 page technical report concurrently with performing the research for the research requirement. This report is in the form of a technical publication about the students work, and is completed under supervision of your research mentor and the School of Engineering writing tutors. For this option, student can either 1) Enroll in least 3 of the 6 research units as CS191W, or 2) enroll in 5 units of research and 1 unit of E199W.
8. Students wishing to satisfy their WIM requirement independently of their research work may enroll in CS272.

Capstone Class: The BMC Capstone class gives students the chance to take a rigorous course that thoroughly integrates various aspects of biology and computation. This course is typically taken during junior or senior year. Currently, this requirement is satisfied by one of the following courses: CS270, CS273A, CS274, CS275, CS278, or CS279

ADVISING IN BMC

There are two types of advisors for the major: an academic advisor and a research advisor. The academic advisor is the person who oversees your path through BMC. It is necessary to have found an academic advisor in order to declare the major. Because BMC is in the School of

Engineering, the student's academic advisor must have an appointment in the School of Engineering. The one major commitment that this advisor makes in BMC that is different from other majors is that, in the case that the BMC student has trouble finding a research mentor, the academic advisor agrees that the student can work in his or her lab to fulfill the BMC research requirement.

The other advisor is the research mentor. Because there is interesting biomedical computation work being done throughout Stanford, not just in the School of Engineering, we place no restrictions as to where within Stanford the faculty mentor conducts his or her research. It is not necessary to have a research advisor at the time of declaring; many of our students do not. It is acceptable for the same faculty member to serve as both the academic and research advisor for a BMC student.

For additional information about the major, and for step-by-step instructions on how to declare, please visit the BMC website at <http://bmc.stanford.edu>. If you have further questions, please contact the student advisor for the major, Dr. Amit Kaushal, at akaushal@stanford.edu.

PROGRAM OPTIONS

If I do BMC can I also...

Be Premed?

Yes. This requires taking about six additional chemistry, physics, and biology lab courses. While we can offer some advice here, it is important to talk to a premed advisor to cover which additional courses you need to take.

Study abroad?

Absolutely! Though the major requirements are many, it is quite possible to go abroad. The earlier you start planning, the easier this will be.

Do an Honor thesis?

Yes. The full requirements for honors are described in Chapter 6 and on the BMC website. Please contact BMC Advisor Dr. Amit Kaushal (akaushal@stanford.edu) if you are interested in this option.

Add an additional major or minor in something else?

Yes. While the major is demanding, some students have managed to squeeze in other areas of study as well. Some students have asked about double-majoring or minoring in Computer Science or Biology. It does not make much sense to do so, since the BMC major has a large number of courses from these departments already. BMC majors can tailor their curriculum so that they are quite well trained in either of these disciplines.

Coterm?

Absolutely. Stanford offers students the opportunity to study an additional year or so and obtain a coterminal Master's degree. Many of our students have gone on to coterm in various departments at Stanford. Please contact the department in which you wish to coterm in your junior year – requirements vary from department to department, and this will leave enough time to plan for the application process and the courses you might have to take before enrolling.

MAJOR REQUIREMENTS FOR ALL BMC TRACKS:

See chart on next page for course requirements for all four tracks. For the most up-to-date information on BMC courses, go to <http://bmc.stanford.edu>

Note: The online version of your major (link from the Home or Major Programs page of the UGHB website) is considered the definitive version of 2014-15 requirements; corrections or updates may have been made after the printed and pdf versions were published in August 2014.

★ You must use a program sheet from a year you have been enrolled at Stanford.

	Informatics	Simulation	Cellular/Molecular	Organs/Organisms
SoE: Math Requirement	Math 41 and 42: Calculus			
	CS109 or CME 106 or STATS116 or MS&E220 or EE178: Probability			
	CS103: Mathematical Foundations of Computing			
	CS161: Data Structures and Algorithms			
SoE: Science Requirement	STAT141 or STAT 203 or STAT 205 or STAT 215 or STAT 225: Advanced Statistics/Biostatistics	CME100 or MATH 51: Advanced Calculus I	CME100, MATH 51, or STAT 141: Advanced Calculus or Biostatistics	CME100, MATH 51, or STAT 141: Advanced Calculus or Biostatistics
	Physics 41: Mechanics			
	CHEM 31A and B, or CHEM 31X or ENGR 31: Chemical Principles (regular or accelerated)			
	CHEM 33: Structure and Reactivity			
	BIO 41 or HUMBIO 2A: Biology or Human Biology Core I	BIO 42 or HUMBIO 3A: Biology or Human Biology Core II	BIO 43 or HUMBIO 4A: Biology or Human Biology Core III	
SoE: TIS	Technology in Society: 1 course; see UGHB, Fig. 3-3 for approved list			
	CS106B or CS106X: Programming Abstractions			
SoE: Engineering Fundamentals	Any add'l ENGR fund except CS 106	E30: Thermodynamics	Any add'l ENGR fund except CS 106	Any add'l ENGR fund except CS 106
	CS107: Programming Paradigms			
BMC Depth: Additional BMC Core requirements	Capstone Class: One of CS270, CS273A, CS274, CS275, CS278, or CS279			
	Independent Research: 6 units, any department			
	CS191W, E199W, or CS272: Writing in the Major (see note 1)			
BMC Depth: Track Core and Elective Requirements	CS145: Databases or CS147: HCI	CME102 or MATH 53: Advanced Calculus II	BIO129A: Cell Bio I	BIO112: Physiology
	CS121 or 221, or CS228 or CS229 or CS 223B (AI/Machine Learning)	ENGR 80: Introduction to Bioengineering	BIO129B: Cell Bio II	BIO188 or BIOE/RAD 220: Biochemistry or Intro to Imaging
	One additional course from the Informatics core (CS145, 147, 121, 221, 228, 229 or 223B)	BIOE 101: Systems Biology	BIO188 or CHEM135 or CHEM171: Biochemistry or Physical Chemistry	Organs Elective
	Informatics Elective	BIOE 103: Systems Phys/Design	BIO203 or 118: Genetics	Organs Elective
	Informatics Elective	Simulation Elective	Informatics Elective	Informatics Elective
	Informatics Elective	Simulation Elective	Simulation Elective	Simulation Elective
	Cell/Mol Elective	Cell/Mol Elective	Informatics or Simulation Elective	Informatics or Simulation Elective
	Cell/Mol Elective	Organs Elective	Informatics or Simulation Elective	Informatics or Simulation Elective
	Organs Elective	Sim, Organs, or Cell/Mol Elective	Inf, Sim, or Cell/Mol Elec.	Inf, Sim, or Organs Elec.
	Organs Elective	Sim, Organs, or Cell/Mol Elective		

(1) Students may fulfill Writing in the Major and research requirements with E199W or CS191W, or may take CS272 to fulfill WIM only. See program sheet for details.

Biomedical Computation

Typical Sequence of Courses

Freshman	Sophomore	Junior	Senior
CS 106B or CS 106X	CS 107	Track-specific math course	
MATH 41 (A)	CS103, CS161	Core and elective courses for specific track** (~9-10 courses)	
MATH 42 (A,W)	BIO 41 or HUMBIO 2A (A)		
PHYSICS 41 (W)	BIO 42 or HUMBIO 3A (W)		
	BIO 43 or HUMBIO 4A (S)		
CHEM 31A+B (A,W) or CHEM 31X (A) or ENGR 31(A)			
CHEM 33 (W,S)		Capstone Course	
CS109 or CME 106 or equivalent (see program sheets)		Research (6 units) + WIM	
Engineering Fundamentals - 1 elective (in addition to CS 106, above)			
TIS Requirement - 1 course			

*The CS, MATH, STATS, CHEM, and BIO courses listed under freshman and sophomore year tend to be prerequisites for the upper-division core and elective courses in the major. Thus, it is worth taking these courses during the first two years of study if possible.

** For complete details about courses for each of the BMC tracks, visit bmc.stanford.edu.

Biomedical Computation

Informatics

	<i>Fall</i>				<i>Winter</i>				<i>Spring</i>			
	Class	Math/ Sci.	Engr.	Other	Class	Math/ Sci.	Engr.	Other	Class	Math/ Sci.	Engr.	Other
<i>Freshman</i>	MATH 41	5	-	-	MATH 42	5	-	-	CS106A	-	5	-
	CHEM 31A	5	-	-	CHEM31B	5	-	-	CHEM33	5	-	-
	<i>Subtotals</i>	<i>10</i>	<i>0</i>	<i>0</i>	<i>Subtotals</i>	<i>10</i>	<i>0</i>	<i>0</i>	<i>Subtotals</i>	<i>5</i>	<i>5</i>	<i>0</i>
	Total			10	Total			10	Total			10
<i>Sophomore</i>	BIO 41	5	-	-	BIO 42	5	-	-	BIO 43	5	-	-
	CS106B/X	-	5	-	CS109	-	5	-	CS107	-	5	-
	CS103	-	5	-	PHYSICS41	4	-	-	ENGR80	-	4	-
	<i>Subtotals</i>	<i>5</i>	<i>10</i>	<i>0</i>	<i>Subtotals</i>	<i>9</i>	<i>5</i>	<i>0</i>	<i>Subtotals</i>	<i>5</i>	<i>9</i>	<i>0</i>
Total			15	Total			14	Total			14	
<i>Junior</i>	CS161	-	5	-	CS221	-	4	-	Elec - Inf	-	3	-
	CS145	-	4	-	STATS141	5	-	-	Elec - Cell	-	3	-
	Elec - Organs	-	3	-	Elec - Cell	-	3	-				
	<i>Subtotals</i>	<i>0</i>	<i>12</i>	<i>0</i>	<i>Subtotals</i>	<i>5</i>	<i>7</i>	<i>0</i>	<i>Subtotals</i>	<i>0</i>	<i>6</i>	<i>0</i>
Total			12	Total			12	Total			6	
<i>Senior</i>	CS191	-	3	-	CS191W	-	3	-	TechInSociety	-	4	-
	CS274	-	4	-	Elec - Organs	-	3	-	Elec - Inf	-	3	-
	CS229	-	4	-	Elec - Inf	-	3	-				
	<i>Subtotals</i>	<i>0</i>	<i>11</i>	<i>0</i>	<i>Subtotals</i>	<i>0</i>	<i>9</i>	<i>0</i>	<i>Subtotals</i>	<i>0</i>	<i>7</i>	<i>0</i>
Total			11	Total			9	Total			7	

Total Math & Science Units: 44

Total Engineering Units: 81

Total Other Units: 0

Total Units: 125

→ The School of ENGR encourages a quarter abroad. For detail on in-person or online ENGR course options see the Overseas Programs & Engineers page on the UGHB website or Chap 8 of the UGHB.

Biomedical Computation

Simulation

	<i>Fall</i>			<i>Winter</i>			<i>Spring</i>					
	Math/ Sci.	Engr.	Other	Class	Math/ Sci.	Engr.	Other	Class	Math/ Sci.	Engr.	Other	
<i>Freshman</i>	MATH 41	5	-	-	MATH 42	5	-	-	CS106A	-	5	-
	CHEM 31A	5	-	-	CHEM31B	5	-	-	CHEM33	5	-	-
	<i>Subtotals</i>	10	0	0	<i>Subtotals</i>	10	0	0	<i>Subtotals</i>	5	5	0
	Total	10			Total	10			Total	10		
<i>Sophomore</i>	BIO 41	5	-	-	BIO 42	5	-	-	BIO 43	5	-	-
	CS106B/X	-	5	-	CS109	-	5	-	CS107	-	5	-
	CS103	-	5	-	PHYSICS41	4	-	-	ENGR80	-	4	-
	<i>Subtotals</i>	5	10	0	<i>Subtotals</i>	9	5	0	<i>Subtotals</i>	5	9	0
Total	15			Total	14			Total	14			
<i>Junior</i>	CS161	-	5	-	CME102	-	5	-	BIOE103	-	4	-
	CME100	-	5	-	ENGR30	-	3	-	Elec - Sim	-	3	-
	BIOE101	-	4	-	Elec - Gen	-	4	-	Elec - Cell	-	3	-
	<i>Subtotals</i>	0	14	0	<i>Subtotals</i>	0	12	0	<i>Subtotals</i>	0	10	0
Total	14			Total	12			Total	10			
<i>Senior</i>	CS191	-	3	-	CS191W	-	3	-	TechInSociety	-	4	-
	CS274	-	4	-	Elec - Sim	-	3	-	Elec - Gen	-	3	-
	Elec - Organs	-	3	-								
	<i>Subtotals</i>	0	10	0	<i>Subtotals</i>	0	6	0	<i>Subtotals</i>	0	7	0
Total	10			Total	6			Total	7			

Total Math & Science Units: 44

Total Engineering Units: 88

Total Other Units: 0

Total Units: 132

→ The School of ENGR encourages a quarter abroad. For detail on in-person or online ENGR course options see the Overseas Programs & Engineers page on the UGHB website or Chap 8 of the UGHB.

Biomedical Computation

Cellular and Molecular

	<i>Fall</i>				<i>Winter</i>				<i>Spring</i>			
	Class	Math/ Sci.	Engr.	Other	Class	Math/ Sci.	Engr.	Other	Class	Math/ Sci.	Engr.	Other
<i>Freshman</i>	MATH 41	5	-	-	MATH 42	5	-	-	CS106A	-	5	-
	CHEM 31A	5	-	-	CHEM31B	5	-	-	CHEM33	5	-	-
	<i>Subtotals</i>				<i>Subtotals</i>				<i>Subtotals</i>			
	Total				Total				Total			
<i>Sophomore</i>	BIO 41	5	-	-	BIO 42	5	-	-	BIO 43	5	-	-
	CS106B/X	-	5	-	CS109	-	5	-	CS107	-	5	-
	CS103	-	5	-	PHYSICS41	4	-	-	ENGR80	-	4	-
	<i>Subtotals</i>				<i>Subtotals</i>				<i>Subtotals</i>			
Total				Total				Total				
<i>Junior</i>	CS161	-	5	-	BIO129A	4	-	-	BIO129B	4	-	-
	CME100	-	5	-	Elec - Infor	-	3	-	BIO118	5	-	-
	CHEM 135	3	-	-	Elec - Sim	-	3	-	Elec - Gen	-	3	-
	<i>Subtotals</i>				<i>Subtotals</i>				<i>Subtotals</i>			
Total				Total				Total				
<i>Senior</i>	CS191	-	3	-	CS191W	-	3	-	TechInSociety	-	4	-
	CS274	-	4	-	Elec - Sim	-	3	-				
	Elec - Infor	-	3	-								
	<i>Subtotals</i>				<i>Subtotals</i>				<i>Subtotals</i>			
Total				Total				Total				

Total Math & Science Units: 60

Total Engineering Units: 68

Total Other Units: 0

Total Units: 128

➔ The School of ENGR encourages a quarter abroad. For detail on in-person or online ENGR course options see the Overseas Programs & Engineers page on the UGHB website or Chap 8 of the UGHB.

Biomedical Computation

Organs and Organisms

	<i>Fall</i>			<i>Winter</i>			<i>Spring</i>											
	Math/ Sci.	Engr.	Other	Class	Math/ Sci.	Engr.	Other	Class	Math/ Sci.	Engr.	Other							
<i>Freshman</i>	MATH 41	5	-	-	MATH 42	5	-	-	CS106A	-	5	-						
	CHEM 31A	5	-	-	CHEM31B	5	-	-	CHEM33	5	-	-						
	<i>Subtotals</i>			10	0	0	<i>Subtotals</i>			10	0	0	<i>Subtotals</i>			5	5	0
	Total			10			Total			10			Total			10		
<i>Sophomore</i>	BIO 41	5	-	-	BIO 42	5	-	-	BIO 43	5	-	-						
	CS106B/X	-	5	-	CS109	-	5	-	CS107	-	5	-						
	CS103	-	5	-	PHYSICS41	4	-	-	ENGR80	-	4	-						
	<i>Subtotals</i>			5	10	0	<i>Subtotals</i>			9	5	0	<i>Subtotals</i>			5	9	0
Total			15			Total			14			Total			14			
<i>Junior</i>	CS161	-	5	-	BIO112	-	4	-	Elec - Organs	-	3	-						
	CME100	-	5	-	BIOE220	-	3	-	Elec - Sim	-	3	-						
	<i>Subtotals</i>			0	10	0	<i>Subtotals</i>			0	10	0	<i>Subtotals</i>			0	6	0
	Total			10			Total			10			Total			6		
<i>Senior</i>	CS191	-	3	-	CS191W	-	3	-	TechInSociety	-	4	-						
	CS274	-	4	-	Elec - Infor	-	3	-	Elec - Gen	-	3	-						
	Elec - Organs	-	3	-	Elec - Sim	-	3	-										
	<i>Subtotals</i>			0	10	0	<i>Subtotals</i>			0	9	0	<i>Subtotals</i>			0	7	0
Total			10			Total			9			Total			7			

Total Math & Science Units: 44

Total Engineering Units: 81

Total Other Units: 0

Total Units: 125

→ The School of ENGR encourages a quarter abroad. For detail on in-person or online ENGR course options see the Overseas Programs & Engineers page on the UGHB website or Chap 8 of the UGHB.

INSTRUCTIONS FOR DECLARING MAJOR IN ENGINEERING: BIOMEDICAL COMPUTATION (ENGR-BS)

1. Gather information about the major by talking to students and professors.
2. Design a 4-year plan based on the samples previous pages.
3. Print a copy of your transcript from Axess.
4. Select an advisor (choose from the list of faculty listed under “BMC Faculty Advisors” on the BMC website at <http://bmc.stanford.edu>).
5. Download the BSE:BMC program sheet from the School of Engineering web site (<http://ughb.stanford.edu>).
6. Meet with your advisor to review the 4-year plan
7. Based on your plan, fill out your program sheet
8. Meet with either Prof. Russ Altman or Dr. Amit Kaushal (akaushal@stanford.edu) to get approval; have them sign your program sheet.
9. Turn in your completed and signed Program Sheet, 4-Year Plan, and an unofficial Stanford transcript to Darlene Lazar in 135 Huang. She will review for completion. You must then declare your major in Axess:
 - a. Select “Engineering” as your Major
 - b. Select “BMC” as your subplan
 - c. Ask Darlene (dlazar@stanford.edu) to approve your major in PeopleSoft
10. When your major is approved, Darlene will notify you via email.

Note: The online version of your major (link from the Home or Major Programs page of the UGHB website) is considered the definitive version of 2014-15 requirements; corrections or updates may have been made after the printed and pdf versions were published in August 2014.

★ You must use a program sheet from a year you have been enrolled at Stanford.

Stanford University ♦ School of Engineering
Biomedical Computation - Informatics Track
2014–2015 Program Sheet

Final version of completed and signed program due to the department no later than one month prior to the last quarter of senior year.

Follow all requirements as stated for the year of the program sheet used.

Name: _____ SU ID #: _____
 Phone: _____ Email: _____
 Today's Date: _____ Month/Yr B.S. expected: _____

Mathematics and Science Requirements

Dept	Course	Title	Transfer/AP Approval by SoE			Unit	Grade
			✓ if Transfer	SoE Initials	Date		
Mathematics (21 units minimum)							
MATH	41	Calculus				5	
MATH	42	Calculus				5	
		Probability: CS109 or STATS116 or MS&E120 or 220 or EE178 or CME106					
CS	103	Mathematical Foundations of Computing				5	
CS	161	Data Structures and Algorithms				4	
STATS 141, 203, 205, 215 OR 225		Advanced Statistics or Biostatistics					
<i>Mathematics Unit Total (21 units minimum)</i>							

Science (17 units minimum)

PHYS	41	Mechanics				4	
CHEM 31A&B or X or ENGR 31		Chemical Principles (regular or accelerated)					
CHEM	33	Structure & Reactivity				5	
BIO41 or HUMBIO2A		Biology or Human Biology Core I				5	
BIO42 or HUMBIO3A		Biology or Human Biology Core II				5	
BIO43 or HUMBIO4A		Biology or Human Biology Core III				5	
<i>Science Unit Total (17 units minimum)</i>							
<i>Math + Science Total (41 units minimum)</i>							

Technology in Society Requirement (1 course required; see UGHB, Fig. 3-3 for approved list)

--	--	--	--	--	--	--	--

Engineering Fundamentals (2 courses required)

CS	106B or X	Programming Abstractions				5	
		Elective (see note 1; CS 106A not allowed)					
<i>Engineering Fundamentals Total</i>							

NOTES

- * **All courses taken for the major must be taken for a letter grade if that option is offered by the instructor.**
 - * This form is available as an Excel file at <http://ughb.stanford.edu/>; you must use a program sheet from a year you are enrolled at Stanford. The printed form must be signed by the advisor and, if required, by the departmental representative. Changes must be initialed by your advisor or dept in ink.
 - * Read all emails from your major department; this is the School's only effective method of communicating with you.
 - * Minimum Combined Grade Point Average for all courses in the major (combined) is 2.0.
 - * Transfer & AP credits in Math, Science, Funds., & TIS must be approved by the SoE Dean's office. Transfer credits in Engr Depth must be approved by the Advisor. Information & petitions at <http://ughb.stanford.edu/>
 - * All courses listed on this form must only be included under one category. Delete courses not taken.
- (1) One course required, 3 to 5 units. CS 106A not allowed; See Engr Fundamentals list in Chap 3 of UGHB for alternatives

BMC Informatics Depth (42 units minimum; see note 2)

Dept	Course	Title	Transfer/Deviation Approval by Advisor			Units	Grade
			✓ if Transfer	Advisor Initials	Date		
Additional BMC Core requirements							
CS	107	Programming Paradigms				5	
CS270, CS273A, CS274, CS275, CS278, or CS279		Capstone Class - select one					
(any department)		Independent Research (see note 3)				6	
CS191W, E199W, or CS272		WIM (if not already satisfied by Independent Research - see note 3)					

Track Core (3 courses required)

CS145 or CS147		Databases or Human-Computer Interaction				4	
CS121 or 221, or CS228, or CS229, or CS223B		Artificial Intelligence/Machine Learning					
(additional course from above)		One additional course from Informatics track core (see previous two lines)					

Track Depth (7 courses required)

Informatics Electives (3 courses required: see note 4)

Cellular/Molecular Electives (2 courses required: see note 4)

Organs/Organisms Electives (2 courses required: see note 4)

BMC Depth Total (Total of all units on this page) (42 units minimum)

Program Totals

Mathematics and Science (41 units minimum)	<input type="text"/>
BMC Depth Total (Total of all units on this page) (42 units minimum)	<input type="text"/>
Engineering (Fundamentals + Depth) Units (see note 2) (40 units minimum)	<input type="text"/>

Program Approvals

Advisor

Printed Name: _____ Date: _____
 Signature: _____

Departmental

Printed Name: _____ Date: _____
 Signature: _____

School of Engineering (No action required-office use only)

Printed Name: _____ Date: _____
 Signature: _____

NOTES (continued from page 1)

- (2) 40 units of engineering courses are required, to be met through the Engr Fundamentals and BMC Depth courses.
- (3) Students must complete 6 units of BMC research in any department, with project approval from BMC program coordinators. Research can satisfy WIM if student enrolls in CS191W or E199W. See bmc.stanford.edu for details.
- (4) The list of electives is continually updated to include all applicable courses. For the current list of electives, please visit <http://bmc.stanford.edu>. Electives may only be listed once on program sheet; no double-counting.

Stanford University ♦ School of Engineering
Biomedical Computation - Simulation Track
2014–2015 Program Sheet

Final version of completed and signed program due to the department no later than one month prior to the last quarter of senior year.

Follow all requirements as stated for the year of the program sheet used.

Name: _____ SU ID #: _____
 Phone: _____ Email: _____
 Today's Date: _____ Month/Yr B.S. expected: _____

Mathematics and Science Requirements

Dept	Course	Title	Transfer/AP Approval by SoE			Unit	Grade
			✓ if Transfer	SoE Initials	Date		
<i>Mathematics (21 units minimum)</i>							
MATH	41	Calculus				5	
MATH	42	Calculus				5	
		Probability: CS109 or STATS116 or MS&E120 or 220 or EE178 or CME106					
CS	103	Mathematical Foundations of Computing				5	
CS	161	Data Structures and Algorithms				4	
CME100 or MATH 51		Advanced Calculus I				5	
<i>Mathematics Unit Total (21 units minimum)</i>							

Science (17 units minimum)

PHYS	41	Mechanics				4	
CHEM 31A&B or 31X or ENGR 31		Chemical Principles (regular sequence or accelerated)				10 or 4	
CHEM	33	Structure & Reactivity				5	
BIO41 or HUMBIO2A		Biology or Human Biology Core I				5	
BIO42 or HUMBIO3A		Biology or Human Biology Core II				5	
BIO43 or HUMBIO4A		Biology or Human Biology Core III				5	
<i>Science Unit Total (17 units minimum)</i>							
<i>Math + Science Total (41 units minimum)</i>							

Technology in Society Requirement (1 course required; see UGHB, Fig. 3-3 for approved list)

--	--	--	--	--	--	--	--

Engineering Fundamentals (2 courses required)

CS	106B or X	Programming Abstractions				5	
ENGR	30	Eng. Thermodynamics				3	
<i>Engineering Fundamentals Total</i>							

NOTES

- * **All courses taken for the major must be taken for a letter grade if that option is offered by the instructor.**
- * This form is available as an Excel file at <http://ughb.stanford.edu/>; you must use a program sheet from a year you are enrolled at Stanford. The printed form must be signed by the advisor and, if required, by the departmental representative. Changes must be initialed by your advisor or dept in ink.
- * Read all emails from your major department; this is the School's only effective method of communicating with you.
- * Minimum Combined Grade Point Average for all courses in the major (combined) is 2.0.
- * Transfer & AP credits in Math, Science, Funds., & TIS must be approved by the SoE Dean's office. Transfer credits in Engr Depth must be approved by the Advisor. Information & petitions at <http://ughb.stanford.edu/>
- * All courses listed on this form must only be included under one category. Delete courses not taken.

Simulation program sheet continued

BMC Depth (42 units minimum; see note 1)

Dept	Course	Title	Transfer/Deviation Approval by Advisor			Units	Grade
			✓ if Transfer	Advisor Initials	Date		
Additional BMC Core requirements							
CS	107	Programming Paradigms				5	
CS270, CS273A, CS274, CS275, CS278, or CS279		Capstone Class - select one					
(any department)		Independent Research (see note 2)				6	
CS191W, E199W, or CS272		WIM (if not already satisfied by Independent Research - see note 2)					

Track Core (5 courses required)

CME102 or Math53		Advanced Calculus II				5	
ENGR	80	Introduction to Bioengineering				4	
BIOE	101	Systems Biology				4	
BIOE	103	Systems Physiology and Design				4	

Track Depth (6 courses required)

Simulation Electives (2 courses required: see note 4)

						3	
						3	

Cellular/Molecular Elective (1 course required: see note 3)

						3	
--	--	--	--	--	--	---	--

Organs/Organ Systems Elective (1 courses required: see note 3)

						3	
--	--	--	--	--	--	---	--

Simulation, Organs, or Cell/Mol Elective (2 course required: see note 3)

						3	
						3	

BMC Depth Total (Total of all units on this page) (42 units minimum)

Program Totals

Mathematics and Science (41 units minimum)

BMC Depth Total (Total of all units on this page) (42 units minimum)

Engineering (Fundamentals + Depth) Units (see note 2) (40 units minimum)

Program Approvals

Advisor

Printed Name: _____

Date: _____

Signature: _____

Departmental

Printed Name: _____

Date: _____

Signature: _____

School of Engineering (No action required-office use only)

Printed Name: _____

Date: _____

Signature: _____

NOTES (continued from page 1)

- (1) 40 units of engineering courses are required, to be met through the Engr Fundamentals and BMC Depth courses.
- (2) Students must complete 6 units of BMC research in any department, with project approval from BMC program coordinators. Research can satisfy WIM if student enrolls in CS191W or E199W. See bmc.stanford.edu for details.
- (3) The list of electives is continually updated to include all applicable courses. For the current list of electives, please visit <http://bmc.stanford.edu>. Electives may only be listed once on program sheet; no double-counting.

Stanford University ♦ School of Engineering
Biomedical Computation - Cellular/Molecular Track
2014–2015 Program Sheet

Final version of completed and signed program due to the department no later than one month prior to the last quarter of senior year.

Follow all requirements as stated for the year of the program sheet used.

Name: _____ SU ID #: _____
 Phone: _____ Email: _____
 Today's Date: _____ Month/Yr B.S. expected: _____

Mathematics and Science Requirements

Dept	Course	Title	Transfer/AP Approval by SoE			Unit	Grade
			✓ if Transfer	SoE Initials	Date		
<i>Mathematics (21 units minimum)</i>							
MATH	41	Calculus				5	
MATH	42	Calculus				5	
		Probability: CS109 or STATS116 or MS&E120 or 220 or EE178 or CME106					
CS	103	Mathematical Foundations of Computing				5	
CS	161	Data Structures and Algorithms				4	
CME100, MATH 51, or STAT 141		Advanced Calculus or Biostatistics				5	
<i>Mathematics Unit Total (21 units minimum)</i>							

Science (17 units minimum)

PHYS	41	Mechanics				4	
CHEM 31A&B or X or ENGR 31		Chemical Principles (regular seq. or accelerated)					
CHEM	33	Structure & Reactivity				5	
BIO41 or HUMBIO2A		Biology or Human Biology Core I				5	
BIO42 or HUMBIO3A		Biology or Human Biology Core II				5	
BIO43 or HUMBIO4A		Biology or Human Biology Core III				5	
<i>Science Unit Total (17 units minimum)</i>							
<i>Math + Science Total (41 units minimum)</i>							

Technology in Society Requirement (1 course required; see UGHB, Fig. 3-3 for approved list)

--	--	--	--	--	--	--	--

Engineering Fundamentals (2 courses required)

CS	106B or X	Programming Abstractions				5	
		Elective (see note 1; CS 106A not allowed)					
<i>Engineering Fundamentals Total</i>							

NOTES

- * **All courses taken for the major must be taken for a letter grade if that option is offered by the instructor.**
 - * This form is available as an Excel file at <http://ughb.stanford.edu/>; you must use a program sheet from a year you are enrolled at Stanford. The printed form must be signed by the advisor and, if required, by the departmental representative. Changes must be initialed by your advisor or dept in ink.
 - * Read all emails from your major department; this is the School's only effective method of communicating with you.
 - * Minimum Combined Grade Point Average for all courses in the major (combined) is 2.0.
 - * Transfer & AP credits in Math, Science, Funds., & TIS must be approved by the SoE Dean's office. Transfer credits in Engr Depth must be approved by the Advisor. Information & petitions at <http://ughb.stanford.edu/>
 - * All courses listed on this form must only be included under one category. Delete courses not taken.
- (1) One course required, 3 to 5 units. CS 106A not allowed; See Engr Fundamentals list in Chap 3 of UGHB for alternatives.

BMC Cellular/Molecular Depth (42 units minimum; delete courses not taken. See note 2)

Dept	Course	Title	Transfer/Deviation Approval by Advisor			Units	Grade
			✓ if Transfer	Advisor Initials	Date		
Additional BMC Core requirements							
CS	107	Programming Paradigms				5	
CS270, CS273A, CS274, CS275, CS278, or CS279		Capstone Class - select one					
(any department)		Independent Research (see note 3)				6	
CS191W, E199W, or CS272		WIM (if not already satisfied by Independent Research - see note 3)					

Track Core (4 courses required)

BIO	129A	Cellular Dynamics I				4	
BIO	129B	Cellular Dynamics II				4	
BIO 188 or CHEM 135 or 171		Biochemistry or Physical Chemistry				3	
BIO 203 or 118		Genetics					

Track Depth (5 courses required)

Informatics Electives (1 course required: see note 4)

						3	
--	--	--	--	--	--	---	--

Simulation Electives (1 course required: see note 4)

						3	
--	--	--	--	--	--	---	--

Informatics or Simulation Electives (2 course required: see note 4)

Informatics, Simulation, or Cell/Mol Elective (1 course required: see note 4)

						3	
--	--	--	--	--	--	---	--

BMC Depth Total (Total of all units on this page) (42 units minimum)
Engineering (Fundamentals + Depth) Units (see note 2) (40 units minimum)

Program Approvals

Advisor

Printed Name: _____ Date: _____
 Signature: _____

Departmental

Printed Name: _____ Date: _____
 Signature: _____

School of Engineering (No action required-office use only)

Printed Name: _____ Date: _____
 Signature: _____

NOTES (continued from page 1)

- (2) 40 units of engineering courses are required, to be met through the Engr Fundamentals and BMC Depth courses.
- (3) Students must complete 6 units of BMC research in any department, with project approval from BMC program coordinators. Research can satisfy WIM if student enrolls in CS191W or E199W. See bmc.stanford.edu for details.
- (4) The list of electives is continually updated to include all applicable courses. For the current list of electives, please visit <http://bmc.stanford.edu>. Electives may only be listed once on program sheet; no double-counting.

Stanford University ♦ School of Engineering
Biomedical Computation - Organs and Organisms Track
2014–2015 Program Sheet

Final version of completed and signed program due to the department no later than one month prior to the last quarter of senior year.

Follow all requirements as stated for the year of the program sheet used.

Name: _____ SU ID #: _____
 Phone: _____ Email: _____
 Today's Date: _____ Month/Yr B.S. expected: _____

Mathematics and Science Requirements

Dept	Course	Title	Transfer/AP Approval by SoE			Unit	Grade
			✓ if Transfer	SoE Initials	Date		
<i>Mathematics (21 units minimum)</i>							
MATH	41	Calculus				5	
MATH	42	Calculus				5	
		Probability: CS109 or STATS116 or MS&E120 or 220 or EE178 or CME106					
CS	103	Mathematical Foundations of Computing				5	
CS	161	Data Structures and Algorithms				4	
CME100, MATH 51, or STATS141		Advanced Calculus or Biostatistics				5	
<i>Mathematics Unit Total (21 units minimum)</i>							
<i>Science (17 units minimum)</i>							
PHYS	41	Mechanics				4	
CHEM 31A&B or X or ENGR 31		Chemical Principles (regular seq. or accelerated)					
CHEM	33	Structure & Reactivity				5	
BIO41 or HUMBIO2A		Biology or Human Biology Core I				5	
BIO42 or HUMBIO3A		Biology or Human Biology Core II				5	
BIO43 or HUMBIO4A		Biology or Human Biology Core III				5	
<i>Science Unit Total (17 units minimum)</i>							
<i>Math + Science Total (41 units minimum)</i>							

Technology in Society Requirement (1 course required; see UGHB, Fig. 3-3 for approved list)

--	--	--	--	--	--	--

Engineering Fundamentals (2 courses required)

CS	106B or X	Programming Abstractions				5	
		Elective (see note 1; CS 106A not allowed)					
<i>Engineering Fundamentals Total</i>							

NOTES

- * **All courses taken for the major must be taken for a letter grade if that option is offered by the instructor.**
 - * This form is available as an Excel file at <http://ughb.stanford.edu/>; you must use a program sheet from a year you are enrolled at Stanford. The printed form must be signed by the advisor and, if required, by the departmental representative. Changes must be initialed by your advisor or dept in ink.
 - * Read all emails from your major department; this is the School's only effective method of communicating with you.
 - * Minimum Combined Grade Point Average for all courses in the major (combined) is 2.0.
 - * Transfer & AP credits in Math, Science, Funds., & TIS must be approved by the SoE Dean's office. Transfer credits in Engr Depth must be approved by the Advisor. Information & petitions at <http://ughb.stanford.edu/>
 - * All courses listed on this form must only be included under one category. Delete courses not taken.
- (1) One course required, 3 to 5 units. CS 106A not allowed; See Engr Fundamentals list in Chap 3 of UGHB for alternatives.

BMC Organ & Organisms Depth (42 units minimum; see note 2)

Dept	Course	Title	Transfer/Deviation Approval by Advisor			Units	Grade
			✓ if Transfer	Advisor Initials	Date		
Additional BMC Core requirements							
CS	107	Programming Paradigms				5	
CS270, CS273A, CS274, CS275, CS278, or CS279		Capstone Class - select one					
(any department)		Independent Research (see note 3)				6	
CS191W, E199W, or CS272		WIM (if not already satisfied by Independent Research see note 3)					
Track Core (2 courses required)							
BIO	112	Human Physiology				4	
BIO 188 or BioE/Rad 220		Biochemistry or Introduction to Imaging				3	
Track Depth (7 courses required)							
<i>Organs/Organ Systems Elective (2 courses required: see note 4)</i>							
						3	
						3	
<i>Informatics Electives (1 course required: see note 4)</i>							
						3	
<i>Simulation Electives (1 course required: see note 4)</i>							
						3	
<i>Informatics or Simulation Electives (2 course required: see note 4)</i>							
<i>Informatics, Simulation, or Organs/Organ Systems Elective (1 course required: see note 4)</i>							
						3	

BMC Depth Total (Total of all units on this page) (42 units minimum)

Program Totals

Mathematics and Science (41 units minimum)

BMC Depth Total (Total of all units on this page) (42 units minimum)

Engineering (Fundamentals + Depth) Units (see note 2) (40 units minimum)

Program Approvals

Advisor

Printed Name: _____ Date: _____

Signature: _____

Departmental

Printed Name: _____ Date: _____

Signature: _____

School of Engineering (No action required-office use only)

Printed Name: _____ Date: _____

Signature: _____

NOTES (continued from page 1)

- (2) 40 units of engineering courses are required, to be met through the Engr Fundamentals and BMC Depth courses.
- (3) Students must complete 6 units of BMC research in any department, with project approval from BMC program coordinators. Research can satisfy WIM if student enrolls in CS191W or E199W. See bmc.stanford.edu for details.
- (4) The list of electives is continually updated to include all applicable courses. For the current list of electives, please visit <http://bmc.stanford.edu>. Electives may only be listed once on program sheet; no double-counting.

CHEMICAL ENGINEERING

— ABET ACCREDITATION CRITERIA APPLY —

Chemical Engineering is a discipline that relates to numerous areas of technology. In broad terms, chemical engineers are responsible for the conception and design of processes for the purpose of production, transformation, and transport of biochemicals, chemicals, energy, and materials. More recently, chemical engineers are increasingly involved in the design of new products that are enabled by emerging process technologies. These activities begin with experimentation in the laboratory and are followed by implementation of the technology to full-scale production. The mission of the Chemical Engineering department at Stanford is to provide professional training, development, and education for the next generation of leaders in chemical sciences and engineering.

The large number of industries that depend on the synthesis and processing of chemicals and materials place the chemical engineer in great demand. In addition to traditional examples such as the chemical, energy and oil industries, opportunities in biotechnology, pharmaceuticals, electronic materials and device fabrication, and environmental engineering are increasing. The unique training of the chemical engineer becomes essential in these areas whenever processes involve the chemical or physical transformation of matter. For example, chemical engineers working in the chemical industry investigate the creation of new polymeric materials with important electrical, optical, or mechanical properties. This requires attention not only to the synthesis of the polymer, but also to the flow and forming processes necessary to create a final product. In biotechnology, chemical engineers have responsibilities in the design of production processes and facilities to use microorganisms and enzymes to synthesize new drugs. Chemical engineers also solve environmental problems by developing technology and processes, such as catalytic converters and effluent treatment facilities, to minimize the release of products harmful to the environment.

To carry out these activities, the chemical engineer requires a complete and quantitative understanding of both the scientific and engineering principles underlying these technological processes. This is reflected in the curriculum of the chemical engineering department, which includes the study of applied mathematics, material and energy balances, thermodynamics, fluid mechanics, energy and mass transfer, separations technologies, chemical reaction kinetics and

reactor design, biochemical engineering and process design. Courses are built on a foundation in the sciences of chemistry, physics, and biology.

The individual student's mathematics and science course preparation for the chemical engineering major depends on his or her previous background in these areas. Following are six representative sequences or 4-year plans. Recommended plans 1A, 1B, 2, or 3 or alternative math plans 5 and 6 start at different points but all conclude with the same in-the-major depth requirements and completion of degree requirements. Plan 4 is representative of the schedule of courses for students approved for honors research, which requires a minimum of 12 units in addition to the normal requirements for the major.

Representative programs with the recommended engineering math (CME) courses:

- #1A Little preparation in math and chemistry: This plan starts with MATH 19, 20, 21, and CHEM 31A & 31B.
- #1B Little preparation in math; strong chemistry: This plan starts with MATH 19, 20, 21 and CHEM 31X.
- #2 No AP math credits, prepared to start with MATH 40 series, then move to CME math series. Strong chemistry preparation; start with CHEM 31X.
- #3 AP math credits, prepared to start with the CME math series, which is recommended instead of the MATH 50 series. Start with CHEM 31X.
- #4 Same preparation as #3, but with a degree goal of a B.S. with Honors in Chemical Engineering. This departmental Honors Program is by application only; see departmental student services. This plan is for students interested in an in-depth research experience in addition to the normal coursework for the major.

Alternative programs with MATH 50 series courses (require an additional 5 units of math):

- #5 No AP math credits, starting with MATH 40 series and continuing preparation with MATH 50 series.
- #6 AP math credits for MATH 40 series; start with MATH 50 series.

Our departmental website is at <http://cheme.stanford.edu/> and that of our student chapter of the American Institute of Chemical Engineers is at <http://www.stanford.edu/group/aiche/>. Our faculty, staff, and students would be glad to talk with you about majoring in Chemical Engineering. If you would like more information about this major, please contact our departmental student services staff in Shriram Center, room 129.

Alternatively, you may phone (650-723-4306) or email Pamela R. Dixon at prdixon@stanford.edu.

OBJECTIVES AND OUTCOMES FOR CHEMICAL ENGINEERING

Objectives:

1. Graduates will be effective in applying the basic chemical engineering principles along with analytical problem-solving and communication skills necessary to succeed in diverse careers including chemical engineering practice and academic research.
2. Graduates will be effective life-long learners especially in a field whose focus areas, tools, and professional and societal expectations are constantly changing.
3. Graduates will be equipped to successfully pursue postgraduate study whether in engineering or in other fields.
4. Graduates will consider the broader context of social, environmental, economic and safety issues and demonstrate high standards of professional and ethical responsibility to become responsible citizens and leaders in the community and in the field of chemical science.

Outcomes:

- (a) An ability to apply knowledge of mathematics, science, and engineering.
- (b) An ability to design and conduct experiments as well as analyze and interpret data.
- (c) An ability to design a system, component, or process to meet desired needs within realistic constraints such as economic, environmental, social, political, ethical, health and safety, manufacturability, and sustainability.
- (d) An ability to function on multidisciplinary teams.
- (e) An ability to identify, formulate, and solve engineering problems.
- (f) An understanding of professional and ethical responsibility.
- (g) An ability to communicate effectively.
- (h) The broad education necessary to understand the impact of engineering solutions in a global, economic, environmental, and societal context.
- (i) A recognition of the need for and engage in life-long learning.
- (j) A knowledge of contemporary issues.
- (k) An ability to use the techniques, skills, and modern engineering tools necessary for engineering practice.
- (l) An acquisition of the background for admission to engineering or other professional graduate programs.

INSTRUCTIONS FOR FINDING OUT MORE ABOUT THE CHEMICAL ENGINEERING MAJOR

1. Contact Chemical Engineering Student Services. Drop-in visits are encouraged, especially Wed/Thurs/Fri from 2:30 and 4:00 p.m. in Shriram Center, room 129. To make an appointment with the student services administrator, send an email to Pamela R. Dixon at prdixon@stanford.edu. We encourage you to let the department know that you are considering the major so we can give you an opportunity to ask questions and get more information about chemical engineering, our advising program, summer internships, year-round research opportunities, and so forth.
2. Attend the annual ChemE advising symposium the first week of classes, autumn quarter.

- Attend monthly departmental advising sessions.
- Meet one-on-one with chemical engineering faculty and/or students.

REQUIREMENTS: CHEMICAL ENGINEERING PROGRAM

Course	Title	Total	Qtr.	Year
Mathematics and Science (47-53 Units)				
MATH 41	Single Variable Calculus	5	A	Fr
MATH 42	Single Variable Calculus	5	A,W	Fr
CME 100* <i>or</i> Math 51 AND 52	Vector Calculus for Engineers	5	A,S	Fr, So
CME 102* <i>or</i> Math 53	Ordinary Differential Equations for Engineers	5	A,W,S	Fr, So
CME 104 <i>or</i> CME 106 (1 of 2 req'd)	Linear Algebra & Partial Differential Equations for ENGRs Intro to Probability and Statistics for Engineers	5 4	S W	So/Jr So/Jr
CHEM 31X <i>or</i>	Chemical Principles (req'd) (or CHEM 31A and CHEM B)	5	A	Fr
CHEM 33	Structure and Reactivity (req'd)	5	W, S	Fr
CHEM 35	Organic Monofunctional Compounds (req'd)	5	S	Fr
CHEM 36	Organic Chemistry Lab -- now replaced by new CHEM 35)	3	S	Fr
CHEM 131	Organic Polyfunctional Compounds	3	A,W	So
PHYS 41	Mechanics (req'd)	4	W	So
PHYS 43	Electricity & Magnetism (req'd)	4	S	So
<i>*CME 100 and 102 are the recommended math courses for ChemE majors</i>				
Technology in Society (3-5 units) (select one course from the approved list; see Chap 3, Figure 3-3)				
Engineering Fundamentals (3 courses minimum)				
ENGR 20	Introduction to Chemical Engineering	3	S	Fr/So
ENGR 25B <i>or</i> 25E	Biotechnology <i>or</i> Energy: Chemical Transformations for Production, Storage, & Use	3 3	S W	Fr/So Fr/So
<i>Select 25B or 25E plus one or more additional Fundamentals course(s). May not use a second version of ENGR 25 for the elective; see Chapter 3, Figure 3-4 for list of alternative courses</i>				
CHEME Professional Requirement (1 unit does not apply to the 68-unit minimum for ABET)				
CHEMENG 10	The Chemical Engineering Profession	1	A	Sr
Engineering Depth (59 units; Note: Engineering Fundamentals and Depth combined must equal a minimum of 68 units in order to meet ABET graduation requirements)				
CHEMENG 100	Chem. Process Modeling, Dynamics	3	A	Jr
CHEMENG 110	Equilibrium Thermodynamics	3	W	Jr
CHEMENG 120A	Fluid Mechanics	4	W	Jr
CHEMENG 120B	Energy & Mass Transport	4	S	Jr
CHEMENG 130	Separation Processes	3	S	Jr
CHEMENG 150	Biochemical Engineering	3	W	Sr
Take 2:	<i>You must take two of these required depth electives; do not combine 160 & 162:</i>			
CHEMENG 140 <i>or</i>	Micro & Nanoscale Fabrication Engineering	3	W	Sr
CHEMENG 142 <i>or</i>	Catalysis with Applications in Energy Transformations	3	S	Sr
CHEMENG 160 <i>or</i>	Polymer Science & Engineering	3	W	Sr
CHEMENG 162 <i>or</i>	Polymers for Energy & Environmental Sustainability	3	W	Sr
CHEMENG 174 <i>or</i>	Environmental Microbiology I	3	A	Sr
CHEMENG 183 <i>or</i>	Biochemistry II	3	W	Jr
CHEMENG 196	Entrepreneurship in Engineering & Science-based Industries	3	A	Sr
CHEMENG 170	Kinetics and Reactor Design	3	A	Sr

CHEMENG 180	Chemical Engineering Plant Design	4	S	Sr
CHEMENG 181	Biochemistry I	3	A	Jr
CHEMENG 185A	Chemical Engineering Lab A (<i>satisfies WIM</i>)	4	A	Sr
CHEMENG 185B	Chemical Engineering Lab B	4	W	Sr
CHEM 171	Physical Chemistry – Chemical Thermodynamics	3	S	So
CHEM 173	Physical Chemistry – Quantum Chemistry	3	A	Jr
CHEM 175	Physical Chemistry – Kinetic Theory & Statistical Mechanics	3	W	Jr

Chemical Engineering

Typical Sequence of Courses

4-Year Plan # 1-A

MATH 19, 29, 21 series; then CME 100, 102, and Engineering Math Elective (CME 104 or CME 106)

Plan 1-A = CHEM 31A and CHEM 31B, instead of CHEM 31X

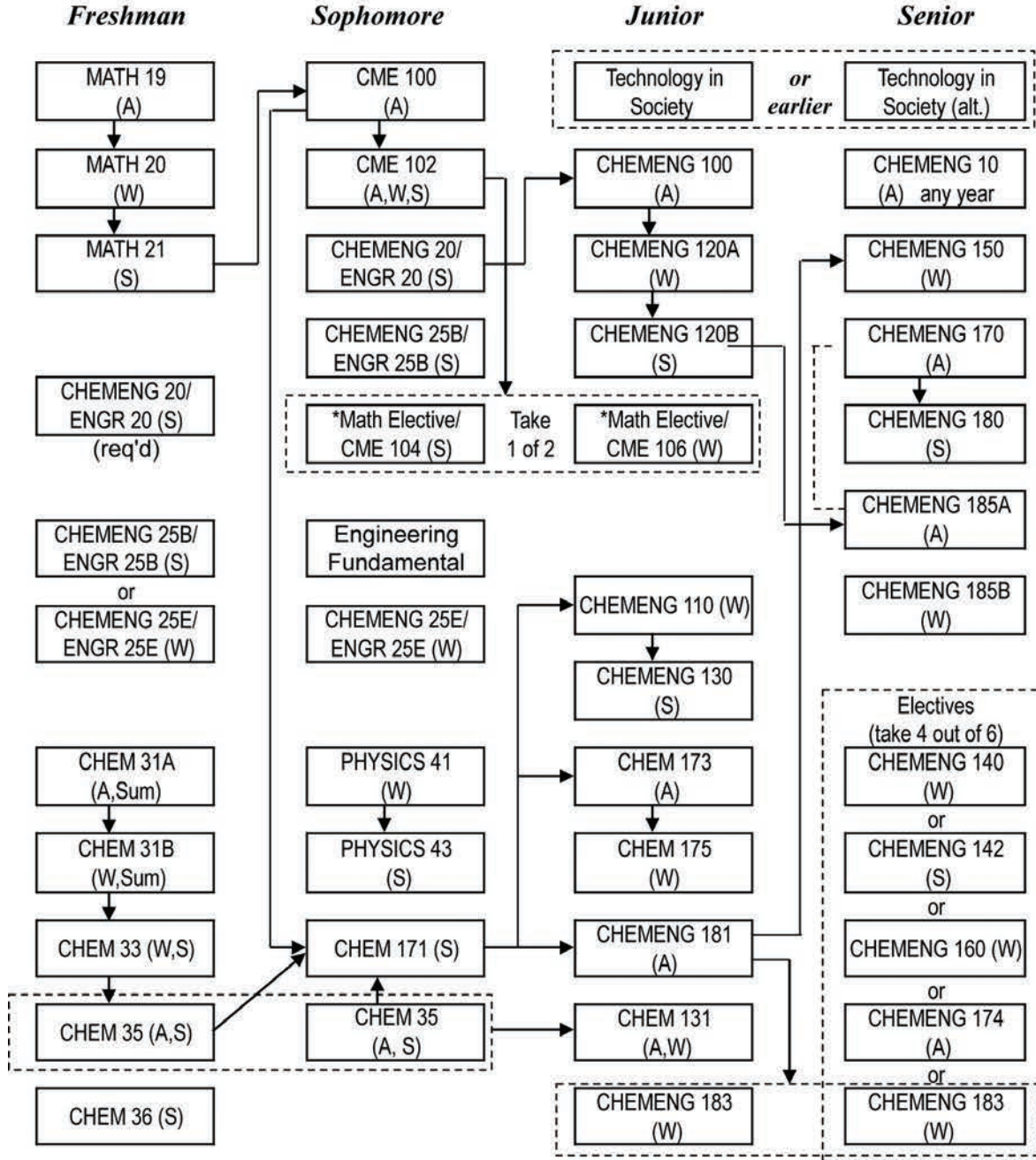

* Solid arrows represent direct prerequisites.

* Dashed lines represent co-requisites.

* Dashed-line boxes enclose alternatives. These may indicate years in which to take a given course or different courses that may fulfill a degree requirement.

Chemical Engineering

4-Year Plan #1A: CHEM 31A & B (instead of CHEM 31X) and MATH 19, 20, 21 series. Then CME 100, 102, and CME 104 or 106.

*** Note: Final Program MUST have a total of 68 units of Engineering Fundamentals and Depth for ABET requirements. ***

	Fall				Winter				Spring			
	Class	Math/ Sci.	Engr	Other	Class	Math/ Sci.	Engr	Other	Class	Math/ Sci.	Engr	Other
<i>Freshman</i>	MATH 19	3	-	-	MATH 20	3	-	-	MATH 21	4	-	-
	THINK	-	-	4	WAYS	-	-	3	WAYS	-	-	3
	WAYS	-	-	3	Writing	-	-	4	CHEM 33	5	-	-
	CHEM 31A*	5	-	-	CHEM 31B*	5	-	-	ENGR 20 **	-	3	-
					ENGR 25E **	-	-	-				
	<i>Subtotals</i>	8	0	7	<i>Subtotals</i>	8	0	7	<i>Subtotals</i>	9	3	3
	Total			15	Total			15	Total			15
<i>Sophomore</i>	CME 100	5	-	-	CME 102	5	-	-	ENGR 20 **	-	-	-
	WAYS	-	-	3	Engr. Fund.	-	4	-	ENGR 25B **	-	3	-
	CHEM 35	5	-	-	PHYSICS 41	4	-	-	PHYSICS 43	4	-	-
					Writing	-	-	4	CHEM 171	-	3	-
	CHEM 131	3							WAYS	-	-	3
	<i>Subtotals</i>	15	0	3	<i>Subtotals</i>	9	4	4	<i>Subtotals</i>	4	6	3
	Total			18	Total			17	Total			13
<i>Junior</i>	CHEMENG 100	-	3	-	CHEMENG 110	-	3	-	CHEMENG 130	-	3	-
	CHEM 173	-	3	-	CHEMENG 120A	-	4	-	CHEMENG 120B	-	4	-
	CHEMENG 181	-	3	-	CHEM 175	-	3	-	ENGR math elec	5	-	-
	Language	-	-	5	Language	-	-	5	Language	-	-	5
					ENGR math elec	-	-	-	WAYS	-	-	3
	<i>Subtotals</i>	0	9	5	<i>Subtotals</i>	0	10	5	<i>Subtotals</i>	5	7	8
	Total			14	Total			15	Total			20
<i>Senior</i>	WAYS	-	-	3	CHEMENG 140	-	-	-	TIS course ***	-	-	4
	CHEMENG 170	-	3	-	CHEMENG 150	-	3	-	CHEMENG 180	-	4	-
	CHEMENG 185A	-	4	-	CHEMENG 185B	-	4	-	CHEMENG 142	-	3	-
	CHEMENG 10	-	-	1	CHEMENG 183	-	3	-	WAYS	-	-	3
	CHEMENG 174	-	3	-	CHEMENG 160	-	3	-	WAYS	-	-	3
	<i>Subtotals</i>	0	10	4	<i>Subtotals</i>	0	13	3	<i>Subtotals</i>	0	7	10
	Total			14	Total			16	Total			17

Notes:

AP Math Units:	0
UG Math & Science Units:	58
Total Engineering Units:	69
Total Other Units:	62
Total Units:	189

Both CHEMENG 185A and 185B required

* If prepared, take CHEM 31X, CHEM 33, and CHEM 35, 36

** ENGR/CHEMENG 20 and one of ENGR/CHEMENG 25B or ENGR/CHEMENG 25E required

*** TIS course in 2nd, 3rd, or 4th year

- ENGR math elective, one of two: CME 104 (5 units) or CME 106 (4 units).

ChE electives: Select four from CHEMENG 140, 142, 160, 162, 174, 183, except combining 160 & 162. See program sheet for more choices

➔ The School of ENGR encourages a quarter abroad. For detail on in-person or online ENGR course options see the Overseas Programs & Engineers page on the UGHB website or Chap 8 of the UGHB.

- Students' choices for Math elective, 3rd Engineering Fundamental, and CHEMENG electives affect choices, units, and scheduling of GER courses and other courses not required for the ChemE major.

Chemical Engineering

Typical Sequence of Courses

4-Year Plan # 1-B

MATH 19, 29, 21 series; then CME 100, 102, and Engineering Math Elective (CME 104 or CME 106)

Plan 1-B = CHEM 31X instead of CHEM 31A and CHEM 31B

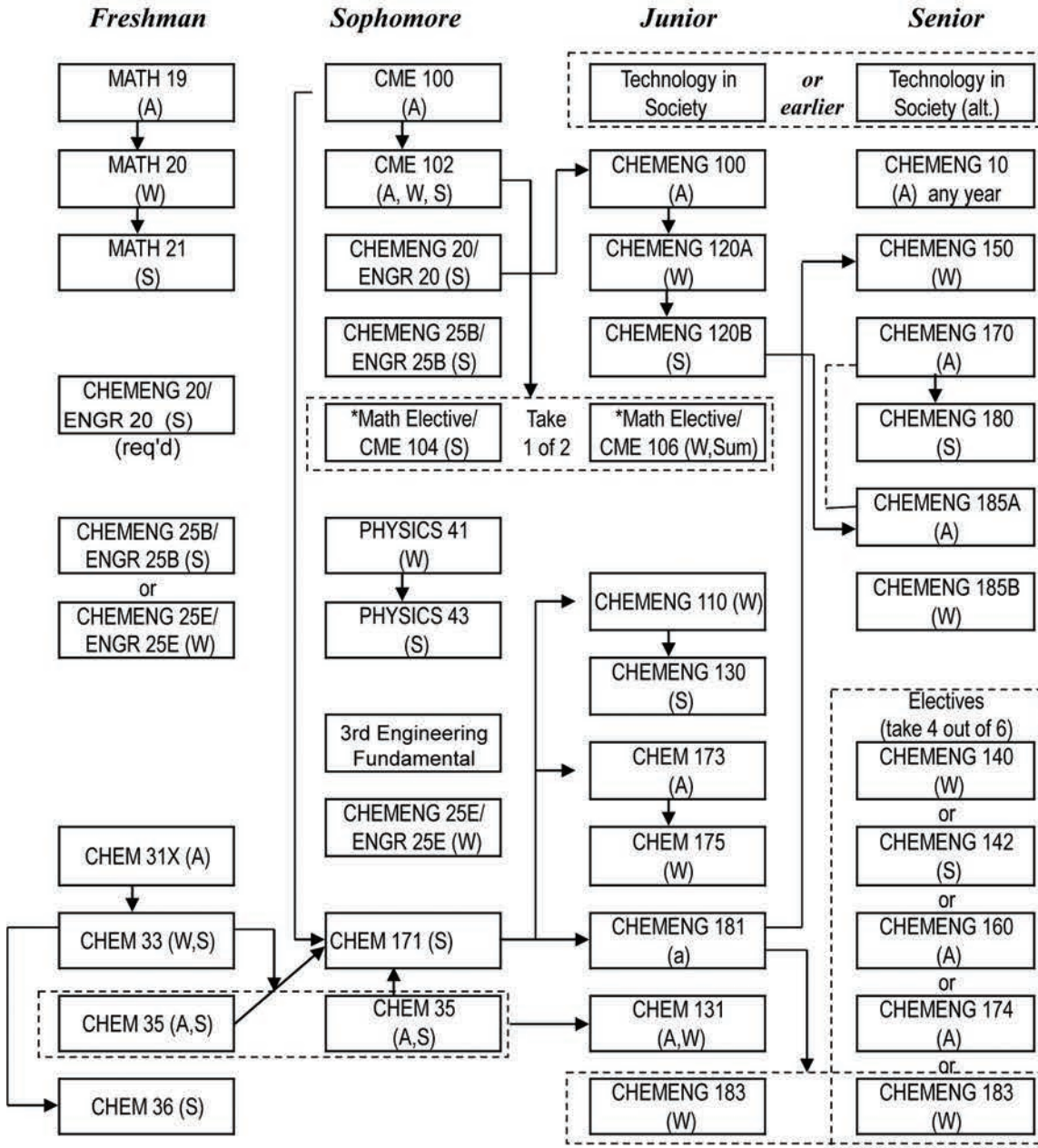

* Solid arrows represent direct prerequisites.

* Dashed lines represent co-requisites.

* Dashed-line boxes enclose alternatives. These may indicate years in which to take a given course or different courses that may fulfill a degree requirement.

Chemical Engineering

4-Year Plan # 1-B: CHEM 31X (instead of CHEM 31A & B) and MATH 19, 20, 21 series. Then CME 100, 102, and 104 or 106

*** Note: Final Program MUST have a total of 68 units of Engineering Fundamentals and Depth for ABET requirements. ***

	Fall				Winter				Spring			
	Math/				Math/				Math/			
	Class	Sci.	Engr	Other	Class	Sci.	Engr	Other	Class	Sci.	Engr	Other
<i>Freshman</i>	MATH 19	3	-	-	MATH 20	3	-	-	MATH 21	4	-	-
	THINK	-	-	4	WAYS	-	-	3	WAYS	-	-	3
	WAYS	-	-	3	Writing	-	-	4	CHEM 35	5	-	-
	CHEM 31X	5	-	-	CHEM 33	5	-	-	ENGR 20 **	-	-	-
	ENGR 25E **	-	-	-	Subtotals	8	0	7	Subtotals	11	0	3
	Subtotals	8	0	7	Subtotals	8	0	7	Subtotals	11	0	3
	Total	15			Total	15			Total	14		
<i>Sophomore</i>	CME 100	5	-	-	CME 102	5	-	-	ENGR 20 **	-	3	-
	WAYS	-	-	3	Writing	-	-	4	ENGR 25B **	-	3	-
	CHEM 131	3	-	-	PHYSICS 41	4	-	-	PHYSICS 43	4	-	-
	Engr. Fund.	-	4	-	WAYS	-	-	3	CHEM 171	-	3	-
	WAYS	-	-	3	Subtotals	9	0	7	Subtotals	4	9	3
	Subtotals	8	4	3	Subtotals	9	0	7	Subtotals	4	9	3
	Total	15			Total	16			Total	16		
<i>Junior</i>	CHEMENG 100	-	3	-	CHEMENG 110	-	3	-	CHEMENG 130	-	3	-
	WAYS	-	-	3	CHEMENG 120A	-	4	-	CHEMENG 120B	-	4	-
	CHEM 173	-	3	-	CHEM 175	-	3	-	ENGR Math elec	5	-	-
	CHEMENG 181	-	3	-	Language	-	-	5	Language	-	-	5
	Language	-	-	5	Subtotals	0	10	5	Subtotals	5	7	5
	Subtotals	0	9	8	Subtotals	0	10	5	Subtotals	5	7	5
	Total	17			Total	15			Total	17		
<i>Senior</i>	WAYS	-	-	3	CHEMENG 140	-	3	-	TIS course ***	-	-	4
	CHEMENG 170	-	3	-	CHEMENG 150	-	3	-	CHEMENG 180	-	4	-
	CHEMENG 185A	-	4	-	CHEMENG 185B	-	4	-	CHEMENG 142	-	3	-
	CHEMENG 10	-	-	1	CHEMENG 183	-	3	-	WAYS	-	-	3
	WAYS	-	-	3	CHEMENG 160	-	3	-	WAYS	-	-	3
	TIS *** (alt)	-	-	-	Subtotals	0	16	0	Subtotals	0	7	10
	Subtotals	0	7	7	Subtotals	0	16	0	Subtotals	0	7	10
	Total	14			Total	16			Total	17		

Notes:

AP Math Units:	0
UG Math & Science Units:	53
Total Engineering Units:	69
Total Other Units:	65
Total Units:	187

Both CHEMENG 185A and 185B required

** ENGR/CHEMENG 20 and one of ENGR/CHEMENG 25B or ENGR/CHEMENG 25E required

*** TIS course in 2nd, 3rd, or 4th year

- ENGR math elective, one of two: CME 104 (5 units) or CME 106 (4 units).

→ The School of ENGR encourages a quarter abroad. For detail on in-person or online ENGR course options see the Overseas Programs & Engineers page on the UGHB website or Chap 8 of the UGHB.

ChE electives: Select four from CHEMENG 140, 142, 160, 162, 174, 183, except combining 160 & 162. See program sheet for more choices

- Students' choices for Math elective, 3rd Engineering Fundamental, and CHEMENG electives affect choices, units, and scheduling of GER courses and other courses not required for the ChemE major.

Chemical Engineering

Typical Sequence of Courses

4-Year Plan # 2 — RECOMMENDED

MATH 40 series, then CME 100, 102 then CME 104 or 106

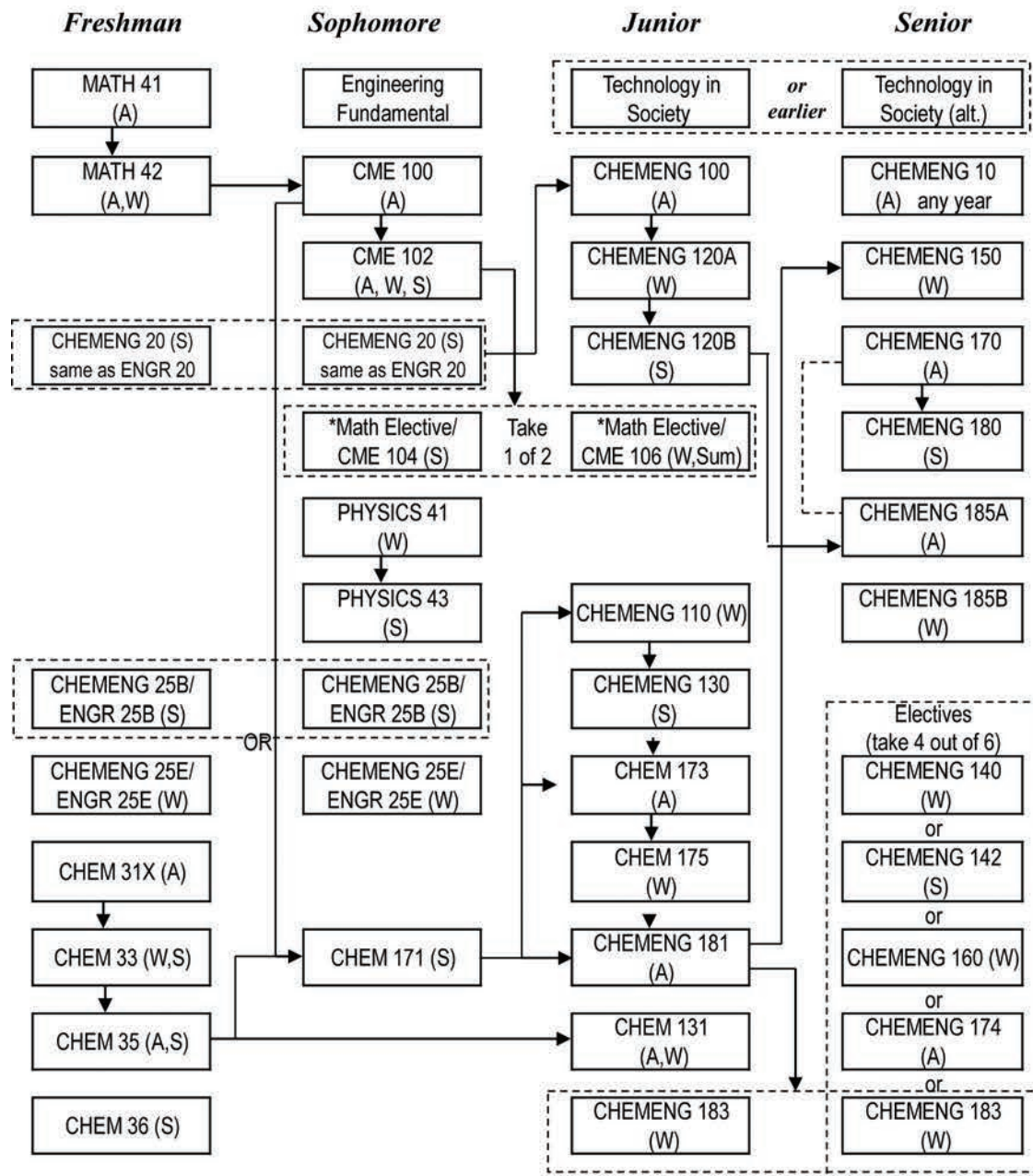

* Solid arrows represent direct prerequisites.

* Dashed lines represent co-requisites.

* Dashed-line boxes enclose alternatives. These may indicate years in which to take a given course or different courses that may fulfill a degree requirement.

Chemical Engineering

4-Year Plan # 2 — A RECOMMENDED PLAN — MATH 40 series; then CME 100 and 102. Then CME 104 or 106

*** Note: Final Program MUST have a total of 68 units of Engineering Fundamentals and Depth for ABET requirements. ***

	Fall				Winter				Spring			
	Math/				Math/				Math/			
	Class	Sci.	Engr	Other	Class	Sci.	Engr	Other	Class	Sci.	Engr	Other
<i>Freshman</i>	MATH 41	5	-	-	MATH 42	5	-	-	ENGR 20 **	-	3	-
	THINK	-	-	4	WAYS	-	-	3	ENGR 25B **	-	-	-
	CHEM 31X	5	-	-	CHEM 33	5	-	-	WAYS	-	-	3
	WAYS	-	-	3	Writing	-	-	4	CHEM 35	5	-	-
					ENGR 25E **	-	-	-				
	<i>Subtotals</i>	10	0	7	<i>Subtotals</i>	9	0	7	<i>Subtotals</i>	7	3	3
	Total			17	Total			16	Total			13
<i>Sophomore</i>	CME 100	5	-	-	CME 102	5	-	-	ENGR 20 **	-	-	-
	CHEM 131	3	-	-	Writing	-	-	4	ENGR 25B **	-	3	-
	Engr. Fund.	-	4	-	PHYSICS 41	4	-	-	PHYSICS 43	4	-	-
	WAYS	-	-	3	WAYS	-	-	3	CHEM 171	-	3	-
	TIS ***	-	-	5	ENGR 25E **	-	-	-	WAYS	-	-	3
				WAYS	-	-	3					
	<i>Subtotals</i>	8	4	8	<i>Subtotals</i>	9	0	7	<i>Subtotals</i>	4	6	3
	Total			20	Total			16	Total			13
<i>Junior</i>	CHEMENG 100	-	3	-	CHEMENG 110	-	3	-	CHEMENG 130	-	3	-
	Elective	-	-	3	CHEMENG 120A	-	4	-	CHEMENG 120B	-	4	-
	CHEM 173	-	3	-	CHEM 175	-	3	-	ENGR math elec	5	-	-
	CHEMENG 181	-	3	-	ENGR math elec	-	-	-	WAYS	-	-	3
	TIS *** (alt.)	-	-	-	CHEMENG 183	-	-	-				
				WAYS	-	-	3					
	<i>Subtotals</i>	0	9	3	<i>Subtotals</i>	0	10	0	<i>Subtotals</i>	5	7	3
	Total			12	Total			10	Total			15
<i>Senior</i>	CHEMENG 174	-	3	-	CHEMENG 140	-	3	-	WAYS	-	-	3
	CHEMENG 170	-	3	-	CHEMENG 150	-	3	-	CHEMENG 180	-	4	-
	CHEMENG 185A	-	4	-	CHEMENG 185B	-	4	-	Language	-	-	5
	CHEMENG 10	-	-	1	CHEMENG 160	-	3	-	Elective	-	-	5
	Language	-	-	5	Language	-	-	5	TIS *** (alt.)	-	-	-
				WAYS	-	-	3	CHEMENG 142	-	-	-	
	<i>Subtotals</i>	0	10	6	<i>Subtotals</i>	0	16	5	<i>Subtotals</i>	0	4	13
	Total			16	Total			21	Total			17

Notes:

AP Math Units:	0
UG Math & Science Units:	52
Total Engineering Units:	69
Total Other Units:	65
Total Units:	186

Both CHEMENG 185A and 185B required

** ENGR/CHEMENG 20 and one of ENGR/CHEMENG 25B or ENGR/CHEMENG 25E required

*** TIS course in 2nd, 3rd, or 4th year

- ENGR math elective, one of two: CME 104 (5 units) or CME 106 (4 units).
- ChE electives: Select four from CHEMENG 140, 142, 160, 162, 174, 183, except combining 160 & 162. See program sheet for more choices.
- ➔ The School of ENGR encourages a quarter abroad. For detail on in-person or online ENGR course options see the Overseas Programs & Engineers page on the UGHB website or Chap 8 of the UGHB.
- Students' choices for Math elective, 3rd Engineering Fundamental, and CHEMENG electives affect choices, units, and scheduling of GER courses and other courses not required for the ChemE major.

Chemical Engineering

Typical Sequence of Courses

4-Year Plan # 3 — RECOMMENDED

AP credit for MATH 40 series; start with CME 100, 102 (instead of MATH 51 series); then CME 104 or 106

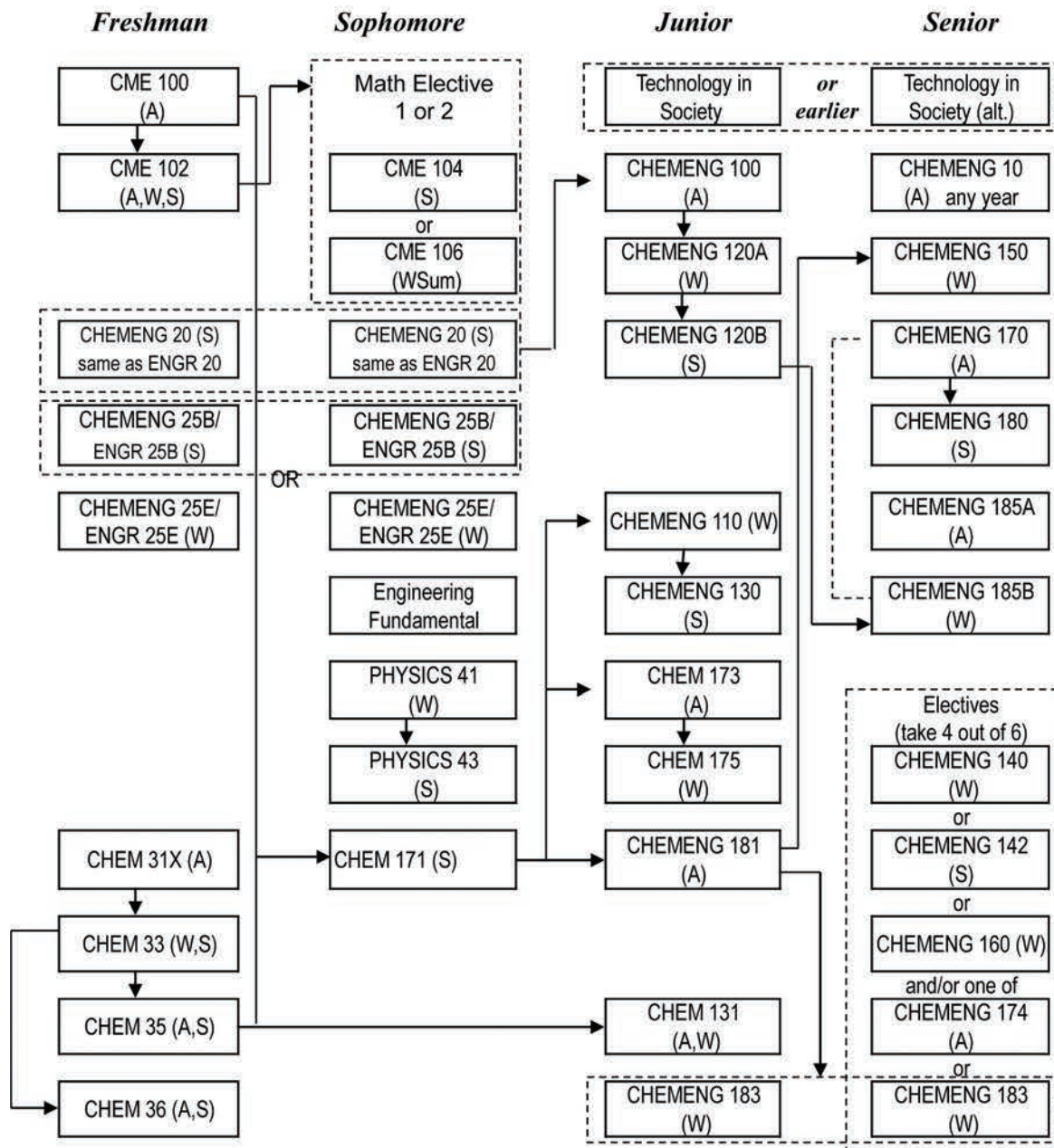

* Solid arrows represent direct prerequisites.

* Dashed lines represent co-requisites.

* Dashed-line boxes enclose alternatives. These may indicate years in which to take a given course or different courses that may fulfill a degree requirement.

Chemical Engineering

4-Year Plan # 3 — A RECOMMENDED PLAN — CME 100 and 102, then CME 104 or 106

(AP credit for MATH 40 series; start with CME 100, 102 instead of MATH 51 series)

*** Note: Final Program MUST have a total of 68 units of Engineering Fundamentals and Depth for ABET requirements. ***

	<i>Fall</i>				<i>Winter</i>				<i>Spring</i>			
	Math/ Sci.	Engr	Other		Math/ Sci.	Engr	Other		Math/ Sci.	Engr	Other	
<i>Freshman</i>	Class				Class				Class			
	CME 100	5	-	-	CME 102	5	-	-	ENGR 20 **	-	3	-
	THINK	-	-	4	THINK (opt)	-	-	4	ENGR 25B **	-	-	-
	CHEM 31X	5	-	-	CHEM 33	5	-	-	WAYS	-	-	3
	WAYS	-	-	3	Writing	-	-	4	CHEM 35	5	-	-
	<i>Subtotals</i>	<i>10</i>	<i>0</i>	<i>7</i>	<i>Subtotals</i>	<i>10</i>	<i>0</i>	<i>11</i>	<i>Subtotals</i>	<i>8</i>	<i>3</i>	<i>3</i>
	Total			17	Total			21	Total			14
<i>Sophomore</i>	CHEM 131	3	-	-	CME math elec	4	-	-	CME math elec	-	-	-
	TIS *** (alt.)	-	-	-	PHYSICS 41	4	-	-	PHYSICS 43	4	-	-
	Engr. Fund	-	4	-	Writing	-	-	4	ENGR 20 **	-	-	-
	WAYS	-	-	3	ENGR 25E **	-	-	-	ENGR 25B **	-	3	-
	Language	-	-	5	Language	-	-	5	Language	-	-	5
	WAYS	-	-	3	WAYS	-	-	3	CHEM 171	-	3	-
	<i>Subtotals</i>	<i>3</i>	<i>4</i>	<i>11</i>	<i>Subtotals</i>	<i>8</i>	<i>0</i>	<i>12</i>	<i>Subtotals</i>	<i>4</i>	<i>6</i>	<i>5</i>
	Total			18	Total			20	Total			15
<i>Junior</i>	CHEMENG 100	-	3	-	CHEMENG 110	-	3	-	CHEMENG 130	-	3	-
	WAYS	-	-	3	CHEMENG 120A	-	4	-	CHEMENG 120B	-	4	-
	CHEM 173	-	3	-	CHEM 175	-	3	-	Elective	-	-	4
	CHEMENG 181	-	3	-	CHEMENG 183	-	3	-	WAYS	-	-	3
	<i>Subtotals</i>	<i>0</i>	<i>9</i>	<i>3</i>	<i>Subtotals</i>	<i>0</i>	<i>13</i>	<i>0</i>	<i>Subtotals</i>	<i>0</i>	<i>7</i>	<i>7</i>
	Total			12	Total			13	Total			14
<i>Senior</i>	CHEMENG 174	-	3	-	CHEMENG 140	-	3	-	WAYS	-	-	3
	CHEMENG 170	-	3	-	CHEMENG 150	-	3	-	CHEMENG 180	-	4	-
	CHEMENG 185A	-	4	-	CHEMENG 185B	-	4	-	Elective	-	-	3
	CHEMENG 10	-	-	1	WAYS	-	-	3	CHEMENG 142	-	-	-
	TIS course ***	-	-	4	CHEMENG 160	-	3	-	WAYS	-	-	3
	<i>Subtotals</i>	<i>0</i>	<i>10</i>	<i>5</i>	<i>Subtotals</i>	<i>0</i>	<i>13</i>	<i>3</i>	<i>Subtotals</i>	<i>0</i>	<i>4</i>	<i>9</i>
	Total			15	Total			16	Total			13

Notes:

AP Math Units: 10
 UG Math & Science Units: 43
 Total Engineering Units: 69
 Total Other Units: 76
Total Units: 198

Both CHEMENG 185A and 185B required

** ENGR/CHEMENG 20 and one of ENGR/CHEMENG 25B or ENGR/CHEMENG 25E required

*** TIS course in 2nd, 3rd, or 4th year

- ENGR math elective, one of two: CME 104 (5 units) or CME 106 (4 units).
- ChE electives: Select four from CHEMENG 140, 142, 160, 162, 174, 183, except combining 160 & 162. See program sheet for more choices.
- Students' choices for Math elective, 3rd Engineering Fundamental, and CHEMENG electives affect choices, units, and scheduling of GER courses and other courses not required for the ChemE major.

Chemical Engineering with Honors Research

Typical Sequence of Courses

4-Year Plan # 4 — RECOMMENDED

AP credit for MATH 40 series; start with CME 100, 102, instead of MATH 51 series

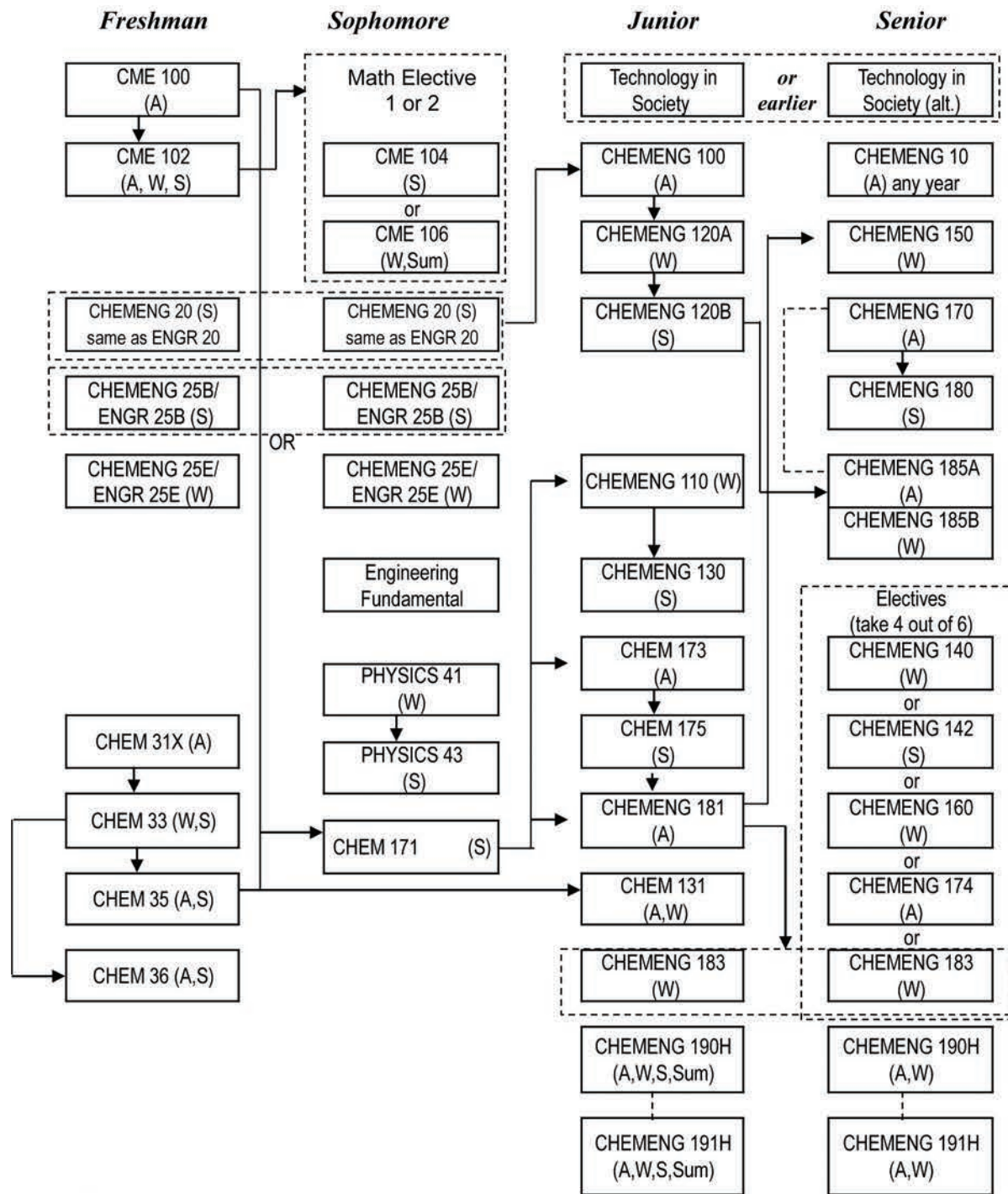

* Solid arrows represent direct prerequisites.

* Dashed lines represent co-requisites.

* Dashed-line boxes enclose alternatives. These may indicate years in which to take a given course or different courses that may fulfill a degree requirement.

Chemical Engineering WITH HONORS

Requires add'l dept application with research proposal; min. 3.5 GPA; min. of 9 units of 190H during min. of 3 quarters + min. of 3 units of 191H

4-Year Plan # 4 — A RECOMMENDED PLAN — CME 100, 102, & 104 or 106. (AP credit for MATH 41/42. CME instead of MATH series)

*** Note: Final Program MUST have a total of 68 units of Engineering Fundamentals and Depth for ABET requirements. ***

	Fall				Winter				Spring			
	Math/				Math/				Math/			
	Class	Sci.	Engr	Other	Class	Sci.	Engr	Other	Class	Sci.	Engr	Other
<i>Freshman</i>	CME 100	5	-	-	CME 102	5	-	-	ENGR 20 **	-	3	-
	THINK	-	-	4	WAYS	-	-	3	WAYS	-	-	4
	CHEM 31X	5	-	-	CHEM 33	5	-	-	CHEM 35	5	-	-
	WAYS	-	-	3	Writing	-	-	4				
	<i>Subtotals</i>	<i>10</i>	<i>0</i>	<i>7</i>	<i>Subtotals</i>	<i>10</i>	<i>0</i>	<i>7</i>	<i>Subtotals</i>	<i>8</i>	<i>3</i>	<i>3</i>
	Total			17	Total			17	Total			14
<i>Sophomore</i>	CHEM 131	3	-	-	CME math elec	-	-	-	CME math elec	5	-	-
	TIS *** (alt.)	-	-	-	PHYSICS 41	4	-	-	PHYSICS 43	4	-	-
	WAYS	-	-	3	Engr. Fund	-	4	-	ENGR 20 **	-	-	-
	WAYS	-	-	3	Writing	-	-	4	ENGR 25B **	-	3	-
	Language	-	-	5	Language	-	-	5	CHEM 171	-	3	-
					ENGR 25E **	-	-	-	WAYS	-	-	3
<i>Subtotals</i>	<i>3</i>	<i>0</i>	<i>11</i>	<i>Subtotals</i>	<i>4</i>	<i>4</i>	<i>9</i>	<i>Subtotals</i>	<i>9</i>	<i>6</i>	<i>3</i>	
	Total			14	Total			17	Total			18
<i>Junior</i>	CHEMENG 100	-	3	-	CHEMENG 110	-	3	-	CHEMENG 130	-	3	-
	TIS ** (alt.)	-	-	-	CHEMENG 120A	-	4	-	CHEMENG 120B	-	4	-
	CHEM 173	-	3	-	CHEM 175	-	3	-	Language	-	-	5
	WAYS	-	-	3	WAYS	-	-	3	CHEMENG 191H	-	1	-
	CHEMENG 181	-	3	-	CHEMENG 183	-	3	-	CHEMENG 190H	-	3	-
									WAYS	-	-	3
<i>Subtotals</i>	<i>0</i>	<i>9</i>	<i>3</i>	<i>Subtotals</i>	<i>0</i>	<i>13</i>	<i>3</i>	<i>Subtotals</i>	<i>0</i>	<i>11</i>	<i>5</i>	
	Total			12	Total			16	Total			16
<i>Senior</i>	CHEMENG 174	-	3	-	CHEMENG 140	-	-	-	TIS	-	-	3
	CHEMENG 170	-	3	-	CHEMENG 150	-	3	-	CHEMENG 180	-	4	-
	CHEMENG 185A	-	4	-	CHEMENG 185B	-	4	-	WAYS	-	-	3
	CHEMENG 10	-	-	1	TIS course **	-	-	4	Elective	-	-	3
	CHEMENG 190H	-	3	-	CHEMENG 190H	-	3	-	TIS** (alt.)	-	-	-
	CHEMENG 191H	-	1	-	CHEMENG 191H	-	1	-	CHEMENG 142	-	3	-
	WAYS	-	-	3	CHEMENG 160	-	3	-				
	<i>Subtotals</i>	<i>0</i>	<i>14</i>	<i>4</i>	<i>Subtotals</i>	<i>0</i>	<i>14</i>	<i>4</i>	<i>Subtotals</i>	<i>0</i>	<i>7</i>	<i>9</i>
	Total			18	Total			18	Total			16

Notes:

Both CHEMENG 185A and 185B required

** ENGR/CHEMENG 20 and one of ENGR/CHEMENG 25B or 25E required

*** TIS course in 2nd, 3rd, or 4th year

ENGR math elective, one of two: CME 104 or CME 106.

ChE electives: Select four from CHEMENG 140, 142, 160, 162, 174, 183, except combining 160 & 162. See program sheet for more choices

➔ The School of ENGR encourages a quarter abroad. For detail on in-person or online ENGR course options see the Overseas Programs & Engineers page on the UGHB website or Chap 8 of the UGHB.

- Students' choices for Math elective, 3rd Engineering Fundamental, and CHEMENG electives affect choices, units, and scheduling of GER/WAYS courses and other courses not required for the ChemE major.

AP Math Units:	10
UG Math & Science Units:	44
Total Engineering Units:	81
Total Other Units:	68
Total Units:	203

Chemical Engineering

Typical Sequence of Courses

4-Year Plan # 5

MATH 40 series, then MATH 50 series, then CME 104 or 106

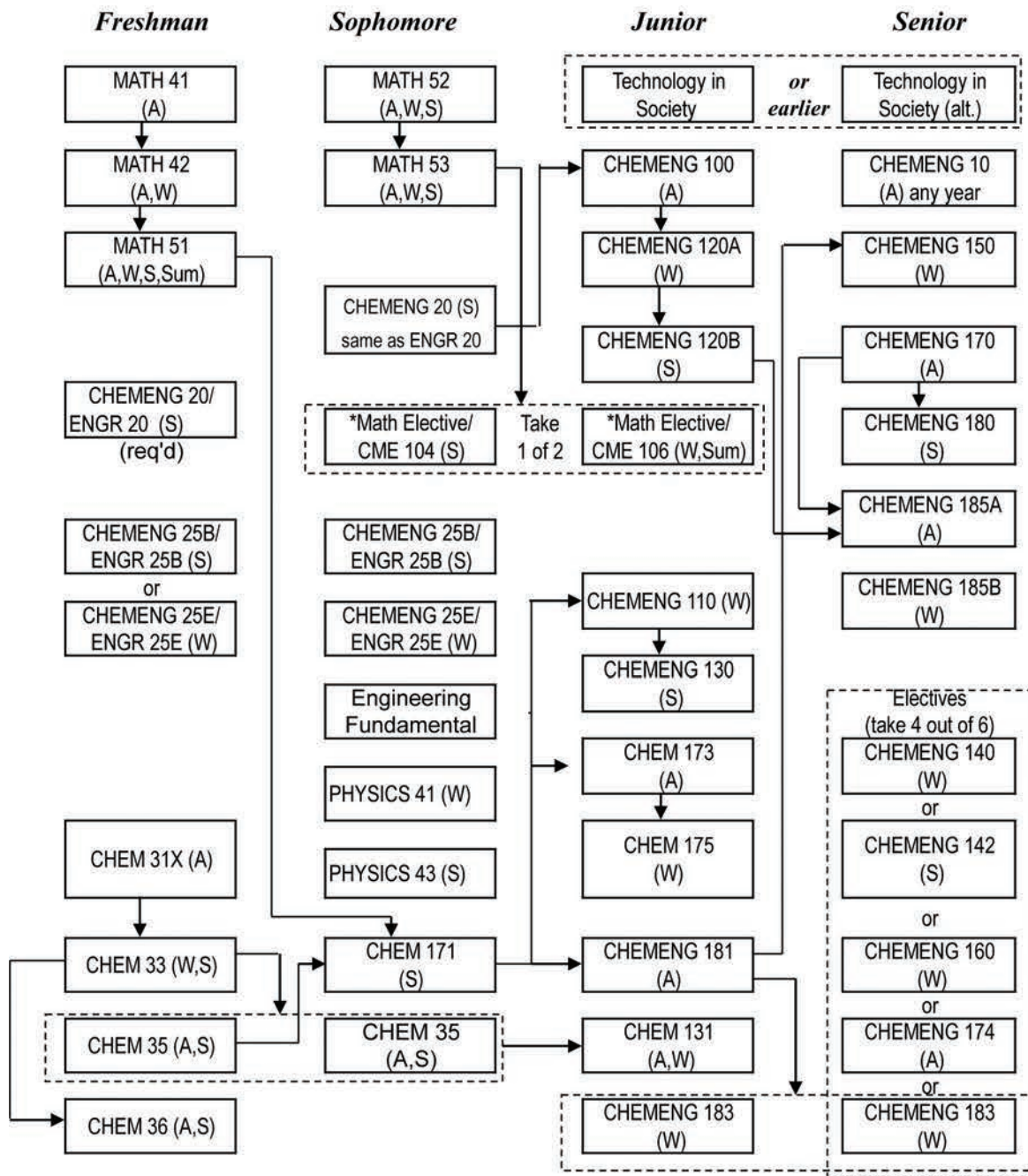

* Solid arrows represent direct prerequisites.

* Dashed lines represent co-requisites.

* Dashed-line boxes enclose alternatives. These may indicate years in which to take a given course or different courses that may fulfill a degree requirement.

Chemical Engineering

4-Year Plan # 5 — A PLAN that starts with MATH 41 & 42, then the MATH 51 series, followed by CME 104 or 106.

*** Note: Final Program MUST have a total of 68 units of Engineering Fundamentals and Depth for ABET requirements. ***

	Fall				Winter				Spring			
	Class	Math/ Sci.	Engr	Other	Class	Math/ Sci.	Engr	Other	Class	Math/ Sci.	Engr	Other
<i>Freshman</i>	MATH 41	5	-	-	MATH 42	5	-	-	MATH 51	5	-	-
	THINK	-	-	4	WAYS	-	-	3	WAYS	-	-	3
	CHEM 31X	5	-	-	CHEM 33	5	-	-	CHEM 35	5	-	-
	WAYS	-	-	3	Writing	-	-	4	ENGR 20 **	-	-	-
					ENGR 25E **	-	-	-				
	<i>Subtotals</i>	10	0	7	<i>Subtotals</i>	9	0	7	<i>Subtotals</i>	13	0	3
	Total			17	Total			16	Total			16
<i>Sophomore</i>	MATH 52	5	-	-	MATH 53	5	-	-	ENGR math elec	5	-	-
	CHEM 131	3	-	-	PHYSICS 41	4	-	-	PHYSICS 43	4	-	-
	Engr. Fund	-	4	-	Writing	-	-	4	ENGR 20 **	-	3	-
	WAYS	-	-	3	WAYS	-	-	3	ENGR 25B **	-	3	-
	TIS *** (alt.)	-	-	-	ENGR 25E **	-	-	-	CHEM 171	-	3	-
	<i>Subtotals</i>	8	4	3	<i>Subtotals</i>	9	0	7	<i>Subtotals</i>	9	9	0
	Total			15	Total			16	Total			18
<i>Junior</i>	CHEMENG 100	-	3	-	CHEMENG 110	-	3	-	CHEMENG 130	-	3	-
	Language	-	-	5	CHEMENG 120A	-	4	-	CHEMENG 120B	-	4	-
	CHEM 173	-	3	-	CHEM 175	-	3	-	Language	-	-	5
	WAYS	-	-	3	Language	-	-	5	WAYS	-	-	3
	CHEMENG 181	-	3	-	CHEMENG 183	-	3	-				
	<i>Subtotals</i>	0	9	8	<i>Subtotals</i>	0	13	8	<i>Subtotals</i>	0	7	8
	Total			17	Total			21	Total			15
<i>Senior</i>	TIS course ***	-	-	4	CHEMENG 140	-	3	-	TIS	-	-	-
	CHEMENG 170	-	3	-	CHEMENG 150	-	3	-	CHEMENG 180	-	4	-
	CHEMENG 185A	-	4	-	CHEMENG 185B	-	4	-	Elective	-	-	3
	CHEMENG 10	-	-	1	CHEMENG 160	-	3	-	Elective	-	-	3
	CHEMENG 174	-	3	-	WAYS	-	-	3	WAYS	-	-	3
	<i>Subtotals</i>	0	10	8	<i>Subtotals</i>	0	13	3	<i>Subtotals</i>	0	4	9
	Total			18	Total			16	Total			13

AP Math Units: 0

UG Math & Science Units: 58

Total Engineering Units: 69

Total Other Units: 71

Total Units: 198

Notes:

Both CHEMENG 185A and 185B required

** ENGR/CHEMENG 20 and one of ENGR/CHEMENG 25B or ENGR/CHEMENG 25E required

*** TIS course in 2nd, 3rd, or 4th year

- ENGR math elective, one of two: CME 104 (5 units) or CME 106 (4 units).

- ChE electives: Select four from CHEMENG 140, 142, 160, 162, 174, 183, except combining 160 & 162. See program sheet for more choices

➔ The School of ENGR encourages a quarter abroad. For detail on in-person or online ENGR course options see the Overseas Programs & Engineers page on the UGHB website or Chap 8 of the UGHB.

- Students' choices for Math elective, 3rd Engineering Fundamental, and CHEMENG electives affect choices, units, and scheduling of GER courses and other courses not required for the ChemE major.

Chemical Engineering

Typical Sequence of Courses

4-Year Plan # 6

AP credit for MATH 40 series; MATH 50 series; CME 104 or 106

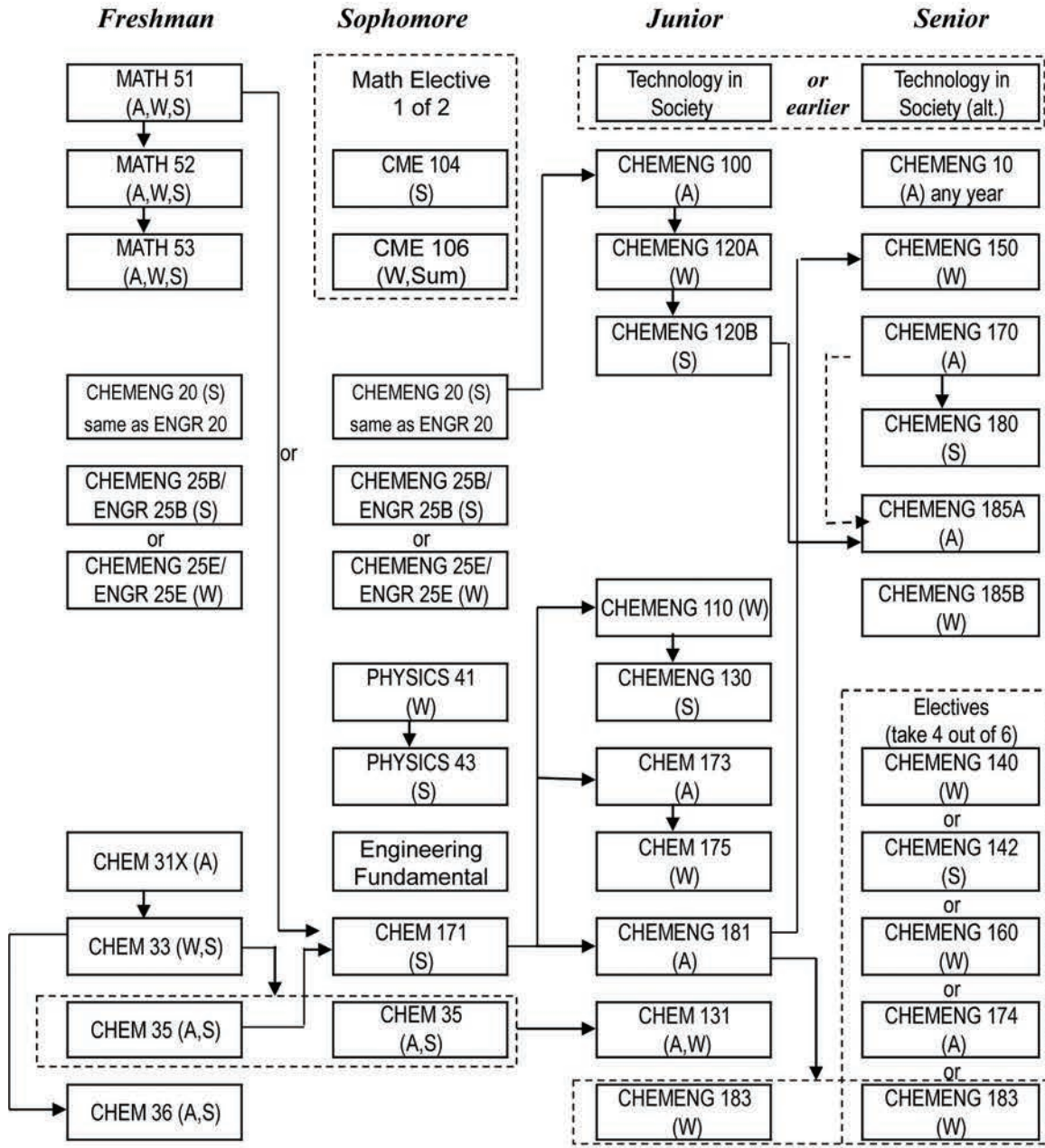

* Solid arrows represent direct prerequisites.

* Dashed lines represent co-requisites.

* Dashed-line boxes enclose alternatives. These may indicate years in which to take a given course or different courses that may fulfill a degree requirement.

Chemical Engineering

4-Year Plan # 6 — A PLAN with AP credit for the MATH 41 series, then the MATH 51 series, followed by CME 104 or 106

*** Note: Final Program MUST have a total of 68 units of Engineering Fundamentals and Depth for ABET requirements. ***

	Fall				Winter				Spring			
	Class	Math/ Sci.	Engr	Other	Class	Math/ Sci.	Engr	Other	Class	Math/ Sci.	Engr	Other
<i>Freshman</i>	MATH 51	5	-	-	MATH 52	5	-	-	MATH 53	5	-	-
	IntroSem	-	-	4	WAYS	-	-	3	CHEM 35	5	-	-
	CHEM 31X	5	-	-	CHEM 33	5	-	-			-	-
	WAYS	-	-	3	Writing	-	-	4	ENGR 20 **	-	-	-
					ENGR 25E **	-	-	-	ENGR 25B **	-	-	-
	<i>Subtotals</i>	10	0	7	<i>Subtotals</i>	10	0	7	<i>Subtotals</i>	13	0	3
	Total			17	Total			17	Total			16
<i>Sophomore</i>	CHEM 131	3	-	-	CME 104	5	-	-	ENGR math elec	5	-	-
	TIS course ***	-	-	4	PHYSICS 41	4	-	-	PHYSICS 43	4	-	-
	ENGR math elec	4	-	-	Engr. Fundamental	-	4	-	ENGR 20 **	-	3	-
	WAYS	-	-	3	Writing	-	-	4	ENGR 25B **	-	3	-
					ENGR 25E **	-	-	-	WAYS	-	-	3
	<i>Subtotals</i>	7	0	7	<i>Subtotals</i>	9	4	4	<i>Subtotals</i>	9	6	3
	Total			14	Total			17	Total			18
<i>Junior</i>	CHEMENG 100	-	3	-	CHEMENG 110	-	3	-	CHEMENG 130	-	3	-
	WAYS	-	-	3	CHEMENG 120A	-	4	-	CHEMENG 120B	-	4	-
	CHEM 171	-	3	-	CHEM 173	-	3	-	CHEM 175	-	3	-
	CHEMENG 181	-	3	-	TIS *** (alt.)	-	-	-	Language	-	-	5
	Language	-	-	5	Language	-	-	5	WAYS	-	-	3
				WAYS	-	-	3					
	<i>Subtotals</i>	0	9	5	<i>Subtotals</i>	0	10	5	<i>Subtotals</i>	0	10	8
	Total			14	Total			15	Total			18
<i>Senior</i>	WAYS	-	-	3	CHEMENG 140	-	3	-	WAYS	-	-	3
	CHEMENG 170	-	3	-	CHEMENG 150	-	3	-	CHEMENG 180	-	4	-
	CHEMENG 185A	-	4	-	CHEMENG 185B	-	4	-	WAYS	-	-	3
	CHEMENG 10	-	-	1	Elective	-	-	3	Elective	-	-	-
	CHEMENG 196	-	3	-	CHEMENG 183	-	3	-	TIS *** (alt.)	-	-	3
									CHEMENG 142	-	3	-
	<i>Subtotals</i>	0	10	4	<i>Subtotals</i>	0	13	3	<i>Subtotals</i>	0	7	9
	Total			14	Total			16	Total			16

Notes:

AP Math Units: 10
UG Math & Science Units: 58
Total Engineering Units: 69
Total Other Units: 65

Total Units: 202

Both CHEMENG 185A and 185B required

** ENGR/CHEMENG 20 and one of ENGR/CHEMENG 25B or ENGR/CHEMENG 25E required

*** TIS course in 2nd, 3rd, or 4th year

- ENGR math elective, one of two: CME 104 (5 units) or CME 106 (4 units).

ChE elective, select four from CHEMENG 140, 142, 160, 162, 174, 183, except combining 160 & 162. See program sheet for more choices

➔ The School of ENGR encourages a quarter abroad. For detail on in-person or online ENGR course options see the Overseas Programs & Engineers page on the UGHB website or Chap 8 of the UGHB.

- Students' choices for Math elective, 3rd Engineering Fundamental, and CHEMENG electives affect choices, units, and scheduling of GER courses and other courses not required for the ChemE major.

INSTRUCTIONS FOR DECLARING A MAJOR IN CHEMICAL ENGINEERING (CHEME-BS)

1. Log on to Axess and request to major in Chemical Engineering.
2. Print your unofficial Stanford transcript from Axess.
3. Download a Chemical Engineering Program Sheet in Excel from the School of Engineering web site: <http://ughb.stanford.edu> and complete it electronically. You must choose a program sheet from a year you were enrolled at Stanford. Enter “AP” instead of a course grade for any course waived due to AP credit.
4. Save the electronic file for your records. Print your Program Sheet.
5. Take your unofficial transcript and completed Program Sheet to Pamela Dixon, Student Services Administrator, in Shriram Center, room 129. She is generally available during the afternoon, Wed/Thurs/Fri, from 2:30 to 4:00 p.m.

Note: The online version of your major (link from the Home or Major Programs page of the UGHB website) is considered the definitive version of 2014-15 requirements; corrections or updates may have been made after the printed and pdf versions were published in August 2014.

★ You must use a program sheet from a year you have been enrolled at Stanford.

Stanford University's School of Engineering
Chemical Engineering
2014–2015 Program Sheet
— ABET Accreditation Criteria Apply —

Follow all requirements as stated for the year of the Program Sheet used.

Name: _____ SU ID #: _____
 Phone: _____ Email: _____
 Today's Date: _____ Month/Yr B.S. expected: _____

Mathematics and Science Requirement (45 units minimum)

Dept	Course	Title	Transfer/AP Approval by SoE			Units	Grade
			✓ if Transfer	SoE Initials	Date		
Mathematics							
MATH	41	Calculus (req'd)				5	
MATH	42	Calculus (req'd)				5	
CME	100	Vector Calculus for Engineers (req'd; note 1)				5	
CME	102	ODE for Engineers (req'd; note 1)				5	
CME 104 or CME 106		Linear Algebra & PDE for Engineers OR Intro. to Probability & Stats for Engineers (req'd)				5 4	
Mathematics Unit Total							

Science

PHYSICS	41	Mechanics (req'd)				4	
PHYSICS	43	Electricity & Magnetism (req'd)				4	
CHEM	31X	Chemical Principles (req'd) (or CHEM 31A+B 10 units)				5	
CHEM	33	Structure and Reactivity (req'd)				5	
CHEM	35	Synthetic & Physical Organic Chemistry (req'd)				5	
CHEM	131	Organic Polyfunctional Compounds (req'd)				3	
Science Unit Total							
Math & Science Unit Total (45 units minimum)							

Technology in Society Requirement (1 course required; see UGHB Fig. 3-3 for SoE approved list)

--	--	--	--	--	--	--	--

Engineering Fundamentals (3 courses required)

ENGR	20	Introduction to Chemical Engineering				3	
ENGR	25B or 25E	Biotechnology -or- Energy (see Note 2)				3	
ENGR		Fundamentals Elective (see UGHB for options; 2nd ENGR 25 course not allowed)					
Engineering Fundamentals Unit Total							

- * **All courses listed on this form must be taken for a letter grade if the option is offered by the instructor.**
 - * This form is available as an Excel file at <http://ughb.stanford.edu/>; you must use a program sheet from a year you are enrolled at Stanford. This printed form must be signed by the advisor and, if required, by the departmental representative.
 - * When filling out this form, delete courses and units not taken so totals will be correct.
 - * Minimum Combined GPA for all courses in Engineering Topics (Fundamentals and Depth courses) is 2.0.
 - * Transfer and AP credits in Math, Science, Funds., & TIS must be approved by the SoE Dean's Office. Transfer credits in Engineering Depth must be approved by the Advisor. Transfer credit information and petitions are available at <http://ughb.stanford.edu/t>
 - * All courses listed on this form must only be included under one category; no double-counting.
- (1) CME 100, 102 strongly recommended; however MATH 51 and 52 may be substituted for CME 100; MATH 53 may be substituted for CME 102. Students who have taken both Math 51&52 may not count CME100.
- (2) ENGR 20 AND either 25B or 25E are required. A second E 25 course may not be used as the Fundamental elective.

Engineering Topics (Fundamentals + Depth combined) must equal 68 units; see note 3

Dept	Course	Title	Transfer/AP Approval			Units	Grade
			Transfer	Initials	Date		
CHEMENG	10	The Chemical Engineering Profession	Does not apply to 68 unit min.			1	

Engineering Depth (Delete courses not taken)

CHEMENG	100	Chem. Proc. Modeling, Dyn. & Control				3	
CHEMENG	110	Equilibrium Thermodynamics				3	
CHEMENG	120A	Fluid Mechanics				4	
CHEMENG	120B	Energy and Mass Transport				4	
CHEMENG	130	Separation Processes				3	
CHEMENG	140	Micro/Nanoscale Fabrication Engineering (see note 4)				3	
CHEMENG	142	Catalysis (see note 4)				3	
CHEMENG	150	Biochemical Engineering				3	
CHEMENG	160	Polymer Science & Engineering (see Note 4)				3	
CHEMENG	162	Polymers Energy & Enviro Sustainability (see note 4)				3	
CHEMENG	170	Kinetics and Reactor Design				3	
CHEMENG	174	Environmental Microbiology (see Note 4)				3	
CHEMENG	180	Chemical Engineering Plant Design				4	
CHEMENG	181	Biochemistry I				3	
CHEMENG	183	Biochemistry II (see Note 4)				3	
CHEMENG	185A	Chemical Engineering Lab A (WIM)				4	
CHEMENG	185B	Chemical Engineering Lab B				4	
CHEMENG	196	Entrepreneurship in Engr & Sci Indus. (see note 4)				3	
CHEM	171	Physical Chemistry - Chem. Thermo.				3	
CHEM	173	Physical Chemistry - Quantum Chem.				3	
CHEM	175	Physical Chem - Kin. Th. & Stat. Mech.				3	

Engineering Depth Unit Totals

Program Totals

Mathematics and Science (45 units minimum)

Engineering Topics (Fundamentals + Depth) (68 units minimum)

Program Approvals

Advisor

Printed Name: _____
Signature: _____

Date: _____

Student Services/Departmental

Printed Name: _____
Signature: _____

Date: _____

School of Engineering (No action required-office use only)

Printed Name: _____
Signature: _____

Date: _____

NOTES (continued from page 1)

- (3) In order to satisfy ABET requirements for graduation, the ChemE major must take enough courses so that the combined units from Funds & Depth courses add up to a minimum of 68 units. CHEMENG 10 does not apply to the 68-unit min.
- (4) Select four of these required depth electives (140, 142, 160, 162, 174, 183, 196); do not combine 160 & 162. Students can use a combination of the following **substitutions** for up to two depth electives:
 - CHEMENG190 and/or CHEMENG190H (up to 3 units)
 - One or two 100-level course(s) offered in one of the following engineering disciplines: BIOE, CEE, CME, CS, EE, MS&E, MATSCI, and ME (must be taken for a minimum of 3 units ea.). May not use an independent or individual research or directed study course.
 Note: If a course is cross listed, you must enroll in the **engineering** course.
Cross out or delete any courses not taken. Replace if another course has been **substituted**.

CIVIL ENGINEERING

— ABET ACCREDITATION CRITERIA APPLY —

Civil engineers plan, design, construct and sustain the built environment including buildings and bridges, transportation and utility lifeline systems, energy and industrial facilities, and ports and waterways. Civil engineers work to protect society from natural catastrophes, such as earthquakes and hurricanes, as well as help manage our water and energy resources. As their work is crucial to the day-to-day lives of most people, civil engineers bear an important responsibility to the public.

The civil engineering field is both technical and people-oriented, requiring excellent communication skills and an ability to manage both people and multi-faceted projects. Students in the major learn to apply knowledge of mathematics, science, and the primary areas of civil engineering to conduct experiments, design systems to solve engineering problems, and communicate their ideas effectively to the scientific community.

OBJECTIVES AND OUTCOMES FOR CIVIL ENGINEERING

Objectives: Graduates of the civil engineering program are expected within a few years of graduation to have the ability to:

1. Establish themselves as practicing professionals in civil engineering or a related field
2. Pursue graduate study in civil engineering or other fields
3. Work effectively as responsible professionals alone or in teams handling increasingly complex professional and societal expectations

Outcomes:

- (a) An ability to apply knowledge of mathematics, science, and engineering
- (b) An ability to design and conduct experiments, as well as to analyze and interpret data
- (c) An ability to design a system, component, or process to meet desired needs within realistic constraints such as economic, environmental, social, political, ethical, health and safety, manufacturability, and sustainability
- (d) An ability to function on multi-disciplinary teams
- (e) An ability to identify, formulate, and solve engineering problems
- (f) An understanding of professional and ethical responsibility
- (g) An ability to communicate effectively
- (h) The broad education necessary to understand the impact of engineering solutions in a global, economic, environmental, and societal context
- (i) A recognition of the need for, and an ability to engage in life-long learning
- (j) A knowledge of contemporary issues
- (k) An ability to use the techniques, skills, and modern engineering tools necessary for engineering practice
- (l) Background for admission to engineering or other professional graduate programs

THE CURRICULUM

The undergraduate civil engineering curriculum includes a core to be taken by all declared majors that provides a broad introduction to the major areas of civil engineering. One of two tracks, selected by the student, is then followed to allow for specialized course work in either *Structures and Construction* or *Environmental and Water Studies*. Undergraduates potentially interested in the *Environmental and Water Studies* specialization of the Civil Engineering major should also consider the Environmental Systems Engineering major as a possible alternative; a comparison of these two alternative majors is presented in the Environmental Systems Engineering section on pg 228.

For more information on civil engineering, students are encouraged to visit the CEE website, talk to a CEE faculty member, or contact the CEE Student Services Specialist, Jill Filice, in room 316 of the Jerry Yang and Akiko Yamazaki Environment & Energy (Y2E2) Building.

RESEARCH EXPERIENCE FOR UNDERGRADUATES

The department of Civil and Environmental Engineering welcomes student participation in the VPUE Undergraduate Research Programs. Interested students should check the VPUE website and the CEE website for announcements regarding the application procedures. Annual program announcements appear in January with application due dates in February.

EXPLORING CIVIL ENGINEERING AS A MAJOR

Are you wondering whether a Civil Engineering major is for you? If so, here is some advice on courses accessible early in your undergraduate career that will help you explore your interest in our major. If you end up joining our program, this early start on fulfilling requirements will pay off by giving you more flexibility in class scheduling for your junior and senior years.

1. For an introduction to Civil Engineering, classes required for all of our declared majors that are readily accessible to you are:
 - ENGR 14: Introduction to Solid Mechanics (A,W,S)
 - ENGR 90 (same as CEE 70): Environmental Science & Technology (A)
 - CEE 100: Managing Sustainable Building Projects (A)(WIM)

- For electives providing additional exposure to the two tracks within our major, try

STRUCTURES AND CONSTRUCTION TRACK:

- CEE 29N: Managing Natural Disaster Risk (W; Freshman seminar)
- CEE 31Q: Accessing Architecture through Drawing (A,W; Sophomore seminar)
- CEE 48N: Managing Complex Global Projects (not given 14-15)
- CEE 109: Creating a Green Student Workforce to Help Implement Stanford's Sustainable Vision (not given 14-15)
- CEE 110A: Building Modeling Workshop (A)

ENVIRONMENTAL AND WATER STUDIES TRACK:

- CEE 63: Weather and Storms (A)
- CEE 64: Air Pollution and Global Warming: History, Science & Solutions (W)
- CEE 50N: Multidiscipl. Perspectives on a Large Urban Estuary: San Francisco Bay (not given 14-15)
- CEE 109: Creating a Green Student Workforce to Help Implement Stanford's Sustainable Vision (not given 14-15)
- CEE 166D: Water Resources and Water Hazards Field Trips (W)

- The following Science/Math classes are required for almost all majors within the School of Engineering:

- CHEM 31A or CHEM 31X or ENGR 31: Chemical Principles (A)
- PHYSICS 41: Mechanics (W) [pre-req: MATH 41; co-req: MATH 42] or 4 units of AP Physics C
- MATH 51: Linear Algebra and Differential Calculus (A,W,S) or CME 100: Vector Calculus (A,S), [prerequisite: MATH 41 and 42 or 10 units AP Calculus]

- Additional Science/Math classes required for students majoring in Civil Engineering that can readily be taken early on include:

- GES 1A (S), 1B (A) or 1C (not given 2014-15): Introduction to Geology (one course required for both CE tracks)
- STATS 110 (or STATS 60 or EESS 160 or CME 106): Statistics (A, W, S: required for both CE tracks)

Requirements: 2014-15 CIVIL ENGINEERING MAJOR

MATHEMATICS AND SCIENCE (45 UNITS MINIMUM), INCLUDING:

Course	Title	Units	Qtr
MATH 41/42	Calculus (or 10 units AP Calculus)	10	A/A,W
CME 100 & 102	Math/Computational Methods for Engineers (or Math 51 & 53)	10	A,S/W,S
PHYSICS 41	Mechanics (or 4 units AP Physics C)	4	W
CHEM 31A or 31X or ENGR 31	Chemical Principles	4-5	A
CHEM/PHYS	Chemistry and/or Physics proficiency (Note 1)	7-10	A,W,S
GES 1A or B	Intro to Earth Sciences (different topics in different quarters; count only one; see Note 2)	4-5	A,,S
STATS 110	Statistical Methods (or STAT 60 or EESS 160 or CEE 203 or CME 106)	3-5	A, Sum

(1) To achieve proficiency in Chemistry/Physics, students in the Environmental and Water Studies track are required to take CHEM 33 and one additional chemistry or physics course. If CHEM 31A is taken for the Chemical Principles requirement, CHEM 31B must be taken prior to CHEM 33 and it may count as the additional chemistry course. We recommend that students take CHEM 35 or CHEM 135 if they intend to continue on to graduate school in environmental studies. Students in the Structures and Construction track are required to take PHYSICS 43 or 45 and one additional chemistry or physics course.

(2) GES 1C not offered in 2014-15

ENGINEERING FUNDAMENTALS (THREE COURSES MINIMUM, INCLUDING THE TWO LISTED BELOW):

Course	Title	Units	Qtr
ENGR 14	Introduction to Solid Mechanics	4	A, W, S
ENGR 90	Environmental Science and Technology (same as CEE 70)	3	A
	Fundamentals Elective	3-5	

TECHNOLOGY IN SOCIETY (TIS): (One 3-5 unit course required; see Chap 3, Fig 3-3, CEE list)

CIVIL ENGINEERING DEPTH: (Fundamentals + Depth = 68 Units Minimum) At least 68 units of Fundamental and Depth courses are required by ABET and by the Department.

REQUIRED DEPTH CORE: (19 UNITS)

Course	Title	Units	Qtr
CEE100*	Managing Sustainable Building Projects	4	A
CEE101A	Mechanics of Materials	4	W
CEE101B	Mechanics of Fluids	4	S
CEE101C	Geotechnical Engineering (including lab)	4	A
CEE146A	Engineering Economy (or ENGR 60, offered Summer only)	3	W

*CEE 100 meets the Writing in the Major (WIM) requirement.

Specialty Courses

Students choose a specialty in either (1) Structures and Construction or (2) Environmental and Water Studies; each is described below.

CE WITH SPECIALTY IN STRUCTURES AND CONSTRUCTION

The structures and construction track provides students with courses in structural analysis and design, construction, building systems, and other courses related to structural engineering and construction management. A specific requirement of an ABET-accredited Civil Engineering major is participation in a major engineering design experience, which is fulfilled by taking CEE183 (and its prerequisites).

REQUIRED SPECIALTY COURSES: (27 UNITS)

Course	Title	Units	Qtr
ENGR 50 or ENGR 50E or ENGR 50M ⁺	Introduction to Materials Science, Nanotechnology Emphasis	4	S
	Introduction to Materials Science, Energy Emphasis	4	W
	Introduction to Materials Science, Biomaterials Emphasis	4	A
CEE 102	Legal Aspects of Engineering and Construction	3	W
CEE 156	Building Systems Design	4	W
CEE 180 ⁺⁺	Structural Analysis	4	A
CEE 181	Design of Steel Structures	4	A
CEE 182	Design of Reinforced Concrete Structures	4	W
CEE 183	Integrated Civil Engineering Design Project	4	S

+ Any of the E50 series may count as the Engineering Fundamental elective instead, if desired.

++ CEE 180 is a prerequisite to or corequisite for CEE 181, CEE 182, and CEE 183.

SPECIALTY ELECTIVE COURSES: AT LEAST 12 ADDITIONAL UNITS FROM THIS LIST

Course	Title	Units	Qtr
ENGR 15	Dynamics	3	A,S
CME 104*	Linear Algebra and Partial Differential Equations for Engineers	5	S
CEE 101D*	Computations in CEE	3	A
CEE 112A	Industry Applications of Virtual Design and Construction (VDC)	2-4	W
CEE 112B	Advanced Industry Applications of VDC	2-4	S
CEE 120A, 120B, 130, or 134B (only one can apply as a Specialty Elective)		2-4	
CEE 122A/B	Computer Integrated Architecture/Engineering/Construction	2	W,S
CEE 129	Climate Change Adaptation for Seaports	3	A,W,S
CEE 131A	Professional Practice: Mixed-Use Design in an Urban Setting	3	S
CEE 141A	Infrastructure Projects Development	3	A
CEE 141B	Infrastructure Projects Delivery	3	W
CEE 142A	Negotiating Sustainable Development	3	W
CEE 151	Negotiation	3	A,S
CEE 155	Introduction to Sensing Networks for CEE	4	W
CEE 160	Mechanics of Fluids Laboratory	2	S
CEE 161A	Rivers, Streams, and Canals	3-4	A, Sum
CEE 171	Environmental Planning Methods	3	W
CEE 176A	Energy Efficient Buildings	3-4	W
CEE 176B	Electric Power: Renewables and Efficiency	3-4	S
CEE 195A/B	Fundamentals of Structural Geology	3/3	A/W
CEE 196	Engineering Geology Practice (alt. years)	3	S
CEE 199	Undergrad. Research in Civil and Environmental Engineering	1-4	any
CEE 203*	Probabilistic Models in Civil Engineering	3-4	A

* Can count either towards the Math requirement, or as specialty elective course units.

OTHER ELECTIVE COURSES:

Students may choose additional courses from within the School of Engineering to reach a total of 68 units of Fundamentals + Depth courses combined if necessary in order to satisfy ABET and departmental requirements to graduate. The following CEE courses do not satisfy the ABET requirements: CEE 44Q and CEE 133F. For other CEE courses not listed above and for courses outside of CEE, you must obtain approval from the CEE Department Associate Chair to confirm satisfaction of ABET requirements.

CE WITH SPECIALTY IN ENVIRONMENTAL AND WATER STUDIES

The environmental and water studies option focuses on environmental engineering and science, water resources, and environmental planning. ABET-requires that CE majors participate in a major engineering design experience. This is fulfilled by taking CEE169 or CEE179C.

REQUIRED SPECIALTY COURSES: (36 UNITS)

Course	Title	Units	Qtr
ENGR 30+	Engineering Thermodynamics	3	A,W
CEE 101D*	Computations in Civil and Environmental Engineering	3	A
CEE 160	Mechanics of Fluids Laboratory	2	S

CEE 161A	Rivers, Streams and Canals	4	A
CEE 166A	Watersheds and Wetlands	3	A
CEE 166B	Floods and Droughts, Dams and Aqueducts	3	W
CEE 171	Environmental Planning Methods	3	W
CEE 172	Air Quality Management	3	W
CEE 177	Aquatic Chemistry and Biology	4	A
CEE 179A	Water Chemistry Laboratory	3	W
Design Experience: <i>Choose CEE169 or CEE 179C.</i>		5	S

+ Can count as a required Engineering Fundamental instead, if desired.

* Can count either towards the Math requirement, or as required specialty course units.

SPECIALTY ELECTIVE COURSES: AT LEAST 6 ADDITIONAL UNITS FROM THIS LIST

Course	Title	Units	Qtr
CEE 63*	Weather and Storms	3	A
CEE 64*	Air Pollution and Global Warming: History, Science, & Solutions	3	W
CEE 109	Creating a Green Student Workforce to Help Implement Sustainability	2	W
CEE 129	Climate Change Adaptation for Seaports	3	A,W, S
CEE 155	Introduction to Sensing Networks for CEE	4	W
CEE 164	Introduction to Physical Oceanography	4	W
CEE 166D	Water Resources and Water Hazards Field Trips	2	W
CEE 172A	Indoor Air Quality (alt. years)	2-3	S
CEE 173A	Energy Resources	4-5	A
CEE 174A	Providing Safe Water for the Developing and Developed World	3	A
CEE 174B	Wastewater Treatment: from Disposal to Resource Recovery	3	W
CEE 176A	Energy Efficient Buildings	3-4	W
CEE 176B	Electric Power: Renewables and Efficiency	3-4	S
CEE 178	Introduction to Human Exposure Analysis	3	S,Sum
CEE 199	Undergraduate Research in Civil and Environmental Engineering	1-4	any

* Can count either towards the Science requirement, or as specialty elective course units.

Other Elective Courses:

Students may choose additional courses from within the School of Engineering to reach a total of 68 units of Engineering Fundamentals + Depth courses combined if necessary in order to satisfy ABET and departmental requirements to graduate. The following CEE courses do not satisfy the ABET requirements: CEE 44Q and CEE 133F. For other CEE courses not listed above and for courses outside of CEE, you must obtain approval from the CEE Department Associate Chair to confirm satisfaction of ABET requirements.

Civil Engineering

Typical Sequence of Courses

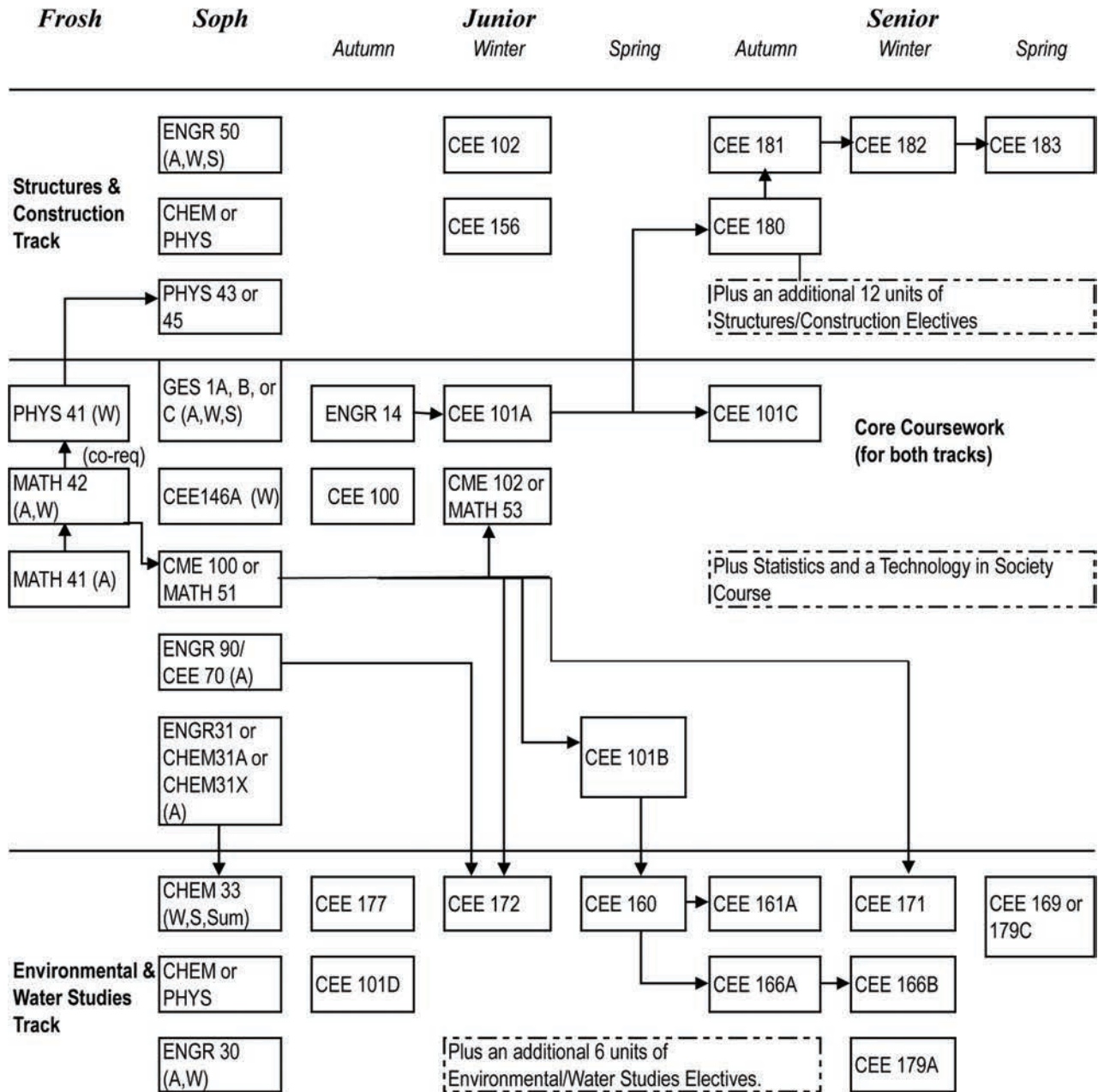

* Arrows represent direct prerequisites or co-requisites; refer to Explore Courses for details

* Dashed-line boxes enclose alternates. These may indicate alternate years in which to take a given course, and/or alternate courses that may be taken at a given time.

Civil Engineering

Structures/Construction (Dry) Track, Regular Program

	<i>Fall</i>				<i>Winter</i>				<i>Spring</i>			
	Math/ Sci.	Engr	Other		Math/ Sci.	Engr	Other		Math/ Sci.	Engr	Other	
<i>Freshman</i>	Class				Class				Class			
	MATH 19	3	-	-	MATH 20	3	-	-	MATH 21	4	-	-
	Unrstr Elctv #	-	-	3	WAYS ++	-	-	3	WAYS ++	-	-	4
	WAYS ++	-	-	3	WAYS ++	-	-	4	Engr Elctv #	-	3	
	PWR1	-	-	4	Unrstr Elctv #	-	-	3	THINK	-	-	4
	<i>Subtotals</i>	<i>3</i>	<i>0</i>	<i>10</i>	<i>Subtotals</i>	<i>3</i>	<i>0</i>	<i>10</i>	<i>Subtotals</i>	<i>4</i>	<i>3</i>	<i>8</i>
	Total			13	Total			13	Total			15
<i>Sophomore</i>	Language	-	-	5	Language	-	-	5	Language	-	-	5
	MATH 51 ^{^^}	5	-	-	PHYSICS 41	4	-	-	PHYSICS 43+	4	-	-
	WAYS ++	-	-	3	MATH 53 ^{^^}	5	-	-	ENGR 14	-	4	
	PWR2	-	-	4	Unrstr Elctv #	-	-	3	ENGR 50	-	4	-
	<i>Subtotals</i>	<i>5</i>	<i>0</i>	<i>12</i>	<i>Subtotals</i>	<i>9</i>	<i>0</i>	<i>8</i>	<i>Subtotals</i>	<i>4</i>	<i>8</i>	<i>5</i>
	Total			17	Total			17	Total			17
<i>Junior</i>	CEE100	-	4	-	CEE 101A	-	4	-	CEE 101B	-	4	-
	CHEM 31A/X	5	-	-	CEE146A	-	3	-	GES 1A/B/C	4	-	-
	CE/Dry Elctv	-	3	-	CEE 102	-	3	-	STAT 60	5	-	-
	ENGR 90/CEE70	-	3	-	CEE 156	-	4	-	CE/Dry Elctv	-	3	-
	<i>Subtotals</i>	<i>5</i>	<i>10</i>	<i>0</i>	<i>Subtotals</i>	<i>0</i>	<i>14</i>	<i>0</i>	<i>Subtotals</i>	<i>9</i>	<i>7</i>	<i>0</i>
	Total			15	Total			14	Total			16
<i>Senior</i>	CEE 101C	-	4	-	CE/Dry Elctv	-	3	-	CE/Dry Elctv	-	3	-
	CEE 180	-	4	-	CEE 182	-	4	-	CEE183	-	4	-
	CEE 181	-	4	-	WAYS ++	-	-	3	Unrstr Elctv	-	-	3
	PHYSICS 45+	4	-	-	TIS Course	-	-	4	WAYS ++	-	-	3
	<i>Subtotals</i>	<i>4</i>	<i>12</i>	<i>0</i>	<i>Subtotals</i>	<i>0</i>	<i>7</i>	<i>7</i>	<i>Subtotals</i>	<i>0</i>	<i>7</i>	<i>6</i>
	Total			16	Total			14	Total			13

Total Math & Science Units: 46

Total Engineering Units: 68

Total Other Units: 66

Total Units: 180

Notes:

- [] Courses in these rows can be rearranged, e.g., to accommodate PWR in any quarter.
- # Students should explore majors of interest to them using these unrestricted electives. Courses in the School of Engineering can count towards the CE major; see description of "Other Elective Courses" for details.
- ^ Enough coursework from within the School of ENGR is needed to total 68 units, including Fundamentals + Depth
- ^^ Can take CME 100 and 102 instead of Math 51 and 53, if desired.
- + Can replace either Phys 43 or Phys 45 with a second chemistry class.
- ++ May need 7 WAYS courses outside of major requirements: 2 in Aesthetic/Interpretive Inquiry, 2 in Social Inquiry, 1 in Ethical Reasoning, 1 in Engaging Diversity, and 1 in Creative Expression.

Civil Engineering

Environmental (Wet) Track, Early Start Program

	<i>Fall</i>			<i>Winter</i>			<i>Spring</i>					
	Math/ Sci.	Engr	Other	Class	Math/ Sci.	Engr	Other	Class	Math/ Sci.	Engr	Other	
<i>Freshman</i>	MATH 41	5	-	-	MATH 42	5	-	-	WAYS ++	-	-	3
					WAYS ++	-	-	3	Unrstr Elctv #	-	-	4
	CHEM 31A+	5	-	-	CHEM 31B+	5	-	-	CHEM 33	5	-	-
	Unrstr Elctv #	-	-	4	PWR1	-	-	4	THINK	-	-	4
	Subtotals	10	0	4	Subtotals	10	0	7	Subtotals	5	0	11
Total	14			Total	17			Total	16			
<i>Sophomore</i>	Language	-	-	5	Language	-	-	5	Language	-	-	5
	CME 100 ^{^^}	5	-	-	CME 102 ^{^^}	5	-	-	GES 1A/B/C	4	-	-
	ENGR90/CEE70*	-	3	-	PHYSICS 41	4	-	-	STAT 60	5	-	-
	Unrstr Elctv #	-	-	3	PWR2	-	-	4	ENGR 14	-	4	-
	Subtotals	5	3	8	Subtotals	9	0	9	Subtotals	9	4	5
Total	16			Total	18			Total	18			
<i>Junior</i>	CEE 177	-	4	-	CEE 146A	-	3	-	CEE 101B	-	4	-
	CEE 100	-	4	-	CEE 101A	-	4	-	CEE 160	-	2	-
	CEE 101D	-	3	-	CEE 172*	-	3	-	WAYS ++	-	-	4
	ENGR 30*	-	4	-	CE/Wet Elctv	-	3	-	TIS Class	-	-	4
	Subtotals	0	15	0	Subtotals	0	13	0	Subtotals	0	6	8
Total	15			Total	13			Total	14			
<i>Senior</i>	CEE166A	-	3	-	CEE166B	-	3	-	CEE 169**	-	5	-
	CEE161A	-	4	-	CEE 171	-	3	-	WAYS ++	-	-	3
	CEE101C	-	4	-	CEE 179A	-	3	-	WAYS ++	-	-	3
	WAYS ++	-	-	3	WAYS ++	-	-	3	CE/Wet Elctv	-	3	-
	Subtotals	0	11	3	Subtotals	0	9	3	Subtotals	0	8	6
Total	14			Total	12			Total	14			

Total Math & Science Units: 48
 Total Engineering Units: 69
 Total Other Units: 64
Total Units: 181

Notes:

-] Courses in this row can be rearranged, eg, to accommodate PWR in any quarter.
- # Students should explore majors of interest to them using these unrestricted electives. Courses in the School of Engineering can count towards the CE major; see description of "Other Elective Courses" for details.
- ^ Enough coursework from within the School of Engineering is needed to total 68 units, including Fundamentals + Depth
- ^^ Can take Math 51 and 53 instead of CME 100 and 102, if desired.
- + If Chem 31X or Engr 31 is substituted for Chem 31A, then replace Chem 31B with another chem or physics class.
- ++ May need 7 WAYS courses outside of major reqmts: 2 in Aesthetic/Interpretive Inquiry, 2 in Social Inquiry, 1 in Ethical Reasoning, 1 in Engaging Diversity, and 1 in Creative Expression.
- * These Aut/Win classes all are typically offered MWF10.
- ** In alternate years, when CEE169 is not offered, take CEE179C in spring to fulfill the capstone design experience.

Civil Engineering

Environmental (Wet) Track, Regular Program

	<i>Fall</i>			<i>Winter</i>			<i>Spring</i>					
	Math/ Sci.	Engr	Other	Class	Math/ Sci.	Engr	Other	Class	Math/ Sci.	Engr	Other	
<i>Freshman</i>	MATH 19	3	-	-	MATH 20	3	-	-	MATH 21	4	-	-
	Unrstr Elctv #	-	-	3	WAYS ++	-	-	3	WAYS ++	-	-	3
	WAYS ++	-	-	3	WAYS ++	-	-	4	Unrstr Elctv #	-	-	4
	THINK	-	-	4	Unrstr Elctv #	-	-	4	PWR1	-	-	4
	<i>Subtotals</i>	3	0	10	<i>Subtotals</i>	3	0	11	<i>Subtotals</i>	4	0	11
Total	13			Total	14			Total	15			
<i>Sophomore</i>	Language	-	-	5	Language	-	-	5	Language	-	-	5
	CHEM 31A+	5	-	-	CHEM 31B+	5	-	-	CHEM 33	5	-	-
	MATH 51 ^{^^}	5	-	-	PHYSICS 41	4	-	-	WAYS ++	-	-	3
	ENGR90/CEE70*	-	3	-	WAYS ++	-	-	3	PWR2	-	-	4
	<i>Subtotals</i>	10	3	5	<i>Subtotals</i>	9	0	8	<i>Subtotals</i>	5	0	12
Total	18			Total	17			Total	17			
<i>Junior</i>	ENGR 14	-	4	-	CEE101A	-	4	-	CEE 101B	-	4	-
	CEE 100	-	4	-	CEE 171	-	3	-	CEE 160	-	2	-
	CEE 101D	-	3	-	CEE146A	-	3	-	STAT 60	5	-	-
	MATH 53 ^{^^}	5	-	-	ENGR 30*	-	3	-	CE/Wet Elctv	-	3	-
	<i>Subtotals</i>	5	11	0	<i>Subtotals</i>	0	13	0	<i>Subtotals</i>	5	9	0
Total	16			Total	13			Total	14			
<i>Senior</i>	CEE101C	-	4	-	CEE 172*	-	3	-	CEE 169**	-	5	-
	CEE 161A	-	4	-	CEE 179A	-	3	-	GES 1A/B/C	4	-	-
	CEE 166A	-	3	-	CEE 166B	-	3	-	WAYS ++	-	-	3
	CEE 177	-	4	-	TIS Course	-	-	4	CE/Wet Elctv	-	3	-
	<i>Subtotals</i>	0	15	0	<i>Subtotals</i>	0	9	4	<i>Subtotals</i>	4	8	3
Total	15			Total	13			Total	15			

Total Math & Science Units: 48

Total Engineering Units: 68

Total Other Units: 64

Total Units: 180

Notes:

----- Courses in this row can be rearranged, e.g., to accommodate PWR in any quarter.

Students should explore majors of interest to them using these unrestricted electives. Courses in the School of Engineering can count towards the CE major; see description of "Other Elective Courses" for details.

^ Enough coursework from within the School of ENGR is needed to total 68 units, including Fundamentals + Depth

^^ Can take CME 100 and 102 instead of Math 51 and 53, if desired.

+ If Chem 31X or Engr 31 is substituted for Chem 31A, then replace Chem 31B with another chem or physics class.

++ May need 7 WAYS courses outside of major requirements: 2 in Aesthetic/Interpretive Inquiry, 2 in Social Inquiry, 1 in Ethical Reasoning, 1 in Engaging Diversity, and 1 in Creative Expression.

* These Aut/Win classes all are typically offered MWF10.

** In alternate years, when CEE169 is not offered, take CEE179C in spring to fulfill the capstone design experience.

Civil Engineering

Structures/Construction (Dry) Track, Early Start Program

	<i>Fall</i>			<i>Winter</i>				<i>Spring</i>				
	Math/			Math/				Math/				
	Class	Sci.	Engr	Other	Class	Sci.	Engr	Other	Class	Sci.	Engr	Other
<i>Freshman</i>	MATH 41	5	-	-	MATH 42	5	-	-	STAT 60	5	-	-
		-	-		Unrstr Elctv #	-	-	3	ENGR 14	-	4	-
	CHEM 31A/X	5			PHYSICS 41	4	-	-	PHYSICS 43+	4	-	-
	Unrstr Elctv #	-	-	4	THINK	-		4	PWR1	-	-	4
	<i>Subtotals</i>	10	0	4	<i>Subtotals</i>	9	0	7	<i>Subtotals</i>	9	4	4
	Total	14			Total	16			Total	17		
<i>Sophomore</i>	Language	-	-	5	Language	-	-	5	Language	-	-	5
	CME 100 ^{^^}	5	-	-	CME 102 ^{^^}	5	-	-	Engr Elctv [^]	-	3	-
	PHYSICS 45+	4	-	-	CEE 156	-	4	-	ENGR 50	-	4	-
	Unrstr Elctv #	-	-	3	WAYS ++	-	-	3	PWR2	-	-	4
	<i>Subtotals</i>	9	0	8	<i>Subtotals</i>	5	4	8	<i>Subtotals</i>	0	7	9
	Total	17			Total	17			Total	16		
<i>Junior</i>	GES 1A/B/C	4	-	-	CEE 101A	-	4	-	CEE 101B	-	4	-
	CEE 100	-	4	-	CEE 102	-	3	-	CE/Dry Elctv	-	3	-
	ENGR 90/CEE70	-	3	-	CEE146A	-	3	-	WAYS ++	-	-	3
	WAYS ++	-	-	4	CE/Dry Elctv	-	3	-	Unrstr Elctv	-	-	3
	<i>Subtotals</i>	4	7	4	<i>Subtotals</i>	0	13	0	<i>Subtotals</i>	0	7	6
	Total	15			Total	13			Total	13		
<i>Senior</i>	CEE 101C	-	4	-	CE/Dry Elctv	-	3	-	WAYS ++	-	-	3
	CEE 180	-	4	-	CEE 182	-	4	-	CEE183	-	4	-
	CEE 181	-	4	-	WAYS ++	-	-	3	WAYS ++	-	-	3
	WAYS ++	-	-	3	TiS Course	-	-	4	CE/Dry Elctv	-	3	-
	<i>Subtotals</i>	0	12	3	<i>Subtotals</i>	0	7	7	<i>Subtotals</i>	0	7	6
	Total	15			Total	14			Total	13		

Total Math & Science Units: 46
 Total Engineering Units: 68
 Total Other Units: 66
Total Units: 180

Notes:

- - - Courses in these rows can be rearranged, e.g., to accommodate PWR in any quarter.
- # Students should explore majors of interest to them using these unrestricted electives. Courses in the School of Engineering can count towards the CE major; see description of "Other Elective Courses" for details.
- ^ Enough coursework from within the School of ENGR is needed to total 68 units, including Fundamentals + Depth
- ^^ Can take Math 51 and 53 instead of CME 100 and 102, if desired.
- + Can replace either Phys 43 or Phys 45 with a second chemistry class.
- ++ May need 7 WAYS courses outside of major requirements: 2 in Aesthetic/Interpretive Inquiry, 2 in Social Inquiry, 1 in Ethical Reasoning, 1 in Engaging Diversity, and 1 in Creative Expression.

Civil Engineering

Structures/Construction (Dry) Track, Autumn Quarter Junior Year Abroad

	Fall				Winter				Spring			
	Class	Math/ Sci.	Engr	Other	Class	Math/ Sci.	Engr	Other	Class	Math/ Sci.	Engr	Other
<i>Freshman</i>	MATH 41	5	-	-	MATH 42	5	-	-	MATH 51	5	-	-
	WAYS ^^	-	-	4	WAYS ^^	-	-	3	Unrstr Elctv #	-	-	3
					PHYSICS 41	4	-	-	WAYS ^^	-	-	3
	THINK	-	-	4	Unrstr Elctv #	-	-	3	PWR1	-	-	4
	<i>Subtotals</i>	5	0	8	<i>Subtotals</i>	9	0	6	<i>Subtotals</i>	5	0	10
Total			13	Total			15	Total			15	
<i>Sophomore</i>	Language	-	-	5	Language	-	-	5	Language	-	-	5
	CHEM 31A/X	5	-	-	MATH 53	5	-	-	PHYSICS 43+	4	-	-
	PHYSICS 45+	4	-	-	CEE 146A	-	3	-	Engr Elctv^	-	3	-
	CEE 100	-	4	-	ENGR 14 ++	-	4	-	PWR2	-	-	4
	<i>Subtotals</i>	9	4	5	<i>Subtotals</i>	5	7	5	<i>Subtotals</i>	4	3	9
Total			18	Total			17	Total			16	
<i>Junior</i>	WAYS ^^	-	-	5	CEE 101A	-	4	-	CEE 101B	-	4	-
	WAYS ^^	-	-	4	ENGR 50 ++	-	4	-	CE/Dry Elctv	-	3	-
	Unrstr Elctv	-	-	4	CEE 156	-	4	-	CE/Dry Elctv	-	3	-
	--- Autumn Quarter Abroad --- ++				WAYS ^^	-	-	3	STATS 60	5	-	-
	<i>Subtotals</i>	0	0	13	<i>Subtotals</i>	0	12	3	<i>Subtotals</i>	5	10	0
Total			13	Total			15	Total			15	
<i>Senior</i>	CEE 101C	-	4	-	CEE 102	-	3	-	WAYS ^^	-	-	3
	CEE 180	-	4	-	CEE 182	-	4	-	CEE 183	-	4	-
	CEE 181	-	4	-	TIS Course	-	-	4	CE/Dry Elctv	-	3	-
	ENGR 90/CEE70	-	3	-	CE/Dry Elctv	-	3	-	GES 1A/B/C	4	-	-
	<i>Subtotals</i>	0	15	0	<i>Subtotals</i>	0	10	4	<i>Subtotals</i>	4	7	3
Total			15	Total			14	Total			14	

Total Math & Science Units: 46

Total Engineering Units: 68

Total Other Units: 66

Total Units: 180

Notes:

- Courses in these rows can be rearranged, eg, to accommodate PWR in any quarter.
- # Students should explore majors of interest to them using these unrestricted electives. Courses in the School of Engineering can count towards the CE major; see description of "Other Elective Courses" for details.
- ^ Enough coursework from within the School of Engineering is needed to reach a total of 68 Engineering Units; see description of "Other Elective Courses" for details.
- ^^ Save some WAYS for Overseas program. May need 7 WAYS courses outside of major reqmts: 2 in Aesthetic/ Interpretive Inquiry, 2 in Social Inquiry, 1 in Ethical Reasoning, 1 in Engaging Diversity, and 1 in Creative Expression.
- + Can replace either Phys 43 or Phys 45 with a second chemistry class.
- ++ ENGR 14 must be taken as a sophomore to do Aut quarter overseas. Some Overseas programs offer ENGR 40 or 50.

Civil Engineering

Structures/Construction (Dry) Track, Winter Quarter Junior Year Abroad

	<i>Fall</i>				<i>Winter</i>				<i>Spring</i>			
	Math/ Sci.	Engr	Other		Math/ Sci.	Engr	Other		Math/ Sci.	Engr	Other	
<i>Freshman</i>	Class				Class				Class			
	MATH 41	5	-	-	MATH 42	5	-	-	MATH 51	5	-	-
	WAYS ^^	-	-	4	WAYS ^^	-	-	3	Unrstr Elctv#	-	-	3
					PHYSICS 41	4	-	-	WAYS ^^	-	-	3
	THINK	-	-	4	Unrstr Elctv#	-	-	3	PWR1	-	-	4
	<i>Subtotals</i>	5	0	8	<i>Subtotals</i>	9	0	6	<i>Subtotals</i>	5	0	10
	Total			13	Total			15	Total			15
<i>Sophomore</i>	Language	-	-	5	Language	-	-	5	Language	-	-	5
	ENGR 14 ++	-	4	-	CEE 101A ++	-	4	-	ENGR 50 ++	-	4	-
	PHYSICS 45+	4	-	-	CEE 146A	-	3	-	PHYSICS 43+	4	-	-
	Engr Elctv^	-	3	-	MATH 53	5	-	-	PWR2	-	-	4
	<i>Subtotals</i>	4	7	5	<i>Subtotals</i>	5	7	5	<i>Subtotals</i>	4	4	9
	Total			16	Total			17	Total			17
<i>Junior</i>	STATS 60	5	-	-	WAYS ^^	-	-	5	CEE 101B	-	4	-
	CHEM 31A/X	5	-	-	WAYS ^^	-	-	4	CE/Dry Elctv	-	3	-
	CE/Dry Elctv	-	3	-	Unrstr Elctv	-	-	4	CE/Dry Elctv	-	3	-
	ENGR 90/CEE70	-	3	-	--- Winter Quarter Abroad --- ++				GES 1A/B/C	4	-	-
	<i>Subtotals</i>	10	6	0	<i>Subtotals</i>	0	0	13	<i>Subtotals</i>	4	10	0
	Total			16	Total			13	Total			14
<i>Senior</i>	CEE 101C	-	4	-	CEE 102	-	3	-	CEE183	-	4	-
	CEE 180	-	4	-	CEE 182	-	4	-	WAYS ^^	-	-	3
	CEE 181	-	4	-	CEE 156	-	4	-	WAYS ^^	-	-	3
	CEE 100	-	4	-	TIS Course	-	-	4	CE/Dry Elctv	-	3	-
	<i>Subtotals</i>	0	16	0	<i>Subtotals</i>	0	11	4	<i>Subtotals</i>	0	7	6
	Total			16	Total			15	Total			13

Total Math & Science Units: 46
 Total Engineering Units: 68
 Total Other Units: 66
Total Units: 180

Notes:

- Courses in these rows can be rearranged, eg, to accommodate PWR in any quarter.
- # Students should explore majors of interest to them using these unrestricted electives. Courses in the School of Engineering can count towards the CE major; see description of "Other Elective Courses" for details.
- ^ Enough coursework from within the School of Engineering is needed to reach a total of 68 Engineering Units; see description of "Other Elective Courses" for details.
- ^^ Save some WAYS for Overseas program. May need 7 WAYS courses outside of major reqmts: 2 in Aesthetic/ Interpretive Inquiry, 2 in Social Inquiry, 1 in Ethical Reasoning, 1 in Engaging Diversity, and 1 in Creative Expression.
- + Can replace either Phys 43 or Phys 45 with a second chemistry class.
- ++ ENGR14/CEE101A must be taken Soph Aut/Win to do Win qtr overseas. Some Overseas programs offer ENGR 40 or 50.

Civil Engineering

Structures/Construction (Dry) Track, Spring Quarter Junior Year Abroad

	<i>Fall</i>			<i>Winter</i>				<i>Spring</i>				
	Math/ Sci.	Engr	Other	Class	Math/ Sci.	Engr	Other	Class	Math/ Sci.	Engr	Other	
<i>Freshman</i>	MATH 41	5	-	-	MATH 42	5	-	-	MATH 51	5	-	-
		-	-	-	WAYS ^^	-	-	3	Unrstr Elctv#	-	-	3
	WAYS ^^	-	-	4	PHYSICS 41	4	-	-	WAYS ^^	-	-	3
	THINK	-	-	4	Unrstr Elctv#	-	-	3	PWR1	-	-	4
	<i>Subtotals</i>	5	0	8	<i>Subtotals</i>	9	0	6	<i>Subtotals</i>	5	0	10
Total	13			Total	15			Total	15			
<i>Sophomore</i>	Language	-	-	5	Language	-	-	5	Language	-	-	5
	Engr Elctv #	-	3	-	CEE 146A	-	3	-	CE/Dry Elctv	-	3	-
	CEE 100	-	4	-	MATH 53	5	-	-	PHYSICS 43+	4	-	-
	GES 1A/B/C	4	-	-	WAYS	-	-	3	PWR2	-	-	4
	<i>Subtotals</i>	4	7	5	<i>Subtotals</i>	5	3	8	<i>Subtotals</i>	4	3	9
Total	16			Total	16			Total	16			
<i>Junior</i>	ENGR 14	-	4	-	CEE 101A	-	4	-	WAYS ^^	-	-	5
	CHEM 31A/X	5	-	-	CEE 102	-	3	-	WAYS ^^	-	-	4
	PHYSICS 45+	4	-	-	STATS 60	5	-	-	Unrstr Elctv	-	-	4
	ENGR 90/CEE70	-	3	-	CE/Dry Elctv	-	3	-	--- Spring Quarter Abroad --- ++			
	<i>Subtotals</i>	9	7	0	<i>Subtotals</i>	5	10	0	<i>Subtotals</i>	0	0	13
Total	16			Total	15			Total	13			
<i>Senior</i>	CEE 101C	-	4	-	CEE 182	-	4	-	CEE 101B	-	4	-
	CEE 180	-	4	-	CEE 156	-	4	-	CEE 183	-	4	-
	CEE 181	-	4	-	ENGR 50M ++	-	4	-	CE/Dry Elctv	-	3	-
	CE/Dry Elctv	-	3	-	TIS Course	-	-	4	WAYS ^^	-	-	3
	<i>Subtotals</i>	0	15	0	<i>Subtotals</i>	0	12	4	<i>Subtotals</i>	0	11	3
Total	15			Total	16			Total	14			

Total Math & Science Units: 46

Total Engineering Units: 68

Total Other Units: 66

Total Units: 180

Notes:

--- Courses in these rows can be rearranged, eg, to accommodate PWR in any quarter.

Students should explore majors of interest to them using these unrestricted electives. Courses in the School of Engineering can count towards the CE major; see description of "Other Elective Courses" for details.

^ Enough coursework from within the School of Engineering is needed to reach a total of 68 Engineering Units; see description of "Other Elective Courses" for details.

^^ Save some WAYS for Overseas program. May need 7 WAYS courses outside of major reqmts: 2 in Aesthetic/ Interpretive Inquiry, 2 in Social Inquiry, 1 in Ethical Reasoning, 1 in Engaging Diversity, and 1 in Creative Expression.

+ Can replace either Phys 43 or Phys 45 with a second chemistry class.

++ Some Overseas programs offer ENGR 40 or 50.

Civil Engineering

Environmental (Wet) Track, Autumn Quarter Junior Year Abroad

	<i>Fall</i>			<i>Winter</i>			<i>Spring</i>					
	Math/			Math/			Math/					
	Class	Sci.	Engr	Other	Class	Sci.	Engr	Other	Class	Sci.	Engr	Other
<i>Freshman</i>	MATH 41	5	-	-	MATH 42	5	-	-	MATH 51	5	-	-
	WAYS ^^	-	-	4	WAYS ^^	-	-	3	Unrstr Elctv#	-	-	3
	-----	-----	-----	-----	PHYSICS 41	4	-	-	GES 1A/B/C	4	-	-
	THINK	-	-	4	PWR1	-	-	4	WAYS ^^	-	-	3
	-----	-----	-----	-----	-----	-----	-----	-----	-----	-----	-----	-----
	<i>Subtotals</i>	5	0	8	<i>Subtotals</i>	9	0	7	<i>Subtotals</i>	9	0	6
	Total	13			Total	16			Total	15		
<i>Sophomore</i>	Language	-	-	5	Language	-	-	5	Language	-	-	5
	CHEM 31A+	5	-	-	CHEM 31B+	5	-	-	CHEM 33	5	-	-
	ENGR90/CEE70*++	-	3	-	STATS 60	5	-	-	ENGR 14 ++	-	4	-
	CEE 100 ++	-	4	-	PWR2	-	-	4	MATH 53	5	-	-
	-----	-----	-----	-----	-----	-----	-----	-----	-----	-----	-----	-----
	<i>Subtotals</i>	5	7	5	<i>Subtotals</i>	10	0	9	<i>Subtotals</i>	10	4	5
	Total	17			Total	19			Total	19		
<i>Junior</i>	WAYS ^^	-	-	5	CEE 101A	-	4	-	CEE 101B	-	4	-
	WAYS ^^	-	-	4	ENGR 30*	-	3	-	CEE 160	-	2	-
	Unrstr Elctv	-	-	4	CEE 146A	-	3	-	CE/Wet Elctv	-	3	-
	--- Autumn Quarter Abroad --- ++	-	-	-	CE/Wet Elctv	-	3	-	WAYS ^^	-	-	4
	-----	-----	-----	-----	-----	-----	-----	-----	-----	-----	-----	-----
	<i>Subtotals</i>	0	0	13	<i>Subtotals</i>	0	13	0	<i>Subtotals</i>	0	9	4
	Total	13			Total	13			Total	13		
<i>Senior</i>	CEE 101C	-	4	-	CEE 166B	-	3	-	CEE 169**	-	5	-
	CEE 161A	-	4	-	CEE 171	-	3	-	TIS Course	-	-	4
	CEE 166A	-	3	-	CEE 179A	-	3	-	WAYS ^^	-	-	3
	CEE 177	-	4	-	CEE 172*	-	3	-				
	CEE 101D	-	3	-								
	-----	-----	-----	-----	-----	-----	-----	-----	-----	-----	-----	-----
		<i>Subtotals</i>	0	18	0	<i>Subtotals</i>	0	12	0	<i>Subtotals</i>	0	5
	Total	18			Total	12			Total	12		

Total Math & Science Units: 48

Total Engineering Units: 68

Total Other Units: 64

Total Units: 180

Notes:

----- Courses in this row can be rearranged, eg, to accommodate PWR in more than one quarter.

Students should explore majors of interest to them using these unrestricted electives. Courses in the School of Engineering can count towards the CE major; see description of "Other Elective Courses" for details.

^ Enough coursework from within the School of Engineering is needed to reach a total of 68 Engineering Units; see description of "Other Elective Courses" for details.

^^ Save some WAYS for Overseas program. May need 7 WAYS courses outside of major reqmts: 2 in Aesthetic/ Interpretive Inquiry, 2 in Social Inquiry, 1 in Ethical Reasoning, 1 in Engaging Diversity, and 1 in Creative Expression.

+ If Chem 31X or ENGR 31 is substituted for Chem 31A, then replace Chem 31B with another chem or physics class.

++ ENGR 14 must be taken in sophomore year to do Autumn quarter overseas. ENGR 90 and CEE 100 must be taken in Autumn of sophomore year, to minimize overcrowding in Autumn of senior year.

** In alternate years, when CEE 169 is not offered, take CEE 179C in the spring to fulfill design experience.

Civil Engineering

Environmental (Wet) Track, Winter Quarter Junior Year Abroad

	<i>Fall</i>			<i>Winter</i>			<i>Spring</i>					
	Math/ Sci.	Engr	Other	Class	Math/ Sci.	Engr	Other	Class	Math/ Sci.	Engr	Other	
<i>Freshman</i>	MATH 41	5	-	-	MATH 42	5	-	-	MATH 51	5	-	-
	WAYS ^^	-	-	4	Unrstr Elctv #	-	-	3	WAYS ^^	-	-	4
					PHYSICS 41	4	-	-	WAYS ^^	-	-	3
	THINK	-	-	4	WAYS ^^	-	-	3	PWR1	-	-	4
	<i>Subtotals</i>	<i>5</i>	<i>0</i>	<i>8</i>	<i>Subtotals</i>	<i>9</i>	<i>0</i>	<i>6</i>	<i>Subtotals</i>	<i>5</i>	<i>0</i>	<i>11</i>
Total	13			Total	15			Total	16			
<i>Sophomore</i>	Language	-	-	5	Language	-	-	5	Language	-	-	5
	CHEM 31A	5	-	-	CHEM 31B	5	-	-	CHEM 33	5	-	-
	ENGR 14 ++	-	4	-	CEE101A ++	-	4	-	MATH 53	5	-	-
	ENGR 90/CEE70*	-	3	-	CEE146A ++	-	3	-	PWR2	-	-	4
	<i>Subtotals</i>	<i>5</i>	<i>7</i>	<i>5</i>	<i>Subtotals</i>	<i>5</i>	<i>7</i>	<i>5</i>	<i>Subtotals</i>	<i>10</i>	<i>0</i>	<i>9</i>
Total	17			Total	17			Total	19			
<i>Junior</i>	CEE 100	-	4	-	WAYS ^^	-	-	5	CEE 101B	-	4	-
	CEE 177	-	4	-	WAYS ^^	-	-	4	CEE 160	-	2	-
	ENGR 30*	-	3	-	Unrstr Elctv	-	-	4	STAT 60	5	-	-
	CEE 101D	-	3	-	--- Winter Quarter Abroad --- ++				GES 1A/B/C	4	-	-
	<i>Subtotals</i>	<i>0</i>	<i>14</i>	<i>0</i>	<i>Subtotals</i>	<i>0</i>	<i>0</i>	<i>13</i>	<i>Subtotals</i>	<i>9</i>	<i>6</i>	<i>0</i>
Total	14			Total	13			Total	15			
<i>Senior</i>	CE/Wet Elctv	-	3	-	CEE 171	-	3	-	CEE 169**	-	5	-
	CEE101C	-	4	-	CEE 172*	-	3	-	CE/Wet Elctv	-	3	-
	CEE 161A	-	4	-	CEE 179A	-	3	-	TIS Course	-	-	4
	CEE 166A	-	3	-	CEE 166B	-	3	-	WAYS ^^	-	-	3
	<i>Subtotals</i>	<i>0</i>	<i>14</i>	<i>0</i>	<i>Subtotals</i>	<i>0</i>	<i>12</i>	<i>0</i>	<i>Subtotals</i>	<i>0</i>	<i>8</i>	<i>7</i>
Total	14			Total	12			Total	15			

Total Math & Science Units: 48

Total Engineering Units: 68

Total Other Units: 64

Total Units: 180

Notes:

[- - - -] Courses in this row can be rearranged, eg, to accommodate PWR1 in more than one quarter.

Students should explore majors of interest to them using these unrestricted electives. Courses in the School of Engineering can count towards the CE major; see description of "Other Elective Courses" for details.

^ Enough coursework from within the School of Engineering is needed to reach a total of 68 Engineering Units; see description of "Other Elective Courses" for details.

^^ Save some WAYS for Overseas program. May need 7 WAYS courses outside of major reqmts: 2 in Aesthetic/ Interpretive Inquiry, 2 in Social Inquiry, 1 in Ethical Reasoning, 1 in Engaging Diversity, and 1 in Creative Expression.

+ If Chem 31X or ENGR 31 is substituted for Chem 31A, then replace Chem 31B with another chem or physics class.

++ The sequence of ENGR 14 and CEE 101A must be taken by Aut/Win of Soph Yr to do Win qtr overseas as a Junior. Also, should take CEE146A (or CEE171 or 172) in Win of Soph Yr, to keep Win qtr of Sr year from being too crowded.

* These Aut/Win classes all are typically offered MWF10.

** In alternate years, when CEE 169 is not offered, take CEE 179B or C in the spring to fulfill design experience.

Civil Engineering

Environmental (Wet) Track, Spring Quarter Junior Year Abroad

	<i>Fall</i>			<i>Winter</i>			<i>Spring</i>					
	Math/ Sci.	Engr	Other	Class	Math/ Sci.	Engr	Other	Class	Math/ Sci.	Engr	Other	
<i>Freshman</i>	MATH 41	5	-	-	MATH 42	5	-	-	MATH 51	5	-	-
		-	-	-	WAYS ^^	-	-	3	WAYS ^^	-	-	3
	WAYS ^^	-	-	4	PHYSICS 41	4	-	-	Unrstr Elctv #	-	-	4
	THINK	-	-	4	WAYS ^^	-	-	3	PWR1	-	-	4
	<i>Subtotals</i>	5	0	8	<i>Subtotals</i>	9	0	6	<i>Subtotals</i>	5	0	11
Total			13	Total			15	Total			16	
<i>Sophomore</i>	Language	-	-	5	Language	-	-	5	Language	-	-	5
	CHEM 31A+	5	-	-	CHEM 31B+	5	-	-	CEE 101B++	-	4	-
	ENGR 90/CEE70*	-	3	-	CEE146A	-	3	-	CEE 160++	-	2	-
	ENGR 14	-	4	-	MATH 53	5	-	-	PWR2	-	-	4
	<i>Subtotals</i>	5	7	5	<i>Subtotals</i>	10	3	5	<i>Subtotals</i>	0	6	9
Total			17	Total			18	Total			15	
<i>Junior</i>	CEE 100	-	4	-	CEE 101A	-	4	-	WAYS ^^	-	-	5
	CEE 177	-	4	-	CEE 171	-	3	-	WAYS ^^	-	-	4
	CEE 101D	-	3	-	CHEM 33	5	-	-	Unrstr Elctv	-	-	4
	CE/Wet Elctv	-	3	-	ENGR 30*	-	3	-	--- Spring Quarter Abroad ---	++		
	<i>Subtotals</i>	0	14	0	<i>Subtotals</i>	5	10	0	<i>Subtotals</i>	0	0	13
Total			14	Total			15	Total			13	
<i>Senior</i>	CEE101C	-	4	-	CEE 166B	-	3	-	CEE 169**	-	5	-
	CEE 161A	-	4	-	CEE 172*	-	3	-	CE/Wet Elctv	-	3	-
	CEE 166A	-	3	-	CEE 179A	-	3	-	WAYS ^^	-	-	3
	STAT 60	5	-	-	TIS Course	-	-	4	GES 1A/B/C	4	-	-
	<i>Subtotals</i>	5	11	0	<i>Subtotals</i>	0	9	4	<i>Subtotals</i>	4	8	3
Total			16	Total			13	Total			15	

Total Math & Science Units: 48

Total Engineering Units: 68

Total Other Units: 64

Total Units: 180

Notes:

- Courses in this row can be rearranged, eg, to accommodate PWR in more than one quarter.
- # Students should explore majors of interest to them using these unrestricted electives. Courses in the School of Engineering can count towards the CE major; see description of "Other Elective Courses" for details.
- ^ Enough coursework from within the School of Engineering is needed to reach a total of 68 Engineering Units; see description of "Other Elective Courses" for details.
- ^^ Save some WAYS for Overseas program. May need 7 WAYS courses outside of major reqmts: 2 in Aesthetic/ Interpretive Inquiry, 2 in Social Inquiry, 1 in Ethical Reasoning, 1 in Engaging Diversity, and 1 in Creative Expression.
- + If Chem 31X or ENGR 31 is substituted for Chem 31A, then replace Chem 31B with another chem or physics class.
- ++ CEE 101B and CEE 160 must be taken Soph year, Spr qtr, to do Spring quarter overseas as a Junior.
- * These Aut/Win classes all are typically offered MWF10.
- ** In alternate years, when CEE 169 is not offered, take CEE 179B or C in the spring to fulfill design experience.

Instructions for Declaring a Major in Civil Engineering

1. Enter your major declaration as Civil Engineering in Axess
2. Print out your Stanford transcript (unofficial is fine) from Axess.
3. Download and complete your major Program Sheet, which you can obtain from the UGHB website. Be sure to fill in all courses that you have taken and those that you plan to take. You will have the opportunity to revise your Program Sheet later, so please fill in as many courses as you can.
4. Bring your transcript and completed program sheet to Jill Filice in the CEE Student Services office in Room 316 of the Jerry Yang and Akiko Yamazaki Environment & Energy (Y2E2) Building and request to have a CEE advisor assigned to you. You may request a specific advisor if you wish. Office hours are 10:00 am to noon and 2:00 to 4:00 pm, Monday through Friday.
5. Meet with your CEE undergraduate advisor to review and sign your program sheet.
6. Return your signed program sheet to the CEE Student Services Specialist, who upon receiving your signed sheet will approve your major declaration in Axess.
7. You are encouraged to meet with your CEE undergraduate adviser at least once a quarter to review your academic progress. Changes to your program sheet can be made by printing out a revised sheet, obtaining your undergraduate adviser's signature, and returning the approved sheet to the CEE Student Services Office.
NOTE –Be sure to confirm that your program sheet is up to date at least one quarter prior to graduation.
8. Other Information:
 - Procedures for requesting transfer credits and program deviations are described in detail at the beginning of Chapter 4: "Policies and Procedures" of this handbook. The relevant forms are in the back of this handbook in the "Forms" section, or on the UGHB site under the "Petitions" link. The online forms may be filled out electronically. If you are requesting transfer credits or program deviations, you should bring your completed petition form with your transcript to the CEE Student Services office. Attach your program sheet on file in CEE.
 - Check with the CEE Student Services Office to make sure that you are on the CEE undergraduate student email list for important announcements.

Note: The online version of your major (link from the Home or Major Programs page of the UGHB website) is considered the definitive version of 2014-15 requirements; corrections or updates may have been made after the printed and pdf versions were published in August 2014.

★ You must use a program sheet from a year you have been enrolled at Stanford.

Civil Engineering Program Sheet – Structures & Construction Track (continued)

Engineering Topics (Fundamentals + Depth combined must equal 68 units. See note 3)

Dept	Course	Title	Transfer/AP Approval by SoE			Units	Grade
			✓ if Transfer	SoE Initials	Date		
<i>Engineering Fundamentals (3 courses required)</i>							
ENGR	14	Introduction to Solid Mechanics (req'd)				4	
ENGR	90	Environmental Science & Technology (req'd) (crosslisted with CEE 70)				3	
ENGR		(ENGR 50/50E/50M, or other ENGR Fundamental)					
<i>Engineering Fundamentals Unit Total</i>							

Engineering Depth

CEE	146A	(or ENGR 60) Engineering Economy (req'd)				3	
CEE	100	Managing Sustainable Building Projects (req'd) WIM				4	
CEE	101A	Mechanics of Materials (req'd)				4	
CEE	101B	Mechanics of Fluids (req'd)				4	
CEE	101C	Geotechnical Engineering (req'd)				4	
CEE	102	Legal Aspects of Engineering and Construction (req'd)				3	
CEE	156	Building Systems (req'd)				4	
CEE	180	Structural Analysis (req'd)				4	
CEE	181	Design of Steel Structures (req'd)				4	
CEE	182	Design of Reinforced Concrete Structures (req'd)				4	
CEE	183	Integrated Civil Engineering Design Project (req'd)				4	
CEE		1st Specialty elective course (2-5 units)					
CEE		2nd Specialty elective course (2-5 units)					
CEE		3rd Specialty elective course (2-5 units)					
CEE		4th Specialty elective course (if needed; must have 12 units of specialty electives)					
ENGR	50/50E/M	(req'd; list here only if not listed above under Fundamentals)					
		Add ENGR Elective(s), if needed, to reach 68 units approved Fund + Depth (note 3)					
<i>Engineering Depth Unit Total</i>							

Program Totals (ABET Requirements)

Mathematics and Science (45 units minimum)

Engineering Topics (Fundamentals + Depth) (68 units minimum)

Program Approvals

Advisor

Printed Name: _____

Date: _____

Signature: _____

Departmental

Printed Name: _____

Date: _____

Signature: _____

School of Engineering (No action required-office use only)

Printed Name: _____

Date: _____

Signature: _____

NOTES (continued from page 1)

- (3) In order to satisfy ABET requirements for graduation, the CEE major must take enough courses so that the combined Engineering units from Fundamentals and Depth courses add up to a minimum of 68 units.

Stanford University ♦ School of Engineering
Civil Engineering – Environmental & Water Studies Specialty
2014–2015 Program Sheet

— ABET Accreditation Criteria Apply —

Final version of completed and signed program sheet due to the department no later than one month prior to the last quarter of senior year.

Follow all requirements as stated for the year of the program sheet used.

Name: _____
 Phone: _____
 Today's Date: _____

SU ID #: _____
 Email: _____
 Month/Yr B.S. expected: _____

Mathematics and Science Requirements

Dept	Course	Title	Transfer/AP Approval by SoE			Units	Grade
			✓ if Transfer	SoE Initials	Date		
<i>Mathematics</i>							
Math	41	Calculus (or AP credit)				5	
Math	42	Calculus (or AP credit)				5	
CME	100	Vector Calculus (or Math 51) (req'd) (note 1)				5	
CME	102	Math/Comp. Methods (or Math 53) (req'd) (note 1)				5	
		Statistical Methods (STATS 60, 110, EESS 160, CEE 203 or CME 106)				4-5	
<i>Mathematics Unit Total</i>							

Science

PHYS	41	Mechanics (req'd) (or AP credit)				4	
CHEM	31B/X	(or ENGR 31) Chemical Principles (req'd) (see note 2)				4-5	
CHEM	33	Structure and Reactivity (req'd)				5	
GES	1A/B/C	Introduction to Geology (1 course req'd)				4-5	
		One other physics or chemistry class from SoE-approved list; may count CHEM 31A				3-5	
<i>Science Unit Total</i>							

Mathematics and Science Unit Total (45 units minimum)

Technology in Society Requirement (1 course required; see UGHB, Fig. 3-3 for SoE approved list)

--	--	--	--	--	--	--	--

NOTES

- * All courses listed on this form must be taken for a letter grade if offered by the instructor.
 - * Read all emails from the Office of Student Affairs; this is the SoE's only method of conveying key information to Engr majors.
 - * This form is available as an Excel file at <http://ughb.stanford.edu/>; you must use a PS from a year you are enrolled at SU. The printed form must be signed by the advisor and, if required, by the dept representative. Changes must be initialed in ink.
 - * All courses listed on this form must only be included under one category; no doublecounting.
 - * Minimum Combined GPA for all courses in Engineering Topics is 2.0.
 - * Transfer and AP credits in Math, Science, Funds., & TIS must be approved by the SoE Dean's office. Transfer credits in Engr Depth must be approved by the Advisor. Transfer credit information and petitions are available at <http://ughb.stanford.edu/t>
 - * When filling out this form, delete courses/units not taken so totals are correct.
- (1) Either CME 100 & 102 OR Math 51 & 53 are required.
- (2) This chemistry requirement may be satisfied by either Chem 31A, Chem 31X, or ENGR 31 (OR by AP Chem, if 4 units of credit are given AND chemistry placement exam allows direct entry into Chem 33).

program sheet continues on page 2

Civil Engineering Program Sheet – Environ. & Water Studies Track (continued)

Engineering Topics (Fundamentals + Depth combined must equal 68 units. See note 3)

Dept	Course	Title	Transfer/AP Approval by SoE			Units	Grade
			✓ if Transfer	SoE Initials	Date		
Engineering Fundamentals (3 courses required)							
ENGR	14	Introduction to Solid Mechanics (req'd)				4	
ENGR	90	Environmental Science & Technology (req'd) (Cross-listed as CEE 70)				3	
ENGR		(ENGR 30, or other ENGR Fundamental)					
<i>Engineering Fundamentals Unit Total</i>							
Engineering Depth							
CEE	146A	(or ENGR 60) Engineering Economy (req'd)				3	
CEE	100	Managing Sustainable Building Projects (req'd) WIM				4	
CEE	101A	Mechanics of Materials (req'd)				4	
CEE	101B	Mechanics of Fluids (req'd)				4	
CEE	101C	Geotechnical Engineering (req'd)				4	
CEE	101D	Computations in Civil and Environmental Engineering (req'd)				3	
CEE	160	Mechanics of Fluids Laboratory (req'd)				2	
CEE	161A	Rivers, Streams and Canals (req'd)				4	
CEE	166A	Watersheds and Wetlands (req'd)				3	
CEE	166B	Floods and Droughts, Dams and Aqueducts (req'd)				3	
CEE	171	Environmental Planning Methods (req'd)				3	
CEE	172	Air Quality Management (req'd)				3	
CEE	177	Aquatic Chemistry and Biology (req'd)				4	
CEE	179A	Water Chemistry Lab (req'd)				3	
CEE		Capstone design class (CEE169 or 179C) (req'd)				5	
CEE		1st Specialty elective course (2-4 units)					
CEE		2nd Specialty elective course (total for 2 specialty electives >= 6 units)					
ENGR	30	(req'd; list here only if not listed above under Fundamentals)					
		Add'l ENGR Elective(s), if needed, to reach 68 units of approved Fund + depth (note 3)					
<i>Engineering Depth Unit Total</i>							

Program Totals (ABET Requirements)

Mathematics and Science (45 units minimum)

Engineering Topics (Engr Fundamentals + Engr Depth) (68 units minimum)

--	--

Program Approvals

Advisor

Printed Name: _____

Date: _____

Signature: _____

Departmental

Printed Name: _____

Date: _____

Signature: _____

School of Engineering (No action required-office use only)

Printed Name: _____

Date: _____

Signature: _____

NOTES (continued from page 1)

- (3) In order to satisfy ABET requirements for graduation, the CEE major must take enough courses so that the combined units from Fundamentals and Depth courses add up to a minimum of 68 units.

COMPUTER SCIENCE

Looking at technology today, it is hard to believe that the first computers were developed only seventy years ago. Computers are everywhere, and much of modern engineering involves the application of computer technology. The undergraduate major in computer science offers a broad and rigorous training for students interested in the science of computing. The track structure of the CS program also allows you to pursue the area(s) of CS you find most interesting while giving you a solid overall foundation in the field.

Many students obtaining a BS in CS will go on to work in industry or do graduate work in a branch of CS such as artificial intelligence, robotics, software design, graphics, theory, or hardware design. But CS is not just for future computer scientists. There is an increasing demand for people trained in CS and some other field. If you are interested in working as a manager of a high-tech company, a BS in CS along with an MBA is a great combination. If you want to work on court cases involving software piracy, you will be well served by a BS in CS combined with a JD. Similar opportunities exist for those who combine a BS in CS with an MD or other graduate degree.

The minimum major in computer science consists of 96 units, including 26 units of math, 11 units of science, 13 units of engineering fundamentals, one course in TIS (Technology in Society), and 43 units of core depth. After learning essential programming techniques in CS106 (via the CS106A/B/X courses) and the mathematical foundations of computer science in CS103, the computer science major offers coursework in areas such as artificial intelligence, biocomputation, computer engineering, graphics, human-computer interaction, information, systems, and theory.

The Computer Science Department also participates in two interdisciplinary majors: Mathematical and Computational Sciences, and Symbolic Systems.

Joint Majors in CS + one of 10 Humanities majors: Only CS requirements are given here; follow special instructions in the footnotes of the charts that follow. For further detail on the degrees and how to declare, go to the [Explore Degrees](#) website, School of Engineering, CS Joint Majors.

UNDERGRADUATE RESEARCH OPPORTUNITIES

In addition to the honors program in CS (discussed later in this handbook), there are many opportunities for undergraduates to get involved in research. Here is a partial list:

CURIS (Undergraduate Research in Computer Science)

Each summer undergraduates work with CS faculty through the summer research college. Interested students apply for positions during the winter quarter, and CURIS decisions are then made and offers sent out before spring quarter begins. These positions are fully-funded and provide invaluable experience in cutting-edge research. All CS students are notified via email of CURIS opportunities and the application process.

Research Opportunities for Computer Science Undergraduates

At the beginning of each academic year CS faculty are asked to provide a list of ongoing research projects that are appropriate for undergraduate involvement. Descriptions of the projects are listed at <http://cs.stanford.edu/researchopp>.

Research Tour/Lunch Series

Each year the CS department offers research lab tours and luncheons specifically geared toward undergraduates. These tours allow students to experience first-hand what goes on in a lab, and the luncheons provide an opportunity for students to discuss interests with research faculty. Past tours included the AI Robotics Lab, the IRoom and the Graphics Lab.

Research Seminars and Talks

At various times throughout the year the CS department hosts talks and presentations on various research and technology topics. In addition to these one-time events, there are regularly scheduled seminars which are open to undergraduates. Many of these seminars are available as 1 unit, 500-level courses, but enrollment is not required for attendance.

For students interested in Pursuing a Research-Oriented Undergraduate Program:

Freshman and Sophomore Year

Students interested in pursuing research should plan to finish the majority of the CS core (CS 103, 106, 107, 109, 110, and 161) by the end of the sophomore year. If you already have an idea of the area in CS you'd like to pursue, you may find these course suggestions useful:

If you're considering...	...make sure to take these freshman/sophomore year
Possible AI courses	CS 109
Possible graphics courses	Math 51 and/or Math 104
Possible theory courses	CS 109, CS 154, or CS 161

Students doing summer research through CURIS should expect to take a course or two spring quarter to prepare them for their research project.

Junior Year

During the junior year students considering research can take one of the following sequences:

Field of Interest	Fall	Winter	Spring
Artificial Intelligence	221	Any 22x	Coursework suggested by CURIS advisor
Databases	145	245	
Graphics	148	248	
Human-Computer Interaction	147	247	
Systems	144	140	
Theory	157 and 161	259	

Students doing summer research through CURIS should expect to take a course or two spring quarter to prepare them for their research project.

Senior Year

At the end of the junior year students who qualify are encouraged to apply for the CS honors program (see the Computer Science ‘honors’ section later in this handbook). Students who are accepted spend the senior year exploring a research topic in depth and writing an honors thesis. Alternatively, students may choose to take CS 294 if they do not have a specific project in mind but wish to contribute to active research.

Note: The above are meant to be taken only as suggestions. If you have questions, contact the CS course advisor at advisor@cs.stanford.edu.

REQUIREMENTS

Course	Title	Units	Quarter	Year
Mathematics (26 units minimum)				
MATH 41	Calculus ¹	5	A	Fr
MATH 42	Calculus ¹	5	AW	Fr
CS 103	Mathematical Foundations of Computing	5	AWS	Fr
CS 109	Introduction to Probability for Computer Scientists	5	WS	So
Mathematics electives ²		6		
Science (11 units minimum)				
PHYSICS 41	Mechanics (or PHYSICS 21 or 61)	4	W	Fr
PHYSICS 43	Electricity and Magnetism (or PHYSICS 23 or 63)	4	S	Fr
Science Elective ³		3		So/Jr
Engineering Fundamentals (13 units minimum)				
ENGR 40 ⁴ or	Introductory Electronics	5	W	So
ENGR 40A or	Introductory Electronics (7 weeks)	3	W	So
ENGR 40M	Making Stuff: What is EE	3-5	A,S	So
CS 106B or	Programming Abstractions	5	AWSSum	Fr/So
CS 106X	Programming Abstractions (Accelerated)	5	AW	Fr/So
Fundamentals Elective (see list of approved courses in Fig. 3-4; may not be 106A, B or X)				
Technology in Society (One course, 3-5 units)				
<i>See list of approved courses in Figure 3-3.</i>				
Writing in the Major (One course)				
<i>CS 181W, CS 191W, CS 194W, CS 210B, and CS 294W fulfill the "Writing in the Major" requirement.</i>				
Core (15 units)				
CS 107	Computer Organization and Systems	5	AWS	So
CS 110	Principles of Computer Systems	5	AWS	So/Jr
CS 161	Design and Analysis of Algorithms	5	AS	So/Jr
Senior Project: CS 191, 191W, 194, 194W, 210B, 294, or 294W ⁵		3		Sr
Depth: Choose one of the following tracks: minimum of 7 courses (25 units minimum required)				
Artificial Intelligence Track:				
a) CS 221				
b) Any two of: CS 223A, 224M, 224N, 228, 229, 131 or 231A				
c) One additional course from category (b) or the following: CS 124, 205A, 222, 224S, 224U, 224W, 225A, 225B, 227B, 213A (if not taken for Track Requirement B) 231B, 231M262, 276, 277, 279, 327A, 329 (with advisor approval), 331A, 374, 379 (with advisor approval); EE 263, 376A; ENGR 205, 209A; MS&E 251, 339, 351; Stat 315A, 315B				
d) Track Electives: At least three additional courses selected from (b), (c), the general CS electives list ⁶ , or the following: CS 275, 278, CS 334A or EE 364A; EE 364B; ECON 286; MS&E 252, 352, 355; PHIL152; PSYCH 202, 204A, 204B; STATS 200, 202, 205. (Joint Majors take one additional course, not three.)				
Biocomputation Track: (see Biocomputation Track program sheet; Mathematics, Science, and Engineering Fundamentals requirements are non-standard)				

Computer Engineering Track:

- a) EE 108, 180
- b) Any two of: EE 101A, 101B, 102A, 102B. (Joint Majors take one course, not two.)
- c) Satisfy the requirements of one of the following concentrations:
 - 1. Digital Systems concentration:
CS 140 or 143; EE 109, 271
Any two of: CS140 or 143 (if not counted above), 144, 149, 240E, 244; EE 273, 282. (Joint Majors take one course, not two.)
 - 2. Robotics and Mechatronics concentration:
CS 205A, 223A; ME 210, ENGR 105
Any one of: CS 225A, 225B, 231A, 235, 277; ENGR 205, 207A, 207B. (Joint Majors do not need to take one of these courses.)
 - 3. Networking concentration:
CS 140, 144
Any three of: CS 240, 240E, 244, 244B, 244E, 249A, 249B; EE 179, 276. (Joint Majors take two courses, not three.)

Graphics Track:

- a) CS 148, 248
- b) Any one of⁷: CS 205A; CME 104, 108; MATH 52, 113
- c) Any two of: CS 164, 178, 205B, 131 or 231A, 268, 348A, 348B, 448
- d) Track Electives: At least two additional courses selected from (b), (c), the general CS electives list⁶, or the following: ARTSTUDI 160, 170, 179; CME 302, 306; EE 262, 264, 278, 368; ME 101; PSYCH 30, 221. (Joint Majors waive these two electives.)

Human-Computer Interaction Track:

- a) CS 147
- b) Any one of: CS 247, 377, 448B, 210A
- c) Any one of: PSYCH 30, 45, 50, 55, 70, 75, 131, 154, 252; ME 101, 116, or any MS&E 18*
- d) Any one of: CS 108, 124, 140, 142, 221, 229, 229A, 249A
- e) Any one of: CS 148, 376, 378, 447
- f) Track Electives-At least two additional courses selected from (b), (c), (d), (e), the general CS electives list⁶, or the following: ARTSTUDI 160; COMM 169; CS 476A; ME115A, ME 115B; SYMSYS 245. (Joint Majors waive these two electives.)

Information Track:

- a) CS 124, 145
- b) Two courses, which must be from different areas below:
 - i. Information-based AI applications: CS 224N, 224S, 229, 229A
 - ii. Database and Information Systems: CS 140, 142, 245, 246, 341, 345, 346, 347
 - iii. Information Systems in Biology: CS262, 270, 274
 - iv. Information Systems on the Web: CS 224W, 276, 364B
- c) At least three additional courses selected from (b) or the general CS electives list.⁶ (Joint Majors take one course, not three.)

Systems Track:

- a) CS 140
- b) One of: CS 143 or EE 180
- c) Two additional courses from category (b) or the following: CS 144, 145, 149, 155, 240, 242, 243, 244, 245; EE 271, 282
- d) Track Electives: At least three additional courses selected from (c), the general CS electives list⁶, or the following: CS 240E, 244C, 244E, 315A or 316, 315B, 341, 343, 344, 344E, 345, 346, 347, 349 (with advisor approval), 448; EE 382C, 384A, 384B, 384C, 384S, 384X. (Joint Majors take one elective, not three.)

<p>Theory Track:</p> <p>a) CS 154</p> <p>b) Any one of: CS 164, 167, 168, 255, 258, 261, 264, 265, 268, 361A, 361B</p> <p>c) Two additional courses from category (b) or the following: CS 143, 155, 157 or Phil 151, 166, 205A, 228, 242, 254, 259 (with advisor approval), 262, 266, 267, 354, 355, 357, 358, 359 (with advisor approval), 364A, 364B, 366, 367, 369 (with advisor approval), 374; MS&E 310</p> <p>d) Track Electives: At least three additional courses selected from (b), (c), the general CS electives list⁶, or the following: CME 302, 305; Phil 152 (Joint Majors take one course, not three.)</p>
<p>Unspecialized Track:</p> <p>a) CS 154</p> <p>b) Any one of: CS 140, 143</p> <p>c) One additional course from (b) or the following: CS 144, 155, 242, 244; EE 180</p> <p>d) Any one of: CS 121 or 221, 223A, 228, 229, 231A</p> <p>e) Any one of: CS 145, 147, 148, 248, 262</p> <p>f) At least two courses from the general CS electives list⁶ (Joint Majors waive these two courses)</p>
<p>Individually Designed Track: Students may propose an individually designed track. Proposals should include a minimum of seven courses, at least four of which must be CS courses numbered 100 or above</p>

Notes:

1. MATH 19, 20 and 21 or AP Calculus may be used instead of MATH 41 and 42, as long as at least 26 math units are taken.
2. The Mathematics electives list consists of: Math 51, 104, 108, 109, 110, 113; CS 157, 205A; PHIL 151; CME 100, 102, 104. Completion of Math 52 and 53 will (together) count as one Math elective. Restrictions: CS 157 and PHIL 151 may not be used in combination to satisfy the Math electives requirement. Students who have taken both Math 51 and 52 may not count CME 100 as an elective.
3. Any course of 3 or more units from the School of Engineering list of “Courses Approved for the Science Requirement” (Figure 3-2); PSYCH 30; PSYCH 55, or AP Chemistry credit may also be used. Either of the physics sequences 61/63 or 21/23 may be substituted for 41/43 as long as at least 11 science units are taken.
4. Students who complete ENGR 40A, or take 40M for fewer than 5 units, are required to complete one-two additional units of Engineering Fundamentals (13 units minimum), or one-two additional units of Depth (27 units minimum for track and elective courses).
5. CS 191 and 191W independent study projects require faculty sponsorship and must be approved, in advance, by the advisor, faculty sponsor, and the CS senior project advisor (Patrick Young). A form bearing these signatures, along with a brief description of the project, should be filed with the department representative in Gates 193 the quarter before work on the project is begun.
6. General CS Electives: CS 108, 121 or 221, 124, 131, 140, 142, 143, 144, 145, 147, 148, 149, 154, 155, 156, 157 or Phil 151, 164, 166, 167, 168, 190, 205A, 205B, 210A, 222, 223A, 224M, 224N, 224S, 224U, 224W, 225A, 225B, 227B, 228, 228T, 229, 229A, 229T, 231A, 231B, 231M, 232, 240, 240H, 241, 242, 243, 244, 244B, 245, 246, 247, 248, 249A, 249B, 254, 255, 258, 261, 262, 263, 264, 265, 266, 267, 270, 271, 272, 173 or 273A, 274, 276, 277, 279, 295, 348B; CME 108; EE 180, 282, 364A.

7. Of the category (b) options for the Graphics track, CS 205A is strongly recommended as a preferred choice. Note that students taking CME 104 are also required to take its prerequisite course CME 102.

Note: The online version of your major (link from the Home or Major Programs page of the UGHB website) is considered the definitive version of 2014-15 requirements; corrections or updates may have been made after the printed and pdf versions were published in August 2014.

- ★ You must use a program sheet from a year you have been enrolled at Stanford.

Computer Science

*Typical Sequence of Courses
Unspecialized Track*

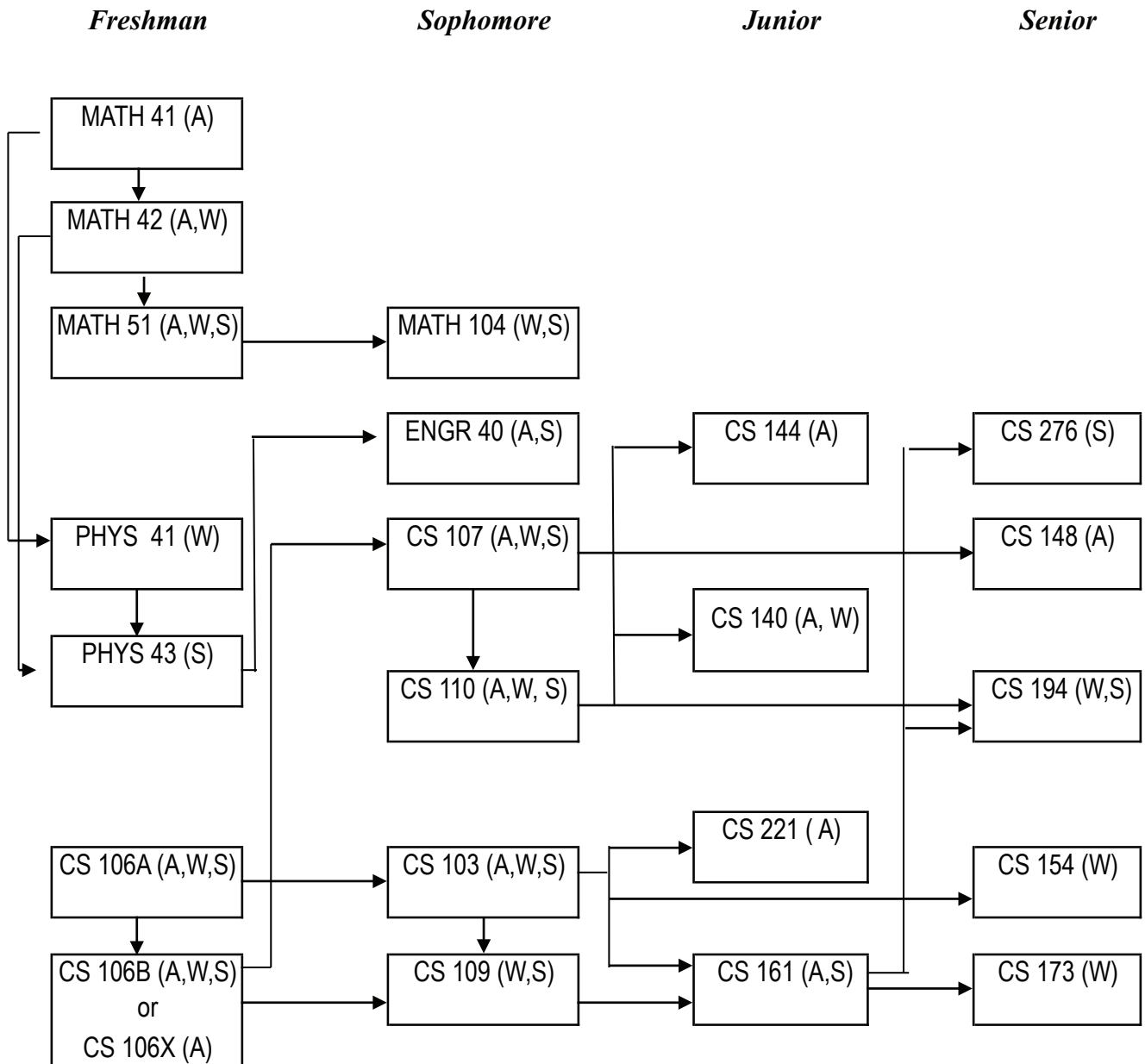

Computer Science

Artificial Intelligence Track

	<i>Fall</i>			<i>Winter</i>			<i>Spring</i>					
	Math/ Sci.	Engr.	Other	Class	Math/ Sci.	Engr.	Other	Class	Math/ Sci.	Engr.	Other	
<i>Freshman</i>	CS 106A	-	5	-	CS 106B	-	5	-	CS 103	5	-	-
	Math 41	5	-	-	PHYSICS 41	4	-	-	PHYSICS 43	4	-	-
	THINK	-	-	4	Math 42	5	-	-	Intro Sem	-	-	3
	Writing	-	-	4					WAYS/elective	-	-	3
	<i>Subtotals</i>	5	5	8	<i>Subtotals</i>	9	5	0	<i>Subtotals</i>	9	0	6
Total			18	Total			14	Total			15	
<i>Sophomore</i>	CS 107	-	5	-	CS 109	5	-	-	CS elective	-	4	-
	Math elective	4	-	-	CS 110	-	5	-	ENGR 40M	-	5	-
	Language	-	-	5	Language	-	-	5	Language	-	-	5
	Writing	-	-	4					Sci. elective	3	-	-
	<i>Subtotals</i>	4	5	9	<i>Subtotals</i>	5	5	5	<i>Subtotals</i>	3	9	5
Total			18	Total			15	Total			17	
<i>Junior</i>	CS 221	-	4	-	CS 124	-	4	-	CS 161	-	5	-
	CS elective	-	4	-	CS elective	-	4	-	TIS course	-	-	4
	WAYS/elective	-	-	5	WAYS/elective	-	-	5	WAYS/elective	-	-	5
	<i>Subtotals</i>	0	8	5	<i>Subtotals</i>	0	8	5	<i>Subtotals</i>	0	5	9
	Total			13	Total			13	Total			14
<i>Senior</i>	CS 224N	-	4	-	Math elective	4	-	-	CS 194W	-	3	-
	WAYS/elective	-	-	5	CS 228	-	4	-	WAYS/elective	-	-	5
	Fund elective	-	3	-	WAYS/elective	-	-	4	WAYS/elective	-	-	4
					WAYS/elective	-	-	4	WAYS/elective	-	-	3
	<i>Subtotals</i>	0	7	5	<i>Subtotals</i>	4	4	8	<i>Subtotals</i>	0	3	12
Total			12	Total			16	Total			15	

Total Math & Science Units: 39
 Total Engineering Units: 64
 Total Other Units: 77
Total Units: 180

Computer Science

Biocomputation Track

	<i>Fall</i>			<i>Winter</i>			<i>Spring</i>					
	Math/ Sci.	Engr.	Other	Class	Math/ Sci.	Engr.	Other	Class	Math/ Sci.	Engr.	Other	
<i>Freshman</i>	CS 106A	-	5	-	CS 106B	-	5	-	CS 103	5	-	-
	Math 41	5	-	-	Math 42	5	-	-	Writing	-	-	4
	Chem 31A	4	-	-	Chem 31B	4	-	-	CHEM 33	4	-	-
	THINK	-	-	4						-	-	
	<i>Subtotals</i>	9	5	4	<i>Subtotals</i>	9	5	0	<i>Subtotals</i>	9	0	4
Total			18	Total			14	Total			13	
<i>Sophomore</i>	CS 107	-	5	-	CS 110	-	5	-	CS 109	5	-	-
	BIO 41	5	-	-	BIO 42	5	-	-	Language	-	-	5
	Language	-	-	5	Language	-	-	5	Writing	-	-	4
	WAYS/elective	-	-	3								
	<i>Subtotals</i>	5	5	8	<i>Subtotals</i>	5	5	5	<i>Subtotals</i>	5	0	9
Total			18	Total			15	Total			14	
<i>Junior</i>	CS 161	-	5	-	STAT 215	3	-	-	CS elective	-	3	-
	CS 145	-	4	-	PHYS 41	4	-	-	Fund elective	-	5	-
	WAYS/elective	-	-	4	WAYS/elective	-	-	4	WAYS/elective	-	-	3
					WAYS/elective	-	-	3	TIS elective	-	-	3
	<i>Subtotals</i>	0	9	4	<i>Subtotals</i>	7	0	7	<i>Subtotals</i>	0	8	6
Total			13	Total			14	Total			14	
<i>Senior</i>	CS 148	-	4	-	CS 173	-	3	-	CS 275	-	4	-
	CS 221	-	4	-	HUM BIO 133	4	-	-	CS 191W	-	3	-
	WAYS/elective	-	-	5	WAYS/elective	-	-	5	WAYS/elective	-	-	4
	WAYS/elective	-	-	4	WAYS/elective	-	-	4	WAYS/elective	-	-	3
	<i>Subtotals</i>	0	8	9	<i>Subtotals</i>	4	3	9	<i>Subtotals</i>	0	7	7
Total			17	Total			16	Total			14	

Total Math & Science Units: 53
 Total Engineering Units: 55
 Total Other Units: 72
Total Units: 180

Computer Science

Computer Engineering Track (Networking Concentration)

	<i>Fall</i>				<i>Winter</i>				<i>Spring</i>			
	Math/ Sci.	Engr.	Other		Math/ Sci.	Engr.	Other		Math/ Sci.	Engr.	Other	
<i>Freshman</i>	Class				Class				Class			
	CS 106A	-	5	-	CS 106B	-	5	-	CS 103	5	-	-
	Math 41	5	-	-	Math 42	5	-	-	PHYSICS 43	4	-	-
	THINK	-	-	4	Physics 41	4	-	-	ENGR 40M	4	-	-
	Writing	-	-	4					Intro Sem			3
	<i>Subtotals</i>	5	5	8	<i>Subtotals</i>	9	5	0	<i>Subtotals</i>	13	0	3
	Total			18	Total			14	Total			16
<i>Sophomore</i>	CS 107	-	5	-	CS 109	5	-	-	CS 161	-	5	-
	Math elective	3	-	-	CS 110	-	5	-	Sci. elective	3	-	-
	Language	-	-	5	Language	-	-	5	Language	-	-	5
	Writing	-	-	4	WAYS/elective	-	-	3	WAYS/elective	-	-	3
	<i>Subtotals</i>	3	5	9	<i>Subtotals</i>	5	5	8	<i>Subtotals</i>	3	5	8
	Total			17	Total			18	Total			16
<i>Junior</i>	CS elective	-	4	-	EE 180	-	4	-	CS 240	-	3	-
	EE108	-	4	-	CS 140	-	4	-	TIS course	-	-	4
	WAYS/elective	-	-	5	WAYS/elective	-	-	5	WAYS/elective	-	-	3
	<i>Subtotals</i>	0	8	5	<i>Subtotals</i>	0	8	5	<i>Subtotals</i>	0	3	9
	Total			13	Total			13	Total			12
<i>Senior</i>	CS 144	-	4	-	EE 101A	-	4	-	CS 194W	-	3	-
	CS 249A	-	3	-	CS 244	-	4	-	EE 101B	-	4	-
	Fund elective	-	4	-	Math elective	4	-	-	WAYS/elective	-	-	5
	WAYS/elective	-	-	4	WAYS/elective	-	-	4				
	<i>Subtotals</i>	0	11	4	<i>Subtotals</i>	4	8	4	<i>Subtotals</i>	0	7	5
	Total			15	Total			16	Total			12

Total Math & Science Units: 42
 Total Engineering Units: 70
 Total Other Units: 68
Total Units: 180

Computer Science

Graphics Track

	<i>Fall</i>				<i>Winter</i>				<i>Spring</i>			
	Math/ Sci.	Engr.	Other	Class	Math/ Sci.	Engr.	Other	Class	Math/ Sci.	Engr.	Other	
<i>Freshman</i>	CS 106A	-	5	-	CS 106B	-	5	-	CS 103	5	-	-
	Math 41	5	-	-	Math 42	5	-	-	PHYSICS 43	4	-	-
	THINK	-	-	4	Physics 41	4	-	-	ENGR 40M	-	5	-
	Writing	-	-	4	WAYS/elective	-	-	4	Intro Sem	-	-	3
	<i>Subtotals</i>	5	5	8	<i>Subtotals</i>	9	5	4	<i>Subtotals</i>	9	5	3
	Total			18	Total			18	Total			17
<i>Sophomore</i>	CS 107	-	5	-	CS 110	-	5	-	CS 109	5	-	-
	MATH 51	5	-	-	WAYS/elective	-	-	3	CS elective	-	4	-
	Language	-	-	5	Language	-	-	5	Language	-	-	5
	Writing	-	-	4								
	<i>Subtotals</i>	5	5	9	<i>Subtotals</i>	0	5	8	<i>Subtotals</i>	5	4	5
	Total			19	Total			13	Total			14
<i>Junior</i>	CS elective	-	3	-	CS 248	-	4	-	CS 178	-	5	-
	CS 148	-	4	-	WAYS/elective	-	-	4	CS elective	-	3	-
	Sci. Elective	4	-	-	WAYS/elective	-	-	3	WAYS/elective	-	-	3
	WAYS/elective	-	-	3	WAYS/elective	-	-	3	WAYS/elective	-	-	3
	<i>Subtotals</i>	4	7	3	<i>Subtotals</i>	0	4	10	<i>Subtotals</i>	0	8	6
	Total			14	Total			14	Total			14
<i>Senior</i>	CS 161	-	5	-	TIS course	-	-	5	CS 194W	-	3	-
	CS 205A	-	3	-	Fund Elective	-	3	-	CS 348B	-	4	-
	WAYS/elective	-	-	4	WAYS/elective	-	-	4	Math elective	5	-	-
									WAYS/elective	-	-	3
	<i>Subtotals</i>	0	8	4	<i>Subtotals</i>	0	3	9	<i>Subtotals</i>	5	7	3
	Total			12	Total			12	Total			15

Total Math & Science Units: 42
 Total Engineering Units: 66
 Total Other Units: 72
Total Units: 180

Computer Science

Human-Computer Interaction Track (including quarter abroad)

	<i>Fall</i>				<i>Winter</i>				<i>Spring</i>			
	Math/				Math/				Math/			
	Class	Sci.	Engr.	Other	Class	Sci.	Engr.	Other	Class	Sci.	Engr.	Other
<i>Freshman</i>	CS 106A	-	5	-	CS 106B	-	5	-	CS 107	-	5	-
	Math 41	5	-	-	Math 42	5	-	-	PHYSICS 43	4	-	-
	THINK	-	-	4	Physics 41	4	-	-	Intro Sem	-	-	3
	Writing	-	-	4					WAYS/elective	-	-	3
	<i>Subtotals</i>	5	5	8	<i>Subtotals</i>	9	5	0	<i>Subtotals</i>	4	5	6
Total			18	Total			14	Total			15	
<i>Sophomore</i>	CS 103	5	-	-	CS 109	5	-	-	CS 110	-	5	-
	CS 147	-	4	-	CS 247	-	4	-	ME 101	-	3	-
	Fund Elect	-	3	-	Language	-	-	5	Math elective	3	-	-
	Language	-	-	5	Writing	-	-	4	Language	-	-	5
	<i>Subtotals</i>	5	7	5	<i>Subtotals</i>	5	4	9	<i>Subtotals</i>	3	8	5
Total			17	Total			18	Total			16	
<i>Junior</i>	CS 148	-	4	-	CS 108	-	4	-	(Quarter abroad)			
	Math elective	5	-	-	CS elective	-	4	-	ENGR 40	-	5	-
	WAYS/elective	-	-	3	WAYS/elective	-	-	5	OSP	-	-	4
									OSP	-	-	4
	<i>Subtotals</i>	5	4	3	<i>Subtotals</i>	0	8	5	<i>Subtotals</i>	0	5	8
Total			12	Total			13	Total			13	
<i>Senior</i>	CS elective	-	5	-	CS 161	-	5	-	CS 194W	-	3	-
	Sci Elective	3	-	-	TIS course	-	4	-	WAYS/elective	-	-	3
	WAYS/elective	-	-	4	WAYS/elective	-	-	4	WAYS/elective	-	-	4
	WAYS/elective	-	-	3	WAYS/elective	-	-	3	WAYS/elective	-	-	3
	<i>Subtotals</i>	3	5	7	<i>Subtotals</i>	0	9	7	<i>Subtotals</i>	0	3	10
Total			15	Total			16	Total			13	

Total Math & Science Units: 39
 Total Engineering Units: 68
 Total Other Units: 73
Total Units: 180

Computer Science Information Track

	<i>Fall</i>				<i>Winter</i>				<i>Spring</i>			
	Math/ Sci.	Engr	Other		Math/ Sci.	Engr	Other		Math/ Sci.	Engr	Other	
<i>Freshman</i>	CS 106X	-	5	-	Math 42	5	-	-	CS 103	5	-	-
	Math 41	5	-	-	Physics 41	4	-	-	Physics 43	4	-	-
	THINK	-	-	4	GER	-	-	4	Intro Sem	-	-	3
	Writing	-	-	4					WAYS/elective	-	-	4
	<i>Subtotals</i>	5	5	8	<i>Subtotals</i>	9	0	4	<i>Subtotals</i>	9	0	7
Total			18	Total			13	Total			16	
<i>Sophomore</i>	CS 107	-	5	-	CS 109	5	-	-	CS elective	-	4	-
	Math elective	4	-	-	CS 110	-	5	-	ENGR 40M	-	5	-
	Language	-	-	5	Language	-	-	5	Language	-	-	5
	Writing	-	-	4								
	<i>Subtotals</i>	4	5	9	<i>Subtotals</i>	5	5	5	<i>Subtotals</i>	0	9	5
Total			18	Total			15	Total			14	
<i>Junior</i>	CS 161	-	5	-	CS 124	-	4	-	CS 276	-	3	-
	CS elective	-	4	-	TIS course	-	-	4	Math elective	5	-	-
	WAYS/elective	-	-	5	WAYS/elective	-	-	5	CS elective	-	5	-
	<i>Subtotals</i>	0	9	5	<i>Subtotals</i>	0	4	9	<i>Subtotals</i>	5	8	0
Total			14	Total			13	Total			13	
<i>Senior</i>	CS 145	-	4	-	CS 245	-	4	-	CS 210B	-	4	-
	WAYS/elective	-	-	5	Sci. elective	3	-	-	WAYS/elective	-	-	5
	WAYS/elective	-	-	4	CS 210A	-	3	-	WAYS/elective	-	-	4
	WAYS/elective	-	-	3	WAYS/elective	-	-	4	Fund elective	-	3	-
	<i>Subtotals</i>	0	4	12	<i>Subtotals</i>	3	7	4	<i>Subtotals</i>	0	7	9
Total			16	Total			14	Total			16	

Total Math & Science Units: 40
 Total Engineering Units: 63
 Total Other Units: 77
Total Units: 180

Computer Science Systems Track

	<i>Fall</i>				<i>Winter</i>				<i>Spring</i>			
	Math/ Sci.	Engr.	Other		Math/ Sci.	Engr.	Other		Math/ Sci.	Engr.	Other	
<i>Freshman</i>	CS 106A	-	5	-	CS 106B	-	5	-	CS 103	5	-	-
	Math 41	5	-	-	Math 42	5	-	-	PHYSICS 43	4	-	-
	THINK	-	-	4	Physics 41	4	-	-	Intro Sem	-	-	3
	Writing	-	-	4					WAYS/elective	-	-	3
	<i>Subtotals</i>	5	5	8	<i>Subtotals</i>	9	5	0	<i>Subtotals</i>	9	0	6
Total			18	Total			14	Total			15	
<i>Sophomore</i>	CS 107	-	5	-	CS 109	5	-	-	CS elective	-	4	-
	Math elective	3	-	-	CS 110	-	5	-	ENGR 40M	-	5	-
	Language	-	-	5	Language	-	-	5	Language	-	-	5
	Writing	-	-	4								
	<i>Subtotals</i>	3	5	9	<i>Subtotals</i>	5	5	5	<i>Subtotals</i>	0	9	5
Total			17	Total			15	Total			14	
<i>Junior</i>	CS 161	-	5	-	CS 140	-	4	-	CS 155	-	3	-
	CS 144	-	4	-	Math elective	5	-	-	CS 143	-	4	-
	WAYS/elective	-	-	5	WAYS/elective	-	-	5	WAYS/elective	-	-	5
	<i>Subtotals</i>	0	9	5	<i>Subtotals</i>	5	4	5	<i>Subtotals</i>	0	7	5
Total			14	Total			14	Total			12	
<i>Senior</i>	CS elective	-	4	-	CS 210A	-	4	-	CS 210 B	-	4	-
	CS elective	-	4	-	Fund elective	-	3	-	WAYS/elective	-	-	4
	TIS elective	-	-	5	WAYS/elective	-	-	5	WAYS/elective	-	-	4
	Sci elective	4	-	-	WAYS/elective	-	-	3	WAYS/elective	-	-	3
	<i>Subtotals</i>	4	8	5	<i>Subtotals</i>	0	7	8	<i>Subtotals</i>	0	4	11
Total			17	Total			15	Total			15	

Total Math & Science Units: 40
Total Engineering Units: 68
Total Other Units: 72
Total Units: 180

Computer Science Theory Track

	<i>Fall</i>				<i>Winter</i>				<i>Spring</i>			
	Class	Math/ Sci.	Engr.	Other	Class	Math/ Sci.	Engr.	Other	Class	Math/ Sci.	Engr.	Other
<i>Freshman</i>	CS 106X	-	5	-	MATH 42	5	-	-	CS 103	5	-	-
	Math 41	5	-	-	PHYSICS 41	4	-	-	PHYSICS 43	4	-	-
	THINK	-	-	4	Intro Sem	-	-	3	WAYS/elective	-	-	4
	Writing	-	-	4	WAYS/elective	-	-	5				
	<i>Subtotals</i>	5	5	8	<i>Subtotals</i>	9	0	8	<i>Subtotals</i>	9	0	4
Total			18	Total			17	Total			13	
<i>Sophomore</i>	CS 107	-	5	-	CS 109	5	-	-	CS elective	-	4	-
	Math elective	5	-	-	CS 110	-	5	-	ENGR 40M	-	5	-
	Language	-	-	5	Language	-	-	5	Language	-	-	5
	Writing	-	-	4								
	<i>Subtotals</i>	5	5	9	<i>Subtotals</i>	5	5	5	<i>Subtotals</i>	0	9	5
Total			19	Total			15	Total			14	
<i>Junior</i>	CS 161	-	5	-	CS 154	-	4	-	CS 181W	-	4	-
	CS elective	-	4	-	CS 261	-	3	-	CS elective	-	5	-
	WAYS/elective	-	-	5	WAYS/elective	-	-	5	WAYS/elective	-	-	5
					WAYS/elective	-	-	3				
	<i>Subtotals</i>	0	9	5	<i>Subtotals</i>	0	7	8	<i>Subtotals</i>	0	9	5
Total			14	Total			15	Total			14	
<i>Senior</i>	CS 157	-	3	-	CS elective	-	4	-	CS 191	-	3	-
	CS 242	-	3	-	Fund elective	-	3	-	WAYS/elective	-	-	4
	Math elective	4	-	-	WAYS/elective	-	-	3	WAYS/elective	-	-	4
	Sci elective	4	-	-	WAYS/elective	-	-	3	WAYS/elective	-	-	3
	<i>Subtotals</i>	8	6	0	<i>Subtotals</i>	0	7	6	<i>Subtotals</i>	0	3	11
Total			14	Total			13	Total			14	

Total Math & Science Units: 41
 Total Engineering Units: 65
 Total Other Units: 74
Total Units: 180

Computer Science

Unspecialized Track

	<i>Fall</i>			<i>Winter</i>			<i>Spring</i>					
	Math/ Sci.	Engr.	Other	Class	Math/ Sci.	Engr.	Other	Class	Math/ Sci.	Engr.	Other	
<i>Freshman</i>	CS 106A	-	5	-	CS 106B	-	5	-	CS 103	5	-	-
	MATH 41	5	-	-	MATH 42	5	-	-	PHYSICS 43	4	-	-
	THINK	-	-	4	PHYSICS 41	4	-	-	ENGR 40M	-	5	-
	Writing	-	-	4					Intro Sem	-	-	3
	<i>Subtotals</i>	5	5	8	<i>Subtotals</i>	9	5	0	<i>Subtotals</i>	9	5	3
	Total			18	Total			14	Total			17
<i>Sophomore</i>	CS 107	-	5	-	CS 109	5	-	-	CS 143	-	4	-
	Math elective	5	-	-	CS 110	-	5	-	WAYS/elective	-	-	4
	Language	-	-	5	Language	-	-	5	Language	-	-	5
	Writing	-	-	4								
	<i>Subtotals</i>	5	5	9	<i>Subtotals</i>	5	5	5	<i>Subtotals</i>	0	4	9
	Total			19	Total			15	Total			13
<i>Junior</i>	CS 161	-	5	-	CS 154	-	4	-	CS elective	-	4	-
	CS 148	-	4	-	Math elective	5	-	-	CS 181W	-	4	-
	WAYS/elective	-	-	5	WAYS/elective	-	-	5	WAYS/elective	-	-	5
	<i>Subtotals</i>	0	9	5	<i>Subtotals</i>	5	4	5	<i>Subtotals</i>	0	8	5
		Total			14	Total			14	Total		
<i>Senior</i>	CS 144	-	4	-	CS elective	-	4	-	CS 194	-	3	-
	CS 221	-	4	-	Fund elective	-	4	-	WAYS/elective	-	-	3
	TIS elective	-	-	4	WAYS/elective	-	-	5	WAYS/elective	-	-	3
	Sci elective	3	-	-	WAYS/elective	-	-	3	WAYS/elective	-	-	3
	<i>Subtotals</i>	3	8	4	<i>Subtotals</i>	0	8	8	<i>Subtotals</i>	0	3	9
	Total			15	Total			16	Total			12

Total Math & Science Units: 41
 Total Engineering Units: 69
 Total Other Units: 70
Total Units: 180

INSTRUCTIONS FOR DECLARING MAJOR IN COMPUTER SCIENCE

1. Find an Advisor

For details see <http://csmajor.stanford.edu/ChoosingAdvisor.shtml>

Find a CS professor or lecturer who verbally agrees to be your advisor. See

<http://cs.stanford.edu/degrees/undergrad/FacultyList.shtml> for a list of faculty members. You should meet with him or her in person, either in office hours or by appointment. Write your advisor's name here. If you prefer to have an advisor assigned to you by the department, write "any" in the space below

I have spoken
to

--

and he/she has agreed
to be my advisor.

2. Print Transcript and Declare on Axxess

Print out a copy of your unofficial transcript from Axxess (Academics → View Unofficial Transcript). *Please don't staple it.*

I have an unofficial transcript from this quarter.

While you're on Axxess, be sure to declare there. (Academics → Declare a Major/Minor).

I have declared on Axxess.

3. Basic Information

Full Name	First	Middle	Last
Name you go by:		Birth date:	Month: Day: Year:
SUID #		Email @stanford.edu	
Major	<input type="radio"/> CS <input type="radio"/> CSE	Expected graduation	<input type="radio"/> 2015 <input checked="" type="radio"/> 2017 <input checked="" type="radio"/> 2016 <input type="radio"/> 2018 <input type="radio"/> Other:
Date you came to see the Course Advisor:			

4. See the Course Advisor in Gates 160

Bring this form to the Course Advisor's office hours in **Gates 160**. The current quarter's office hours are posted at <http://csmajor.stanford.edu/WhoToSee.shtml>.

NOTE: There are no office hours during finals week, break, or summer quarter. It may take up to a week for a declaration to go through, so please plan accordingly! Juniors should do this before winter quarter.

Stanford University ♦ School of Engineering
Computer Science
Artificial Intelligence Track
2014-2015 Program Sheet

Final version of program sheet due to the department no later than one month prior to the last quarter of senior year.

Follow all requirements as stated for the year of the program sheet used.

Name: _____ SU ID #: _____
 Phone: _____ Email: _____
 Today's Date: _____ Month/Yr B.S. expected: _____

Mathematics and Science Requirement (*Delete courses and units not taken*)

Dept	Course	Title	Transfer/AP Approval by SoE			Unit	Grade
			✓ if Transfer	SoE Initials	Date		
Mathematics (26 units minimum)							
MATH	41	Calculus (see note 1)				5	
MATH	42	Calculus				5	
CS	103	Mathematical Foundations of Computing				5	
CS	109	Introduction to Probability for Computer Scientists				5	
<i>Plus two electives (see note 2)</i>							
<i>Mathematics Unit Total (26 units minimum)</i>							
Science 11 units minimum							
PHYS	41	Mechanics (or PHYS 21 or 61)				4	
PHYS	43	Electricity and Magnetism (or PHYS 23 or 63)				4	
		Elective (see note 3)					
<i>Science Unit Total (11 units minimum)</i>							
<i>(37 units min. Math/Sci combined)</i>							
Technology in Society Requirement (<i>1 course required; see UGHB Figure 3-3 for approved list; see note 10</i>)							
Engineering Fundamentals (13 units minimum)							
CS	106	Programming Abstractions (B or X)				5	
ENGR	40	Introductory Electronics (40A and 40M also allowed; see note 4)				5	
		Elective (See Fig. 3-4 in the UGHB for approved list; CS 106A, B or X not allowed)					
<i>Engineering Fundamentals Total (13 units minimum)</i>							

NOTES

- * **All courses listed on this form must be taken for a letter grade (if offered) and can be included under only one category.**
- * This printed form must be signed by the departmental representative. Changes must be petitioned (see UGHB pg 27-29) and initialed in ink.
- * Minimum Grade Point Average (GPA) for all courses in ENGR Fundamentals and CS Core, Depth, and Senior Project (combined) is 2.0.
- * Transfer and AP credits in Math, Science, Fundamentals, & TIS must be approved by the SoE Dean's Office. Transfer credits in Computer Science Core, Depth and Senior Project must be approved by the Computer Science undergraduate program office.
- * Courses must be taken for the number of units on the Program Sheet. CS 103, 106B/X, 107, 109, 110 and 161 must be taken for 5 units.
- (1) Math 19, 20, 21 may be taken instead of Math 41& 42 as long as at least 26 math units are taken. AP Calculus must be approved by SoE.
- (2) Math electives: Math 51, 104, 108, 109, 110, 113; CS 157, 205A; PHIL 151; CME 100, 102, 104. Completion of Math 52 & 53 will (together) count as one Math elective. Restrictions: CS 157+ Phil 151 may not be used in combination to satisfy the Math electives requirement. Students who have taken both Math 51& 52 may not count CME 100 as an elective.
- (3) Any course of 3 or more units from the SoE Science List (Fig. 3-2 in the UGHB), PSYCH 30 or 55, or AP Chemistry may be used.
- (4) Students who take ENGR 40A or 40M for fewer than 5 units are required to take 1-2 additional units of ENGR Fundamentals (13 units minimum), or 1-2 additional units of Depth (27 units minimum for track and elective courses).

CS Artificial Intelligence Program Sheet (continued)

AI Track Core, Depth & Senior Project (43 units min) No course may be listed twice; no double counting.

Dept	Course	Title	Transfer/Deviation Approval by Dept			Unit	Grade
			✓ if Transfer	Dept Initials	Date		
Core (15 units minimum)							
CS	107	Computer Organization and Systems				5	
CS	110	Principles of Computer Systems				5	
CS	161	Design and Analysis of Algorithms				5	
Depth; Track and Electives (25 units and seven courses minimum)							
CS	221	AI: Principles and Techniques (Track Requirement A)				4	
CS		Track Requirement B (see note 5)					
CS		Track Requirement B (see note 5)					
		Track Requirement C (see note 6)					
		Elective (see note 7)					
		Elective (see note 7)					
		Elective (see note 7)					
		Optional Elective					
Senior Project (1 course required)							
CS		At least 3 units of 191, 191W, 194, 194W, 210B, 294 or 294W (see note 9)				3	
<i>Computer Science Core, Depth and Senior Project Total (43 units minimum)</i>							

Program Approvals

Departmental

Printed Name: _____

Date: _____

Signature: _____

School of Engineering (No action required-office use only)

Printed Name: _____

Date: _____

Signature: _____

NOTES (continued from page 1)

- (5) Track Requirement B: Any two of CS 223A, 224M, 224N, 228, 229, 131 or 231A
- (6) Track Requirement C: One additional course from the Track Requirement B list, or from the following: CS 124, 205A, 222, 224S, 224U, 224W, 225A, 225B, 227B, 231A (if not taken for Track Requirement B), 231B, 231M, 262, 276, 277, 279, 327A, 329 (with advisor approval), 331A, 374, 379 (with advisor approval); EE 263, 376A; ENGR 205, ENGR 209A; MS&E 251, 351; STATS 315A, 315B
- (7) Track Electives: At least three add'l courses selected from the Track Req't B list, C list, the General CS Electives list (see Note 8) or the following: CS 275, 278, CS334A or EE 364A; EE 364B; ECON 286; MS&E 252, 352, 355; PHIL 152; PSYCH 202, 204A, 204B; STATS 200, 202, 205
- (8) General CS Electives: CS 108, 124, 131, 140, 142, 143, 144, 145, 147, 148, 149, 154, 155, 156, 157 (or PHIL 151), 164, 166, 167, 168, 190, 205A, 205B, 210A, 222, 223A, 224M, 224N, 224S, 224U, 224W, 225A, 225B, 227B, 228, 228T, 229, 229A, 229T, 231A, 231B, 231M, 232, 235, 240, 240H, 241, 242, 243, 244, 244B, 245, 246, 247, 248, 249A, 249B, 254, 255, 258, 261, 262, 263, 264, 265, 266, 267, 270, 271, 272, 173 or 273A, 274, 276, 277, 279, 295, 348B; CME 108; EE 180, 282, 364A
- (9) The WIM requirement may be met by taking CS 181W as a Technology in Society course or through the Senior Project course (CS 191W, 194W, 210B, or 294W only).

Stanford University ♦ School of Engineering
Computer Science
Biocomputation Track
2014-2015 Program Sheet

Final version of program sheet due to the department one month prior to the last quarter of senior year.

Follow all requirements as stated for the year of the program sheet used.

Name: _____ SU ID #: _____
 Phone: _____ Email: _____
 Today's Date: _____ Month/YrB.S. expected: _____

Mathematics and Science Requirement

Dept	Course	Title	Transfer/AP Approval by SoE		Unit	Grade
			✓ if Transfer	SoE Initials Date		
<i>Mathematics (23 units minimum)</i>						
MATH	41	Calculus (see note 1)			5	
MATH	42	Calculus			5	
CS	103	Mathematical Foundations of Computing			5	
CS	109	Introduction to Probability for Computer Scientists			5	
STAT		One of: Stat 141, 203, 205, 215				
<i>Mathematics Unit Total (23 units minimum)</i>						

Science (22 units minimum)

PHYS	41	Mechanics			4	
CHEM	31A/B or X	Chemical Principles			4 or 8	
CHEM	33	Structure and Reactivity			4	
BIO or HUMBIO	41, 42 or 2A,3A,4A	Principles of Biology or Genetics, Evolution & Ecology/Cell & Dev Biology/The Human Organism			10 or 15	
<i>Science Unit Total (22 units minimum)</i>						
<i>(45 units min. Math/Sci combined)</i>						

Technology in Society Requirement (1 course required; see UGHB Figure 3-3 for approved list; see note 7)

--	--	--	--	--	--	--

Engineering Fundamentals (8 units minimum)

CS	106	Programming Methodology (B or X)			5	
		Elective (see note 2; CS 106A, B or X not allowed)				
<i>Engineering Fundamentals Total (8 units minimum)</i>						

NOTES

- * All courses listed on this form must be taken for a letter grade (if offered) and can be included in only one category.
 - * This printed form must be signed by the departmental representative. Changes must be petitioned (see UGHB pg 27-29) and initialed in
 - * Minimum Grade Point Average (GPA) for all courses in Engineering Fundamentals and Computer Science Depth (combined) is 2.0.
 - * Transfer and AP credits in Math, Science, Fundamentals, & TIS must be approved by the SoE Dean's Office. Transfer credits in Computer Science Depth must be approved by the Computer Science undergraduate program office.
 - * Courses must be taken for the number of units on the Program Sheet. CS103, 106B/X, 107, 109, 110, and 161 must be taken for 5 units.
- (1) Math 19, 20 and 21 may be taken instead of Math 41 and 42 as long as at least 23 math units are taken.
- (2) One course required; may not be CS 106A, B or X. See Engineering Fundamentals Fig. 3-4 in the UGHB for approved list.

CS BioC program sheet continues on page 2

CS Biocomputation Program Sheet cont.

CS Biocomputation Track Core and Depth (39 units minimum).

Dept	Course	Title	Transfer/Deviation Approval by Dept			Unit	Grade
			✓ if Transfer	Dept Initials	Date		
Core (15 units minimum)							
CS	107	Computer Organization and Systems				5	
CS	110	Principles of Computer Systems				5	
CS	161	Design and Analysis of Algorithms				5	
Depth (21 Units minimum)							
CS		One of: CS 121 or 221, 228, 229, 231A					
CS		One of: CS 262, 270, 173 or 273A, 274, 275, 278, 279					
CS		One of (if not selected above) CS 121 or 221, 228, 229, 231A 262, 270, 273A, 274, 275, 278, 279, 124, 145, 147, 148, 248					
		Restricted Elective (see note 3)					
		Restricted Elective (see note 4)					
		Restricted Elective (see note 5)					
		Restricted Elective (see note 6)					
Senior Project (1 course required)							
CS		At least 3 units of 191, 191W, 194, 194W, 210B, 294 or 294W (see note 7)				3	
<i>Computer Science Core and Depth Total 39 units minimum)</i>							

Program Approvals

Departmental

Printed Name: _____ Date: _____

Signature: _____

School of Engineering (No action required-office use only)

Printed Name: _____ Date: _____

Signature: _____

NOTES (continued from page 1)

- (3) One course selected from either the Biomedical Computation (BMC) 'Informatics' electives list (go to <http://bmc.stanford.edu> and select Informatics from the elective options), BioE 101, or from the general CS electives list: 108, 121 or 221*, 124, 131, 140, 142, 143, 144, 145, 147, 148, 149, 154, 155, 156, 157 (or PHIL 151), 164, 166, 167, 168, 190, 205A, 205B, 210A, 222, 223A, 224M, 224N, 224S, 224U, 224W, 225A, 225B, 227B, 228, 228T, 229, 229A, 229T, 231A, 231B, 231M, 232, 235, 240, 240H, 241, 242, 243, 244, 244B, 245, 246, 247, 248, 249A, 249B, 254, 255, 258, 261, 262, 263, 264, 265, 266, 267, 270, 271, 272, 173 or 273A, 274, 276, 277, 279, 295, 348B; CME 108; EE180, 282, 364A *(Students may not count both CS 121 and 221 toward their major requirements.)
- (4) One course selected from the BMC 'Informatics' electives list (go to <http://bmc.stanford.edu>).
- (5) One course selected from either the BMC 'Informatics', 'Cellular/Molecular', or 'Organs/Organisms' electives lists.
- (6) One course selected from either the BMC 'Cellular/Molecular' or 'Organs/Organisms' electives lists.
- (7) The WIM requirement may be met by taking CS 181W as a Technology in Society course or through the Senior Project course (191W, 194W, 210B, or 294W only).

Stanford University ♦ School of Engineering
Computer Science
Computer Engineering Track
2014-2015 Program Sheet

Final version of program sheet due to the department no later than one month prior to the last quarter of senior year.

Follow all requirements as stated for the year of the program sheet used.

Name: _____ SU ID #: _____
 Phone: _____ Email: _____
 Today's Date: _____ Month/Yr B.S. expected: _____

Mathematics and Science Requirement (*Delete courses and units not taken*)

Dept	Course	Title	Transfer/AP Approval by SoE			Unit	Grade
			✓ if Transfer	SoE Initials	Date		
Mathematics (26 units minimum)							
MATH	41	Calculus (see note 1)				5	
MATH	42	Calculus				5	
CS	103	Mathematical Foundations of Computing				5	
CS	109	Introduction to Probability for Computer Scientists				5	
<i>Plus two electives (see note 2)</i>							
<i>Mathematics Unit Total (26 units minimum)</i>							
Science 11 units minimum							
PHYS	41	Mechanics (or PHYS 21 or 61)				4	
PHYS	43	Electricity and Magnetism (or PHYS 23 or 63)				4	
		Elective (see note 3)					
<i>Science Unit Total (11 units minimum)</i>							
<i>(37 units min. Math/Sci combined)</i>							
Technology in Society Requirement (<i>1 course required; see UGHB Figure 3-3 for approved list; see note 8</i>)							
Engineering Fundamentals (13 units minimum)							
CS	106	Programming Abstractions (B or X)				5	
ENGR	40	Introductory Electronics (40A and 40M also allowed; see note 4)				5	
		Elective (See Fig. 3-4 in the UGHB for approved list; CS 106A, B or X not allowed)					
<i>Engineering Fundamentals Total (13 units minimum)</i>							

NOTES

- * **All courses listed on this form must be taken for a letter grade (if offered) and can be included under only one category.**
 - * This printed form must be signed by the departmental representative. Changes must be petitioned (see UGHB pg 27-29) and initialed in ink.
 - * Minimum Grade Point Average (GPA) for all courses in ENGR Fundamentals and CS Core, Depth, and Senior Project (combined) is 2.0.
 - * Transfer and AP credits in Math, Science, Fundamentals, & TIS must be approved by the SoE Dean's Office. Transfer credits in Computer Science Core, Depth and Senior Project must be approved by the Computer Science undergraduate program office.
 - * Courses must be taken for the number of units on the Program Sheet. CS103, 106B/X, 107, 109, 110, and 161 must be taken for 5 units.
- (1) Math 19, 20 and 21 may be taken instead of Math 41 and 42 as long as at least 26 math units are taken.
 - (2) Math electives: Math 51, 104, 108, 109, 110, 113; CS 157, 205A; PHIL 151; CME 100, 102, 104. Completion of Math 52 & 53 will (together) count as one Math elective. Restrictions: CS 157+ Phil 151 may not be used in combination to satisfy the Math electives requirement. Students who have taken both Math 51 and 52 may not count CME 100 as an elective.
 - (3) Any course of 3 or more units from the SoE Science List (Fig. 3-2 in the UGHB), PSYCH 30 or 55, or AP Chemistry may be used.
 - (4) Students who take ENGR 40A or 40M for fewer than 5 units are required to take 1-2 additional units of ENGR Fundamentals (13 units minimum), or 1-2 additional units of Depth (27 units minimum for track and elective courses).

Computer Engineering Track Core, Depth and Senior Project (47 units minimum)

Be advised: No course may be listed twice on the sheet; no double-counting.

Dept	Course	Title	Transfer/Deviation Approval by Dept			Unit	Grade	
			✓ if Transfer	Dept Initials	Date			
Core (15 units minimum)								
CS	107	Computer Organization and Systems				5		
CS	110	Principles of Computer Systems				5		
CS	161	Design and Analysis of Algorithms				5		
Depth; Track and Electives (29 units and 9 courses minimum)								
EE	108	Digital Systems I (Track Requirement A)						
EE	180	Digital Systems II (Track Requirement A)						
EE		Track Requirement B (see note 5)				4		
EE		Track Requirement B (see note 5)				4		
		Track Requirement C (see note 6)						
		Track Requirement C (see note 6)						
		Track Requirement C (see note 6)						
		Track Requirement C (see note 6)						
		Track Requirement C (see note 6)						
		Optional Elective						
Senior Project (1 course required)								
CS		At least 3 units of 191, 191W, 194, 194W, 210B, 294 or 294W (see note 7)				3		
<i>Computer Science Core, Depth and Senior Project Total (47 units minimum)</i>								

Program Approvals

Departmental

Printed Name: _____ Date: _____

Signature: _____

School of Engineering (No action required-office use only)

Printed Name: _____ Date: _____

Signature: _____

NOTES (continued from page 1)

- (5) Track Requirement B: Two courses selected from the following: EE 101A, 101B, 102A, 102B
- (6) Track Requirement C: Satisfy the requirements of one of the following concentrations:
 Digital Systems Concentration: CS 140 or 143; EE 109, 271;
 plus two of: CS140 or 143 (if not counted above), 144, 149, 240E, 244; EE 273, 282
 Robotics and Mechatronics Concentration: CS 205A, 223A; ME 210, ENGR 105
 plus one of: CS 225A, 225B, 231A, 235, 277; ENGR 205, 207A, 207B
 Networking Concentration: CS 140, 144
 plus three of: CS 240, 240E, 244, 244B, 244E, 249A, 249B; EE 179
- (7) The WIM requirement may be met by taking CS 181W as a Technology in Society course or through the Senior Project course (191W, 194W, 210B, or 294W only).

Stanford University ♦ School of Engineering
Computer Science
Graphics Track
2014-2015 Program Sheet

Final version of program sheet due to the department no later than one month prior to the last quarter of senior year.

Follow all requirements as stated for the year of the program sheet used.

Name: _____ SU ID #: _____
 Phone: _____ Email: _____
 Today's Date: _____ Month/Yr B.S. expected: _____

Mathematics and Science Requirement (*Delete courses and units not taken*)

Dept	Course	Title	Transfer/AP Approval by SoE			Unit	Grade
			✓ if Transfer	SoE Initials	Date		
Mathematics (26 units minimum)							
MATH	41	Calculus (see note 1)				5	
MATH	42	Calculus				5	
CS	103	Mathematical Foundations of Computing				5	
CS	109	Introduction to Probability for Computer Scientists				5	
<i>Plus two electives (see note 2)</i>							
<i>Mathematics Unit Total (26 units minimum)</i>							
Science 11 units minimum							
PHYSICS	41	Mechanics (or PHYS 21 or PHYS 61)				4	
PHYSICS	43	Electricity and Magnetism (or PHYS 23 or PHYS 63)				4	
		Elective (see note 3)					
<i>Science Unit Total (11 units minimum)</i>							
<i>(37 units min. Math/Sci combined)</i>							
Technology in Society Requirement (<i>1 course required; see UGHB Figure 3-3 for approved list; see note 10</i>)							
Engineering Fundamentals (13 units minimum)							
CS	106	Programming Abstractions (B or X)				5	
ENGR	40	Introductory Electronics (40A and 40M also allowed; see note 4)				5	
		Elective (See Fig. 3-4 in the UGHB for approved list; CS 106A, B or X not allowed)					
<i>Engineering Fundamentals Total (13 units minimum)</i>							

NOTES

- * **All courses listed on this form must be taken for a letter grade (if offered) and can be included under only one category.**
- * This printed form must be signed by the departmental representative. Changes must be petitioned (see UGHB pg 27-29) and initialed in ink
- * Minimum Grade Point Average (GPA) for all courses in Engineering Funds and CS Core, Depth, and Senior Project (combined) is 2.0.
- * Transfer and AP credits in Math, Science, Fundamentals, & TIS must be approved by the SoE Dean's Office. Transfer credits in Computer Science Core, Depth and Senior Project must be approved by the Computer Science undergraduate program office.
- * Courses must be taken for the number of units on the Program Sheet. CS103, 106B/X, 107, 109, 110, and 161 must be taken for 5 units.
- (1) Math 19, 20 and 21 may be taken instead of Math 41 and 42 as long as at least 26 math units are taken.
- (2) Math electives: Math 51, 104, 108, 109, 110, 113; CS 157, 205A; PHIL 151; CME 100, 102, 104. Completion of Math 52 & 53 will (together) count as one Math elective. Restrictions: CS 157+ Phil 151 may not be used in combination to satisfy the Math electives requirement. Students who have taken both Math 51 and 52 may not count CME 100 as an elective.
- (3) Any course of 3 or more units from the SoE Science List (Fig. 3-2 in the UGHB), Psych 30 or 55, or AP Chem may be used.
- (4) Students who take ENGR 40A or 40M for fewer than 5 units are required to take 1-2 additional units of ENGR Fundamentals (13 units minimum), or 1-2 additional units of Depth (27 units minimum for track and elective courses).

CS Graphics Track Core, Depth and Senior Project (43 units minimum)

Be advised: no course may be listed twice on this sheet; no double counting.

Dept	Course	Title	Transfer/Deviation Approval by Dept			Unit	Grade
			✓ if Transfer	Dept Initials	Date		
Core (15 units minimum)							
CS	107	Computer Organization and Systems				5	
CS	110	Principles of Computer Systems				5	
CS	161	Design and Analysis of Algorithms				5	
Depth; Track and Electives (25 units and seven courses minimum)							
CS	148	Introduction to Computer Graphics (Track Requirement A)				4	
CS	248	Three-Dimensional Computer Graphics (Track Requirement A)				4	
		Track Requirement B (see note 5)					
CS		Track Requirement C (see note 6)					
CS		Track Requirement C (see note 6)					
		Elective (see note 7)					
		Elective (see note 7)					
		Optional Elective (see note 8)					
Senior Project (1 course required)							
CS		At least 3 units of 191, 191W, 194, 194W, 210B, 294 or 294W (see note 9)				3	
<i>Computer Science Core, Depth and Senior Project Total (43 units minimum)</i>							

Program Approvals

Departmental

Printed Name: _____

Date: _____

Signature: _____

School of Engineering (No action required-office use only)

Printed Name: _____

Date: _____

Signature: _____

NOTES (continued from page 1)

- (5) Track Requirement B: Any one of CS 205A; CME 104, 108; MATH 52, 113. (CS 205A is strongly recommended as a preferred choice.) Note that students taking CME 104 are also required to take its prerequisite course, CME 102.)
- (6) Track Requirement C: Any two of CS 164, 178, 205B, 131 or 231A, 268, 348A, 348B, 448
- (7) Track Electives: At least two add'l courses selected from the Track Requirement B list, C list, General CS Electives list (see note 8), or the following: ARTSTUDI 160, 170, 179; CME 302, 306; EE 262, 264, 278, 368; ME 101; PSYCH 30, 221
- (8) General CS Electives: CS 108, 121 or 221*, 124, 131, 140, 142, 143, 144, 145, 147, 149, 154, 155, 156, 157 (or PHIL 151), 164, 166, 167, 168, 190, 205A, 205B, 210A, 222, 223A, 224M, 224N, 224S, 224U, 224W, 225A, 225B, 227B, 228, 228T, 229, 229A, 229T, 231A, 231B, 231M, 232, 235, 240, 240H, 241, 242, 243, 244, 244B, 245, 246, 247, 249A, 249B, 254, 255, 258, 261, 262, 263, 264, 265, 266, 267, 270, 271, 272, 173 or 273A, 274, 276, 277, 279, 295, 348B; CME 108; EE 180, 282, 364A
- (9) The WIM requirement may be met by taking CS 181W as a Technology in Society course or through the Senior Project course (191W, 194W, 210B, or 294W only).

*Students may not count both CS 121 and 221 toward their major requirements.

Stanford University ♦ School of Engineering
Computer Science
Human-Computer Interaction Track
2014-2015 Program Sheet

Final version of program sheet due to the department no later than one month prior to the last quarter of senior year.

Follow all requirements as stated for the year of the program sheet used.

Name: _____ SU ID #: _____
 Phone: _____ Email: _____
 Today's Date: _____ Month/Yr B.S. expected: _____

Mathematics and Science Requirement (*Delete courses and units not taken*)

Dept	Course	Title	Transfer/AP Approval by SoE			Unit	Grade
			✓ if Transfer	SoE Initials	Date		
Mathematics (26 units minimum)							
MATH	41	Calculus (see note 1)				5	
MATH	42	Calculus				5	
CS	103	Mathematical Foundations of Computing				5	
CS	109	Introduction to Probability for Computer Scientists				5	
<i>Plus two electives (see note 2)</i>							
			<i>Mathematics Unit Total (26 units minimum)</i>				
Science 11 units minimum							
PHYS	41	Mechanics (or PHYS 21 or 61)				4	
PHYS	43	Electricity and Magnetism (or PHYS 23 or 63)				4	
		Elective (see note 3)					
			<i>Science Unit Total (11 units minimum)</i>				
			<i>(37 units min. Math/Sci combined)</i>				
Technology in Society Requirement (<i>1 course required; see UGHB Figure 3-3 for approved list; see note 8</i>)							
Engineering Fundamentals (13 units minimum)							
CS	106	Programming Abstractions (B or X)				5	
ENGR	40	Introductory Electronics (40A and 40M also allowed; see note 4)				5	
		Elective (See Fig. 3-4 in the UGHB for approved list; CS 106A, B or X not allowed)					
			<i>Engineering Fundamentals Total (13 units minimum)</i>				

NOTES

- * **All courses listed on this form must be taken for a letter grade (if offered) and can be included under only one category.**
 - * This printed form must be signed by the departmental representative. Changes must be petitioned (see UGHB pg 27-29) and initialed in ink
 - * Minimum Grade Point Average (GPA) for all courses in Engineering Funds and CS Core, Depth, and Senior Project (combined) is 2.0.
 - * Transfer and AP credits in Math, Science, Fundamentals, & TIS must be approved by the SoE Dean's Office. Transfer credits in Computer Science Core, Depth and Senior Project must be approved by the Computer Science undergraduate program office.
 - * Courses must be taken for the number of units on the Program Sheet. CS103, 106B/X, 107, 109, 110, and 161 must be taken for 5 units.
- (1) Math 19, 20 and 21 may be taken instead of Math 41 and 42 as long as at least 26 math units are taken.
 - (2) The Mathematics electives list consists of: Math 51, 104, 108, 109, 110, 113; CS 157, 205A; Phil 151; CME 100, 102, 104. Completion of Math 52 & 53 will (together) count as one Math elective. Restrictions: CS 157 + Phil 151 may not be used in combination to satisfy the Math electives requirement. Students who have taken both Math 51 and 52 may not count CME 100 as an elective.
 - (3) Any course of 3 or more units from the SoE Science List (Fig. 3-2 in the UGHB), PSYCH 30 or 55, or AP Chemistry may be used.
 - (4) Students who take ENGR 40A or 40M for fewer than 5 units are required to take 1-2 additional units of ENGR Fundamentals (13 units minimum), or 1-2 additional units of Depth (27 units minimum for track and elective courses).

CS HCI Track Program Sheet (continued)

Human-Computer Interaction Track Core, Depth and Senior Project (43 units minimum)

Be advised: no course may be listed twice on the sheet. No double-counting.

Dept	Course	Title	Transfer/Deviation Approval by Dept			Unit	Grade	
			✓ if Transfer	Dept Initials	Date			
Core (15 units minimum)								
CS	107	Computer Organization and Systems				5		
CS	110	Principles of Computer Systems				5		
CS	161	Design and Analysis of Algorithms				5		
Depth; Track and Electives (25 units and seven courses minimum) see note 5								
CS	147	Introduction to HCI Design				4		
CS		One of: CS247, 377, 448B, 210A				4		
CS		Human: One of PSYCH 30, 45, 55, 70, 75, 131, 154, 252; ME 101, 116, or any MS&E 180-series						
CS		Computer: One of CS 108, 124, 140, 142, 221, 229, 229A, 249A						
		Interaction: One of CS 148, 376, 378, 447						
		Two additional courses from the lists above, general CS electives (see note 6), and ARTSTUD 160; COMM 169; CS476A; ME 115A, 115B; SYMSYS 245						
		Optional Elective						
Senior Project (1 course required)								
CS		At least 3 units of 191, 191W, 194, 194W, 210B, 294 or 294W (see note 7)				3		
<i>Computer Science Core, Depth and Senior Project Total (43 units minimum)</i>								

Program Approvals

Departmental

Printed Name: _____

Date: _____

Signature: _____

School of Engineering (No action required-office use only)

Printed Name: _____

Date: _____

Signature: _____

NOTES (continued from page 1)

- (5) Some HCI and Design project courses are limited enrollment and require students to submit applications. Students should be careful not to create a degree plan which only works if they get into a limited-enrollment course.
- (6) General CS Electives: CS 108, 121 or 221*, 124, 131, 140, 142, 143, 144, 145, 148, 149, 154, 155, 156, 157 or (PHIL 151), 164, 166, 167, 168, 190, 205A, 205B, 210A, 222, 223A, 224M, 224N, 224S, 224U, 224W, 225A, 225B, 227B, 228, 228T, 229, 229A, 229T, 231A, 231B, 231M, 232, 235, 240, 240H, 241, 242, 243, 244, 244B, 245, 246, 248, 249A, 249B, 254, 255, 258, 261, 262, 263, 264, 265, 266, 267, 270, 271, 272, 173 or 273A, 274, 276, 277, 279, 295, 348B; CME 108; EE180, 282, 364A.
- (7) The WIM requirement may be met by taking CS 181W as a Technology in Society course or through the Senior Project course (191W, 194W, 210B or 294W only).

*Students may not count both CS 121 and 221 toward their major requirements.

Stanford University ♦ School of Engineering
Computer Science
Individually Designed Track
2014-2015 Program Sheet

Final version of program sheet due to the department no later than one month prior to the last quarter of senior year.

Follow all requirements as stated for the year of the program sheet used.

Name: _____ SU ID #: _____
 Phone: _____ Email: _____
 Today's Date: _____ Month/Yr B.S. expected: _____

Mathematics and Science Requirement (*Delete courses and units not taken*)

Dept	Course	Title	Transfer/AP Approval by SoE			Unit	Grade
			✓ if Transfer	SoE Initials	Date		
Mathematics (26 units minimum)							
MATH	41	Calculus (see note 1)				5	
MATH	42	Calculus				5	
CS	103	Mathematical Foundations of Computing				5	
CS	109	Introduction to Probability for Computer Scientists				5	
<i>Plus two electives (see note 2)</i>							
<i>Mathematics Unit Total (26 units minimum)</i>							
Science 11 units minimum							
PHYS	41	Mechanics (or PHYS 21 or 61)				4	
PHYS	43	Electricity and Magnetism (or PHYS 23 or 63)				4	
		Elective (see note 3)				3 to 5	
<i>Science Unit Total (11 units minimum)</i>							
<i>(37 units min. Math/Sci combined)</i>							
Technology in Society Requirement (<i>1 course required; see UGHB Figure 3-3 for approved list; see note 7</i>)							
Engineering Fundamentals (13 units minimum)							
CS	106	Programming Abstractions (B or X)				5	
ENGR	40	Introductory Electronics (ENGR 40A and 40M also allowed; see note 4)				5	
		Elective (see note 5; neither CS 106A, B, and X, nor 2nd E40 class allowed)				3 to 5	
<i>Engineering Fundamentals Total (13 units minimum)</i>							

NOTES

- * **All courses listed on this form must be taken for a letter grade (if offered); and can be included under only one category.**
 - * This printed form must be signed by the departmental representative. Changes must be petitioned (see UGHB pg 27-29) and initialed in ink.
 - * Minimum Grade Point Average (GPA) for all courses in ENGR Fundamentals and CS Core, Depth, and Senior Project (combined) is 2.0.
 - * Transfer and AP credits in Math, Science, Fundamentals, & TIS must be approved by the SoE Dean's Office. Transfer credits in Computer Science Core, Depth and Senior Project must be approved by the Computer Science undergraduate program office.
 - * Courses must be taken for the number of units on the Program Sheet. CS103, 106B/X, 107, 109, 110, and 161 must be taken for 5 units.
- (1) Math 19, 20 and 21 may be taken instead of Math 41 and 42 as long as at least 26 math units are taken.
 - (2) Math electives: Math 51, 104, 108, 109, 110, 113; CS 157, 205A; PHIL 151; CME 100, 102, 104. Completion of Math 52 & 53 will (together) count as one Math elective. Restrictions: CS 157+ Phil 151 may not be used in combination to satisfy the Math electives requirement. Students who have taken both Math 51 and 52 may not count CME 100 as an elective.
 - (3) Any course of 3 or more units from the SoE Science List (Fig. 3-2 in the UGHB), PSYCH 30 or 55, or AP Chemistry may be used.
 - (4) Students who take ENGR 40A or 40M for fewer than 5 units are required to take 1-2 additional units of ENGR Fundamentals (13 units minimum), or 1-2 additional units of Depth (27 units minimum for track and elective courses).
 - (5) One course required; may not be CS 106A, B or X. See Engineering Fundamentals Fig. 3-4 in the UGHB for approved list.

CS Individually Designed Track Core, Depth and Senior Project (43 units minimum)

Be advised, no course may be listed twice on the sheet; no double-counting.

Dept	Course	Title	Transfer/Deviation Approval by Dept			Unit	Grade	
			✓ if Transfer	Dept Initials	Date			
Core (15 units minimum)								
CS	107	Computer Organization and Systems				5		
CS	110	Principles of Computer Systems				5		
CS	161	Design and Analysis of Algorithms				5		
Depth; Track and Electives (25 units and seven courses minimum) see note 6								
Senior Project (1 course required)								
CS		At least 3 units of 191, 191W, 194, 194W, 210B, 294 or 294W (see note 7)				3		
<i>Computer Science Core, Depth and Senior Project Total (43 units minimum)</i>								

Program Approvals

Undergraduate Advisor

Printed Name: _____ Date: _____

Signature: _____

Department

Printed Name: _____

Signature: _____

Date: _____

School of Engineering (No action required-office use only)

Printed Name: _____

Date: _____

Signature: _____

NOTES (continued from page 1)

- (6) Students may propose an Individually Designed Track. Proposals should include a minimum of seven courses, at least four of which must be CS courses numbered 100 or above. Proposals must be submitted & approved at least two quarters before graduation. To create an individually designed program, students should complete an *Individually Designed Track* program sheet and seek approval from their undergrad advisor and from the Associate Chair for Education, Prof. Mehran Sahami. Proposals will be evaluated for coherence and rigor. Approved program sheets should be given to the staff in the CS undergraduate program office. Any subsequent changes must go through the same proposal and approval process.
- (7) The WIM requirement may be met by taking CS 181W as a Technology in Society course or through the Senior Project course (191W, 194W, 210B, or 294W only).

Stanford University ♦ School of Engineering
Computer Science
Information Track
2014-2015 Program Sheet

Final version of program sheet due to the department no later than one month prior to the last quarter of senior year.

Follow all requirements as stated for the year of the program sheet used.

Name: _____ SU ID #: _____
 Phone: _____ Email: _____
 Today's Date: _____ Month/Yr B.S. expected: _____

Mathematics and Science Requirement (*Delete courses and units not taken*)

Dept	Course	Title	Transfer/AP Approval by SoE			Unit	Grade
			✓ if Transfer	SoE Initials	Date		
Mathematics (26 units minimum)							
MATH	41	Calculus (see note 1)				5	
MATH	42	Calculus				5	
CS	103	Mathematical Foundations of Computing				5	
CS	109	Introduction to Probability for Computer Scientists				5	
<i>Plus two electives (see note 2)</i>							
<i>Mathematics Unit Total (26 units minimum)</i>							
Science 11 units minimum							
PHYS	41	Mechanics (or PHYS 21 or 61)				4	
PHYS	43	Electricity and Magnetism (or PHYS 23 or 63)				4	
		Elective (see note 3)					
<i>Science Unit Total (11 units minimum)</i>							
<i>(37 units min. Math/Sci combined)</i>							
Technology in Society Requirement (<i>1 course required; see UGHB Figure 3-3 for approved list; see note 9</i>)							
Engineering Fundamentals (13 units minimum)							
CS	106	Programming Abstractions (B or X)				5	
ENGR	40	Introductory Electronics (40A and 40M also allowed; see note 4)				5	
		Elective (see note 5; CS 106A, B, and X not allowed)					
<i>Engineering Fundamentals Total (13 units minimum)</i>							

NOTES

- * **All courses listed on this form must be taken for a letter grade (if offered), and can be included under only one category.**
 - * The printed form must be signed by the departmental representative. Changes must be petitioned (see UGHB pg 27-29) and initialed in ink.
 - * Minimum Grade Point Average (GPA) for all courses in ENGR Fundamentals and CS Core, Depth, and Senior Project (combined) is 2.0.
 - * Transfer and AP credits in Math, Science, Fundamentals, & TIS must be approved by the SoE Dean's Office. Transfer credits in Computer Science Core, Depth and Senior Project must be approved by the Computer Science undergraduate program office.
 - * Courses must be taken for the number of units on the Program Sheet. CS103, 106B/X, 107, 109, 110, and 161 must be taken for 5 units.
- (1) Math 19, 20 and 21 may be taken instead of Math 41 and 42 as long as at least 26 math units are taken.
 - (2) Math electives: Math 51, 104, 108, 109, 110, 113; CS 157, 205A; PHIL 151; CME 100, 102, 104. Completion of Math 52 & 53 will (together) count as one Math elective. Restrictions: CS 157+ Phil 151 may not be used in combination to satisfy the Math electives req't. Students who have taken both Math 51 & 52 may not count CME 100 as an elective.
 - (3) Any course of 3 or more units from the SoE Science List (Fig. 3-2 in the UGHB), PSYCH 30 or 55, or AP Chemistry may be used.
 - (4) Students who take ENGR 40A or 40M for fewer than 5 units are required to take 1-2 additional units of ENGR Fundamentals (13 units minimum), or 1-2 additional units of Depth (27 units minimum for track and elective courses).
 - (5) One course required; may not be CS 106A, B or X. See Engineering Fundamentals Chap 3, Fig. 3-4 in the UGHB for approved list.

CS Information Track Core, Depth and Senior Project (43 units minimum)

Be advised, no course may be listed twice on the sheet; no double-counting.

Dept	Course	Title	Transfer/Deviation Approval by Dept			Unit	Grade
			✓ if Transfer	Dept Initials	Date		
Core (15 units minimum)							
CS	107	Computer Organization and Systems				5	
CS	110	Principles of Computer Systems				5	
CS	161	Design and Analysis of Algorithms				5	
Depth; Track and Electives (25 units and seven courses minimum)							
CS	124	From Languages to Information (Track Requirement A)				4	
CS	145	Introduction to Databases (Track Requirement A)				4	
CS		Track Requirement B (see note 6)					
CS		Track Requirement B (see note 6)					
		Elective (see note 7)					
		Elective (see note 7)					
		Elective (see note 7)					
		Optional Elective					
Senior Project (1 course required)							
CS		At least 3 units of 191, 191W, 194, 194W, 294 or 294W (see note 9)				3	
<i>Computer Science Core, Depth and Senior Project Total (43 units minimum)</i>							

Program Approvals

Departmental

Printed Name: _____

Date: _____

Signature: _____

School of Engineering (No action required-office use only)

Printed Name: _____

Date: _____

Signature: _____

NOTES (continued from page 1)

- (6) Track Requirement B: Two courses, each from a different area: Area I) Information-based AI applications [CS 224N, 224S, 229, 229A]; Area II) Database and Information Systems [CS 140, 142, 245, 246, 341, 345, 346, 347]; Area III) Information Systems in Biology [CS 262, 270, 274]; Area IV) Information Systems on the Web [CS 224W, 276, 364B]
- (7) Track Electives: At least three additional courses selected from the Track Requirement B list, or the General CS Electives list (see note 8).
- (8) General CS Electives: CS 108, 121 or 221*, 131, 140, 142, 143, 144, 147, 148, 149, 154, 155, 156, 157 (or PHIL 151), 164, 166, 167, 168, 190, 205A, 205B, 210A, 222, 223A, 224M, 224N, 224S, 224U, 224W, 225A, 225B, 227B, 228, 228T, 229, 229A, 229T, 231A, 231B, 231M, 232, 235, 240, 240H, 241, 242, 243, 244, 244B, 245, 246, 247, 248, 249A, 249B, 254, 255, 258, 261, 262, 263, 264, 265, 266, 267, 270, 271, 272, 173 or 273A, 274, 276, 277, 279, 295, 348B; CME 108; EE 180, 282, 364A
- (9) The WIM requirement may be met by taking CS 181W as a Technology in Society course or through the Senior Project course (191W, 194W, 210B, or 294W only).

*Students may not count both CS 121 and 221 toward their major requirements.

Stanford University ♦ School of Engineering
Computer Science
Systems Track
2014-2015 Program Sheet

Final version of program sheet due to the department no later than one month prior to the last quarter of senior year.

Follow all requirements as stated for the year of the program sheet used.

Name: _____ SU ID #: _____
 Phone: _____ Email: _____
 Today's Date: _____ Month/Yr B.S. expected: _____

Mathematics and Science Requirement (*Delete courses and units not taken*)

Dept	Course	Title	Transfer/AP Approval by SoE			Unit	Grade
			✓ if Transfer	SoE Initials	Date		
Mathematics (26 units minimum)							
MATH	41	Calculus (see note 1)				5	
MATH	42	Calculus				5	
CS	103	Mathematical Foundations of Computing				5	
CS	109	Introduction to Probability for Computer Scientists				5	
<i>Plus two electives (see note 2)</i>							
<i>Mathematics Unit Total (26 units minimum)</i>							
Science 11 units minimum							
PHYSICS	41	Mechanics (or PHYSICS 21 or 61)				4	
PHYSICS	43	Electricity and Magnetism (or PHYSICS 23 or 63)				4	
		Elective (see note 3)					
<i>Science Unit Total (11 units minimum)</i>							
<i>(37 units min. Math/Sci combined)</i>							
Technology in Society Requirement (<i>1 course required; see UGHB Figure 3-3 for approved list; see note 9</i>)							
Engineering Fundamentals (13 units minimum)							
CS	106	Programming Abstractions (B or X)				5	
ENGR	40	Introductory Electronics (40A and 40M also allowed; see note 4)				5	
		Elective (see note 5; CS 106A, B or X not allowed)					
<i>Engineering Fundamentals Total (13 units minimum)</i>							

NOTES

- * **All courses listed on this form must be taken for a letter grade (if offered) and can be included under only one category.**
- * This printed form must be signed by the departmental representative. Changes must be petitioned (see UGHB pg 27-29) and initialed in ink.
- * Minimum Grade Point Average (GPA) for all courses in ENGR Fundamentals and CS Core, Depth, and Senior Project (combined) is 2.0.
- * Transfer and AP credits in Math, Science, Fundamentals, & TIS must be approved by the SoE Dean's Office. Transfer credits in Computer Science Core, Depth and Senior Project must be approved by the Computer Science undergraduate program office.
- * Courses must be taken for the number of units on the Program Sheet. CS103, 106B/X, 107, 109, 110, and 161 must be taken for 5 units.
- (1) Math 19, 20 and 21 may be taken instead of Math 41 and 42 as long as at least 26 math units are taken.
- (2) Math electives: Math 51, 104, 108, 109, 110, 113; CS 157, 205A; PHIL 151; CME 100, 102, 104. Completion of Math 52 & 53 will (together) count as one Math elective. Restrictions: CS 157+ Phil 151 may not be used in combination to satisfy the Math electives requirement. Students who have taken both Math 51 & 52 may not count CME 100 as an elective.
- (3) Any course of 3 or more units from the SoE Science List (Fig. 3-2 in the UGHB), PSYCH 30 or 55, or AP Chemistry may be used.
- (4) Students who take ENGR 40A or 40M for fewer than 5 units are required to take 1-2 additional units of ENGR Fundamentals (13 units minimum), or 1-2 additional units of Depth (27 units minimum for track and elective courses).
- (5) One course required; may not be CS 106A, B or X. See Engineering Fundamentals Chap 3, Fig. 3-4 in the UGHB for approved list.

CS Systems Program Sheet (continued)

Systems Track Core, Depth and Senior Project (43 units minimum) Be advised, no course may be listed twice on the sheet; no double-counting.

Dept	Course	Title	Transfer/Deviation Approval by Dept			Unit	Grade
			✓ if Transfer	Dept Initials	Date		
Core (15 units minimum)							
CS	107	Computer Organization and Systems				5	
CS	110	Principlets of Computer Systems				5	
CS	161	Design and Analysis of Algorithms				5	
Depth; Track and Electives (25 units and seven courses minimum)							
CS	140	Operating Sys and Systems Program (Track Requirement A)				4	
		One of: CS 143, EE 180 (Track Requirement B)					
CS		Track Requirement C (see note 6)					
CS		Track Requirement C (see note 6)					
		Elective (see note 7)					
		Elective (see note 7)					
		Elective (see note 7)					
		Optional Elective					
Senior Project (1 course required)							
CS		At least 3 units of 191, 191W, 194, 194W, 210B, 294 or 294W (see note 9)				3	
<i>Computer Science Core, Depth and Senior Project Total (43 units minimum)</i>							

Program Approvals

Departmental

Printed Name: _____

Date: _____

Signature: _____

School of Engineering (No action required-office use only)

Printed Name: _____

Date: _____

Signature: _____

NOTES (continued from page 1)

- (6) Track Requirement C: Two courses selected from the Track Requirement B list or the following: CS 144, 145, 149, 155, 240, 242, 243, 244, 245; EE 271, 282
- (7) Track Electives: At least 3 additional courses selected from the Track Requirement C list, the General CS Electives list (see note 8), or the following - CS 240E, 244C, 244E, 315A or 316, 315B, 341, 343, 344, 344E, 345, 346, 347, 349 (with permission of undergraduate advisor), CS 448; EE 382C, 384A, 384B, 384C, 384S, 384X
- (8) General CS Electives: CS 108, 121 or 221*, 124, 131, 142, 143, 144, 145, 147, 148, 149, 154, 155, 156, 157 or Phil 151, 164, 166, 167, 168, 190, 205A, 205B, 210A, 222, 223A, 224M, 224N, 224S, 224U, 224W, 225A, 225B, 227B, 228, 228T, 229, 229A, 229T, 231A, 231B, 231M, 232, 235, 240, 240H, 241, 242, 243, 244, 244B, 245, 246, 247, 248, 249A, 249B, 254, 255, 258, 261, 262, 263, 264, 265, 266, 267, 270, 271, 272, 173 or 273A, 274, 276, 277, 279, 295, 348B; CME 108; EE 180, 282, 364A
- (9) The WIM requirement may be met by taking CS 181W as a Technology in Society course or through the Senior Project course (191W, 194W, 210B, or 294W only).

*Students may not count both CS 121 and 221 toward their major requirements.

Stanford University ♦ School of Engineering
Computer Science
Theory Track
2014-2015 Program Sheet

Final version of program sheet due to the department no later than one month prior to the last quarter of senior year.

Follow all requirements as stated for the year of the program sheet used.

Name: _____ SU ID #: _____
 Phone: _____ Email: _____
 Today's Date: _____ Month/Yr B.S. expected: _____

Mathematics and Science Requirement (*Delete courses and units not taken*)

Dept	Course	Title	Transfer/AP Approval by SoE			Unit	Grade
			✓ if Transfer	SoE Initials	Date		
Mathematics (26 units minimum)							
MATH	41	Calculus (see note 1)				5	
MATH	42	Calculus				5	
CS	103	Mathematical Foundations of Computing				5	
CS	109	Introduction to Probability for Computer Scientists				5	
<i>Plus two electives (see note 2)</i>							
<i>Mathematics Unit Total (26 units minimum)</i>							
Science 11 units minimum							
PHYSICS	41	Mechanics (or PHYSICS 21 or PHYSICS 61)				4	
PHYSICS	43	Electricity and Magnetism (or PHYSICS 23 or PHYSICS 63)				4	
		Elective (see note 3)					
<i>Science Unit Total (11 units minimum)</i>							
<i>(37 units min. Math/Sci combined)</i>							
Technology in Society Requirement (<i>1 course required; see UGHB Figure 3-3 for approved list; see note 10</i>)							
Engineering Fundamentals (13 units minimum)							
CS	106	Programming Abstractions (B or X)				5	
ENGR	40	Introductory Electronics (40A and 40M also allowed; see note 4)				5	
		Elective (see note 5; CS 106A, B or X not allowed)					
<i>Engineering Fundamentals Total (13 units minimum)</i>							

NOTES

- * **All courses listed on this form must be taken for a letter grade (if offered) and can be included under only one category.**
- * This printed form must be signed by the departmental representative. Changes must be petitioned (see UGHB pg 27-29) and initialed in ink.
- * Minimum Grade Point Average (GPA) for all courses in ENGR Fundamentals and CS Core, Depth, and Senior Project (combined) is 2.0.
- * Transfer and AP credits in Math, Science, Fundamentals, & TIS must be approved by the SoE Dean's Office. Transfer credits in Computer Science Core, Depth and Senior Project must be approved by the Computer Science undergraduate program office.
- * Courses must be taken for the number of units on the Program Sheet. CS103, 106B/X, 107, 109, 110, and 161 must be taken for 5 units.
- (1) Math 19, 20 and 21 may be taken instead of Math 41 and 42 as long as at least 26 math units are taken.
- (2) Math electives: Math 51, 104, 108, 109, 110, 113; CS 157, 205A; PHIL 151; CME 100, 102, 104. Completion of Math 52 & 53 will (together) count as one Math elective. Restrictions: CS 157+ Phil 151 may not be used in combination to satisfy the Math electives requirement. Students who have taken both Math 51 & 52 may not count CME 100 as an elective.
- (3) Any course of 3 or more units from the SoE Science List (Fig. 3-2 in the UGHB), PSYCH 30 or 55, or AP Chemistry may be used.
- (4) Students who take ENGR 40A or 40M for fewer than 5 units are required to take 1-2 additional units of ENGR Fundamentals (13 units minimum), or 1-2 additional units of Depth (27 units minimum for track and elective courses).
- (5) One course required; may not be CS 106A, B or X. See Engineering Fundamentals Fig. 3-4 in the UGHB for approved list.

CS Theory Track Program Sheet (continued)

Theory Track Core, Depth and Senior Project (43 units minimum)

Be advised: no course may be listed twice on the sheet; no double-counting.

Dept	Course	Title	Transfer/Deviation Approval by Dept			Unit	Grade
			✓ if Transfer	Dept Initials	Date		
Core (15 units minimum)							
CS	107	Computer Organization and Systems				5	
CS	110	Principles of Computer Systems				5	
CS	161	Design and Analysis of Algorithms				5	
Depth; Track and Electives (25 units and seven courses minimum)							
CS	154	Intro Automata and Complexity Theory (Track Requirement A)				4	
CS		Track Requirement B (see note 6)				3	
		Track Requirement C (see note 7)					
		Track Requirement C (see note 7)					
		Elective (see note 8)					
		Elective (see note 8)					
		Elective (see note 8)					
		Optional Elective					
Senior Project (1 course required)							
CS		At least 3 units of 191, 191W, 194, 194W, 210B, 294 or 294W (see note 10)				3	
<i>Computer Science Core, Depth and Senior Project Total (43 units minimum)</i>							

Program Approvals

Departmental

Printed Name: _____

Date: _____

Signature: _____

School of Engineering (No action required-office use only)

Printed Name: _____

Date: _____

Signature: _____

NOTES (continued from page 1)

- (6) Track Requirement B: Any one of CS 164, 167, 168, 255, 258, 261, 264, 265, 268, 361A, 361B
- (7) Track Requirement C: Two courses selected from the Track Requirement B list or the following - CS 143, 155, 157 (or PHIL 151), 166, 205A, 228, 242, 254, 259 (with permission of undergraduate advisor), 262, 266, 267, 354, 355, 357, 358, 359 (with permission of undergraduate advisor), 364A, 364B, 366, 367, 369 (with permission of undergraduate advisor), 374; MS&E 310
- (8) Track Electives: At least three additional courses selected from the Track Requirement B list, the Track Requirement C list, the General CS Electives list (see note 9), or the following - CME 302, 305; Phil 152
- (9) General CS Electives: CS 108, 121 or 221*, 124, 131, 140, 142, 143, 144, 145, 147, 148, 149, 155, 156, 157 or Phil 151, 164, 166, 167, 168, 190, 205A, 205B, 210A, 222, 223A, 224M, 224N, 224S, 224U, 224W, 225A, 225B, 227B, 228, 228T, 229, 229A, 229T, 231A, 231B, 231M, 232, 235, 240, 240H, 241, 242, 243, 244, 244B, 245, 246, 247, 248, 249A, 249B, 254, 255, 258, 261, 262, 263, 264, 265, 266, 267, 270, 271, 272, 173 or 273A, 274, 276, 277, 279, 295, 348B; CME 108; EE 180, 282, 364A
- (10) The WIM req't may be met by taking CS 181W as a TiS course or through the Senior Project course (191W, 194W, 210B, or 294W only).

*Students may not count both CS 121 and 221 toward their major requirements.

Stanford University ♦ School of Engineering
Computer Science
Unspecialized Track
2014-2015 Program Sheet

Final version of program sheet due to the department no later than one month prior to the last quarter of senior year.

Follow all requirements as stated for the year of the program sheet used.

Name: _____ SU ID #: _____
 Phone: _____ Email: _____
 Today's Date: _____ Month/Yr B.S. expected: _____

Mathematics and Science Requirement (*Delete courses and units not taken*)

Dept	Course	Title	Transfer/AP Approval by SoE			Unit	Grade
			✓ if Transfer	SoE Initials	Date		
Mathematics (26 units minimum)							
MATH	41	Calculus (see note 1)				5	
MATH	42	Calculus				5	
CS	103	Mathematical Foundations of Computing				5	
CS	109	Introduction to Probability for Computer Scientists				5	
<i>Plus two electives (see note 2)</i>							
<i>Mathematics Unit Total (26 units minimum)</i>							
Science 11 units minimum							
PHYS	41	Mechanics (or PHYSICS 21 or PHYSICS 61)				4	
PHYS	43	Electricity and Magnetism (or PHYSICS 23 or PHYSICS 63)				4	
		Elective (see note 3)					
<i>Science Unit Total (11 units minimum)</i>							
<i>(37 units min. Math/Sci combined)</i>							
Technology in Society Requirement (<i>1 course required; see UGHB Figure 3-3 for approved list; see note 10</i>)							
Engineering Fundamentals (13 units minimum)							
CS	106	Programming Abstractions (B or X)				5	
ENGR	40	Introductory Electronics (ENGR 40A and 40M also allowed; see note 4)				5	
		Fundamentals Elective (CS 106A, B or X not allowed)					
<i>Engineering Fundamentals Total (13 units minimum)</i>							

NOTES

- * **All courses listed on this form must be taken for a letter grade (if offered) and can be included under only one category.**
- * This printed form must be signed by the departmental representative. Changes must be petitioned (see UGHB pg 27-29) and initialed in ink.
- * Minimum Grade Point Average (GPA) for all courses in ENGR Fundamentals and CS Core, Depth, and Senior Project (combined) is 2.0.
- * Transfer and AP credits in Math, Science, Fundamentals, & TIS must be approved by the SoE Dean's Office. Transfer credits in Computer Science Core, Depth and Senior Project must be approved by the Computer Science undergraduate program office.
- * Courses must be taken for the number of units on the Program Sheet. CS103, 106B/X, 107, 109, 110, and 161 must be taken for 5 units.
- (1) Math 19, 20 and 21 may be taken instead of Math 41 and 42 as long as at least 26 math units are taken.
- (2) Math electives: Math 51, 104, 108, 109, 110, 113; CS 157, 205A; PHIL 151; CME 100, 102, 104. Completion of Math 52 & 53 will (together) count as one Math elective. Restrictions: CS 157+ Phil 151 may not be used in combination to satisfy the Math electives requirement. Students who have taken both Math 51 & 52 may not count CME 100 as an elective.
- (3) Any course of 3 or more units from the SoE Science List (Fig. 3-2 in the UGHB), PSYCH 30 or 55, or AP Chemistry may be used.
- (4) Students who take ENGR 40A or 40M for fewer than 5 units are required to take 1-2 additional units of ENGR Fundamentals (13 units minimum), or 1-2 additional units of Depth (27 units minimum for track and elective courses).
- (5) One course required; may not be CS 106A, B or X. See Engineering Fundamentals Fig. 3-4 in the UGHB for approved list.

CS Unspecialized Track Program Sheet (continued)

Unspecialized Track Core, Depth and Senior Project (43 units minimum)

Be advised, no course may be listed twice on the sheet; no double-counting.

Dept	Course	Title	Transfer/Deviation Approval by Dept			Unit	Grade
			✓ if Transfer	Dept Initials	Date		
Core (15 units minimum)							
CS	107	Computer Organization and Systems				5	
CS	110	Principles of Computer Systems				5	
CS	161	Design and Analysis of Algorithms				5	
Depth; Track and Electives (25 units and seven courses minimum)							
CS	154	Intro Automata and Complexity Theory (Track Requirement A)				4	
CS		One of CS 140, 143 (Track Requirement B)				4	
		Track Requirement C (see note 6)					
CS		Track Requirement D (see note 7)					
CS		Track Requirement E (see note 8)					
		Elective (see note 9)					
		Elective (see note 9)					
		Optional Elective (see note 9)					
Senior Project (1 course required)							
CS		At least 3 units of 191, 191W, 194, 194W, 210B, 294 or 294W (see note 10)				3	
<i>Computer Science Core, Depth and Senior Project Total (43 units minimum)</i>							

Program Approvals

Departmental

Printed Name: _____ Date: _____

Signature: _____

School of Engineering (No action required-office use only)

Printed Name: _____ Date: _____

Signature: _____

NOTES (continued from page 1)

- (6) Track Requirement C: One additional course from the Track Requirement B list or the following: CS 144, 155, 242, 244; EE 180
- (7) Track Requirement D: Any one of CS 121 or 221, 223A, 228, 229, 231A
- (8) Track Requirement E: Any one of CS 145, 147, 148, 248, 262
- (9) At least two courses from the General CS Electives list: CS 108, 121 or 221*, 124, 131, 140, 142, 143, 144, 145, 147, 148, 149, 155, 156, 157 (or PHIL 151), 164, 166, 167, 168, 190, 205A, 205B, 210A, 222, 223A, 224M, 224N, 224S, 224U, 224W, 225A, 225B, 227B, 228, 228T, 229, 229A, 229T, 231A, 231B, 231M, 232, 235, 240, 240H, 241, 242, 243, 244, 244B, 245, 246, 247, 248, 249A, 249B, 254, 255, 258, 261, 262, 263, 264, 265, 266, 267, 270, 271, 272, 173 or 273A, 274, 276, 277, 279, 295, 348B; CME 108; EE 180, 282, 364A
*(Students may not count both CS 121 and 221 toward their major requirements.)
- (10) The WIM req't may be met by taking CS 181W as a TiS course or through the Senior Project course (191W, 194W, 210B, or 294W only).

ELECTRICAL ENGINEERING

The mission of the Department of Electrical Engineering is to augment the liberal education expected of all Stanford undergraduates, to impart a basic understanding of electrical engineering built on a foundation of physical science, mathematics, computing, and technology, and to provide majors in the department with knowledge of electrical engineering principles along with the required supporting knowledge of mathematics, science, computing, and engineering fundamentals. The program develops students' skills in performing and designing experimental projects and communicating their findings to the scientific community effectively. Students in the major are required to select one sub-discipline for specialization. Choices include bio-electronics and bio-imaging, circuits and devices, computer hardware, computer software, music, signal processing, communication and controls, photonics, solid state and electromagnetics, and energy and environment. The program prepares students for careers in government agencies, the corporate sector, or for future study in graduate or professional schools. The educational objectives and student outcomes for the Department of Electrical Engineering are shown in the table on the last page.

The major in Electrical Engineering builds on foundations in math and physics. It prepares students for a broad set of career opportunities in information, systems and physical electronic technology and applied science. Electrical Engineering is where the physical world and the virtual world connect. This is a world created from sensors, computing, communications and information. Innovations in Electrical Engineering have fundamentally transformed all aspects of our lives. Some of these are: electrical power generation and transmission, wired and wireless communications, integrated electronics, digital computers, healthcare technology (MRI, ultrasound, implantable devices), cellular phones, and the internet. All of these technologies and innovations have solid roots in the sciences and engineering that are integral to the study of Electrical Engineering.

The Departmental requirements for a BS degree in Electrical Engineering include a core set of courses required of every major and a set of specialty areas from which one sequence must be chosen. Each program of study is also expected to include physics as part of science, and calculus, linear algebra, and ordinary differential equations as part of mathematics. The math requirement also includes a course in basic probability and statistics (total of 40 units minimum required). Specific math and science requirements for EEs are listed below. Other program requirements detailed below include Technology in Society (one course) and one and one half years of

Engineering Topics (60 minimum required), which include Engineering Fundamentals and Depth, which in turn includes a selection of electrical engineering core courses, a specialty sequence, electrical engineering electives, and a design course from an approved list. To be considered electrical engineering courses, courses must either be listed in the Stanford Bulletin as EE courses or as EE Related courses (courses considered by the Department of EE to be programmatically equivalent to EE courses). The design course is intended to culminate the substantial design experience distributed throughout the curriculum. Students are required to pass a writing-intensive course (WIM) within their major (those who double-major will have to take two WIM courses).

Students are required to have a program planning sheet approved by their advisor and the department prior to the end of the quarter following the quarter they declare their major and at least one year prior to graduation. Programs may be changed at anytime (except during the final quarter before graduation) by submitting a new approved program sheet. Program sheets for the general EE requirements and for each of the EE specialty sequences may be found at <http://ughb.stanford.edu>.

To place the requirements in context, sample programs of study are given which satisfy all requirements for the BS degree in EE. Students with advanced placement will have greater freedom in course selection than is shown in the program examples. Those considering studying at one of the foreign centers should consult the Bing Overseas Studies Program office as soon as possible, for this will add constraints in program planning. All students are expected to consult their faculty advisor, are encouraged to consult the Electrical Engineering Student Advisor in Packard 110; phone: (650) 725-3799, email: undergradta@ee.stanford.edu, and may find it useful to consult other students when designing their program.

For updated information, visit the EE website at: <http://ee.stanford.edu/>

REQUIREMENTS

Math and Science Requirements:

It is a School of Engineering requirement that all courses counting toward the major must be taken for a letter grade if the instructor offers that option. Students with multiple degrees should be aware that math, science, and fundamentals courses can be used to fulfill breadth requirements for more than one degree program, but a depth course can be counted toward only one major or minor program; any course can be double-counted in a secondary major.

EE Mathematics & Science: Minimum 40 units Math & Science combined, including the following requirements:

MATHEMATICS

Course	Title	Units
MATH 41+42	Calculus	10
Select one 2-course sequence. The MATH courses are more theoretical, while the CME courses are applied and build on programming and use of tools like MATLAB.		
CME 100/ENGR 154 and CME 102/CME 155A OR	Vector Calculus for Engineers and Ordinary Differential Equations for Engineers	5 5
MATH 52 and MATH 53	Integral Calculus of Several Variables and Ordinary Differential Equations with Linear Algebra	5 5
Select one additional 100-level Math course:		
EE 102B (if not used in Depth)	Signal Processing and Linear Systems II	4
CME 103/EE 103	Introduction to Matrix Methods	3
EE 142	Engineering Electromagnetics	3
CME 104/ENGR 155B	Linear Algebra and Partial Differential Equations for Engineers	5
MATH 113	Linear Algebra and Matrix Theory	3
CS 103	Mathematical Foundations of Computing	3-5
Statistics/Probability: Select one: Choosing a statistics options depends upon your interest and preferences. The EE option below has a theoretical perspective; the CS option is more application-oriented. Note: CME 106 or STATS 116 can also fulfill this requirement, but are not preferred.		
EE 178 or	Probabilistic Systems Analysis or	4
CS 109	Introduction to Probability for Computer Scientists	5

SCIENCE (12 UNITS MINIMUM)

Course	Title	Units
PHYSICS 41 and PHYSICS 43*	Mechanics and Electricity & Magnetism	4 4
or		
PHYSICS 61 and PHYSICS 63	Mechanics and Special Relativity and Electricity, Magnetism and Waves	4 4
* The EE introductory class ENGR 40 or 40 M may be taken concurrently with PHYSICS 43; many students find the material complimentary in terms of fundamental and applied perspectives on electronics.		
One additional 4-5 unit science course from Approved List in UGHB, Figure 3-2		

TECHNOLOGY IN SOCIETY (ONE COURSE FROM SOE-APPROVED LIST FIG.3-3; 3-5 UNITS)

Engineering Topics: Minimum of 60 units Fundamentals & Depth

ENGINEERING FUNDAMENTALS: 3 COURSES

Select one of the following:		
CS 106B/ENGR 70B Or CS 106X/ENGR 70X	Programming Abstractions or Programming Abstractions (Accelerated)	5 5
Plus two additional courses, at least one of which is not in EE or CS (CS 106A is not allowed). Choose from approved list in Chapter 3, Fig. 3-4. Recommended: one from ENGR 40, ENGR 40M, or ENGR 40P		8-10

ENGINEERING CORE AND DEPTH ELECTIVES:

WRITING IN THE MAJOR (WIM) (ONE COURSE)

Course	Title	Units
EE 109	Digital Systems Design Lab	4
EE 133	Analog Communications Design Laboratory	4
EE 134	Introduction to Photonics	4
EE 152	Green Electronics	4
EE 153	Power Electronics	4
EE 168	Introduction to Digital Image Processing (Not given 2014-15)	4
EE 191W	Special Studies and Reports in Electrical Engineering (WIM; Dept approval required) May satisfy WIM only if taken as a follow-up to an REU or independent study project or as part of an Honors thesis project where a faculty agrees to provide supervision of writing a technical paper and with suitable support from the Writing Center.	3-4
CS 194W	Software Project	3

CORE COURSES

EE 100	The Electrical Engineering Profession	1
EE 101A	Circuits	4
EE 102A	Signal Processing and Linear Systems I	4
EE 108	Digital Systems Design	4
Physics in Electrical Engineering - select one of the following courses:		
EE 41/ENGR 40P*	Physics of Electrical Engineering* (not offered 2014-15)	5
EE 65	Modern Physics for Engineers (preferred)	3
EE 142**	Engineering Electromagnetics	3

*Note: EE 41/ENGR 40P cannot be used for both Physics in EE and to fulfill the Engineering Fundamentals requirement.

**Note: EE 142 cannot be used for both Physics in EE and as a Depth Elective.

DEPTH COURSES (14 UNITS)

Select 4 courses from one specialty area: 1 Required course, 1 Design course; 2 Electives

BIO-ELECTRONICS AND BIO-IMAGING

This specialty area provides opportunities to study topics ranging from neuro-biology and electronic-bio-interfaces to systems and signal processing for medical imaging. One course must be a design project, either: EE 134 or EE 168. For this sequence taking the EE 101 or EE 102 core first is preferable; for the EE 134 course, more physics background and interest is typically required.

Required Course:		
EE 101B or EE 102B	Circuits II or Signal Processing and Linear Systems II	4 4
Design Course:		
EE 134 (WIM) or EE 168 (WIM)	Introduction to Photonics or Introduction to Digital Image Processing	4 4
Electives (choose two electives from below or from above two boxes for a total of 4 courses):		

EE 122B	Introduction to Biomedical Electronics	3
EE 124	Introduction to Neuroelectrical Engineering	3
EE 169	Introduction to Bioimaging	3
EE 202	Electrical Engineering in Biology and Medicine	3
EE 225	Bio-chips, Imaging and Nanomedicine	3

CIRCUITS AND DEVICES

This specialty area provides practical, hands-on experience with electronic circuits as well as fundamental understanding of electronic devices and design techniques for building electronics.

For this sequence taking the EE 101 core first is preferable.

Required Course:		
EE 101B	Circuits II	4
Design Course:		
EE 133 (WIM/Design)	Analog Communications Design Laboratory	4
EE 152 (WIM/Design)	Green Electronics	4
EE 153 (WIM/Design)	Power Electronics	4
Electives (choose two electives from below for a total of 4 courses):		
EE 114	Fundamentals of Analog Integrated Circuit Design	3
EE 116	Semiconductor Device Physics	3
EE 122A	Analog Circuits Laboratory	3
EE 212	Integrated Circuit Fabrication Processes	3
EE 214B	Advanced Analog Integrated Circuit Design	3
EE 216	Principles and Models of Semiconductor Devices	3
EE 271	Introduction to VLSI Systems	3

COMPUTER HARDWARE

This specialty area provides in-depth understanding in exploring the wide range of digital systems; architectures associated application areas that can immensely benefit from both commercial computing platforms and application-specific digital systems. Students obtain unique hands-on experience in the key elements that are essential for successful hardware/software system design: Digital system design principles, computer organization and architecture, and ways in which software systems interface with hardware designs. For this sequence taking the EE 108 core first is preferable; additionally, taking the CS 106 sequence earlier is also advisable.

Required Courses:		
CS 107	Computer Organization and Systems (prerequisite for EE 180)	3-5
EE 180	Digital Systems Architecture	4
Design Course		
EE 109 (WIM/Design) or EE 152 (Design)	Digital Systems Design Lab Green Electronics	4 4
Electives (choose two electives from below for a total of 4 courses):		
EE 271	Introduction to VLSI Systems	3
EE 273	Digital Systems Engineering	3
EE 282	Computer Systems Architecture	3

COMPUTER SOFTWARE

This specialty area provides students with a broad range of software classes and projects available in Computer Science. For this sequence taking both the CS 106 and EE 180 core classes first is preferable.

Required Course		
CS 107	Computer Organization and Systems (prerequisite for EE 180)	3-5
EE 180	Digital Systems Architecture	4
Design Course		
CS 194W (WIM/Design) or EE 152 (WIM/Design)	Software Project (WIM) or Green Electronics	3 4
Electives (choose two electives from below for a total of 4 courses):		
CS 108	Object-Oriented Systems Design	3-4
CS 110	Principles of Computer Systems	3-5
CS 140	Operating Systems and Systems Programming	3-4
CS 143	Compilers	3-4
CS 144 or EE 284	Introduction to Computer Networking or Introduction to Computer Networks	3-4
CS 145	Introduction to Databases	3-4
CS 148	Introduction to Computer Graphics and Imaging	3-4

ENERGY AND ENVIRONMENT

The Green-EE area focuses on the confluence of new technologies for clean energy, systems engineering at several levels and innovations in making smarter electronics that leverage software and information theory technologies. All areas from the Core (101, 102 and 108) provide interesting and different entry points to this focus area.

Required Course:		
EE 101B or EE 180	Circuits II or Digital Systems Architecture	4 4
Design Course:		
EE 134 (WIM) or EE 152 (WIM) or EE 153 (WIM) or EE 168 (WIM)	Introduction to Photonics Green Electronics Power Electronics Introduction to Digital Image Processing	4
Electives (choose two electives from below for a total of 4 courses):		
EE 116	Semiconductor Device Physics	3
EE 151	Sustainable Energy Systems	3
EE 263	Introduction to Linear Dynamical Systems	3
EE 293A	Fundamentals of Energy Processes	3-4
EE 293B	Fundamentals of Energy Processes	3
CEE 155	Introduction to Sensing Networks for CEE	4
CEE 173A	Energy Resources	4-5
CEE 176A	Energy Efficient Buildings	3-4
CEE 176B	Electric Power: Renewables and Efficiency	3-4
ENGR 105	Feedback Control Design	3
ENGR 205	Introduction to Control Design Techniques	3
MATSCI 156	Solar Cells, Fuel Cells, and Batteries: Materials for the Energy Solution	3-4
ME 185	Electric Vehicle Design	3

MUSIC

This specialty area bridges the circuits, signals and systems areas based on the specific application of music and many of the courses are EE related courses from the Computer Music (CCRMA) Center. For this sequence taking EE 101 and 102 or Music 320A first is preferable.

Required Course:		
EE 102B or MUSIC 320A	Signal Processing and Linear Systems II or Introduction to Audio Signal Processing Part I: Spectrum Analysis	4 4
Design Course:		
EE 109 (WIM/Design) or EE 265 (Design)	Digital Systems Design Lab or Digital Signal Processing Laboratory	4 4
Electives (choose two electives from below for a total of 4 courses):		
EE 122A	Analog Circuits Laboratory	3
EE 264 or EE 265 (Design)	Digital Signal Processing or Digital Signal Processing Laboratory	3-4
MUSIC 256A	Music, Computing, and Design I: Software Paradigms for Computer Music	1-4
MUSIC 256B	Music, Computing, Design II: Mobile Music	1-4
MUSIC 320B	Introduction to Audio Signal Processing Part II: Digital Filters	3-4
MUSIC 420A	Signal Processing Models in Musical Acoustics	3-4
MUSIC 421A	Audio Applications of the Fast Fourier Transform (FFT)	3-4
MUSIC 422	Perceptual Audio Coding	3
MUSIC 424	Signal Processing Techniques for Digital Audio Effects	3-4

PHOTONICS, SOLID STATE AND ELECTROMAGNETICS

This specialty area addresses a broad range of new device structures, including concepts leveraged by electromagnetics. The device courses draw heavily from the quantum mechanics field and often use advanced materials to achieve desired electrical and optical properties. There are applications in high-speed communications and computation systems as well as medical imaging. For this sequence taking the EE 101 core first is preferable; for the EE 134 course, more physics background and interest is typically required. Taking EE 65 and EE 142 is strongly advised; additionally, EE 142 can be included in the specialty sequence, but only if not used to fulfill the Physics in EE core requirement.

Required Course:		
EE 101B	Circuits II	4
Design Course:		
EE 134 (WIM/Design)	Introduction to Photonics	4
Electives (choose two electives from below for a total of 4 courses):		
EE 116	Semiconductor Device Physics	3
EE 136	Introduction to Nanophotonics and Nanostructures	3
EE 142	Engineering Electromagnetics	3
EE 216	Principles and Models of Semiconductor Devices	3
<i>continued on next page</i>		

EE 222	Applied Quantum Mechanics I	3
EE 223	Applied Quantum Mechanics II	3
EE 228	Basic Physics for Solid State Electronics	3
EE 236A	Modern Optics	3
EE 236B	Guided Waves	3
EE 242	Electromagnetic Waves	3
EE 247	Introduction to Optical Fiber Communications	3

SIGNAL PROCESSING, COMMUNICATIONS AND CONTROLS

This specialty area provides the math and theoretical understanding of signals and signal processing, as well as feedback control. The concepts have a broad range of applications including: imaging, wireless; digital signal processing (DSP) and embedded systems. More math courses such as Math 104 on applied matrix theory may be helpful.

Required Course:		
EE 102B	Signal Processing and Linear Systems II	4
Design Course (choose one):		
EE 133 (WIM/Design)	Analog Communications Design Laboratory	4
EE 168 (WIM/Design)	Introduction to Digital Image Processing	4
EE 262 (Design)	Two-Dimensional Imaging	3
EE 265 (Design)	Digital Signal Processing Laboratory	4
Electives (choose two electives from below for a total of 4 courses):		
EE 107	Networked Systems	3
EE 124	Semiconductor Device Physics	3
EE 169	Introduction to Bioimaging	3
EE 179	Analog and Digital Communication Systems (Not given 2014-15; recommend EE 107 as alternative)	3
EE 261	The Fourier Transform and Its Applications	3
EE 263	Introduction to Linear Dynamical Systems	3
EE 264 or EE 265 (Design)	Digital Signal Processing or Digital Signal Processing Laboratory	3-4
EE 278B	Introduction to Statistical Signal Processing	3
EE 279	Introduction to Digital Communication	3
ENGR 105	Feedback Control Design	3
ENGR 205	Introduction to Control Design Techniques	3

DESIGN COURSE (ONE COURSE, 3-4 UNITS*):

EE 109	Digital Systems Design Lab
EE 133	Analog Communications Design Laboratory
EE 134	Introduction to Photonics
EE 152	Green Electronics
EE 153	Power Electronics
EE 168	Introduction to Digital Image Processing
EE 262	Two-Dimensional Imaging
EE 265	Digital Signal Processing Laboratory
CS 194W	Software Project

*The recommended Design courses for each specialty are given within the specialty course lists; however, this is not a strict requirement.

DEPTH ELECTIVES (12 UNITS):

May include up to two additional Engineering Fundamentals, any CS 193 course and any letter-graded EE or EE Related courses (minus any previously noted restrictions). Introductory Seminars, EE 191 and CS 106A do not count toward the 60 units. For a complete list of EE Related courses, go to the MS degree page in the EE Graduate Handbook at http://ee.stanford.edu/academics/graduate_degree_progress.

RESEARCH EXPERIENCE FOR UNDERGRADUATES

The Electrical Engineering Department at Stanford University invites undergraduates majoring in EE to participate in its REU Summer Program from June to August. The program is designed to give undergraduates an opportunity to work with members of the EE Faculty and their research groups on advanced research topics. There is more detail on the EE page on the UGHB website. For complete information and instructions on applying, please visit <http://ee.stanford.edu/academics/reu>.

Study Abroad Program

Stanford's Overseas Studies Program is a great opportunity for students to build their language and cultural skills abroad. Some of the most popular programs with Electrical Engineering students are in China, Japan and Germany. In many cases there are summer job opportunities as well. Each program has different and specific language requirement that may require early and careful planning. For example, the core classes may be offered during quarters that conflict with the study abroad. For more information, see the "Overseas Studies" section in Chapter 8 of this handbook.

OBJECTIVES AND OUTCOMES FOR ELECTRICAL ENGINEERING

Objectives:

1. *Technical Knowledge:* Provide a basic knowledge of electrical engineering principles along with the required supporting knowledge of mathematics, science, computing, and engineering fundamentals. The program must include depth in at least one specialty area, currently including Bio-electronics and Bio-imaging; Circuits and Devices; Computer Hardware; Computer Software; Energy and Environment; Music; Photonics, Solid State, and Electromagnetics; and Signal Processing, Communications and Control.
2. *Laboratory and Design Skills:* Develop the basic skills needed to perform and design experimental projects. Develop the ability to formulate problems and projects and to plan a process for solutions taking advantage of diverse technical knowledge and skills.
3. *Communications Skills:* Develop the ability to organize and present information, and to write and speak effective English.
4. *Preparation for Further Study:* Provide sufficient breadth and depth for successful subsequent graduate study, post-graduate study, or lifelong learning programs.
5. *Preparation for the Profession:* Provide an appreciation for the broad spectrum of issues arising in professional practice, including teamwork, leadership, safety, ethics, service, economics, and professional organizations.

Outcomes:

- (a) An ability to apply knowledge of mathematics, science, and engineering
- (b) An ability to design and conduct experiments, as well as to analyze and interpret data
- (c) An ability to design a system, component, or process to meet desired needs within realistic constraints such as economic, environmental, social, political, ethical, health and safety, manufacturability, and sustainability
- (d) An ability to function on multi-disciplinary teams
- (e) An ability to identify, formulate, and solve engineering problems
- (f) An understanding of professional and ethical responsibility
- (g) An ability to communicate effectively
- (h) The broad education necessary to understand the impact of engineering solutions in a global, economic, environmental, and societal context
- (i) A recognition of the need for, and an ability to engage in, life-long learning
- (j) A knowledge of contemporary issues
- (k) An ability to use the techniques, skills, and modern engineering tools necessary for engineering practice
- (l) Background for admission to engineering or other professional graduate programs

Electrical Engineering

Typical Sequence of Courses

<i>Freshman</i>	<i>Sophomore</i>	<i>Junior</i>
MATH 41 (A)	EE MATH Elect (or JR yr)	EE 101A (W)
MATH 42 (A,W)	CME 102 (A,W,S)	EE 101B (S)
CME 100 (A)	ENGR 40 (W) or 40M (A,S) or 40P	EE 102A (W)
PHYS 41 (W)	EE 100 (A)	EE 102B (S)
PHYS 43 (S) (+ opt. E40)	Science/Math	CS 106B (A,W,S) or 106X (A,W)
PHYS 45 (A) (Optional)	ENGR Fund (or JR yr)	EE 108 (A,W)
		EE 180 (W)
		EE178(A,S) or CS109 (A,W,S)
		EE 65 (S) or EE 41 (not offered 14-15) or 142
		Design Course (or SR year)
		Tech in Society (or SR year)

Junior/Senior Year: Choose one Specialty Area below (12-20 units)

Typical courses: See Specialty Area descriptions for course options

<p>Bioelectronics & Bio-imaging</p> <p>EE 122B EE 124 EE 134 EE 168 EE 169 EE 202 EE 225</p>	<p>Circuits and Devices</p> <p>EE 114 EE 116 EE 122A EE 133 EE 152 EE 153 EE 212 EE 214B EE 216 EE 271</p>	<p>Computer Hardware</p> <p>CS 107 EE 109 EE 152 EE 271 EE 273 EE 282</p>	<p>Computer Software</p> <p>CS 107 CS 108 CS 110 CS 140 CS 143 CS 145 CS 148 CS 194W CS 144 or EE 284 EE 152</p>
<p>Energy and Environment</p> <p>EE 116 EE 134 EE 151 EE 152 EE 153 EE 168 EE 263 EE 293A/B CEE 155 CEE 173A CEE 176A CEE 176B ENGR 105/205 MATSCI 156 ME 185</p>	<p>Music</p> <p>EE 109 EE 122A EE 264 or 265 MUSIC 256A MUSIC 256B MUSIC 320B MUSIC 420A MUSIC 421A MUSIC 422 MUSIC 424</p>	<p>Photonics, Solid State and Electromagnetics</p> <p>EE 116 EE 134 EE 136 EE 142 EE 216 EE 222 EE 223 EE 228 EE 236A EE 236B EE 242 EE 247</p>	<p>Signal Processing, Communications and Controls</p> <p>EE 107 EE 124 EE 133 EE 168 EE 169 EE 179 EE 261 EE 262 EE 263 EE 264 or 265 EE 278B EE 279 ENGR 105/205</p>

Electrical Engineering

Standard Plan

	<i>Fall</i>			<i>Winter</i>				<i>Spring</i>				
	Math/			Math/				Math/				
<i>Freshman</i>	Class	Sci.	Engr.	Other	Class	Sci.	Engr.	Other	Class	Sci.	Engr.	Other
	MATH 41	5	-	-	MATH 42	5	-	-	CME 100	5	-	-
	Science ¹	4	-	-	PHYSICS 41	4	-	-	PHYSICS 43	4	-	-
	INTROSEM	-	-	3	THINK	-	-	4	GER	-	-	5
					PWR 1	-	-	4				
	<i>Subtotals</i>	<i>9</i>	<i>0</i>	<i>3</i>	<i>Subtotals</i>	<i>9</i>	<i>0</i>	<i>8</i>	<i>Subtotals</i>	<i>9</i>	<i>0</i>	<i>5</i>
	Total			12	Total			17	Total			14
<i>Sophomore</i>	EE 100	-	-	1	EE 101A	-	4	-	Depth Req'd	-	4	-
	ENGR 40M ²	-	-	5	EE 102A	-	4	-	CS 106A	-	5	-
	CME 102	5	-	-	EE MATH ³	4	-	-	EE 65	-	3	-
	INTROSEM	-	-	3	PWR 2	-	-	4				
	<i>Subtotals</i>	<i>5</i>	<i>0</i>	<i>9</i>	<i>Subtotals</i>	<i>4</i>	<i>8</i>	<i>4</i>	<i>Subtotals</i>	<i>0</i>	<i>12</i>	<i>0</i>
	Total			14	Total			16	Total			12
<i>Junior</i>	GER	-	-	5	GER	-	-	5	GER	-	-	5
	Elective	-	-	4	EE 108	-	4	-	GER	-	-	5
	CS 106B	-	5	-	Depth Elective	-	3	-	EE 178	4	-	-
	EE 103	-	5	-	EE Elective	-	3	-	EE Elective	-	3	-
	<i>Subtotals</i>	<i>0</i>	<i>10</i>	<i>9</i>	<i>Subtotals</i>	<i>0</i>	<i>10</i>	<i>5</i>	<i>Subtotals</i>	<i>4</i>	<i>3</i>	<i>10</i>
	Total			19	Total			15	Total			17
<i>Senior</i>	LANGUAGE	-	-	5	LANGUAGE	-	-	5	LANGUAGE	-	-	5
	Depth Elective	-	3	-	Depth Design	-	4	-	GER	-	-	5
	EE Elective	-	3	-	EE Elective	-	3	-	Elective	-	-	4
	ENGR FUND	-	4	-	TIS	-	-	4				
	<i>Subtotals</i>	<i>0</i>	<i>10</i>	<i>5</i>	<i>Subtotals</i>	<i>0</i>	<i>7</i>	<i>9</i>	<i>Subtotals</i>	<i>0</i>	<i>0</i>	<i>14</i>
	Total			15	Total			16	Total			14

Total Math & Science Units: 40
 Total Engineering Units: 60
 Total Other Units: 81
Total Units: 181

Notes:

- [1] PHYSICS 45, CHEM 31, MATH 104, or MATH 131P recommended, depending on specialty sequence
 - [2] Note that ENGR 40M is currently subject to limited enrollment. Alternatively, ENGR 40 (a less hands on version of ENGR 40M) is offered Winter quarter and is not subject to limited enrollment.
 - [3] EE 102B, EE 103, CME 104, EE 142, Math 113, or CS 103; EE 102B may be used only if not listed in EE Depth; EE 142 may be used only if not listed in Core
- ➔ The School of ENGR encourages a quarter abroad. For detail on in-person or online ENGR course options see the Overseas Programs & Engineers page on the UGHB website or Chap 8 of the UGHB.

Electrical Engineering

Standard + AP Credit¹ and Coterm²

	<i>Fall</i>				<i>Winter</i>				<i>Spring</i>			
	Math/ Sci.	Engr.	Other	Class	Math/ Sci.	Engr.	Other	Class	Math/ Sci.	Engr.	Other	
<i>Freshman</i>	CS 106A	-	5	-	CS 106B	-	5	-	CME 100	5	-	-
	CME 102	5	-	-	PHYSICS 41	4	-	-	PHYSICS 43	4	-	-
	THINK	-	-	4	GER	-	-	5	ENGR 40 ³	-	-	5
					PWR 1	-	-	4	INTROSEM	-	-	3
	<i>Subtotals</i>	5	5	4	<i>Subtotals</i>	4	5	9	<i>Subtotals</i>	9	0	8
	Total	14		Total	18		Total	17				
<i>Sophomore</i>	EE 100	-	-	1	EE 101A	-	4	-	Depth Req'd	-	4	-
	GER	-	-	5	EE 102A	-	4	-	EE 65	-	3	-
	EE 103	-	5	-	GER	-	-	5	EE MATH ⁴	4	-	-
	INTROSEM	-	-	3	PWR 2	-	-	4	GER	-	-	5
	<i>Subtotals</i>	0	5	9	<i>Subtotals</i>	0	8	9	<i>Subtotals</i>	4	7	5
	Total	14		Total	17		Total	16				
<i>Junior</i>	EE 108	-	4	-	GER	-	-	5	EE Elective	-	3	-
	ENGR FUND.	-	4	-	Depth Design	-	4	-	EE 178	4	-	-
	Depth Elective	-	3	-	Depth Elective	-	3	-	TIS	-	-	4
	GER	-	-	5	Elective	-	-	4	Elective	-	-	4
	<i>Subtotals</i>	0	11	5	<i>Subtotals</i>	0	7	9	<i>Subtotals</i>	4	3	8
	Total	16		Total	16		Total	15				
<i>Senior</i>	LANGUAGE	-	-	5	LANGUAGE	-	-	5	LANGUAGE	-	-	5
	EE Elective	-	3	-	EE Elective	-	3	-	EE Coterm	-	1	-
	EE Elective	-	3	-	EE Coterm	-	3	-	EE Coterm	-	3	-
	EE Coterm	-	3	-	EE Coterm	-	3	-	EE Coterm	-	3	-
	<i>Subtotals</i>	0	9	5	<i>Subtotals</i>	0	9	5	<i>Subtotals</i>	0	7	5
	Total⁵	14		Total⁵	14		Total⁵	12				

Total Math & Science Units: 40
 Total Engineering Units: 60
 Total Other Units: 81
Total Units: 181

Notes:

- [1] +AP assumes AP CALC BC (10 units) and AP CHEM (4 units)
- [2] Coterm planning designed to allow students to complete the M.S. degree in their fifth year
- [3] Alternatively, ENGR 40M (a more hands on version of ENGR 40) is offered Fall quarter. However, it is currently subject to limited enrollment.
- [4] EE 102B, EE 103, CME 104, EE 142, Math 113, or CS 103; EE 102B may be used only if not listed in EE Depth; EE 142 may be used only if not listed in Core
- [5] Totals include only undergrad units (including AP credit)

→ The School of ENGR encourages a quarter abroad. For detail on in-person or online ENGR course options see the Overseas Programs & Engineers page on the UGHB website or Chap 8 of the UGHB.

Electrical Engineering

Standard +AP Credit¹ and Study Abroad²

	<i>Fall</i>				<i>Winter</i>				<i>Spring</i>			
	Math/				Math/				Math/			
<i>Freshman</i>	Class	Sci.	Engr.	Other	Class	Sci.	Engr.	Other	Class	Sci.	Engr.	Other
	CME 102	5	-	-	CS 106B	-	5	-	CME 100	5	-	-
	CS 106A	-	5	-	PHYSICS 41	4	-	-	PHYSICS 43	4	-	-
	THINK	-	-	4	INTROSEM	-	-	3	ENGR 40 ³	-	-	5
					PWR 1	-	-	4				
	<i>Subtotals</i>	5	5	4	<i>Subtotals</i>	4	5	7	<i>Subtotals</i>	9	0	5
	Total	14			Total	16			Total	14		
<i>Sophomore</i>	EE 100	-	-	1	EE 101A	-	4	-	Depth Req'd	-	4	-
	EE MATH ⁴	4	-	-	EE 102A	-	4	-	EE 178	4	-	-
	EE 103	-	5	-	PWR 2	-	-	4	EE 65	-	3	-
	INTROSEM	-	-	3					GER	-	-	5
	<i>Subtotals</i>	4	5	4	<i>Subtotals</i>	0	8	4	<i>Subtotals</i>	4	7	5
	Total	13			Total	12			Total	16		
<i>Junior</i>	LANGUAGE	-	-	5	LANGUAGE	-	-	5	LANGUAGE	-	-	5
	EE 108	-	4	-	ENGR FUND.	-	4	-	GER	-	-	5
	Depth Elective	-	3	-	Depth Elective	-	3	-	GER	-	-	5
									<i>Study Abroad</i>			
	<i>Subtotals</i>	0	7	5	<i>Subtotals</i>	0	7	5	<i>Subtotals</i>	0	0	15
	Total	12			Total	12			Total	15		
<i>Senior</i>	GER	-	-	5	GER	-	-	5	GER	-	-	5
	TIS	-	-	4	Depth Design	-	4	-	EE Elective	-	3	-
	EE Elective	-	3	-	EE Elective	-	3	-	Elective	-	-	4
	EE Elective	-	3	-	Elective	-	-	4				
	<i>Subtotals</i>	0	6	9	<i>Subtotals</i>	0	7	9	<i>Subtotals</i>	0	3	9
	Total	15			Total	16			Total	12		

Total Math & Science Units: 40
 Total Engineering Units: 60
 Total Other Units: 81
Total Units: 181

Notes:

- [1] Assumes AP CALC BC (10 units) and AP CHEM (4 units)
 - [2] Assumes most popular programs (Berlin/Kyoto, Junior Year, Spring Qtr)
 - [3] Alternatively, ENGR 40M (a more hands on version of ENGR 40) is offered Fall quarter. However, it is currently subject to limited enrollment.
 - [4] EE 102B, EE 103, CME 104, EE 142, Math 113, or CS 103; EE 102B may be used only if not listed in EE Depth; EE 142 may be used only if not listed in Core
- ➔ The School of ENGR encourages a quarter abroad. For detail on in-person or online ENGR course options see the Overseas Programs & Engineers page on the UGHB website or Chap 8 of the UGHB.

INSTRUCTIONS FOR DECLARING MAJOR IN ELECTRICAL ENGINEERING

Declaring an EE major consists of the following steps:

1. Go into Axess and choose the EE major to declare. Do not choose the Honors option on Axess unless you have already submitted an Honors application and Honors thesis proposal to the department.
2. Fill out a copy of the Undergraduate Sign-Up Sheet, which can be found online at <https://ee.stanford.edu/current-students/undergraduate-students>. The "Area(s) of Interest" is particularly important to assist in the choice of a faculty advisor. It can always be changed.
3. Meet with the Associate Chair of Undergraduate Education: Please send an email to rdutton@stanford.edu to make an appointment. Make sure to bring your Undergraduate Sign-up Sheet, unofficial transcript, and academic file (if available from your previous advisor) to the meeting. The purpose of the meeting is to go over the basics of getting a BS in EE, and to assign an EE faculty member to be your major advisor.
4. After the meeting, bring your Undergraduate Sign-up Sheet to the EE Degree Progress Officer in Packard 177, who will approve your major declaration and enter your advisor's name in Axess. We will also add your email to the EE undergraduate email list (also part of the department-wide student email list. These lists are used for announcements about academic requirements, seminars, research opportunities and other events.

Note: The online version of your major (link from the Home or Major Programs page of the UGHB website) is considered the definitive version of 2014-15 requirements; corrections or updates may have been made after the printed and pdf versions were published in August 2014.

- ★ You must use a program sheet from a year you have been enrolled at Stanford.

Stanford University ♦ School of Engineering
Electrical Engineering
2014–2015 Program Sheet

A PRELIMINARY completed and signed PROGRAM SHEET (PS) must be submitted to the department before the end of the quarter following the quarter in which the EE major is declared. (This version is a PLANNING DOCUMENT, intended to outline the courses that will fulfill the degree requirements; this plan can be changed at any time, with the advice of the major advisor, until the final document is submitted)
The FINAL VERSION of the PS is due to the department no later than one month prior to the last quarter of senior year. This document must satisfy all university requirements as outlined in the UGHB.

Follow all requirements as stated for the year of the program sheet used.

Name: _____
 Phone: _____
 Today's Date: _____

SU ID#: _____
 Email: _____
 Month/Yr B.S. expected: _____

Mathematics and Science Requirements (40 units minimum)

Dept	Course	Title	SoE Transfer/AP Approval			Unit Total	Grade
			✓ if Transfer	SoE Initials	Date		
Mathematics							
MATH	41	Calculus (req'd)				5	
MATH	42	Calculus (req'd)				5	
CME	100	Vector Calculus for Engineers (req'd, see note 1)				5	
CME	102	Ordinary Differential Equations for Engineers (req'd; see note 1)				5	
		One Additional 100-level EE Math Class (see note 2)				3 to 5	
		One Statistics/Probability course (EE 178 or CS 109 req'd)				4 to 5	
<i>Mathematics Unit Total</i>							

Science (12 units minimum)

PHYS	41	Mechanics (req'd)				4	
PHYS	43	Electricity and Magnetism (req'd)				4	
		Science elective(s); see UGHB Fig. 3-2 for approved list					
<i>Science Unit Total (12 units minimum)</i>							
<i>Mathematics and Science Unit Total (40 units minimum)</i>							

Technology in Society Requirement (1 course required; see UGHB Fig. 3-3 for SoE approved list)

--	--	--	--	--	--	--	--

NOTES

- * **All courses taken for the major must be taken for a letter grade if that option is offered by the instructor.**
 - * Form is available as an Excel file at ughb.stanford.edu. Must use program sheet from a year you are enrolled at Stanford.
 - * Delete courses and units not taken so totals are correct.
 - * Minimum Combined Grade Point Average for all courses in Engineering Topics (Fundamental and Depth courses) is 2.0.
 - * Transfer and AP credits in Math, Science, Funds., & TIS must be approved by the SoE Dean's Office. Transfer credits in Engineering Depth must be approved by the advisor. Transfer credit information & petitions at <http://ughb.stanford.edu/>.
 - * All courses on this form must be listed under only one category; No double counting.
- (1) Math 52 and Math 53 can be substituted for CME 100 and CME 102. CME100 is not required as pre-req for CME 102.
- (2) Must take one additional math course from the following: EE 102B, EE 103, CME 104, EE 142, Math 113, CS 103; EE 102B may be used only if not listed in EE Depth; EE 142 may be used only if not listed in Core.

Engineering Topics (Fundamental + Depth courses combined must equal 60 units. See note 3)

Dept	Course	Title	SoE Transfer/AP Approval			Unit Total	Grade
			✓ if Transfer	SoE Initials	Date		
Engineering Fundamentals (3 courses required)							
ENGR	70B or X	Prog Abst (CS106B or 106X) (req'd)				5	
ENGR	40	EE-related fundamental (alternatives: 40M or 40P)				5	
ENGR		Fundamentals Elective (outside of EE and CS; see UGHB Fig. 3-4 for approved list)					
<i>Engineering Fundamentals Unit Total</i>							

Core EE Courses (all required)

EE	100	The Electrical Engineering Profession (see note 6)				1	
EE	101A	Circuits I				4	
EE	102A	Signal Processing and Linear Systems I				4	
EE	108	Digital System Design				4	
EE	65	Modern Physics for Engineers (see note 4)				5	
<i>Core Courses Unit Total</i>						18	

Engineering Depth Area :

		Required Course				4	
		Design Course in Depth Area (see note 5 for options & WIM)				3 to 4	
		Depth Area Elective					
		Depth Area Elective					
<i>Depth Unit Totals</i>							

Mathematics and Science (40 units minimum)

Engineering Topics (Fundamentals + Engr Depth) (60 units minimum)

Program Approvals

Advisor

Printed Name: _____
Signature: _____

Date: _____

Departmental

Printed Name: _____
Signature: _____

Date: _____

School of Engineering (signature not required prior to graduation)

Printed Name: _____
Signature: _____

Date: _____

NOTES (continued from page 1)

- (3) Freshman and Sophomore seminars, EE 191, and CS 106A do not count toward the 60 units.
- (4) Other options include EE 41 (not offered 14-15) or EE 142. Cannot take ENGR 40P/EE 41 to fulfill the Engineering Fundamentals requirement if it is used to meet the Physics in EE Core Course requirement. EE 142 cannot be used for both Physics in EE and as a Depth Elective.
- (5) Courses that fulfill both the Design and WIM requirements for 2014-15 are: EE109, EE133, EE134, EE152, EE153, EE168 or CS194W. Design only courses are: EE 262 or EE 265. EE 191W may satisfy WIM only if it is a follow-up to an REU, independent study project or as part of an Honors thesis project, where a faculty agrees to provide supervision of writing a technical paper and with suitable support from the Writing Center.
- (6) Juniors and seniors may petition for a 200-level seminar class depth area

ENGINEERING PHYSICS

The Engineering Physics program is designed for students who have an interest in and an aptitude for both engineering and physics. The program provides students with a firm foundation in physics and mathematics, together with engineering and problem-solving skills. This background prepares students to tackle complex problems in multidisciplinary areas that are at the forefront of 21st-century technology, such as biophysics, computational science, solid state devices, quantum optics and photonics, materials science, nanotechnology, electromechanical systems, energy systems, renewable energy, and any engineering field that requires a very solid background in physics. Because the program emphasizes science, mathematics and engineering, students are well prepared to pursue graduate work in engineering, physics, or applied physics.

Engineering Physics majors may participate in on-campus summer research programs in engineering, physics, or applied physics. To conduct research with a faculty member in the School of Engineering, students apply to the summer research program for the department of the faculty mentor. To conduct research with a faculty member in the Physics or Applied Physics Departments or at SLAC, students apply through the Physics, Applied Physics and SLAC program at <https://physics.stanford.edu/undergraduate-program/summer-research>

REQUIREMENTS

Math and Science Requirements:

Math: MATH 51 and 52 or CME 100 and 104, MATH 53 or CME 102, MATH 131P (MATH 173 can be taken in place of MATH131P).

Science: PHYSICS (41, 42, 43, 44*, 45, 46, 70) or (61, 62, 63, 64, 65, 67)

PHYSICS 42 or 62. Mechanics Lab: Required for students who take 41 or 61 in 2011-12 or later.

*PHYSICS 67 strongly recommended in place of 44 for students taking the PHYSICS 40 series.

Technology in Society: One 3-5 unit approved course required; see Figure 3-3 for SoE approved course list.

Engineering Fundamentals and Depth:

At least 45 of the units in Engineering Fundamentals, Required Depth Classes, Required Depth Electives, and other electives must be School of Engineering units.

Engineering Fundamentals:

Three courses from approved list; see Figure 3-4. Fundamentals courses acceptable for the core program (below) may also be used to satisfy the three-course Fundamentals requirement as long as 45 unduplicated units of engineering are taken

A course in computer science, such as CS106A, B, or X, is recommended.

Engineering Physics Depth - Core Courses Required in All Specialty Areas:

Advanced Mathematics	One elective such as EE 261, PHYSICS 112, CS 109 or CME 106. Also EE 263, any Math or Statistics course numbered 100 or above; any CME course numbered 200 or above, except CME 206.
Advanced Mechanics and Dynamics	AA 242A or ME 333 or PHYSICS 110 (ENGR 15 is allowed 2011-12 and earlier)
Intermediate Electricity and Magnetism	EE 141 and 242 or PHYSICS 120 and 121
Numerical Methods	AP 215 or CME 108 or CME 206/ME 300C or PHYSICS 113
Electronics Laboratory	ENGR 40 or EE 101B or EE 122A or PHYSICS 105 or APPPHYS 207 (ENGR 40A does not satisfy this requirement)
Quantum Mechanics	EE 222 and 223 or PHYSICS 130 and 131
Thermodynamics, Kinetics, & Statistical Mechanics	PHYSICS 170 and 171, or ME 346A (not offered every year)

Writing in the Major (WIM)

- BIOE 131 (for Biophysics specialty only)
- CS 181W (for Computational Science specialty only)
- EE 134 (appropriate for Photonics specialty)
- EE 152 (appropriate for Renewable Energy specialty)
- ENGR 199W (only if student is pursuing an independent research project)
- MATSCI 161 or 164 (appropriate for Materials Science, Renewable Energy and Solid State Physics specialties)
- ME 112 (for Electromechanical System Design specialty only)
- ME 131A and 140 (for Energy Systems specialty only)

PHYSICS 107 (appropriate for Photonics specialty)

Design Course:

At least one of the following design-project courses must be included in each program:
CS 108, EE 133, EE 134, EE 152, ME 203, ME 210, PHYSICS 108.

Three Courses from one of the following Specialty Areas:

1. The **Biophysics** specialty prepares students to employ methods in physics to the study of biological systems. Students have the opportunity to learn about the physical biology of systems on a broad range of scales, techniques developed in biophysics for imaging, measuring, and manipulating biological systems, and the application of quantitative analysis techniques to topics in biology and genomics. Choose three courses from BioE 41, 42, 44, 101, 103, 123, Bio 132, EE 169, AP 192, and CS 262. Students taking this specialty may use BioE 41 and 42 to satisfy the Thermodynamics, Kinetics and Statistical Mechanics requirement (substitution recommended), but then cannot count BioE 41 and 42 toward the three courses required for the specialty. Students taking this specialty may use BioE 123 to satisfy *either* the Electronics Lab *or* Design Course requirement (substitution recommended), but then cannot count BioE 123 toward the three courses required for the specialty. EE 369A, B or C may be taken instead of EE 169. BioE 131 may be used to satisfy the WIM requirement for this specialty. BioE 80 recommended as an Engineering Fundamental. EE 261 recommended for the Advanced Math requirement.
2. The **Computational Science** specialty prepares students to apply modern computational techniques to problems in engineering and applied science, and to the analysis of data. Students have the opportunity to study computational theory and algorithms, as well as applications in modeling and data analysis. Choose three courses from CS 103, 121 or 221, 154, 161, 164, 205A, 205B, 228, 229 or 229A; CME 212, 215A, 215B, or any CME course with course number greater than 300 and less than 390; Stats 202, 213. CS 181W may be used to satisfy the WIM requirement for this specialty. CS 106A/B or X recommended as an Engineering Fundamental. CS 108 recommended for the Design Course requirement. CS 109 and 109L recommended for the Advanced Math requirement.
3. The **Electromechanical System Design** specialty provides the opportunity for students to explore the process of design, analysis, and realization of modern electromechanical systems including “smart products” with embedded sensing and actuation. Take ME 80,

ME 112, and ME 210 or EE 118. ME 112 satisfies the WIM requirement. Take ME 203 as the Design course; ME 101 and ME 103D also recommended.

4. The **Energy Systems** specialty provides the opportunity for students to explore how energy is manipulated in both device applications and for modern energy conversion systems including electrical power, transportation, and propulsion. Take ME 131A, ME 131B, and ME 140. The combination of ME 131A and 140 satisfies WIM requirement. ME 70 also recommended.
5. In the **Materials Science** specialty, students learn how to design and synthesize materials with particular structures at the nanometer and micrometer scale that provide special electrical, optical, magnetic or mechanical properties. Students can learn how to use these materials to make integrated circuits, light-emitting diodes, solar cells, fuel cells, microelectromechanical systems and other advanced devices. Choose three from any MATSCI courses numbered 151 to 199 (except 159Q) or APPPHYS 272/PHYSICS 172. MATSCI 161 or 164 satisfies the WIM requirement. In addition, ENGR 31 or CHEM 31 highly recommended.
6. The **Photonics** specialty provides the opportunity for students to learn about the emission, transmission, amplification, detection, modulation and switching of optical and infrared light. Students can apply this knowledge to optoelectronic devices such as lasers, photodetectors, waveguides and photonic crystals, or to quantum information science, with applications in quantum communication and quantum computing. Choose from EE 216, EE 231, EE 232, EE 234, EE 243, EE 268, MATSCI 199. PHYSICS 107 or EE 134 recommended as the WIM course. EE 134 recommended as Design course.
7. In the **Renewable Energy** specialty, students explore energy conversion and storage technologies that are relevant in renewable energy systems, such as solar cells, wind turbines, batteries, fuel cells, and hydrogen production and storage. Choose from CEE 176B, EE 152, EE 153, EE 237, EE 293A, EE 293B, MATSCI 156, MATSCI 302, MATSCI 316, ME 260. EE 152 recommended as WIM and Design course.
8. In the **Solid State Physics** specialty, students have the opportunity to learn about the macroscopic physical properties of solids, including electrical, magnetic and optical properties, superconductivity, and heat transfer in solids. Students learn how these properties can be manipulated and applied in electronic devices. Choose from APPPHYS 272/PHYSICS 172, APPHYS 273, EE 116, EE 216, MATSCI 199.
9. **Other Specialty:** With approval of advisor and by petition, a set of three courses in one area of concentration (e.g., astrophysics and astronautics; quantum information).

Engineering Physics

Typical Sequence of Courses

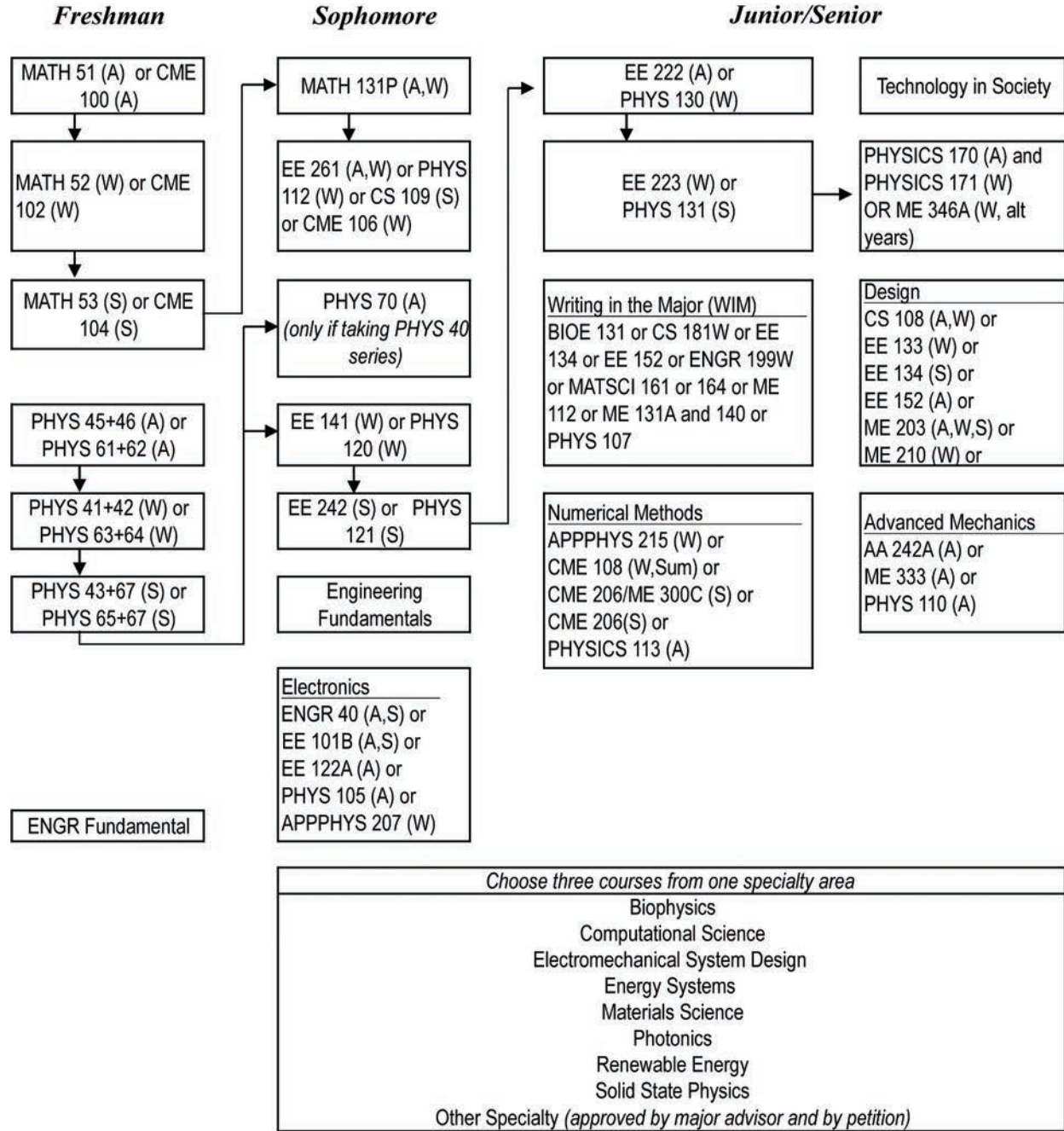

Engineering Physics

Biophysics Specialty Area

	<i>Fall</i>			<i>Winter</i>			<i>Spring</i>		
	Class	Math/ Sci	Engr	Class	Math/ Sci	Engr	Class	Math/ Sci	Engr
<i>Freshman</i>	MATH 51*	5		MATH 52	5		MATH 53	5	
	PHYS 45/46**	5		PHYS 41/42	5		PHYS 43/67	6	
							BIOE 80		4
	<i>Subtotals</i>	10	0	<i>Subtotals</i>	10	0	<i>Subtotals</i>	11	4
	Total	10		Total	10		Total	15	
<i>Sophomore</i>	CHEM 31X	5		BIOE 41		4	BIOE 42		4
	PHYS 70	4		MATH 131P	3		ENGR 40		3
	CS 106		5	PHYSICS 120	4		PHYSICS 121	4	
	<i>Subtotals</i>	9	5	<i>Subtotals</i>	7	4	<i>Subtotals</i>	4	7
	Total	14		Total	11		Total	11	
<i>Junior</i>	BIOE 44 (Depth)		4	BIOE 123 (Design)		4	EE 169 (Depth)		3
	PHYS 113	4		EE 261		3			
	<i>Subtotals</i>	4	4	<i>Subtotals</i>	0	7	<i>Subtotals</i>	0	3
	Total	8		Total	7		Total	3	
<i>Senior</i>	EE 222		3	EE 223		3	BIO 132 (Depth)	4	
	ME 333		3				BIOE 131 (WIM)		3
	<i>Subtotals</i>	0	6	<i>Subtotals</i>	0	3	<i>Subtotals</i>	4	3
	Total	6		Total	3		Total	7	

Total Math/Sci Units: 58
Total Engr: 46
Total Math/Sci/Engr: **104**

* In the Freshman year, students can take the CME 100 series rather than the Math 50 series.

** Students who have had strong physics preparation in high school (such as a score of at least 4 on the AP Physics C exam) may start the PHYSICS 40 sequence with PHYSICS 45 in Autumn Quarter; otherwise, students should start with PHYSICS 41 in the Winter Quarter. If a student has a very strong background in math and physics from high school (such as scores of 5 in AP Calc BC and AP Physics C exams), they can take the Physics 60 series rather than the Physics 40 series, in which case they do not take Physics 70 in the Sophomore year. Beginning 2011/12, students are required to take Phys 42 or 62 (mechanics lab).

➔ The School of ENGR encourages a quarter abroad. For detail on in-person or online ENGR course options see the Overseas Programs & Engineers page on the UGHB website or Chap 8 of the UGHB.

Engineering Physics

Computational Science Specialty Area

	<i>Fall</i>			<i>Winter</i>			<i>Spring</i>		
	Class	Math/ Sci	Engr	Class	Math/ Sci	Engr	Class	Math/ Sci	Engr
<i>Freshman</i>	MATH 51*	5		MATH 52	5		MATH 53	5	
	PHYS 45/46**	5		PHYS 41/42	5		PHYS 43/67	6	
	CS 106		5						
	<i>Subtotals</i>	<i>10</i>	<i>5</i>	<i>Subtotals</i>	<i>10</i>	<i>0</i>	<i>Subtotals</i>	<i>11</i>	<i>0</i>
	Total	15		Total	10		Total	11	
<i>Sophomore</i>	MATH 131P	3		PHYS 120	4		PHYS 121	4	
	PHYS 70	4		PHYS 112	4		CS 109		5
				CS 103 (Depth)		5	CS 109L		1
	<i>Subtotals</i>	<i>7</i>	<i>0</i>	<i>Subtotals</i>	<i>8</i>	<i>5</i>	<i>Subtotals</i>	<i>4</i>	<i>6</i>
	Total	7		Total	13		Total	10	
<i>Junior</i>	PHYS 113	4		CS 108 (Design)	4		CS 161 (Depth)		5
	EE 222		3	EE 223		3	ENGR 40		3
	<i>Subtotals</i>	<i>4</i>	<i>3</i>	<i>Subtotals</i>	<i>0</i>	<i>7</i>	<i>Subtotals</i>	<i>0</i>	<i>8</i>
	Total	7		Total	7		Total	8	
<i>Senior</i>	PHYS 170	4		PHYS 171	4		CS 181W (WIM)		4
	CS 221 (Depth)		4						
	ME 333		3						
	<i>Subtotals</i>	<i>4</i>	<i>7</i>	<i>Subtotals</i>	<i>4</i>	<i>0</i>	<i>Subtotals</i>	<i>0</i>	<i>4</i>
Total	11		Total	4		Total	4		

Total Math/Sci Units: **62**
Engineering Units: **45**
Third Engr Fund **3** (in addition to ENGR 40 and CS 106 already listed above)
Total Engr: **48**
Total Math/Sci/Engr: 110

* In the Freshman year, students can take the CME 100 series rather than the Math 50 series.

** Students who have had strong physics preparation in high school (such as a score of at least 4 on the AP Physics C exam) may start the PHYSICS 40 sequence with PHYSICS 45 in Autumn Quarter; otherwise, students should start with PHYSICS 41 in the Winter Quarter. If a student has a very strong background in math and physics from high school (such as scores of 5 in AP Calc BC and AP Physics C exams), they can take the Physics 60 series rather than the Physics 40 series, in which case they do not take Physics 70 in the Sophomore year. Beginning 2011/12, students are required to take Phys 42 or 62 (mechanics lab).

➔ The School of ENGR encourages a quarter abroad. For detail on in-person or online ENGR course options see the Overseas Programs & Engineers page on the UGHB website or Chap 8 of the UGHB.

Engineering Physics

Electromechanical System Design Specialty Area

	<i>Fall</i>			<i>Winter</i>			<i>Spring</i>		
	Class	Math/ Sci	Engr	Class	Math/ Sci	Engr	Class	Math/ Sci	Engr
<i>Freshman</i>	MATH 51*	5		MATH 52	5		MATH 53	5	
	PHYS 45/46**	5		PHYS 41/42	5		PHYS 43/67	6	
	<i>Subtotals</i>	10	0	<i>Subtotals</i>	10	0	<i>Subtotals</i>	11	0
	Total	10		Total	10		Total	11	
<i>Sophomore</i>	MATH 131P	3		PHYS 112	4		ENGR 40		3
	PHYS 70	4		CS 106		5	ME 80 (Depth)		4
				EE 241		3	EE 242		3
	<i>Subtotals</i>	7	0	<i>Subtotals</i>	4	8	<i>Subtotals</i>	0	7
	Total	7		Total	12		Total	7	
<i>Junior</i>	ME 101		3	ME 112 (Depth, WIM)		4	ME 203 (Design)		3
	ME 333		3				ME 103D		1
	PHYS 113	4							
	<i>Subtotals</i>	4	6	<i>Subtotals</i>	0	4	<i>Subtotals</i>	0	4
	Total	10		Total	4		Total	4	
<i>Senior</i>	EE 222		3	EE 223		3			
	PHYS 170	4		PHYS 171	4				
				ME 210 (Depth)		4			
	<i>Subtotals</i>	4	3	<i>Subtotals</i>	4	7	<i>Subtotals</i>	0	0
	Total	7		Total	11		Total	0	

Total Math/Sci Units: **54**
Engineering Units: **43**
Third Engr Fund **3** (in addition to ENGR 40 and CS 106 already listed above)
Total Engr: **46**
Total Math/Sci/Engr: **100**

* In the Freshman year, students can take the CME 100 series rather than the Math 50 series.

** Students who have had strong physics preparation in high school (such as a score of at least 4 on the AP Physics C exam) may start the PHYSICS 40 sequence with PHYSICS 45 in Autumn Quarter; otherwise, students should start with PHYSICS 41 in the Winter Quarter. If a student has a very strong background in math and physics from high school (such as scores of 5 in AP Calc BC and AP Physics C exams), they can take the Physics 60 series rather than the Physics 40 series, in which case they do not take Physics 70 in the Sophomore year. Beginning 2011/12, students are required to take Phys 42 or 62 (mechanics lab).

➔ The School of ENGR encourages a quarter abroad. For detail on in-person or online ENGR course options see the Overseas Programs & Engineers page on the UGHB website or Chap 8 of the UGHB.

Engineering Physics

Energy Systems Specialty Area

	<i>Fall</i>			<i>Winter</i>			<i>Spring</i>		
	Class	Math/ Sci	Engr	Class	Math/ Sci	Engr	Class	Math/ Sci	Engr
<i>Freshman</i>	MATH 51*	5		MATH 52	5		MATH 53	5	
	PHYS 45/46**	5		PHYS 41/42	5		PHYS 43/67	6	
	<i>Subtotals</i>	<i>10</i>	<i>0</i>	<i>Subtotals</i>	<i>10</i>	<i>0</i>	<i>Subtotals</i>	<i>11</i>	<i>0</i>
	Total	10		Total	10		Total	11	
<i>Sophomore</i>	MATH 131P	3		PHYS 112	4		ENGR 40		3
	PHYS 70	4		CS 106		5	ME 70		3
				EE 141		3	EE 242		3
	<i>Subtotals</i>	<i>7</i>	<i>0</i>	<i>Subtotals</i>	<i>4</i>	<i>8</i>	<i>Subtotals</i>	<i>0</i>	<i>9</i>
Total	7		Total	12		Total	9		
<i>Junior</i>	ME 101		3	ME 131B (Depth)		4	ME 140 (Depth, WIM)		5
	ME 333		3	ME 103D		1			
	ME 131A (Depth, WIM)		3						
	<i>Subtotals</i>	<i>0</i>	<i>9</i>	<i>Subtotals</i>	<i>0</i>	<i>5</i>	<i>Subtotals</i>	<i>0</i>	<i>5</i>
Total	9		Total	5		Total	5		
<i>Senior</i>	EE 222		3	EE 223		3			
	PHYS 170	4		PHYS 171	4				
	PHYS 113	4		ME 210 (Design)		4			
	<i>Subtotals</i>	<i>8</i>	<i>3</i>	<i>Subtotals</i>	<i>4</i>	<i>7</i>	<i>Subtotals</i>	<i>0</i>	<i>0</i>
Total	11		Total	11		Total	0		

Total Math/Sci Units: 54
Engineering Units: 50
Third Engr Fund 3 (in addition to ENGR 40 and CS 106 already listed above)
Total Engr: **53**
Total Math/Sci/Engr: **107**

* In the Freshman year, students can take the CME 100 series rather than the Math 50 series.
 ** Students who have had strong physics preparation in high school (such as a score of at least 4 on the AP Physics C exam) may start the PHYSICS 40 sequence with PHYSICS 45 in Autumn Quarter; otherwise, students should start with PHYSICS 41 in the Winter Quarter. If a student has a very strong background in math and physics from high school (such as scores of 5 in AP Calc BC and AP Physics C exams), they can take the Physics 60 series rather than the Physics 40 series, in which case they do not take Physics 70 in the Sophomore year. Beginning 2011/12, students are required to take Phys 42 or 62 (mechanics lab).

➔ The School of ENGR encourages a quarter abroad. For detail on in-person or online ENGR course options see the Overseas Programs & Engineers page on the UGHB website or Chap 8 of the UGHB.

Engineering Physics

Materials Science Specialty Area

	<i>Fall</i>			<i>Winter</i>			<i>Spring</i>		
	Class	Math/ Sci	Engr	Class	Math/ Sci	Engr	Class	Math/ Sci	Engr
<i>Freshman</i>	MATH 51*	5		MATH 52	5		MATH 53	5	
	PHYS 45/46**	5		PHYS 41/42	5		PHYS 43/67	6	
	<i>Subtotals</i>	10	0	<i>Subtotals</i>	10	0	<i>Subtotals</i>	11	0
	Total	10		Total	10		Total	11	
<i>Sophomore</i>	ENGR 31		4	ENGR 50		4	ENGR 40		3
	PHYS 70	4		MATH 131P	3		MATSCI 152 (Depth)	3	
				EE 141		3	EE 242		3
	<i>Subtotals</i>	4	4	<i>Subtotals</i>	3	7	<i>Subtotals</i>	0	9
	Total	8		Total	10		Total	9	
<i>Junior</i>	EE 222		3	EE 223		3	MATSCI 199 (Depth)		3
	PHYS 113	4		EE 261		3	CS 106		5
	<i>Subtotals</i>	4	3	<i>Subtotals</i>	0	6	<i>Subtotals</i>	0	8
	Total	7		Total	6		Total	8	
<i>Senior</i>	MATSCI 193 (Depth)		4	MATSCI 161(WIM)		4	PHYS 108	4	
	PHYS 170	4		PHYS 171	4		(Design)		
	PHYS 110	4							
	<i>Subtotals</i>	8	4	<i>Subtotals</i>	4	4	<i>Subtotals</i>	4	0
	Total	12		Total	8		Total	4	

Total Math/Sci Units: 58
Total Engr: 44
Total Math/Sci/Engr: 103

* In the Freshman year, students can take the CME 100 series rather than the Math 50 series.

** Students who have had strong physics preparation in high school (such as a score of at least 4 on the AP Physics C exam) may start the PHYSICS 40 sequence with PHYSICS 45 in Autumn Quarter; otherwise, students should start with PHYSICS 41 in the Winter Quarter. If a student has a very strong background in math and physics from high school (such as scores of 5 in AP Calc BC and AP Physics C exams), they can take the Physics 60 series rather than the Physics 40 series, in which case they do not take Physics 70 in the Sophomore year. Beginning 2011/12, students are required to take Phys 42 or 62 (mechanics lab).

➔ The School of ENGR encourages a quarter abroad. For detail on in-person or online ENGR course options see the Overseas Programs & Engineers page on the UGHB website or Chap 8 of the UGHB.

Engineering Physics

Photonics Specialty Area

	<i>Fall</i>			<i>Winter</i>			<i>Spring</i>		
	Class	Math/ Sci	Engr	Class	Math/ Sci	Engr	Class	Math/ Sci	Engr
<i>Freshman</i>	MATH 51*	5		MATH 52	5		MATH 53	5	
	PHYS 45/46**	5		PHYS 41/42	5		PHYS 43/67	6	
	<i>Subtotals</i>	<i>10</i>	<i>0</i>	<i>Subtotals</i>	<i>10</i>	<i>0</i>	<i>Subtotals</i>	<i>11</i>	<i>0</i>
	Total	10		Total	10		Total	11	
<i>Sophomore</i>	MATH 131P	3		EE 261		3	ENGR 40		3
	PHYS 70	4		EE 141		3	CS 106B or X		5
	<i>Subtotals</i>	<i>7</i>	<i>0</i>	<i>Subtotals</i>	<i>0</i>	<i>6</i>	EE 242		3
	Total	7		Total	6		Total	11	
<i>Junior</i>	EE 222		3	EE 223		3	MATSCI 199		3
	PHYS 113	4		PHYS 107(WIM)	4		(Depth)		
	<i>Subtotals</i>	<i>4</i>	<i>3</i>	EE 101A		4	EE101B		4
	Total	7		Total	11		Total	7	
<i>Senior</i>	EE 231 (Depth)		3	EE 134(Design)		4			
	PHYS 170	4		PHYS 171	4				
	ME 333		3	EE 243(Depth)		3			
	Total	10		Total	11		Total	0	

Total Math/Sci Units: 54
Engineering Units: 48
Third Engr Fund 3 (in addition to ENGR 40 and CS 106 already listed above)
Total Engr: 51
Total Math/Sci/Engr: 105

* In the Freshman year, students can take the CME 100 series rather than the Math 50 series.

** Students who have had strong physics preparation in high school (such as a score of at least 4 on the AP Physics C exam) may start the PHYSICS 40 sequence with PHYSICS 45 in Autumn Quarter; otherwise, students should start with PHYSICS 41 in the Winter Quarter. If a student has a very strong background in math and physics from high school (such as scores of 5 in AP Calc BC and AP Physics C exams), they can take the Physics 60 series rather than the Physics 40 series, in which case they do not take Physics 70 in the Sophomore year. Beginning 2011/12, students are required to take Phys 42 or 62 (mechanics lab).

➔ The School of ENGR encourages a quarter abroad. For detail on in-person or online ENGR course options see the Overseas Programs & Engineers page on the UGHB website or Chap 8 of the UGHB.

Engineering Physics

Solid State Physics Specialty Area

	<i>Fall</i>			<i>Winter</i>			<i>Spring</i>		
	Class	Math/ Sci	Engr	Class	Math/ Sci	Engr	Class	Math/ Sci	Engr
<i>Freshman</i>	MATH 51*	5		MATH 52	5		MATH 53	5	
	PHYS 45/46**	5		PHYS 41/42	5		PHYS 43/67	6	
	<i>Subtotals</i>	<i>10</i>	<i>0</i>	<i>Subtotals</i>	<i>10</i>	<i>0</i>	<i>Subtotals</i>	<i>11</i>	<i>0</i>
	Total	10		Total	10		Total	11	
<i>Sophomore</i>	MATH 131P	3		EE 261		3	ENGR 40		3
	PHYS 70	4		EE 141		3	CS 106		5
							EE 242		3
	<i>Subtotals</i>	<i>7</i>	<i>0</i>	<i>Subtotals</i>	<i>0</i>	<i>6</i>	<i>Subtotals</i>	<i>0</i>	<i>11</i>
	Total	7		Total	6		Total	11	
<i>Junior</i>	EE 222		3	EE 223		3	EE 116 (Depth)		3
				EE 101A		4	EE 101B		4
	<i>Subtotals</i>	<i>0</i>	<i>3</i>	<i>Subtotals</i>	<i>0</i>	<i>7</i>	<i>Subtotals</i>	<i>0</i>	<i>7</i>
	Total	3		Total	7		Total	7	
<i>Senior</i>	PHYS 110	4		EE 133(Design)		3	EE 237(Depth)		3
	PHYS 113	4		EE 236(Depth)		3	MATSCI 161		4
	PHYS 170	4		PHYS 171	4				
	<i>Subtotals</i>	<i>12</i>	<i>0</i>	<i>Subtotals</i>	<i>4</i>	<i>6</i>	<i>Subtotals</i>	<i>0</i>	<i>7</i>
	Total	12		Total	10		Total	7	

Total Math/Sci Units: 54

Engineering Units: 47

Third Engr Fund 3 (in addition to ENGR 40 and CS 106 already listed above)

Total Engr: **50**

Total Math/Sci/Engr: **104**

* In the Freshman year, students can take the CME 100 series rather than the Math 50 series.

** Students who have had strong physics preparation in high school (such as a score of at least 4 on the AP Physics C exam) may start the PHYSICS 40 sequence with PHYSICS 45 in Autumn Quarter; otherwise, students should start with PHYSICS 41 in the Winter Quarter. If a student has a very strong background in math and physics from high school (such as scores of 5 in AP Calc BC and AP Physics C exams), they can take the Physics 60 series rather than the Physics 40 series, in which case they do not take Physics 70 in the Sophomore year. Beginning 2011/12, students are required to take Phys 42 or 62 (mechanics lab).

➔ The School of ENGR encourages a quarter abroad. For detail on in-person or online ENGR course options see the Overseas Programs & Engineers page on the UGHB website or Chap 8 of the UGHB.

Engineering Physics

Renewable Energy Specialty Area

	<i>Fall</i>			<i>Winter</i>			<i>Spring</i>		
	Class	Math/ Sci	Engr	Class	Math/ Sci	Engr	Class	Math/ Sci	Engr
<i>Freshman</i>	MATH 51*	5		MATH 52	5		MATH 53	5	
	PHYS 45/46**	5		PHYS 41/42	5		PHYS 43/67	6	
	<i>Subtotals</i>	10	0	<i>Subtotals</i>	10	0	<i>Subtotals</i>	11	0
	Total	10		Total	10		Total	11	
<i>Sophomore</i>	MATH 131P	3		PHYS 112	4		ENGR 40		3
	PHYS 70	4		ENGR 50		4	EE 242		3
				EE 141		3			
	<i>Subtotals</i>	7	0	<i>Subtotals</i>	4	7	<i>Subtotals</i>	0	6
	Total	7		Total	11		Total	6	
<i>Junior</i>	EE222		3	EE223		3	CS106BorX		5
	MATSCI 156 (Depth)		4	CME108		4	MATSCI 152(WIM)		4
	<i>Subtotals</i>	0	7	<i>Subtotals</i>	0	7	<i>Subtotals</i>	0	9
	Total	7		Total	7		Total	9	
<i>Senior</i>	PHYS 170	4		PHYS 171	4				
	EE 293A (Depth)		3	EE 293B (Depth)		3			
	ME 333		3	ME 210 (Design)		4			
	<i>Subtotals</i>	4	6	<i>Subtotals</i>	4	7	<i>Subtotals</i>	0	0
	Total	10		Total	11		Total	0	

Total Math/Sci Units: 50

Total Engr: 49

Total Math/Sci/Engr: 99

* In the Freshman year, students can take the CME 100 series rather than the Math 50 series.

** Students who have had strong physics preparation in high school (such as a score of at least 4 on the AP Physics C exam) may start the PHYSICS 40 sequence with PHYSICS 45 in Autumn Quarter; otherwise, students should start with PHYSICS 41 in the Winter Quarter. If a student has a very strong background in math and physics from high school (such as scores of 5 in AP Calc BC and AP Physics C exams), they can take the Physics 60 series rather than the Physics 40 series, in which case they do not take Physics 70 in the Sophomore year. Beginning 2011/12, students are required to take Phys 42 or 62 (mechanics lab).

➔ The School of ENGR encourages a quarter abroad. For detail on in-person or online ENGR course options see the Overseas Programs & Engineers page on the UGHB website or Chap 8 of the UGHB.

INSTRUCTIONS FOR DECLARING A MAJOR IN ENGINEERING: ENGINEERING PHYSICS (ENGR-BS: EPHYS)

1. Make a pre-major advising appointment with either Prof. Pat Burchat at **burchat@stanford.edu** in Physics, or with Prof Mark Cappelli at **cap@stanford.edu** in Mechanical Engineering, to discuss math and physics requirements, the selection of a specialty in Engineering Physics, and choosing an advisor.
2. Declare the Engineering Physics subplan on Axess: **select "Engineering" as your major and "Engineering Physics" as your subplan.**
3. Send an email notice to Darlene Lazar at **dlazar@stanford.edu**. In your email, indicate a preference for a major advisor, if any.
4. Print your unofficial Stanford transcript from Axess.
5. Download the Engineering Physics Program Sheet from the School of Engineering web site at **http://ughb.stanford.edu**. Complete the Program Sheet, indicating how you plan to fulfill the major requirements (or do this when you meet with your advisor).
6. Make an appointment with your advisor to discuss your program. Have your advisor sign the Program Sheet. Your program proposal may change as you progress in the program; submit revisions in consultation with your advisor. **(Submit an initial Program Sheet during the quarter in which you declare, and a final Program Sheet at least two quarters before you graduate.)**
7. Return your signed Program Sheet, unofficial transcript, and plan to Darlene in 135 Huang. She can also approve AP credit or assist in transferring credit, if applicable, as well as give you an official School of Engineering t-shirt for declaring.

Note: The online version of your major (link from the Home or Major Programs page of the UGHB website) is considered the definitive version of 2014-15 requirements; corrections or updates may have been made after the printed and pdf versions were published in August 2014.

★ You must use a program sheet from a year you have been enrolled at Stanford.

Stanford University ♦ School of Engineering
Engineering Physics
2014–2015 Program Sheet
Specialty Area _____**

Follow all requirements as stated for the year of the program sheet used.

Name: _____ SU ID #: _____
 Phone: _____ Email: _____
 Today's Date: _____ Month/Yr B.S. expected: _____

Mathematics and Science Requirements

Dept	Course	Title	Transfer/AP Approval		Units	Grade
			✓ if Transfer	Initials Date		
<i>Mathematics (18 units)</i>						
MATH or CME	51 or 100				5	
MATH or CME	52 or 104				5	
MATH or CME	53 or 102				5	
MATH	131P	Partial Differential Equations I			3	
<i>Mathematics Unit Total</i>					18	
<i>Science (15 units minimum)</i>						
PHYS	41+42 or 61+62	Mechanics and lab (required)			5	
PHYS	43+67 or 63+64	Electricity and Magnetism plus lab (required)			5	
PHYS	45+46 or 65+67	Light and Heat plus lab (required)			5 or 6	
PHYS	70	See note 1			4	
		See note 2 on other recommendations				
<i>SOE Science Unit Total</i>						
<i>Mathematics and Science Total</i>						

Technology in Society Requirement (one course required; see UGHB, Fig. 3-3 for SoE approved list)

	3 to 5
--	---------------

Engineering Fundamentals (three courses minimum; CS 106A, B, or X recommended; use only 1 CS course)

<i>Engineering Fundamentals Total (3 courses required)</i>	

NOTES

- * **All courses taken for the major must be taken for a letter grade if that option is offered by the instructor.**
 - * This form is available as an Excel file at <http://ughb.stanford.edu/>; you must use a program sheet from a year you are enrolled at Stanford. The printed form must be signed by the advisor. Changes must be initialed in ink.
 - * Read all emails from your major department; this is the SoE's only method of conveying key information to Eng majors.
 - * Minimum Grade Point Average (GPA) for all courses in Engineering Topics (Fundamentals and Depth combined) is 2.0.
 - * Transfer and AP credits in Math, Science, Funds., & TIS must be approved by the SoE Dean's Office. Transfer credits in Engineering Depth must be approved by the Advisor. Transfer credit information and petitions are available at <http://ughb.stanford.edu/>
 - * Units for any course listed on this form must appear under only one category. Delete courses/units not taken.
 - ** Choose from the following Specialties: Biophysics, Computational Science, Electromechanical System Design, Energy Systems, Materials Science, Photonics, Renewable Energy, Solid State Physics, or Individually Designed (consult with advisor). You may change your specialty area at any time in consultation with your advisor.
- (1) This course required only if taking the Physics 40 series (omit if taking Physics 60 series).
- (2) PHYSICS 42 or 62 required beginning 2011/12. PHYSICS 67 recommended in place of 44 for students taking the 40 series.

Engineering Physics Depth

Specialty Area (Circle one): BioPhys ComptlSci Electromech EngSys MatSci Photonics RenEng SolState IndivDes

Dept	Course	Title	Transfer/AP Approval			Units		Grade
			✓ if Transfer	Initials	Date	Eng	Phys	
		Advanced Mathematics; one elective (see note 3)				3-4	3-4	
PHYS	110	Advanced Mechanics or Dynamics (see note 4)				3	4	
EE or PHYS	141 or 120	Int. Electricity & Magnetism				3	4	
EE or PHYS	242 or 121	Electromagnetic Waves				3	4	
APPPHYS	215	Numerical Meth Phys & Engrs (see note 5)				3-4	3-4	
ENGR	40	Intro to Electronics (see note 6)				5	3	
ENGR	199W	Writing of Original Research for Engineers (WIM; see note 7)				4-5	4	
EE	222	Applied Quantum Mechanics I (see note 8)				3	4	
EE	223	Applied Quantum Mechanics II (see note 8)				3	4	
PHYS	170	Thermodynamics, Kinetic Theory, & Stat. Mech. (see note 9)				0	4	
PHYS	171	Thermodynamics, Kinetic Theory, & Stat. Mech. (see note 9)				0	4	
		Design course; choose one (see note 10)				3-4	3	
Specialty Area is:								
Choose three courses from one specialty area:								
						9-12	9-12	
<i>Engineering and Physics Depth Total</i>								

Program Totals

Math + Science + Physics Depth (45 units minimum) _____
Engineering (Fundamentals + Depth + Electives) Units (45 units minimum in SoE) _____

NOTES (continued from page 1)

- (3) Recommended courses are EE 261, PHYSICS 112, CS 109, CME 106. Also qualified are EE263, any Math or Statistics course numbered 100 or above, and any CME course numbered 200 or above, except CME 206.
- (4) Alternative approved courses are AA 242A or ME 333.
- (5) Alternative approved courses are CME 108, CME 206/ME 300C or PHYS 113.
- (6) Alternative approved courses are EE 101B, EE 122A, PHYSICS 105 or APPPHYS 207. ENGR 40A does not satisfy requirement.
- (7) Alternative approved WIM courses are BIOE 131, CS 181W, EE 134, EE 152, MATSCI 161, MATSCI 164, ME 112, ME 131A and 140, or PHYSICS 107.
- (8) Alternative approved courses are PHYS 130 and 131.
- (9) Alternative approved course is ME 346A (offered alternate years).
- (10) Approved design courses are CS 108, EE 133, EE 134, EE 152, ME203, ME 210 and PHYSICS 108.

Program Approvals

Advisor

Printed Name: _____
 Signature: _____

Date: _____

Departmental

Printed Name: _____
 Signature: _____

Date: _____

School of Engineering (No action required -- office use only)

Printed Name: _____
 Signature: _____

Date: _____

ENVIRONMENTAL ENGINEERING

— ABET ACCREDITED FOR B.S. DEGREES CONFERRED BY JUNE 2015* —

The Civil and Environmental Engineering Department is no longer accepting new declarations for the undergraduate major in Environmental Engineering. Current Environmental Engineering majors should refer to the 2013-2014 Handbook for Undergraduate Engineering Programs for degree requirements for the Environmental Engineering major. ABET accreditation for the Environmental Engineering degree will cease after June 2015.

For undergraduates interested in Environmental Engineering, two options are available:

- 1) The undergraduate Civil Engineering major (which is ABET-accredited) offers an Environmental & Water Studies track, with a curriculum quite similar to the Environmental Engineering major.
- 2) A new major in Environmental Systems Engineering (which is not ABET-accredited) offers a choice of focusing on coastal environments, freshwater environments, or urban environments.

ENVIRONMENTAL SYSTEMS ENGINEERING

For civil and environmental engineering in the 21st Century, engineers must be equipped to be adaptable, ready to take on new, complex challenges involving natural and built environments.

The Environmental Systems Engineering major is designed to prepare students for incorporating environmentally sustainable design, strategies and practices into natural and built systems and infrastructure involving buildings, water supply, and coastal regions.

THE CURRICULUM

The undergraduate Environmental Systems Engineering major provides the math, science, engineering fundamentals, and tools and skills considered essential for an engineer, along with a choice of 3 focus areas for more in-depth study, including a capstone experience. Focus areas are:

- ***Urban Environments:*** Focus is on sustainability in the constructed urban environment, ranging from building-scale to urban-scale issues. Considerations include sustainable design and construction practices, energy technologies, water supply systems, and urban planning.
 - ***Freshwater Environments:*** Focus is on incorporating sustainability into the design, management, and protection of water supply systems. Study areas include water resources, water treatment processes, aquatic chemistry and biology, and design principles for urban waterways.
 - ***Coastal Environments:*** Focus is on the impacts of urban areas on coastal waters, and vice versa. Study areas include physical oceanography, biological and chemical processes and contaminants in the marine environment, and issues in coastal planning and policy.
- ➔ Those undergraduates potentially interested in the Environmental Systems Engineering major should examine the Civil Engineering major as a possible alternative; a comparison of these two majors is presented on the next page.

For more information on the Civil & Environmental Systems Engineering major, please contact Jill Filice in Room 316 of the Yang and Yamazaki Environment & Energy (Y2E2) building.

A COMPARISON: ENVIRONMENTAL SYSTEMS ENGINEERING VS. CIVIL ENGINEERING

Students interested in the area of civil and environmental engineering should be aware of the following differences between choosing this Environmental Systems Engineering major versus the Civil Engineering major:

Professional Considerations: The Civil Engineering degree is ABET-accredited, while the Environmental Systems Engineering major is not. An ABET-accredited degree is a first step toward a professional engineering license. In California, you must accrue 6 years of work experience under the supervision of a licensed professional engineer before being allowed to take the licensing exam. An ABET-accredited B.S. degree counts as 4 years of this required work experience.

➔ If you envision a career providing, supervising or managing professional engineering services (e.g. engineering investigations, design), you will likely need to become a licensed professional engineer and should consider a degree accredited by ABET (Accreditation Board for Engineering and Technology).

Pragmatic Considerations: The Civil Engineering major provides a structured curriculum that ensures breadth across different areas specified by ABET. The Environmental Systems Engineering major offers more flexibility in choosing courses, and the ability to focus on a specific topic area.

RESEARCH EXPERIENCE FOR UNDERGRADUATES

The department of Civil and Environmental Engineering welcomes student participation in the VPUE undergraduate research programs. Interested students should check the [VPUE website](#) and the [CEE website](#) for announcements regarding the application procedures. Program announcements typically appear in January with application due dates in February.

2014-15 EnvSE Major Requirements

MATHEMATICS AND SCIENCE: 36 UNITS MINIMUM, INCLUDING:

Course	Title	Units	Qtr.
MATH 41/42	Calculus (or 10 units AP Calculus, or Math 19/20/21)	10	A/A,W
MATH 51	Linear Algebra/Diff. Calculus of Several Variables (or CME 100)	5	A,W,S
Additional Math	Either MATH 53, CME 102, or Prob./Statistics course from Fig 3-1)	3-5	A,W,S
PHYSICS 41	Mechanics	4	W
CHEM 31B or 31X	Chemical Principles (or ENGR 31, 4 units, Aut) (for Urban track only can sub PHYSICS 43 – 4 units, Spr qtr)	5	W or A
Addl.SoE-approved Sci./Math electives	[from lists in Chapter 3, Figures 3-1 and 3-2; may include CHEM 31A]	7-10	

TECHNOLOGY IN SOCIETY (TIS): ONE 3-5 UNIT COURSE REQUIRED (SEE CHAP 3, FIG 3-3)

ENGINEERING FUNDAMENTALS: 3 COURSES MINIMUM

Course	Title	Units	Qtr.
ENGR 70A	Programming Methodology (req'd for all tracks)	5	A,W,S
ENGR 90 <i>or</i> CEE 146A*	(Req'd for Coastal, Freshwater tracks) Envir. Sci. & Technology <i>or</i> (Req'd for Urban track) Engineering Economy (or ENGR 60, Sum)	3	A,W,S W
Any 3 rd Eng. Fund.	[from list in Chapter 3, Figure 3-4; <u>cannot</u> count ENGR 70B or X]	3-5	

* CEE 146A may be counted as an Engineering Fundamental only for EnvSE and AD majors.

FUNDAMENTAL TOOLS/SKILLS: 10 UNITS REQ'D, INCLUDING CEE 1, AND ALL 3 CATEGORIES

	Course	Title	Units	Qtr.
→	CEE 1	Introduction to Environmental Systems Engineering (req'd)	1	S
(1) Visual Communication		One from CATEGORY 1:		
	CEE 31/31Q	Accessing Architecture thru Drawing (WAY-CE)	4	A,W,S
	CEE 133F	Principles of Freehand Drawing	3	W
	ME 101	Visual Thinking (WAY-CE)	4	A,W,S
	ME 110	Design Sketching	2	A,W,S
	ARTSTUDI 160	Design I: Fund. Visual Language (<i>limited enrollment</i>) (WAY-CE)	3-4	A,W,S
	OSPParis 44	Analytical Drawing & Graphic Art	2	A,W,S
(2) Oral / Written Communication		One from CATEGORY 2:		
	ENGR 103 <i>or</i> ORALCOM 122	Public Speaking <i>or</i> The Art and Heart of Effective Public Speaking (<i>alt years</i>)	3	A,W,S W
	ENGR 202W	Technical Writing	3	A,W,S
	CEE 151	Negotiation (<i>limited enrollment; application req'd</i>)	3	S
	EARTHSYS 195	Natural Hazards and Risk Communication (WIM)	3	S
	ENVRES 200	Research, Anal, Writ for Public (WIM) (<i>appl req'd</i>) (WIM; WAY-CE)	3	A,S
(3) Modeling / Analysis		One from CATEGORY 3:		
	CEE 155	Introduction to Sensing Networks	4	W
	CEE 120A or B	Building Information Modeling	2-4	A,W
	CEE 226	Life Cycle Assessment	3-4	A
	CEE 146A	Engineering Economy (or ENGR 60) (<i>if not counted as Eng.Fund.</i>)	3	W(or Sum)
	EARTHSYS 144	Fundamentals of GIS	3-4	A
	ENERGY 160	Modeling Uncertainty in the Earth Sciences	3	W
	CEE 101D	Computations in CEE (<i>if not counted as Math</i>) (or CEE101S)	3	A (or Sum)
	CME 211 <i>or</i> EARTHSYS 211	Intro.to Programming for Scientists and Engineers (Python, C++) <i>or</i> Fundamentals of Modeling (R programming)	3 3-5	A A

Writing in the Major (WIM) One 3-5 unit course required

Choose one from: COMM 120W, MS&E 193W, or MS&E 197 (TiS classes); or EARTHSYS 195 or ENVRES 200 (Tools/Skills); or CEE 100 (Urban focus/Breadth Elective)

Environmental Systems Engineering Depth: Choose one Focus Area

COASTAL ENVIRONMENTS FOCUS AREA (36 UNITS MINIMUM)

Course	Title	Units	Qtr.
Required: (10-11 units)			
CEE 101B	Mechanics of Fluids (req'd; prereq: PHYSICS 41)	4	S
CEE 164	Physical Oceanography (req'd; prereq: PHYSICS 41)	3	W
CEE 175A	California Coast: Science, Policy and Law (<i>alt years</i>)	3-4	S
Electives: (20-23 units); Choose from:			
(a) Focus Electives:			
CEE 129	Climate Change Adaptation for Coastal Cities: Engr/Policy for a Sust. Future	3	A
CEE 160	Fluid Mechanics Laboratory (co-req: CEE 101B)	2	S
CEE 166A	Watersheds & Wetlands (prereq: CEE 101B)	3	A
CEE 171	Environmental Planning Methods (CEE 70 recommended)	3	W
CEE 174A	Providing Safe Water for Developing/Developed World (prereq: CHEM 31B)	3	A
CEE 174B	Wastewater Trtmt.: Disposal to Resource Recovery (prereq: CEE174A)	3	W
CEE 177	Aquatic Chemistry and Biology (prereq: CHEM 31B)	4	A
CEE 272	Coastal Contaminants (prereqs: CEE 101B, 177) (<i>instructor consent req'd</i>)	3	A
BIO 30	Ecology for Everyone (<i>only if not counted as a Science</i>)	4	S
EARTHSYS 8 <i>or</i> GES 8	The Oceans: An Introduction to the Marine Environment (<i>alt years</i>) <i>or</i> Oceanography: An Introduction to the Marine Environment	3	S Sum
EARTHSYS 141	Remote Sensing of the Oceans	3-4	W
EARTHSYS 146B	Atmosphere, Ocean, and Climate Dynamics: Ocean Circulation	3	S
EARTHSYS 151 + EARTHSYS 152	Biological Oceanography (prereqs: BIO 43 or BIO 30; EESS 8) + Marine Chemistry (prereq: CHEM 31B) (<i>2 courses designed to be taken concurrently</i>)	3-4 + 3-4	S S
EARTHSYS 156M	Marine Resource Economics and Conservation (<i>alt. years</i>)	5	S
(b) Breadth Electives: can be relevant IntroSems ¹ <i>or</i> Overseas classes ² ; addl. Tools/Skills; addl. Engr. Funds.; or any required or focus elective courses from the other 2 EnvSE focus areas		up to 7 units	any
Capstone: (1 required, 3-5 units)			
CEE 141A	Infrastructure Project Development (CEE 171 recommended)	3	A
CEE 169 (<i>alt. yrs</i>)	Environ. & Water Resources Engr. Design (Prereq: CEE 166B)	5	S
CEE 179C (<i>alt. yrs</i>)	Environmental Engineering Design (Prereq: CEE174A)	5	S
CEE 199	Independent Research in CEE (<i>must petition CEE UG Committee for approval, prior to enrollment</i>).	3-5	(any)

1 Relevant IntroSems (offerings will vary from year to year):

BIO 3N (3,S): Views of a Changing Sea: Literature & Science

BIO 12N (3,A): Sensory Ecology of Marine Animals

CEE 50N (3,S): Perspectives on a Large Urban Estuary: San Francisco Bay (*alt years*)

EARTHSYS 46N (3,S): Critical Interface between Land & Monterey Bay: Elkhorn Slough

EARTHSYS 56Q (3,W): Changes in the Coastal Ocean: The View from Monterey and SF Bays

2 Relevant Overseas (and Off-Campus) classes (offerings will vary from year to year):

BIOHOPK 163H (4,W): Oceanic Biology (*alt years*)

BIOHOPK 172H (5,W): Marine Ecology (if BIO 30 is not used)
 OSPAUSTL 10 (3,A): Coral Reef Ecosystems
 OSPAUSTL 30 (3,A): Coastal Forest Ecosystems
 OSPSANTG 85 (5,S): Marine Ecology of Chile and the South Pacific

FRESHWATER ENVIRONMENTS FOCUS AREA (36 UNITS MINIMUM)

Course	Title	Units	Qtr.
Required (11 units)			
CEE 101B	Mechanics of Fluids (req'd; prereq: PHYSICS 41)	4	S
CEE 177	Aquatic Chemistry and Biology (req'd; prereq: CHEM 31B)	4	A
<u>One of:</u>			
CEE 166A	Watersheds & Wetlands (prereq: CEE 101B)	3	A
CEE 174A	Providing Safe Water for Developing/Developed World (prereq: CHEM 31B)	3	A
Electives (20-23 units); Choose from:			
(a) Focus Electives			
CEE 160	Mechanics of Fluids Laboratory (co-req: CEE 101B)	2	S
CEE 161A	Rivers, Streams, Canals (prereq: CEE 101B)	3-4	A
CEE 165C	Water Resources Management	3	Sum
CEE 166A	Watersheds & Wetlands (prereq: CEE101B) (<i>if not counted as Req'd course</i>)	3	A
CEE 166B	Floods & Droughts, Dams & Aqueducts (prereq: CEE 166A)	3	W
CEE 166D	Water Resources and Water Hazards Field Trips	2	W
CEE 171	Environmental Planning Methods (CEE 70 recommended)	3	W
CEE 174A	Providing Safe Water for Developing/Developed World (prereq: CHEM 31B) (<i>if not counted as Req'd course</i>)	3	A
CEE 174B	Wastewater Treatment.: Disposal to Resource Recovery (prereq: CEE 174A)	3	W
CEE 179A	Aquatic Chemistry Laboratory (CEE 177 recommended)	3	W
CEE 265A	Sustainable Water Resources Dev. (prereq: CEE 177; <i>limited enrollment</i>)	3	S
CEE 265D	Water and Sanitation in Developing Countries (<i>limited enrollment</i>)	3	S
EARTH SYS 140	The Energy-Water Nexus (<i>alt years</i>)	3	W
EARTH SYS 156	Soil & Water Chemistry (CHEM 31B/X, CEE177 recommended) (<i>alt years</i>)	4	W
GES 130	Soil Physics and Hydrology	3	A
(b) Breadth Electives: can be relevant IntroSems ¹ or Overseas classes ² ; addl. Tools/Skills; addl. Eng. Funds.; or any required or focus elective courses from the other 2 EnvSE focus areas		up to 7 units	any
Capstone: (1 required, 3-5 units)			
CEE 141A	Infrastructure Project Development (CEE 171 recommended)	3	A
CEE 169 (<i>alt. yrs</i>)	Environ. & Water Resources Engineering Design (Prereq: CEE 166B)	5	S
CEE179C (<i>alt. yrs</i>)	Environmental Engineering Design (Prereq: CEE 174A)	5	S
CEE 199	Independent Research in CEE (<i>must petition CEE UG Committee for approval prior to enrollment</i>) [can add 1 unit of Engr199W to satisfy WIM]	3-5	(any)

1 Relevant IntroSems (offerings will vary from year to year):

BIO 35N (3,W): Water: from Cadillac Deserts to Plant Physiology
 GES 43Q (3,W): Environmental Problems (focuses on groundwater, watersheds)
 CEE 29N (3,W): Managing Natural Disaster Risk (includes floods)
 CEE 50N (3,S): Perspectives on a Large Urban Estuary: San Francisco Bay (alt years)

2 Relevant Overseas classes (offerings will vary from year to year):

OSPAUSTL 25 (3,A): Freshwater Systems
 OSPAUSTL 30 (3,A): Coastal Forest Ecosystems
 OSPCPTWN 49 (4,S): Water in S. Africa: Human Right, Public Trust, or Market Commodity?
 OSPGEN 60 (2,Sum): Wetlands Ecol & Conservation: the Pantanal – A Case Study (prereq: EARTH SYS 115)
 OSPMADR 79 (4,A): Earth and Water Resources' Sustainability in Spain

URBAN ENVIRONMENTS FOCUS AREA (36 UNITS MINIMUM)

Course	Title	Units	Qtr.
Required (11-12 units):			
CEE 100	Managing Sustainable Building Projects (WIM)	4	A
CEE 101B	Mechanics of Fluids (req'd; prereq: PHYSICS 41)	4	S
CEE 176A	Energy Efficient Buildings	3-4	W
Electives: (19-22 units) Choose from:			
(a) Focus Electives			
(i) Building Systems			
CEE 102	Legal Aspects of Engineering and Construction	3	W
CEE 130	Architectural Design: 3-D Modeling, Method, Process (prereq: CEE 31/31Q)	4	A,S
CEE 156	Building Systems	4	W
(ii) Energy Systems			
CEE173A	Energy Resources (<i>or</i> CEE 107S, 3 units, Sum)	4-5	A
CEE 176B	Electric Power: Renewables and Efficiency (PHYSICS 43 rec.)	3-4	S
ENERGY 171 <i>or</i> ENERGY 191	Energy Infrastructure, Technology, and Economics (prereq: CEE 173A) <i>or</i> Optimization of Energy Systems (CS106A recommended)	3 3-4	A W
(iii) Water Systems			
CEE 166A	Watersheds & Wetlands (prereq: CEE 101B)	3	A
CEE 166B	Floods & Droughts, Dams & Aqueducts (prereq: CEE 166A)	3	W
CEE 174A	Providing Safe Water for Developing/Developed World (prereq: CHEM 31B)	3	A
CEE 174B	Wastewater Treatment: Disposal to Resource Recovery (prereq: CEE 174A)	3	W
(iv) Urban Planning			
CEE 171	Environmental Planning Methods	3	W
CEE 177L	Smart Cities and Communities	3	Sum
URBANST 107 <i>or</i> URBANST 113	Introduction to Urban and Regional Planning <i>or</i> Introduction to Urban Design: ...Theory and Practice (WAY-CE or SI)	3 5	W W
URBANST 164 <i>or</i> URBANST 165	Sustainable Cities <i>or</i> Sustain. Urban/Regional Transportation Planning (<i>alt. years</i>) (WAY-SI)	4-5 4-5	W A
(b) Breadth Electives: can be relevant IntroSems ¹ <i>or</i> Overseas classes ² ; addl. Tools/Skills; addl. Engr. Funds.; or any required or focus elective courses from the other 2 EnvSE focus areas		up to 7 units	any
Capstone: (1 required, 3-5 units)			
CEE 112A	Indust.Apps.of Virtual Design & Constr. (Prereqs: CEE100, 120A or B)	3-4	A
CEE 122A+B	Computer Integrated Architecture/Engineering/Construction (Prereq: CEE120A or 120B or 156) (<i>Instructor permission req'd.</i>)	2+2	W+S
CEE 141A	Infrastructure Project Development (CEE 102 or 171 recommended)	3	A
CEE 141B	Infrastructure Project Delivery (Co-reg: CEE 146A)	3	W
CEE 221A	Planning Tools/Meth. in Power Sector (Prereqs: CEE 146A,173A; MatLab)	3-4	W
CEE 226E	Adv. Topics in Integrated Energy-Efficient Bldg. Design (prereq: CEE156)	3	S
CEE 199	Independent Research in CEE (<i>must petition CEE UG Committee for approval, prior to enrollment</i>) [can add 1 unit of Engr199W to satisfy WIM]	3-5	(any)

¹ Relevant IntroSems (offerings will vary from year to year):

- AA 116Q (3,A): Electric Automobiles and Aircraft
- CEE 29N (3,W): Managing Natural Disaster Risk
- CEE 48N (3,W): Managing Complex, Global Projects
- CEE 50N (3,S): Perspectives on a Large Urban Estuary: San Francisco Bay (*alt years*)
- APPPHYS 79N (3,A): Energy Options for the 21st Century
- ECON 17N (3,W): Energy, the Environment, and the Economy [WAY-SI]

Continued on next page

ME 16N (3,A): Energy & the Industrial Revolution: Past, Present, and Future

2 Relevant Overseas classes (offerings will vary from year to year):

OSPBER 4 (3,S): Role of Technology in Modern Life
OSPBER 60 (5,A): Architecture & Urban Design in Berlin
OSPFLOR 58 (4,S): Space as History: Social Vision & Urban Change
OSPMADRD 8A (2,A): Architecture, Culture, and Nature in Madrid: Towards a Sustainable City
OSPPARIS 92 (4,S): Building Paris: Its History, Architecture and Urban Design
OSPSANTG 29 (4-5,S): Sustainable Cities: Comparative Transportation Systems
OSPSANTG 31 (5,Sum): The Chilean Energy System: 30 Years of Market Reforms
OSPSANTG 71(4-5,A,S): Santiago: Urban Planning, Public Policy, and the Built Environment

Environmental Systems Engineering

Typical Sequence of Courses

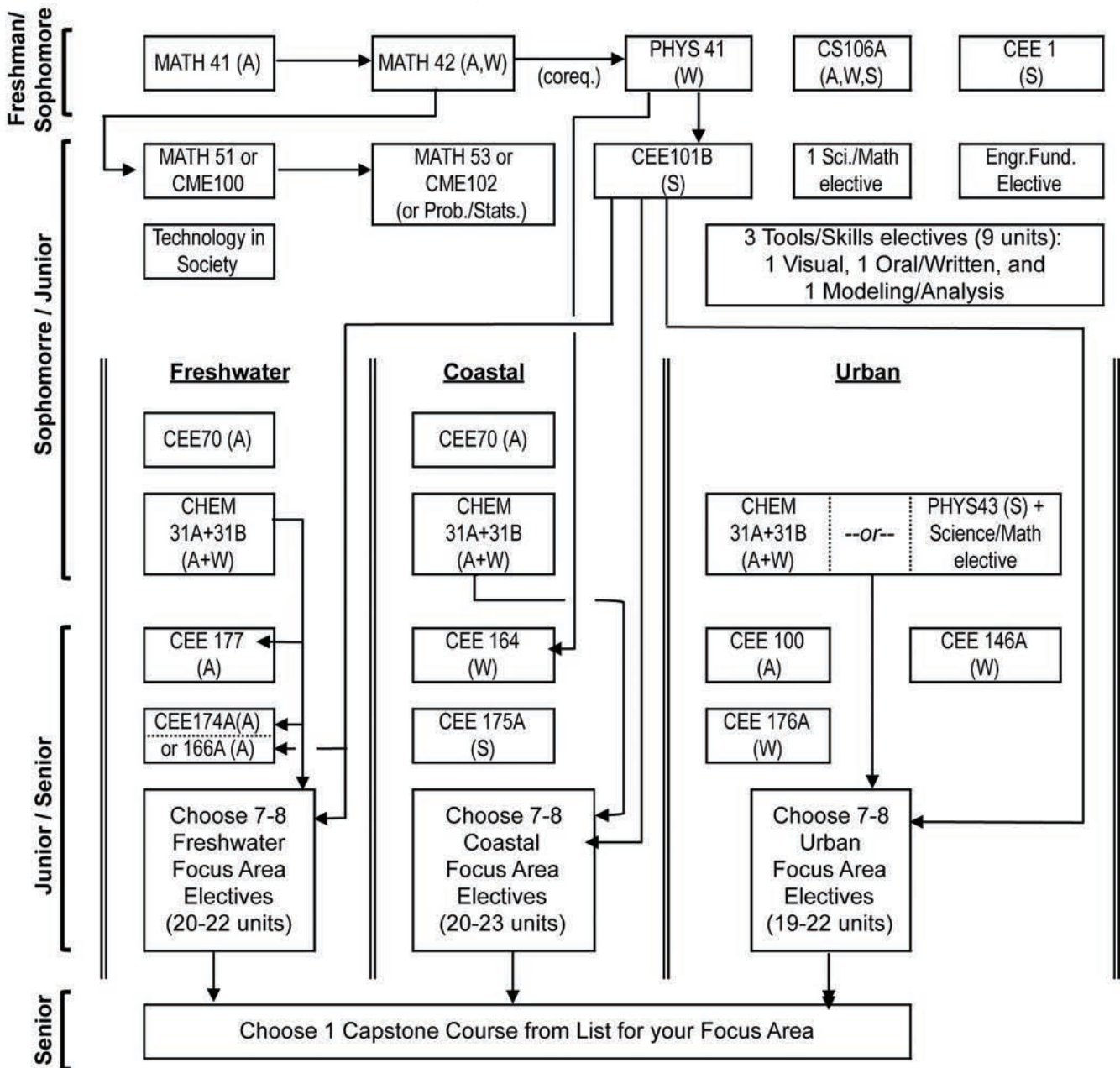

Environmental Systems Engineering -- Freshwater Focus

Late Start Program

	Fall				Winter				Spring			
	Math/				Math/				Math/			
	Class	Sci.	Engr	Other	Class	Sci.	Engr	Other	Class	Sci.	Engr	Other
<i>Freshman</i>	Unrstr Elctv #	-	-	4	Unrstr Elctv #	-	-	4	Unrstr Elctv #	-	-	4
	Unrstr Elctv #	-	-	4	Unrstr Elctv #	-	-	4	Unrstr Elctv #	-	-	4
	Unrstr Elctv #	-	-	3	Unrstr Elctv #	-	-	3	WAYS +	-	-	4
	PWR1	-	-	4	WAYS +	-	-	4	THINK	-	-	4
	<i>Subtotals</i>	0	0	15	<i>Subtotals</i>	0	0	15	<i>Subtotals</i>	0	0	16
Total	15			Total	15			Total	16			
<i>Sophomore</i>	Language	-	-	5	Language	-	-	5	Language	-	-	5
	MATH 19	3	-	-	MATH 20	3	-	-	MATH 21	4	-	-
	ENGR90/CEE70	-	3	-	WAYS +	-	-	5	WAYS +	-	-	3
	PWR2	-	-	4	Engr Fund #	-	3	-	WAYS +	-	-	4
	<i>Subtotals</i>	3	3	9	<i>Subtotals</i>	3	3	10	<i>Subtotals</i>	4	1	12
Total	15			Total	16			Total	17			
<i>Junior</i>	CHEM 31A ^{^^}	5	-	-	CHEM 31B ^{^^}	5	-	-	CEE 101B	-	4	-
	MATH 51 [^]	5	-	-	PHYSICS 41	4	-	-	CS 106A	-	5	-
	Tools/Skills	-	3	-	CEE 171 *	-	3	-	FreshW Elctv	-	3	-
	WAYS +	-	-	4	FreshW Elctv	-	3	-	Tools/Skills	-	3	-
	<i>Subtotals</i>	10	3	4	<i>Subtotals</i>	9	6	0	<i>Subtotals</i>	0	15	0
Total	17			Total	15			Total	15			
<i>Senior</i>	CEE166A or 174A	-	3	-	FreshW Elctv	-	3	-	FreshW Elctv	-	2	-
	CEE177	-	4	-	FreshW Elctv	-	3	-	Science/Math	3	-	-
	CEE141A *	-	3	-	FreshW Elctv	-	2	-	Prob/Stats. [^]	5	-	-
	FreshW Elctv	-	3	-	MS&E 197++	-	-	5	Tools/Skills	-	3	-
	<i>Subtotals</i>	0	13	0	<i>Subtotals</i>	0	8	5	<i>Subtotals</i>	8	5	0
Total	13			Total	13			Total	13			

Total Math & Science Units (min=36): 37
 Total ENGR Fundamentals+Tools/Skills+Focus Area Units (min=11+10+36=57): 57
 Total Other Units: 86
Total Units (min=180): 180

Notes:

--- Courses in this row can be rearranged, e.g., to accommodate PWR or a FreshW Elective any quarter.

Students should explore majors of interest to them using these unrestricted electives. Classes accessible to Fresh/Sophs that count towards Freshwater focus: CEE 70(A), CEE 166D(W), BIO 35N(W), CEE 29N(W), GES 43Q(W), CEE 50N(S).

[^] Can take CME 100 instead of MATH 51. Can take MATH 53 or CME 102 instead of Probability/Stats.

^{^^} If CHEM 31X or ENGR 31 is taken, replace CHEM31B with an SoE-approved science/math class.

+ May need 7 WAYS courses outside of major requirements: 2 in Aesthetic/Interpretive Inquiry, 2 in Social Inquiry, 1 in Ethical Reasoning, 1 in Engaging Diversity, and 1 in Creative Expression.

++ For a late start, MS&E 197 is recommended for TiS because it fulfills the WIM and WAYS-ER requirements. Other TiS classes with WIM + WAYS are COMM 120W (WAYS-SI) and MS&E193 (WAYS-SI).

* CEE 171 (=Freshwater elective) is recommended prereq for capstone class CEE 141A. May choose other capstone instead.

Environmental Systems Engineering -- Coastal Focus

Late Start Program

	Fall			Winter				Spring				
	Math/ Sci.	Engr	Other	Class	Math/ Sci.	Engr	Other	Class	Math/ Sci.	Engr	Other	
<i>Freshman</i>	Unrstr Elctv #	-	-	4	Unrstr Elctv #	-	-	4	Unrstr Elctv #	-	-	4
	Unrstr Elctv #	-	-	4	Unrstr Elctv #	-	-	4	Unrstr Elctv #	-	-	4
	Unrstr Elctv #	-	-	3	Unrstr Elctv #	-	-	3	WAYS +	-	-	4
	PWR1	-	-	4	WAYS +	-	-	4	THINK	-	-	4
	Subtotals	0	0	15	Subtotals	0	0	15	Subtotals	0	0	16
Total	15			Total	15			Total	16			
<i>Sophomore</i>	Language	-	-	5	Language	-	-	5	Language	-	-	5
	MATH 19	3	-	-	MATH 20	3	-	-	MATH 21	4	-	-
	ENGR90/CEE70	-	3	-	WAYS +	-	-	5	WAYS +	-	-	3
	PWR2	-	-	4	Engr Fund #	-	3	-	WAYS +	-	-	3
	Subtotals	3	3	9	Subtotals	3	3	10	Subtotals	4	1	11
Total	15			Total	16			Total	16			
<i>Junior</i>	CHEM 31A ^{^^}	5	-	-	CHEM 31B ^{^^}	5	-	-	CEE 175A	-	3	-
	MATH 51 [^]	5	-	-	PHYSICS 41	4	-	-	CEE 101B	-	4	-
		-	3	-	CEE 171 [*]	-	3	-		-	-	-
	Tools/Skills	-	3	-	Tools/Skills	-	3	-	Coastal Elctv	-	3	-
	Coastal Elctv	-	3	-		-	-	-	CS106A	-	5	-
Subtotals	10	6	0	Subtotals	9	6	0	Subtotals	0	15	0	
Total	16			Total	15			Total	15			
<i>Senior</i>	CEE 141A [*]	-	3	-	CEE 164	-	3	-		-	-	-
	Coastal Elctv	-	3	-	Coastal Elctv	-	3	-	Coastal Elctv	-	3	-
	Coastal Elctv	-	3	-	Science/Math	3	-	-	Coastal Elctv	-	2	-
	WAYS +	-	-	5	MS&E 197 ⁺⁺	-	-	5	Prob/Stats. [^]	5	-	-
	Subtotals	0	9	5	Subtotals	3	6	5	Subtotals	5	8	0
Total	14			Total	14			Total	13			

Total Math & Science Units (min=36): 37
 Total ENGR Fundamentals+Tools/Skills+Focus Area Units (min=11+10+36=57): 57
 Total Other Units: 86
Total Units (min=180): 180

Notes:

- Courses in this row can be rearranged, e.g., to accommodate PWR or a Coastal elective in any quarter.
- # Students should explore majors of interest to them using these unrestricted electives. Classes accessible to Fresh/Sophs which count towards Coastal focus: CEE 70(A), BIO 12N(A), EARTHSYS 56Q(W), BIO 3N(S), BIO 30(S), EESS 8(S), CEE 50N(S).
- [^] Can take CME 100 instead of MATH 51. Can take MATH 53 or CME 102 instead of Probability/Stats.
- ^{^^} If CHEM 31X or ENGR 31 is taken, replace CHEM31B with an SoE-approved science/math class.
- + May need 7 WAYS courses outside of major requirements: 2 in Aesthetic/Interpretive Inquiry, 2 in Social Inquiry, 1 in Ethical Reasoning, 1 in Engaging Diversity, and 1 in Creative Expression.
- ++ For a late start, MS&E 197 is recommended for TiS because it fulfills the WIM and WAYS-ER requirements. Other TiS classes with WIM + WAYS are COMM 120W (WAYS-SI) and MS&E193 (WAYS-SI).
- * CEE 171 (=Coastal Elctv) is recommended prereq for capstone CEE 141A. May choose other capstone instead.

Environmental Systems Engineering -- Urban Focus

Late Start Program

	<i>Fall</i>			<i>Winter</i>			<i>Spring</i>					
	Math/ Sci.	Engr	Other	Class	Math/ Sci.	Engr	Other	Class	Math/ Sci.	Engr	Other	
<i>Freshman</i>	Unrstr Elctv #	-	-	4	Unrstr Elctv #	-	-	4	Unrstr Elctv #	-	-	4
	Unrstr Elctv #	-	-	4	Unrstr Elctv #	-	-	4	Unrstr Elctv #	-	-	4
	Unrstr Elctv #	-	-	3	Unrstr Elctv #	-	-	3	WAYS +	-	-	4
	WAYS +	-	-	4	PWR1	-	-	4	THINK	-	-	4
	<i>Subtotals</i>	<i>0</i>	<i>0</i>	<i>15</i>	<i>Subtotals</i>	<i>0</i>	<i>0</i>	<i>15</i>	<i>Subtotals</i>	<i>0</i>	<i>0</i>	<i>16</i>
Total	15			Total	15			Total	16			
<i>Sophomore</i>	Language	-	-	5	Language	-	-	5	Language	-	-	5
	MATH 19	3	-	-	MATH 20	3	-	-	MATH 21	4	-	-
	WAYS +	-	-	4	WAYS +	-	-	4	WAYS +	-	-	3
	Engr Fund #	-	3	-	PWR2	-	-	4	WAYS +	-	-	3
	<i>Subtotals</i>	<i>3</i>	<i>3</i>	<i>9</i>	<i>Subtotals</i>	<i>3</i>	<i>0</i>	<i>13</i>	<i>Subtotals</i>	<i>4</i>	<i>1</i>	<i>11</i>
Total	15			Total	16			Total	16			
<i>Junior</i>	CEE 100 (WIM)	-	4	-	CEE 176A	-	3	-	CEE 101B	-	4	-
	MATH 51^	5	-	-	PHYSICS 41	4	-	-	PHYSICS 43^^	4	-	-
	Urban Elctv	-	3	-	Urban Elctv	-	3	-	CS 106A	-	5	-
	Tools/Skills	-	3	-	Urban Elctv	-	3	-	Urban Elctv	-	3	-
	<i>Subtotals</i>	<i>5</i>	<i>10</i>	<i>0</i>	<i>Subtotals</i>	<i>4</i>	<i>9</i>	<i>0</i>	<i>Subtotals</i>	<i>4</i>	<i>12</i>	<i>0</i>
Total	15			Total	13			Total	16			
<i>Senior</i>	Urban Elctv	-	3	-	CEE 146A	-	3	-	TiS ++	-	-	4
	Prob/Stats.^	5	-	-	Urban Elctv	-	4	-	Science/Math	4	-	-
	Capstone *	-	3	-	Urban Elctv	-	3	-	Tools/Skills	-	3	-
	Tools/Skills	-	3	-	Science/Math	4	-	-	WAYS + ++	-	-	4
	<i>Subtotals</i>	<i>5</i>	<i>9</i>	<i>0</i>	<i>Subtotals</i>	<i>4</i>	<i>10</i>	<i>0</i>	<i>Subtotals</i>	<i>4</i>	<i>3</i>	<i>8</i>
Total	14			Total	14			Total	15			

Total Math & Science Units (min=36): 36
 Total ENGR Fundamentals+Tools/Skills+Focus Area Units (min=11+10+36=57): 57
 Total Other Units: 87
Total Units (min=180): 180

Notes:

- Courses in this row can be rearranged, e.g., to accommodate PWR or an Urban elective in any quarter.
- # Students should explore majors of interest to them using these unrestricted electives. Classes accessible to Fresh/Sophs that count towards Urban focus: APPLPHYS 79N(A), ME 16N(A), AA 116Q(A), CEE 100(A), CEE 29N(W), ECON 17N(W), CEE 156(W), URBANST 113(W), CEE 50N(S).
- ^ Can take CME 100 instead of MATH 51. Can take MATH 53 or CME 102 instead of Probability/Stats.
- ^^ Can take CHEM 31A+B (or CHEM 31X or ENGR 31) instead of PHYSICS 43.
- + May need 7 WAYS courses outside of major requirements: 2 in Aesthetic/Interpretive Inquiry, 2 in Social Inquiry, 1 in Ethical Reasoning, 1 in Engaging Diversity, and 1 in Creative Expression.
- ++ For a late start, MS&E 197 is recommended for TiS because it fulfills the WIM and WAYS-ER requirements. Other TiS classes with WIM + WAYS are COMM 120W (WAYS-SI) and MS&E193 (WAYS-SI).
- * Make sure to schedule the appropriate prereqs (=Urban Elctvs) for your desired Capstone class.

Environmental Systems Engineering -- Freshwater Focus

Regular Start Program

	Fall				Winter				Spring				
	Math/ Sci.			Engr	Math/ Sci.			Engr	Math/ Sci.			Engr	Other
Class	Sci.	Engr	Other	Class	Sci.	Engr	Other	Class	Sci.	Engr	Other		
<i>Freshman</i>	MATH 41	5	-	-	MATH 42	5	-	-	CS106A	-	5	-	
	Unrstr Elctv #	-	-	3	PHYSICS 41	4	-	-	Unrstr Elctv #	-	-	3	
	Unrstr Elctv #	-	-	3	Unrstr Elctv #	-	-	3	WAYS +	-	-	4	
	THINK	-	-	4	WAYS +	-	-	4	PWR1	-	-	4	
	<i>Subtotals</i>	5	0	10	<i>Subtotals</i>	9	0	7	<i>Subtotals</i>	0	5	11	
	Total	15			Total	16			Total	16			
<i>Sophomore</i>	Language	-	-	5	Language	-	-	5	Language	-	-	5	
	CHEM 31A ^{^^}	5	-	-	CHEM 31B ^{^^}	5	-	-	MATH 51 [^]	5	-	-	
	ENGR90/CEE70	-	3	-	Engr Fund #	-	3	-	CEE 1	-	1	-	
	WAYS +	-	-	3	Unrstr Elctv #	-	-	3	PWR2	-	-	4	
	<i>Subtotals</i>	5	3	8	<i>Subtotals</i>	5	3	8	<i>Subtotals</i>	5	1	9	
	Total	16			Total	16			Total	15			
<i>Junior</i>	CEE177	-	4	-	FreshW Elctv	-	2	-	CEE 101B	-	4	-	
	Science/Math	3	-	-	FreshW Elctv	-	3	-	Prob/Stats. [^]	5	-	-	
	Tools/Skills	-	3	-	WAYS +	-	-	5	WAYS +	-	-	4	
	WAYS +	-	-	5	TiS ++	-	-	5	Tools/Skills	-	3	-	
	<i>Subtotals</i>	3	7	5	<i>Subtotals</i>	0	5	10	<i>Subtotals</i>	5	7	4	
	Total	15			Total	15			Total	16			
<i>Senior</i>	CEE166A or 174A	-	3	-	FreshW Elctv	-	3	-	FreshW Elctv	-	2	-	
	FreshW Elctv	-	3	-	FreshW Elctv	-	3	-	Tools/Skills	-	3	-	
	Capstone*	-	3	-	FreshW Elctv	-	3	-	WAYS +	-	-	4	
	Unrstr Elctv	-	-	5	Unrstr Elctv	-	-	5	FreshW Elctv	-	3	-	
	<i>Subtotals</i>	0	9	5	<i>Subtotals</i>	0	9	5	<i>Subtotals</i>	0	8	4	
	Total	14			Total	14			Total	12			

Total Math & Science Units (min=36): 37

Total ENGR Fundamentals+Tools/Skills+Focus Area Units (min=11+10+36=57): 57

Total Other Units: 86

Total Units (min=180): 180

Notes:

- Courses in this row can be rearranged, e.g., to accommodate PWR or a FreshW Elective any quarter.
- # Students should explore majors of interest to them using these unrestricted electives. Classes accessible to Fresh/Sophs that count towards Freshwater focus: CEE 70(A), CEE 166D(W), BIO 35N(W), CEE 29N(W), GES 43Q(W), CEE 50N(S).
- [^] Can take CME 100 instead of MATH 51. Can take MATH 53 or CME 102 instead of Probability/Stats.
- ^{^^} If CHEM 31X or ENGR 31 is taken, replace CHEM31B with an SoE-approved science/math class.
- + May need 7 WAYS courses outside of major requirements: 2 in Aesthetic/Interpretive Inquiry, 2 in Social Inquiry, 1 in Ethical Reasoning, 1 in Engaging Diversity, and 1 in Creative Expression.
- ++ Some TiS classes also fulfill a WAYS or WIM reqmt: For WAYS-ER, choose ENGR 131 (A,S) or MS&E 197 (W; also WIM); for WAYS-SI, choose COMM 120W (S; also WIM), COMM 169 (W), MS&E181 (S), MS&E193 (A; also WIM), or POLISCI 114S (W).
- * Make sure to schedule the appropriate prereqs (FreshW electives) for your desired Capstone class.

Environmental Systems Engineering -- Coastal Focus

Regular Start Program

	Fall				Winter				Spring			
	Math/				Math/				Math/			
	Class	Sci.	Engr	Other	Class	Sci.	Engr	Other	Class	Sci.	Engr	Other
<i>Freshman</i>	MATH 41	5	-	-	MATH 42	5	-	-	CS106A	-	5	-
	<i>Unrstr Elctv #</i>	-	-	3	PHYSICS 41	4	-	-	<i>Unrstr Elctv #</i>	-	-	3
	WAYS +	-	-	3	<i>Unrstr Elctv #</i>	-	-	3	WAYS +	-	-	4
	THINK	-	-	4	WAYS +	-	-	4	PWR1	-	-	4
	<i>Subtotals</i>	5	0	10	<i>Subtotals</i>	9	0	7	<i>Subtotals</i>	0	5	11
Total	15			Total	16			Total	16			
<i>Sophomore</i>	Language	-	-	5	Language	-	-	5	Language	-	-	5
	CHEM 31A ^{^^}	5	-	-	CHEM 31B ^{^^}	5	-	-	MATH 51 [^]	5	-	-
	ENGR90/CEE70	-	3	-	Engr Fund #	-	3	-	CEE 1	-	1	-
	WAYS +	-	-	3	<i>Unrstr Elctv #</i>	-	-	4	PWR2	-	-	4
	<i>Subtotals</i>	5	3	8	<i>Subtotals</i>	5	3	9	<i>Subtotals</i>	5	1	9
Total	16			Total	17			Total	15			
<i>Junior</i>	<i>Coastal Elctv</i>	-	3	-	CEE164	-	3	-	CEE 101B	-	4	-
	<i>Coastal Elctv</i>	-	3	-	<i>Coastal Elctv</i>	-	3	-	CEE 175A	-	3	-
	Science/Math	3	-	-	Prob/Stats. [^]	5	-	-	<i>Coastal Elctv</i>	-	3	-
	<i>Unrstr Elctv</i>	-	-	5	TiS ++	-	-	5	Tools/Skills	-	3	-
	<i>Subtotals</i>	3	6	5	<i>Subtotals</i>	5	6	5	<i>Subtotals</i>	0	13	0
Total	14			Total	16			Total	13			
<i>Senior</i>	<i>Coastal Elctv</i>	-	3	-	<i>Coastal Elctv</i>	-	3	-	<i>Coastal Elctv</i>	-	2	-
	Tools/Skills	-	3	-	Tools/Skills	-	3	-	<i>Coastal Elctv</i>	-	3	-
	Capstone*	-	3	-	WAYS +	-	-	4	WAYS + ++	-	-	4
	WAYS +	-	-	5	<i>Unrstr Elctv</i>	-	-	5	<i>Unrstr Elctv</i>	-	-	4
	<i>Subtotals</i>	0	9	5	<i>Subtotals</i>	0	6	9	<i>Subtotals</i>	0	5	8
Total	14			Total	15			Total	13			

Total Math & Science Units (min=36): 37

Total ENGR Fundamentals+Tools/Skills+Focus Area Units (min=11+10+36=57): 57

Total Other Units: 86

Total Units (min=180): 180

Notes:

--- Courses in this row can be rearranged, e.g., to accommodate PWR or a Coastal elective in any quarter.

Students should explore majors of interest to them using these unrestricted electives. Classes accessible to Fresh/Sophs which count towards Coastal focus: CEE 70(A), BIO 12N(A), EARTHSYS 56Q(W), BIO 3N(S), BIO 30(S), EESS 8(S), CEE 50N(S).

[^] Can take CME 100 instead of MATH 51. Can take MATH 53 or CME 102 instead of Probability/Stats.

^{^^} If CHEM 31X or ENGR 31 is taken, replace CHEM31B with an SoE-approved science/math class.

+ May need 7 WAYS courses outside of major requirements: 2 in Aesthetic/Interpretive Inquiry, 2 in Social Inquiry, 1 in Ethical Reasoning, 1 in Engaging Diversity, and 1 in Creative Expression.

++ Some TiS classes also fulfill a WAYS or WIM reqmt: For WAYS-ER, choose ENGR 131 (A,S) or MS&E 197 (W; also WIM); for WAYS-SI, choose COMM 120W (S; also WIM), COMM 169 (W), MS&E181 (S), MS&E193 (A; also WIM), or POLISCI 114S (W).

* Make sure to schedule the appropriate prereqs (Coastal electives) for your desired Capstone class.

Environmental Systems Engineering -- Urban Focus

Regular Start Program

	Fall				Winter				Spring			
	Math/ Sci.	Engr	Other		Math/ Sci.	Engr	Other		Math/ Sci.	Engr	Other	
<i>Freshman</i>	MATH 41	5	-	-	MATH 42	5	-	-	CS106A	-	5	-
	<i>Unrstr Elctv #</i>	-	-	3	PHYSICS 41	4	-	-	<i>Unrstr Elctv #</i>	-	-	3
	WAYS +	-	-	3	<i>Unrstr Elctv #</i>	-	-	3	WAYS +	-	-	4
	THINK	-	-	4	WAYS +	-	-	4	PWR1	-	-	4
	<i>Subtotals</i>	5	0	10	<i>Subtotals</i>	9	0	7	<i>Subtotals</i>	0	5	11
Total	15			Total	16			Total	16			
<i>Sophomore</i>	Language	-	-	5	Language	-	-	5	Language	-	-	5
	MATH 51 [^]	5	-	-	WAYS +	-	-	5	PHYSICS 43 ^{^^}	4	-	-
	Engr Fund #	-	3	-	<u>Urban Elctv</u>	-	3	-	CEE 1	-	1	-
	WAYS +	-	-	3	<i>Unrstr Elctv #</i>	-	-	3	PWR2	-	-	4
	<i>Subtotals</i>	5	3	8	<i>Subtotals</i>	0	3	13	<i>Subtotals</i>	4	1	9
Total	16			Total	16			Total	14			
<i>Junior</i>	CEE 100 (WIM)	-	4	-	CEE 176A	-	3	-	CEE 101B	-	4	-
	Science/Math	4	-	-	Prob/Stats. [^]	5	-	-	Science/Math	4	-	-
	<u>Urban Elctv</u>	-	3	-	<u>Urban Elctv</u>	-	3	-	TiS ++	-	-	5
	<u>Urban Elctv</u>	-	3	-	WAYS +	-	-	4	Tools/Skills	-	3	-
	<i>Subtotals</i>	4	10	0	<i>Subtotals</i>	5	6	4	<i>Subtotals</i>	4	7	5
Total	14			Total	15			Total	16			
<i>Senior</i>	<u>Urban Elctv</u>	-	3	-	CEE 146A	-	3	-	Tools/Skills	-	3	-
	Capstone *	-	3	-	<u>Urban Elctv</u>	-	4	-	WAYS + ++	-	-	5
	Tools/Skills	-	3	-	<u>Urban Elctv</u>	-	3	-	<i>Unrstr Elctv</i>	-	-	5
	<i>Unrstr Elctv</i>	-	-	5	<i>Unrstr Elctv</i>	-	-	5	<i>Unrstr Elctv</i>	-	-	5
	<i>Subtotals</i>	0	9	5	<i>Subtotals</i>	0	10	5	<i>Subtotals</i>	0	3	10
Total	14			Total	15			Total	13			

Total Math & Science Units (min=36): 36

Total ENGR Fundamentals+Tools/Skills+Focus Area Units (min=11+10+36=57): 57

Total Other Units: 87

Total Units (min=180): 180

Notes:

- Courses in this row can be rearranged, e.g., to accommodate PWR or an Urban elective in any quarter.
- # Students should explore majors of interest to them using these unrestricted electives. Classes accessible to Fresh/Sophs that count towards Urban focus: APPLPHYS 79N(A), ME 16N(A), AA 116Q(A), CEE 100(A), CEE 29N(W), ECON 17N(W), CEE 156(W), UrbanSt113(W), CEE50N(S).
- [^] Can take CME 100 instead of MATH 51. Can take MATH 53 or CME 102 instead of Probability/Stats.
- ^{^^} Can take CHEM 31A+B (or CHEM 31X or ENGR 31) instead of PHYSICS 43.
- + May need 7 WAYS courses outside of major requirements: 2 in Aesthetic/Interpretive Inquiry, 2 in Social Inquiry, 1 in Ethical Reasoning, 1 in Engaging Diversity, and 1 in Creative Expression.
- ++ Some TiS classes also fulfill a WAYS reqmt: For WAYS-ER, take ENGR 131(A,S) or MS&E 197(W); for WAYS-SI, choose COMM 120W(S), COMM 169(W), MS&E181(S), MS&E193(A), or POLISCI 114S(W).
- * Make sure to schedule the appropriate prereqs (= Urban electives) for your desired Capstone class.

Environmental Systems Engineering -- Freshwater focus

Autumn Qtr Junior Year Abroad **

	Fall				Winter				Spring			
	Class	Math/ Sci.	Engr	Other	Class	Math/ Sci.	Engr	Other	Class	Math/ Sci.	Engr	Other
<i>Freshman</i>	MATH 41	5	-	-	MATH 42	5	-	-	CS106A	-	5	-
	<i>Unrstr Elctv #</i>	-	-	3	PHYSICS 41	4	-	-	<i>Unrstr Elctv #</i>	-	-	3
	<i>Unrstr Elctv #</i>	-	-	3	<i>Unrstr Elctv #</i>	-	-	3	WAYS +	-	-	4
	THINK	-	-	4	WAYS +	-	-	4	PWR1	-	-	4
	<i>Subtotals</i>	5	0	10	<i>Subtotals</i>	9	0	7	<i>Subtotals</i>	0	5	11
Total	15			Total	16			Total	16			
<i>Sophomore</i>	Language	-	-	5	Language	-	-	5	Language	-	-	5
	CHEM 31A^^	5	-	-	CHEM 31B^^	5	-	-	Math/Sci	3	-	-
	ENGR90/CEE70	-	3	-	Engr Fund **	-	3	-	<i>Unrstr Elctv</i>	-	-	3
	WAYS +	-	-	3	<i>Unrstr Elctv #</i>	-	-	3	PWR2	-	-	4
	<i>Subtotals</i>	5	3	8	<i>Subtotals</i>	5	3	8	<i>Subtotals</i>	3	1	12
Total	16			Total	16			Total	16			
<i>Junior</i>	WAYS +	-	-	5	<u>FreshW Elctv</u>	-	3	-	CEE 101B	-	4	-
	WAYS +	-	-	4	<u>FreshW Elctv</u>	-	3	-	Prob/Stats.^	5	-	-
	<i>Unrstr Elctv</i>	-	-	5	MATH 51^	5	-	-	WAYS +	-	-	5
	--- Autumn Quarter Abroad --- **	-	-	-	TiS ++	-	-	5	Tools/Skills	-	3	-
	<i>Subtotals</i>	0	0	14	<i>Subtotals</i>	5	6	5	<i>Subtotals</i>	5	7	5
Total	14			Total	16			Total	17			
<i>Senior</i>	CEE166A or 174A	-	3	-	<u>FreshW Elctv</u>	-	3	-	<u>FreshW Elctv</u>	-	2	-
	CEE177	-	4	-	<u>FreshW Elctv</u>	-	3	-	<u>FreshW Elctv</u>	-	3	-
	<u>FreshW Elctv</u>	-	3	-	<u>FreshW Elctv</u>	-	3	-	Tools/Skills	-	3	-
	Capstone*	-	3	-	Tools/Skills	-	3	-	WAYS + ++	-	-	5
	<i>Subtotals</i>	0	13	0	<i>Subtotals</i>	0	12	0	<i>Subtotals</i>	0	8	5
Total	13			Total	12			Total	13			

Total Math & Science Units (min=36): 37

Total Eng.Fund.+Tools/Sk.+Focus Area Units (min=11+10+36=57): 58

Total Other Units: 85

Total Units (min=180): 180

Notes:

--- Courses in this row can be rearranged, e.g., to accommodate PWR or a FreshW Elective any quarter.

Students should explore majors of interest to them using these unrestricted electives. Classes accessible to Fresh/Sophs that count towards Freshwater focus: CEE 70(A), CEE 166D(W), BIO 35N(W), CEE 29N(W), GES 43Q(W), CEE 50N(S).

^ Can take CME 100 instead of MATH 51. Can take MATH 53 or CME 102 instead of Probability/Stats.

^^ If CHEM 31X or ENGR 31 is taken, replace CHEM 31B with an SoE-approved science/math class.

+ May need 7 WAYS courses outside of major requirements: 2 in Aesthetic/Interpretive Inquiry, 2 in Social Inquiry, 1 in Ethical Reasoning, 1 in Engaging Diversity, and 1 in Creative Expression.

++ Some TiS classes also fulfill a WAYS or WIM reqmt: For WAYS-ER, choose ENGR 131 (A,S) or MS&E 197 (W; also WIM); for WAYS-SI, choose COMM 120W (S; also WIM), COMM 169 (W), MS&E181 (S), MS&E193 (A; also WIM), or POLISCI 114S (W).

* Make sure you have scheduled the appropriate prereqs (=FreshW Elctvs) for your desired Capstone class.

** Aut Qtr abroad is easy for this focus area! See footnote to Focus Area page for which Overseas classes can count as electives. And some Overseas programs offer ENGR 40 or 50 (which could count as the 3rd ENGR Fund).

Environmental Systems Engineering -- Freshwater focus

Winter Qtr Junior Year Abroad

	<i>Fall</i>				<i>Winter</i>				<i>Spring</i>			
	Math/ Sci.	Engr	Other		Math/ Sci.	Engr	Other		Math/ Sci.	Engr	Other	
<i>Freshman</i>	MATH 41	5	-	-	MATH 42	5	-	-	CS106A	-	5	-
	<i>Unrstr Elctv #</i>	-	-	3	PHYSICS 41	4	-	-	<i>Unrstr Elctv #</i>	-	-	3
	<i>Unrstr Elctv #</i>	-	-	3	<i>Unrstr Elctv #</i>	-	-	3	WAYS +	-	-	4
	THINK	-	-	4	WAYS +	-	-	4	PWR1	-	-	4
	<i>Subtotals</i>	5	0	10	<i>Subtotals</i>	9	0	7	<i>Subtotals</i>	0	5	11
Total	15			Total	16			Total	16			
<i>Sophomore</i>	Language	-	-	5	Language	-	-	5	Language	-	-	5
	CHEM 31A ^{^^}	5	-	-	CHEM 31B ^{^^}	5	-	-	Math/Sci	3	-	-
	ENGR90/CEE70	-	3	-	Engr Fund **	-	3	-	<i>Unrstr Elctv</i>	-	-	3
	WAYS +	-	-	3	<i>Unrstr Elctv</i> **	-	-	3	PWR2	-	-	4
	<i>Subtotals</i>	5	3	8	<i>Subtotals</i>	5	3	8	<i>Subtotals</i>	3	1	12
Total	16			Total	16			Total	16			
<i>Junior</i>	<i>FreshW Elctv</i>	-	3	-	WAYS +	-	-	5	CEE 101B	-	4	-
	Tools/Skills	-	3	-	WAYS +	-	-	4	Prob/Stats. [^]	5	-	-
	MATH 51 [^]	5	-	-	<i>Unrstr Elctv</i>	-	-	5	WAYS +	-	-	5
	TiS ++	-	-	5	--- Winter Quarter Abroad --- **				Tools/Skills	-	3	-
	<i>Subtotals</i>	5	6	5	<i>Subtotals</i>	0	0	14	<i>Subtotals</i>	5	7	5
Total	16			Total	14			Total	17			
<i>Senior</i>	CEE166A or 174A	-	3	-	<i>FreshW Elctv</i>	-	3	-	<i>FreshW Elctv</i>	-	2	-
	CEE177	-	4	-	<i>FreshW Elctv</i>	-	3	-	<i>FreshW Elctv</i>	-	3	-
	<i>FreshW Elctv</i>	-	3	-	<i>FreshW Elctv</i>	-	3	-	<i>FreshW Elctv</i>	-	3	-
	Capstone*	-	3	-	<i>FreshW Elctv</i>	-	3	-	<i>FreshW Elctv</i>	-	3	-
	<i>Subtotals</i>	0	13	0	<i>Subtotals</i>	0	12	0	<i>Subtotals</i>	0	8	5
Total	13			Total	12			Total	13			

Total Math & Science Units (min=36): 37

Total Eng.Fund.+Tools/Sk.+Focus Area Units (min=11+10+36=57): 58

Total Other Units: 85

Total Units (min=180): 180

Notes:

- # Courses in this row can be rearranged, e.g., to accommodate PWR or a FreshW Elective any quarter.
- # Students should explore majors of interest to them using these unrestricted electives. Classes accessible to Fresh/Sophs that count towards Freshwater focus: CEE 70(A), CEE 166D(W), BIO 35N(W), CEE 29N(W), GES 43Q(W), CEE 50N(S)
- ^ Can take CME 100 instead of MATH 51. Can take MATH 53 or CME 102 instead of Probability/Stats.
- ^^ If CHEM 31X or ENGR 31 is taken, replace CHEM31B with an SoE-approved science/math class.
- + May need 7 WAYS courses outside of major requirements: 2 in Aesthetic/Interpretive Inquiry, 2 in Social Inquiry, 1 in Ethical Reasoning, 1 in Engaging Diversity, and 1 in Creative Expression.
- ++ Some TiS classes also fulfill a WAYS or WIM reqmt: For WAY-ER, choose ENGR 131(A,S) or MS&E 197(W; also WIM); for WAY-SI, choose COMM 120W(S; also WIM), COMM 169(W), MS&E 181(S), MS&E 193 (A; also WIM), or POLISCI 114S(W).
- * Make sure you have scheduled the appropriate prereqs (=FreshW Elctvs) for your desired Capstone class.
- ** One drawback to Win Qtr abroad: Many Freshwater electives are Win qtr. Might want to take an elective (maybe CEE166D?) Win qtr of Soph Year. See footnote to Focus Area page for which Overseas classes can count as electives. And some Overseas programs offer ENGR 40 or 50 (which could count as the 3rd ENGR Fund).

Environmental Systems Engineering -- Freshwater focus

Spring Qtr Junior Year Abroad

	Fall				Winter				Spring			
	Math/				Math/				Math/			
	Class	Sci.	Engr	Other	Class	Sci.	Engr	Other	Class	Sci.	Engr	Other
<i>Freshman</i>	MATH 41	5	-	-	MATH 42	5	-	-	CS106A	-	5	-
	<i>Unrstr Elctv #</i>	-	-	3	PHYSICS 41	4	-	-	<i>Unrstr Elctv #</i>	-	-	3
	<i>Unrstr Elctv #</i>	-	-	3	<i>Unrstr Elctv #</i>	-	-	3	WAYS +	-	-	4
	THINK	-	-	4	WAYS +	-	-	4	PWR1	-	-	4
	<i>Subtotals</i>	5	0	10	<i>Subtotals</i>	9	0	7	<i>Subtotals</i>	0	5	11
Total	15			Total	16			Total	16			
<i>Sophomore</i>	Language	-	-	5	Language	-	-	5	Language	-	-	5
	CHEM 31A ^{^^}	5	-	-	CHEM 31B ^{^^}	5	-	-	CEE101B **	-	4	-
	ENGR90/CEE70	-	3	-	Engr Fund **	-	3	-	<i>Unrstr Elctv</i>	-	-	3
	WAYS +	-	-	3	<i>Unrstr Elctv #</i>	-	-	3	PWR2	-	-	4
	<i>Subtotals</i>	5	3	8	<i>Subtotals</i>	5	3	8	<i>Subtotals</i>	0	5	12
Total	16			Total	16			Total	17			
<i>Junior</i>	<i>FreshW Elctv</i>	-	3	-	<i>FreshW Elctv</i>	-	3	-	WAYS +	-	-	5
	Tools/Skills	-	3	-	Prob/Stats. [^]	5	-	-	WAYS +	-	-	4
	MATH 51 [^]	5	-	-	WAYS +	-	-	5	<i>Unrstr Elctv</i>	-	-	5
	TiS ++	-	-	5	Tools/Skills	-	3	-	--- Spring Quarter Abroad --- **			
	<i>Subtotals</i>	5	6	5	<i>Subtotals</i>	5	6	5	<i>Subtotals</i>	0	0	14
Total	16			Total	16			Total	14			
<i>Senior</i>	CEE166A or 174A	-	3	-	---	---	---	---	---	---	---	---
	CEE177	-	4	-	<i>FreshW Elctv</i>	-	3	-	<i>FreshW Elctv</i>	-	2	-
	<i>FreshW Elctv</i>	-	3	-	<i>FreshW Elctv</i>	-	3	-	<i>FreshW Elctv</i>	-	3	-
	Capstone*	-	3	-	<i>FreshW Elctv</i>	-	3	-	Tools/Skills	-	3	-
	<i>Subtotals</i>	0	13	0	<i>Subtotals</i>	3	9	0	<i>Subtotals</i>	0	8	5
Total	13			Total	12			Total	13			

Total Math & Science Units (min=36): 37

Total Eng.Fund.+Tools/Sk.+Focus Area Units (min=11+10+36=57): 58

Total Other Units: 85

Total Units (min=180): 180

Notes:

----- Courses in this row can be rearranged, e.g., to accommodate PWR or a FreshW Elective any quarter.

Students should explore majors of interest to them using these unrestricted electives. Classes accessible to Fresh/Sophs that count towards Freshwater focus: CEE 70(A), CEE 166D(W), BIO 35N(W), CEE 29N(W), GES 43Q(W), CEE 50N(S).

^ Can take CME 100 instead of MATH 51. Can take MATH 53 or CME 102 instead of Probability/Stats.

^^ If CHEM 31X or ENGR 31 is taken, replace CHEM31B with an SoE-approved science/math class.

+ May need 7 WAYS courses outside of major requirements: 2 in Aesthetic/Interpretive Inquiry, 2 in Social Inquiry, 1 in Ethical Reasoning, 1 in Engaging Diversity, and 1 in Creative Expression.

++ Some TiS classes also fulfill a WAYS or WIM reqmt: For WAY-ER, choose Engr131(A,S) or MS&E197(W; also WIM); for WAY-SI, choose Comm120W(S; also WIM), Comm169(W), MS&E181(S), MS&E193(A; also WIM), or PoliSci114S(W).

* Make sure you have scheduled the appropriate prereqs (=FreshW Elctvs) for your desired Capstone class.

** To do Spring Qtr Abroad, MUST take CEE101B in Spring of Soph year (or petition to take ME 70 in Win of Jr year as a substitute). See footnote to Focus Area page for which Overseas classes can count as electives. And some Overseas programs offer ENGR 40 or 50 (which could count as the 3rd ENGR Fund).

Environmental Systems Engineering -- Coastal focus

Autumn Qtr Junior Year Abroad **

	Fall			Winter			Spring					
	Math/ Sci.	Engr	Other	Class	Math/ Sci.	Engr	Other	Class	Math/ Sci.	Engr	Other	
<i>Freshman</i>	MATH 41	5	-	-	MATH 42	5	-	-	CS106A	-	5	-
	<i>Unrstr Elctv #</i>	-	-	3	PHYSICS 41	4	-	-	<i>Unrstr Elctv #</i>	-	-	3
	<i>Unrstr Elctv #</i>	-	-	3	<i>Unrstr Elctv #</i>	-	-	3	WAYS +	-	-	4
	THINK	-	-	4	WAYS +	-	-	4	PWR1	-	-	4
	<i>Subtotals</i>	5	0	10	<i>Subtotals</i>	9	0	7	<i>Subtotals</i>	0	5	11
Total	15			Total	16			Total	16			
<i>Sophomore</i>	Language	-	-	5	Language	-	-	5	Language	-	-	5
	CHEM 31A ^{^^}	5	-	-	CHEM 31B ^{^^}	5	-	-	Math/Sci	3	-	-
	ENGR90/CEE70	-	3	-	Engr Fund #	-	3	-	<i>Unrstr Elctv</i>	-	-	3
	WAYS +	-	-	3	<i>Unrstr Elctv #</i>	-	-	4	PWR2	-	-	4
	<i>Subtotals</i>	5	3	8	<i>Subtotals</i>	5	3	9	<i>Subtotals</i>	3	1	12
Total	16			Total	17			Total	16			
<i>Junior</i>	WAYS +	-	-	5	CEE164	-	3	-	CEE 101B	-	4	-
	WAYS +	-	-	4	MATH 51 [^]	5	-	-	CEE 175A	-	3	-
	<i>Unrstr Elctv</i>	-	-	5	<u>Coastal Elctv</u>	-	3	-	<u>Coastal Elctv</u>	-	3	-
	<i>--- Autumn Quarter Abroad --- **</i>	-	-	-	Tools/Skills	-	3	-	WAYS +	-	-	5
	<i>Subtotals</i>	0	0	14	<i>Subtotals</i>	5	9	0	<i>Subtotals</i>	0	10	5
Total	14			Total	14			Total	15			
<i>Senior</i>	<u>Coastal Elctv</u>	-	3	-	<u>Coastal Elctv</u>	-	3	-	<u>Coastal Elctv</u>	-	2	-
	<u>Coastal Elctv</u>	-	3	-	Prob/Stats [^]	5	-	-	<u>Coastal Elctv</u>	-	3	-
	Capstone*	-	3	-	Tools/Skills	-	3	-	<u>Coastal Elctv</u>	-	3	-
	TiS ++	-	-	5	Tools/Skills	-	3	-	WAYS + ++	-	-	5
	<i>Subtotals</i>	0	9	5	<i>Subtotals</i>	5	9	0	<i>Subtotals</i>	0	8	5
Total	14			Total	14			Total	13			

Total Math & Science Units (min=36): 37

Total Eng.Fund.+Tools/Sk.+Focus Area Units (min=11+10+36=57): 57

Total Other Units: 86

Total Units (min=180): 180

Notes:

- Courses in this row can be rearranged, e.g., to accommodate PWR or a Coastal elective in any quarter.
- # Students should explore majors of interest to them using these unrestricted electives. Classes accessible to Fresh/Sophs which count towards Coastal focus: CEE 70(A), BIO 12N(A), EARTHSYS 56Q(W), BIO 3N(S), BIO 30(S), EESS 8(S), CEE 50N(S).
- ^ Can take CME 100 instead of MATH 51. Can take MATH 53 or CME 102 instead of Probability/Stats.
- ^^ If CHEM 31X or ENGR 31 is taken, replace CHEM31B with an SoE-approved science/math class.
- + May need 7 WAYS courses outside of major requirements: 2 in Aesthetic/Interpretive Inquiry, 2 in Social Inquiry, 1 in Ethical Reasoning, 1 in Engaging Diversity, and 1 in Creative Expression.
- ++ Some TiS classes also fulfill a WAYS or WIM reqmt: For WAYS-ER, choose ENGR 131 (A,S) or MS&E 197 (W; also WIM); for WAYS-SI, choose COMM 120W (S; also WIM), COMM 169 (W), MS&E 181 (S), MS&E 193 (A; also WIM), or POLISCI 114S (W).
- * Make sure to schedule the appropriate prereqs (Coastal electives) for your desired Capstone class.
- ** Aut Qtr abroad is easy for this focus area! See footnote to Focus Area page for which Overseas classes can count as electives. And some Overseas programs offer ENGR 40 or 50 (which could count as the 3rd ENGR Fund).

Environmental Systems Engineering -- Coastal focus

Winter Qtr Junior Year Abroad **

	Fall			Winter			Spring					
	Math/ Sci.	Engr	Other	Class	Math/ Sci.	Engr	Other	Class	Math/ Sci.	Engr	Other	
<i>Freshman</i>	MATH 41	5	-	-	MATH 42	5	-	-	CS106A	-	5	-
	<i>Unrstr Elctv #</i>	-	-	3	PHYSICS 41	4	-	-	<i>Unrstr Elctv #</i>	-	-	3
	<i>Unrstr Elctv #</i>	-	-	3	<i>Unrstr Elctv #</i>	-	-	3	WAYS +	-	-	4
	THINK	-	-	4	WAYS +	-	-	4	PWR1	-	-	4
	<i>Subtotals</i>	5	0	10	<i>Subtotals</i>	9	0	7	<i>Subtotals</i>	0	5	11
Total	15			Total	16			Total	16			
<i>Sophomore</i>	Language	-	-	5	Language	-	-	5	Language	-	-	5
	CHEM 31A ^{^^}	5	-	-	CHEM 31B ^{^^}	5	-	-	Math/Sci	3	-	-
	ENGR90/CEE70	-	3	-	Engr Fund #	-	3	-	<i>Unrstr Elctv</i>	-	-	3
	WAYS +	-	-	3	<i>Unrstr Elctv #</i>	-	-	3	PWR2	-	-	4
	<i>Subtotals</i>	5	3	8	<i>Subtotals</i>	5	3	8	<i>Subtotals</i>	3	1	12
Total	16			Total	16			Total	16			
<i>Junior</i>	MATH 51 [^]	5	-	-	WAYS +	-	-	5	CEE 101B	-	4	-
	<u>Coastal Elctv</u>	-	3	-	WAYS +	-	-	4	CEE 175A	-	3	-
	Tools/Skills	-	3	-	<i>Unrstr Elctv</i>	-	-	5	<u>Coastal Elctv</u>	-	3	-
	WAYS +	-	-	5	--- Winter Quarter Abroad --- **				Prob/Stats. [^]	5	-	-
	<i>Subtotals</i>	5	6	5	<i>Subtotals</i>	0	0	14	<i>Subtotals</i>	5	10	0
Total	16			Total	14			Total	15			
<i>Senior</i>	<u>Coastal Elctv</u>	-	3	-	CEE164	-	3	-	<u>Coastal Elctv</u>	-	3	-
	Capstone*	-	3	-	<u>Coastal Elctv</u>	-	3	-	<u>Coastal Elctv</u>	-	3	-
	Tools/Skills	-	3	-	WAYS + ⁺⁺	-	-	5	Tools/Skills	-	3	-
	TiS ⁺⁺	-	-	5	<i>Subtotals</i>	0	9	5	<i>Subtotals</i>	0	12	0
	<i>Subtotals</i>	0	9	5	Total	14			Total	12		

Total Math & Science Units (min=36): 37

Total Eng.Fund.+Tools/Sk.+Focus Area Units (min=11+10+36=57): 58

Total Other Units: 85

Total Units (min=180): 180

Notes:

 ----- Courses in this row can be rearranged, e.g., to accommodate PWR or a Coastal elective in any quarter.

Students should explore majors of interest to them using these unrestricted electives. Classes accessible to Fresh/Sophs which count towards Coastal focus: CEE 70(A), BIO 12N(A), EARTHSYS 56Q(W), BIO 3N(S), BIO 30(S), EESS 8(S), CEE 50N(S).

[^] Can take CME 100 instead of MATH 51. Can take MATH 53 or CME 102 instead of Probability/Stats.

^{^^} If CHEM 31X or ENGR 31 is taken, replace CHEM31B with an SoE-approved science/math class.

+ May need 7 WAYS courses outside of major requirements: 2 in Aesthetic/Interpretive Inquiry, 2 in Social Inquiry, 1 in Ethical Reasoning, 1 in Engaging Diversity, and 1 in Creative Expression.

⁺⁺ Some TiS classes also fulfill a WAYS or WIM reqmt: For WAYS-ER, choose ENGR 131 (A,S) or MS&E 197 (W; also WIM); for WAYS-SI, choose COMM 120W (S; also WIM), COMM 169 (W), MS&E 181 (S), MS&E 193 (A; also WIM), or POLISCI 114S (W).

* Make sure to schedule the appropriate prereqs (Coastal electives) for your desired Capstone class.

** Win Qtr abroad is easy for this focus area! See footnote to Focus Area page for which Overseas classes can count as electives. And some Overseas programs offer ENGR 40 or 50 (which could count as the 3rd ENGR Fund).

Environmental Systems Engineering -- Coastal focus

Spring Qtr Junior Year Abroad **

	Fall				Winter				Spring			
	Math/				Math/				Math/			
	Class	Sci.	Engr	Other	Class	Sci.	Engr	Other	Class	Sci.	Engr	Other
<i>Freshman</i>	MATH 41	5	-	-	MATH 42	5	-	-	CS106A	-	5	-
	<i>Unrstr Elctv #</i>	-	-	3	PHYSICS 41	4	-	-	<i>Unrstr Elctv #</i>	-	-	3
	<i>Unrstr Elctv #</i>	-	-	3	<i>Unrstr Elctv #</i>	-	-	3	WAYS +	-	-	4
	THINK	-	-	4	WAYS +	-	-	4	PWR1	-	-	4
	<i>Subtotals</i>	5	0	10	<i>Subtotals</i>	9	0	7	<i>Subtotals</i>	0	5	11
Total	15			Total	16			Total	16			
<i>Sophomore</i>	Language	-	-	5	Language	-	-	5	Language	-	-	5
	CHEM 31A ^{^^}	5	-	-	CHEM 31B ^{^^}	5	-	-	CEE101B	-	4	-
	ENGR90/CEE70	-	3	-	Engr Fund #	-	3	-	<i>Unrstr Elctv</i>	-	-	3
	WAYS +	-	-	3	<i>Unrstr Elctv #</i>	-	-	3	PWR2	-	-	4
	<i>Subtotals</i>	5	3	8	<i>Subtotals</i>	5	3	8	<i>Subtotals</i>	0	5	12
Total	16			Total	16			Total	17			
<i>Junior</i>	MATH 51 [^]	5	-	-	CEE164	-	3	-	WAYS +	-	-	5
	<u>Coastal Elctv</u>	-	3	-	<u>Coastal Elctv</u>	-	3	-	WAYS +	-	-	4
	Tools/Skills	-	3	-	Tools/Skills	-	3	-	<i>Unrstr Elctv</i>	-	-	5
	WAYS +	-	-	5	Prob/Stats. [^]	5	-	-	--- Spring Quarter Abroad --- **			
	<i>Subtotals</i>	5	6	5	<i>Subtotals</i>	5	9	0	<i>Subtotals</i>	0	0	14
Total	16			Total	14			Total	14			
<i>Senior</i>	<u>Coastal Elctv</u>	-	3	-	<u>Coastal Elctv</u>	-	3	-	CEE175A	-	3	-
	<u>Coastal Elctv</u>	-	3	-	Math/Sci	3	-	-	<u>Coastal Elctv</u>	-	3	-
	Capstone *	-	3	-	WAYS + ++	-	-	5	<u>Coastal Elctv</u>	-	3	-
	TiS ++	-	-	5	Tools/Skills	-	3	-	<i>Subtotals</i>	0	12	0
	<i>Subtotals</i>	0	9	5	<i>Subtotals</i>	3	6	5	Total	12		
Total	14			Total	14			Total	12			

Total Math & Science Units (min=36): 37

Total Eng.Fund.+Tools/Sk.+Focus Area Units (min=11+10+36=57): 58

Total Other Units: 85

Total Units (min=180): 180

Notes:

 ----- Courses in this row can be rearranged, e.g., to accommodate PWR or a Coastal elective in any quarter.

Students should explore majors of interest to them using these unrestricted electives. Classes accessible to Fresh/Sophs which count towards Coastal focus: CEE 70(A), BIO 12N(A), EARTHSYS 56Q(W), BIO 3N(S), BIO 30(S), EESS 8(S), CEE 50N(S).

^ Can take CME 100 instead of MATH 51. Can take MATH 53 or CME 102 instead of Probability/Stats.

^^ If CHEM 31X or ENGR 31 is taken, replace CHEM31B with an SoE-approved science/math class.

+ May need 7 WAYS courses outside of major requirements: 2 in Aesthetic/Interpretive Inquiry, 2 in Social Inquiry, 1 in Ethical Reasoning, 1 in Engaging Diversity, and 1 in Creative Expression.

++ Some TiS classes also fulfill a WAYS or WIM reqmt: For WAYS-ER, choose ENGR 131 (A,S) or MS&E 197 (W; also WIM); for WAYS-SI, choose COMM 120W (S; also WIM), COMM 169 (W), MS&E181 (S), MS&E193 (A; also WIM), or POLISCI 114S (W).

* Make sure to schedule the appropriate prereqs (Coastal electives) for your desired Capstone class.

** To do Spring Qtr Abroad, MUST take CEE101B in Spring of Soph year (or petition to take ME 70 in Win of Jr year as a substitute). See footnote to Focus Area page for which Overseas classes can count as electives. And some Overseas programs offer ENGR 40 or 50 (which could count as the 3rd Engr Fund).

Environmental Systems Engineering -- Urban focus

Autumn Qtr Junior Year Abroad **

	Fall			Winter			Spring					
	Math/ Sci.	Engr	Other	Class	Math/ Sci.	Engr	Other	Class	Math/ Sci.	Engr	Other	
<i>Freshman</i>	MATH 41	5	-	-	MATH 42	5	-	-	CS106A	-	5	-
	<i>Unrstr Elctv #</i>	-	-	3	PHYSICS 41	4	-	-	<i>Unrstr Elctv #</i>	-	-	3
	<i>Unrstr Elctv #</i>	-	-	3	<i>Unrstr Elctv #</i>	-	-	3	WAYS +	-	-	4
	THINK	-	-	4	WAYS +	-	-	4	PWR1	-	-	4
	<i>Subtotals</i>	5	0	10	<i>Subtotals</i>	9	0	7	<i>Subtotals</i>	0	5	11
Total	15			Total	16			Total	16			
<i>Sophomore</i>	Language	-	-	5	Language	-	-	5	Language	-	-	5
	MATH 51 [^]	5	-	-	WAYS +	-	-	5	PHYSICS 43 ^{^^}	4	-	-
	Engr Fund #	-	3	-	<u>Urban Elctv</u>	-	3	-	CEE 1	-	1	-
	WAYS +	-	-	4	<i>Unrstr Elctv #</i>	-	-	4	PWR2	-	-	4
	<i>Subtotals</i>	5	3	9	<i>Subtotals</i>	0	3	14	<i>Subtotals</i>	4	1	9
Total	17			Total	17			Total	14			
<i>Junior</i>	WAYS +	-	-	5	CEE 176A	-	4	-	CEE 101B	-	4	-
	WAYS +	-	-	4	Prob/Stats. [^]	5	-	-	Science/Math	4	-	-
	<i>Unrstr Elctv</i>	-	-	5	<u>Urban Elctv</u>	-	3	-	TiS ++	-	-	4
	--- Autumn Quarter Abroad --- **	-	-	-	Tools/Skills	-	3	-	Tools/Skills	-	3	-
	<i>Subtotals</i>	0	0	14	<i>Subtotals</i>	5	10	0	<i>Subtotals</i>	4	7	4
Total	14			Total	15			Total	15			
<i>Senior</i>	CEE 100 (WIM)	-	4	-	CEE 146A	-	3	-	<u>Urban Elctv</u>	-	3	-
	<u>Urban Elctv</u>	-	3	-	<u>Urban Elctv</u>	-	3	-	Science/Math	4	-	-
	<u>Urban Elctv</u>	-	3	-	<u>Urban Elctv</u>	-	3	-	Tools/Skills	-	3	-
	Capstone *	-	3	-	<i>Unrstr Elctv</i>	-	-	5	WAYS + ++	-	-	4
	<i>Subtotals</i>	0	13	0	<i>Subtotals</i>	0	9	5	<i>Subtotals</i>	4	6	4
Total	13			Total	14			Total	14			

Total Math & Science Units (min=36): 36

Total Eng.Fund.+Tools/Sk.+Focus Area Units (min=11+10+36=57): 57

Total Other Units: 87

Total Units (min=180): 180

Notes:

--- Courses in this row can be rearranged, e.g., to accommodate PWR or an Urban elective in any quarter.

Students should explore majors of interest to them using these unrestricted electives. Classes accessible to Fresh/Sophs that count towards Urban focus: APPLPHYS 79N(A), ME 16N(A), AA 116Q(A), CEE 100(A), CEE 29N(W), ECON 17N(W), CEE 156(W), URBANST 113(W), CEE 50N(S).

[^] Can take CME 100 instead of MATH 51. Can take MATH 53 or CME 102 instead of Probability/Stats.

^{^^} Can take CHEM 31A+B (or CHEM 31X or ENGR 31) instead of PHYSICS 43.

+ May need 7 WAYS courses outside of major requirements: 2 in Aesthetic/Interpretive Inquiry, 2 in Social Inquiry, 1 in Ethical Reasoning, 1 in Engaging Diversity, and 1 in Creative Expression.

++ Some TiS classes also fulfill a WAYS reqmt: For WAYS-ER, take ENGR 131(A,S) or MS&E 197(W); for WAYS-SI, choose COMM 120W(S), COMM 169(W), MS&E 181(S), MS&E 193(A), or POLISCI 114S(W).

* Make sure to schedule the appropriate prereqs (= Urban electives) for your desired Capstone class.

** Aut Qtr abroad is easy for this focus area! See footnote to Focus Area page for which Overseas classes can count as electives. And some Overseas programs offer ENGR 40 or 50 (which could count as the 3rd ENGR Fund).

Environmental Systems Engineering -- Urban focus

Winter Qtr Junior Year Abroad **

	Fall			Winter			Spring					
	Math/ Sci.	Engr	Other	Class	Math/ Sci.	Engr	Other	Class	Math/ Sci.	Engr	Other	
<i>Freshman</i>	MATH 41	5	-	-	MATH 42	5	-	-	CS106A	-	5	-
	<i>Unrstr Elctv #</i>	-	-	3	PHYSICS 41	4	-	-	<i>Unrstr Elctv #</i>	-	-	3
	<i>Unrstr Elctv #</i>	-	-	3	<i>Unrstr Elctv #</i>	-	-	3	WAYS +	-	-	4
	THINK	-	-	4	WAYS +	-	-	4	PWR1	-	-	4
	<i>Subtotals</i>	5	0	10	<i>Subtotals</i>	9	0	7	<i>Subtotals</i>	0	5	11
Total	15			Total	16			Total	16			
<i>Sophomore</i>	Language	-	-	5	Language	-	-	5	Language	-	-	5
	MATH 51 [^]	5	-	-	WAYS +	-	-	5	PHYSICS 43 ^{^^}	4	-	-
	Engr Fund #	-	3	-	<u>Urban Elctv</u>	-	3	-	CEE 1	-	1	-
	WAYS +	-	-	4	<i>Unrstr Elctv **</i>	-	-	4	PWR2	-	-	4
	<i>Subtotals</i>	5	3	9	<i>Subtotals</i>	0	3	14	<i>Subtotals</i>	4	1	9
Total	17			Total	17			Total	14			
<i>Junior</i>	CEE 100 (WIM)	-	4	-	WAYS +	-	-	5	CEE 101B	-	4	-
	Prob/Stats. [^]	5	-	-	WAYS +	-	-	4	Science/Math	4	-	-
	<u>Urban Elctv</u>	-	3	-	<i>Unrstr Elctv</i>	-	-	5	TiS ++	-	-	4
	Tools/Skills	-	3	-	<i>--- Winter Quarter Abroad --- **</i>				Tools/Skills	-	3	-
	<i>Subtotals</i>	5	10	0	<i>Subtotals</i>	0	0	14	<i>Subtotals</i>	4	7	4
Total	15			Total	14			Total	15			
<i>Senior</i>					CEE 146A	-	3	-				
	<u>Urban Elctv</u>	-	3	-	CEE176A	-	4	-	<u>Urban Elctv</u>	-	3	-
	<u>Urban Elctv</u>	-	3	-	<u>Urban Elctv</u>	-	3	-	Science/Math	4	-	-
	Capstone *	-	3	-	<u>Urban Elctv</u>	-	3	-	Tools/Skills	-	3	-
	<i>Unrstr Elctv</i>	-	-	5					WAYS + ++	-	-	4
	<i>Subtotals</i>	0	9	5	<i>Subtotals</i>	0	13	0	<i>Subtotals</i>	4	6	4
Total	14			Total	13			Total	14			

Total Math & Science Units (min=36): 36

Total Eng.Fund.+Tools/Sk.+Focus Area Units (min=11+10+36=57): 57

Total Other Units: 87

Total Units (min=180): 180

Notes:

----- Courses in this row can be rearranged, e.g., to accommodate PWR or an Urban elective in any quarter.

Students should explore majors of interest to them using these unrestricted electives. Classes accessible to Fresh/Sophs that count towards Urban focus: APPLPHYS 79N(A), ME 16N(A), AA 116Q(A), CEE 100(A), CEE 29N(W), ECON 17N(W), CEE 156(W), URBANST 113(W), CEE 50N(S).

^ Can take CME 100 instead of MATH 51. Can take MATH 53 or CME 102 instead of Probability/Stats.

^^ Can take CHEM 31A+B (or CHEM 31X or ENGR 31) instead of PHYSICS 43.

+ May need 7 WAYS courses outside of major requirements: 2 in Aesthetic/Interpretive Inquiry, 2 in Social Inquiry, 1 in Ethical Reasoning, 1 in Engaging Diversity, and 1 in Creative Expression.

++ Some TiS classes also fulfill a WAYS req't: For WAYS-ER, take ENGR 131(A,S) or MS&E 197(W); for WAYS-SI, choose COMM 120W(S), COMM 169(W), MS&E 181(S), MS&E 193(A), or POLISCI 114S(W).

* Make sure to schedule the appropriate prereqs (= Urban electives) for your desired Capstone class.

** One drawback to Win Qtr abroad: Many Urban electives are Win qtr. Might want to take a 2nd Urban elective Win qtr of Soph Year. See footnote to Focus Area page for which Overseas classes can count as electives. And some Overseas programs offer ENGR 40 or 50 (which could count as the 3rd ENGR Fund).

Environmental Systems Engineering -- Urban focus

Spring Qtr Junior Year Abroad **

	Fall			Winter			Spring					
	Math/ Sci.	Engr	Other	Class	Math/ Sci.	Engr	Other	Class	Math/ Sci.	Engr	Other	
<i>Freshman</i>	MATH 41	5	-	-	MATH 42	5	-	-	CS106A	-	5	-
	<i>Unrstr Elctv #</i>	-	-	3	PHYSICS 41	4	-	-	PHYSICS 43 ^{^^}	4	-	-
	<i>Unrstr Elctv #</i>	-	-	3	<i>Unrstr Elctv #</i>	-	-	3	WAYS +	-	-	3
	THINK	-	-	4	WAYS +	-	-	4	PWR1	-	-	4
	<i>Subtotals</i>	5	0	10	<i>Subtotals</i>	9	0	7	<i>Subtotals</i>	4	5	7
Total	15			Total	16			Total	16			
<i>Sophomore</i>	Language	-	-	5	Language	-	-	5	Language	-	-	5
	MATH 51 [^]	5	-	-	WAYS +	-	-	5	CEE101B **	-	4	-
	Engr Fund #	-	3	-	<u>Urban Elctv</u>	-	3	-	CEE 1	-	1	-
	WAYS +	-	-	4	<i>Unrstr Elctv #</i>	-	-	4	PWR2	-	-	4
	<i>Subtotals</i>	5	3	9	<i>Subtotals</i>	0	3	14	<i>Subtotals</i>	0	5	9
Total	17			Total	17			Total	14			
<i>Junior</i>	CEE 100 (WIM)	-	4	-	CEE 176A	-	4	-	WAYS +	-	-	5
	Science/Math	4	-	-	Prob/Stats. [^]	5	-	-	WAYS +	-	-	4
	TiS ++	-	-	4	<u>Urban Elctv</u>	-	3	-	<i>Unrstr Elctv</i>	-	-	5
	Tools/Skills	-	3	-	Tools/Skills	-	3	-	--- Spring Quarter Abroad --- **			
	<i>Subtotals</i>	4	7	4	<i>Subtotals</i>	5	10	0	<i>Subtotals</i>	0	0	14
Total	15			Total	15			Total	14			
<i>Senior</i>					CEE 146A	-	3	-				
	<u>Urban Elctv</u>	-	3	-	<u>Urban Elctv</u>	-	3	-	<u>Urban Elctv</u>	-	3	-
	<u>Urban Elctv</u>	-	3	-	<u>Urban Elctv</u>	-	3	-	Science/Math	4	-	-
	Capstone *	-	3	-	<i>Unrstr Elctv</i>	-	-	5	Tools/Skills	-	3	-
	<i>Unrstr Elctv</i>	-	-	5	<i>Subtotals</i>	0	9	5	<i>Subtotals</i>	4	6	3
Total	14			Total	14			Total	13			

Total Math & Science Units (min=36): 36

Total Eng.Fund.+Tools/Sk.+Focus Area Units (min=11+10+36=57): 57

Total Other Units: 87

Total Units (min=180): 180

Notes:

--- Courses in this row can be rearranged, e.g., to accommodate PWR or an Urban elective in any quarter.

Students should explore majors of interest to them using these unrestricted electives. Classes accessible to Fresh/Sophs that count towards Urban focus: APPLPHYS 79N(A), ME 16N(A), AA 116Q(A), CEE 100(A), CEE 29N(W), ECON 17N(W), CEE 156(W), URBANST 113(W), CEE 50N(S).

[^] Can take CME 100 instead of MATH 51. Can take MATH 53 or CME 102 instead of Probability/Stats.

^{^^} Can take CHEM 31A+B (or CHEM 31X or ENGR 31) instead of PHYSICS 43.

+ May need 7 WAYS courses outside of major requirements: 2 in Aesthetic/Interpretive Inquiry, 2 in Social Inquiry, 1 in Ethical Reasoning, 1 in Engaging Diversity, and 1 in Creative Expression.

++ Some TiS classes also fulfill a WAYS req't: For WAYS-ER, take ENGR 131(A,S) or MS&E 197(W); for WAYS-SI, choose COMM 120W(S), COMM 169(W), MS&E 181(S), MS&E 193(A), or POLISCI 114S(W).

* Make sure to schedule the appropriate prereqs (= Urban electives) for your desired Capstone class.

** To do Spring Qtr Abroad, should take CEE 101B in Spring of Soph year (or petition to take ME 70 in Win of Jr year as a substitute). See footnote to Focus Area page for which Overseas classes can count as electives. And some Overseas programs offer ENGR 40 or 50 (which could count as the 3rd ENGR Fund).

INSTRUCTIONS FOR DECLARING MAJOR IN ENVIRONMENTAL SYSTEMS ENGINEERING

1. Enter your major declaration as Environmental Systems Engineering in **Axess**
2. Pick up your academic folder from your pre-major adviser and print out your Stanford transcript (unofficial is fine) from **Axess**.
3. Download and complete your major **Program Sheet**, which you can obtain from the UGHB website at <http://ughb.stanford.edu/>. Be sure to fill in all courses that you have taken and those that you plan to take. You will have the opportunity to revise your Program Sheet later, so please fill in as many courses as you can.
4. Bring your transcript and completed program sheet to the CEE Student Services office in Room 316 of the Jerry Yang and Akiko Yamazaki Environment & Energy [Y2E2] Building and request to have an ESE advisor assigned to you. You may request a specific advisor if you wish. Office hours are 10:00 am to noon and 2:00 to 4:00 pm, Monday through Friday.
5. Meet with your Environmental Systems Engineering undergraduate advisor and have him/her review and sign your program sheet.
6. Return your signed program sheet to the CEE Student Services Specialist, who upon receiving your signed sheet will approve your major declaration in Axess.
7. You are encouraged to meet with your CEE undergraduate adviser at least once a quarter to review your academic progress. Changes to your program sheet can be made by printing out a revised sheet, obtaining your undergraduate adviser's signature, and returning the approved sheet to the CEE Student Services Office. **NOTE – *Confirm that your program sheet is up to date at least one quarter prior to graduation.***
8. Other information:
 - Procedures for requesting transfer credits and program deviations are described in detail in at the beginning of Chapter 4: "Policies and Procedures." The relevant forms are in the back of the Handbook in the "Forms" section, or on the UGHB site under the "Petitions" link. The online forms may be filled out electronically. If you are requesting transfer credits or program deviations, you should bring your completed petition form with your transcript to the CEE Student Services office. Attach your program sheet on file in CEE.
 - Check with the CEE Student Services Office to make sure that you are on the CEE UG student email list for important announcements about department events and activities.

Note: The online version of your major (link from the Home or Major Programs page of the UGHB website) is considered the definitive version of 2014-15 requirements; corrections or updates may have been made after the printed and pdf versions were published in August 2014.

★ You must use a program sheet from a year you have been enrolled at Stanford.

Environmental Systems Engineering Program Sheet (continued)

Engineering Topics

Dept	Course	Title	Transfer/AP Approval by SoE			Unit	Grade
			✓ if Transfer	SoE Initials	Date	Total	
<i>Engineering Fundamentals (3 courses required)</i>							
ENGR	70A	Programming Methodology (req'd) (same as ENGR 70X)				5	
ENGR		ENGR 90 for Freshwater or Coastal focus; CEE146A for Urban focus				3	
ENGR		<i>Fundamentals Elective (cannot count ENGR 70B or X)</i>				3 to 5	
<i>Engineering Fundamentals Unit Total</i>							

Fundamental Tools/Skills (10 units required)

CEE	1	Introduction to Environmental Systems Engineering (req'd)				1	
		At least 1 Visual Communication class from list (see Note 2)					
		At least 1 Oral/Written Communication class from list (see Note 2)					
		At least 1 Modeling/Analysis class from list (see Note 2)					
<i>Tools/Skills Unit Total (minimum 10 units)</i>							

Focus Area (36 units req'd; see Note 3)

◆ Indicate Focus Area: Urban or Freshwater or Coastal: _____

CEE	101B	Mechanics of Fluids (req'd)				4	
CEE			(Req'd #2)				
CEE			(Req'd #3)				
<i>Focus Area Unit Total (minimum 36 units)</i>							

- (2) For a list of course options see the Fundamental Tools/Skills chart in the UGHB, EnvSE section, or at http://web.stanford.edu/group/ughb/cgi-bin/handbook/index.php/Environmental_Systems_Engineering_Program
- (3) Focus Area requirements are listed in the UGHB, EnvSE section, or at http://web.stanford.edu/group/ughb/cgi-bin/handbook/index.php/Environmental_Systems_Engineering_Program

Program Approvals

Advisor

Printed Name: _____ Date: _____

Signature: _____

Departmental

Printed Name: _____ Date: _____

Signature: _____

School of Engineering (No action required-office use only)

Printed Name: _____ Date: _____

Signature: _____

INDIVIDUALLY DESIGNED MAJOR IN ENGINEERING

Individually Designed Majors in Engineering (IDMENs) are intended for undergraduates interested in studying engineering in areas not covered by departmental majors or the pre-approved School of Engineering sub-plans. Each IDMEN curriculum is designed by the student in consultation with at least two faculty advisors. Each student's primary academic advisor must be a member of the Stanford Academic Council, which means that Lecturers and Visiting Professors cannot fill this role. Students must also have a secondary advisor; this faculty member can be a member of a Stanford School other than Engineering and need not necessarily be a member of the Stanford Academic Council. The purpose of requiring a second advisor is to ensure that the student receives sufficient guidance about aspects of the proposed course of study that may lie outside the field of expertise of the primary advisor. The IDMEN degree is designated as a "Bachelor of Science in an Individually Designed Major in Engineering: *Approved Title*." This degree program is not accredited by ABET (see section on Accreditation for more information).

To pursue an IDMEN, a student must have at least four quarters of undergraduate work remaining at Stanford after the quarter in which their proposals are submitted, and the IDMEN may not be your secondary major.

Submit a written proposal to the IDMEN Subcommittee of the Undergraduate Council detailing your proposed course of study; you may bring your proposal to 135 Huang. IDMEN programs must meet the general minimum requirements established for School of Engineering majors:

- 21 units of mathematics (see SoE-approved course list in Chap 3, Fig 3-1)
- 17 units of science (see SoE-approved course list in Chap 3, Fig 3-2)
- One course on Technology in Society (see SoE-approved course list in Chap 3, Fig 3-3)
- 40 units of School of Engineering courses, at least three of which must be Engineering Fundamentals courses (see approved course list in Chap 3, Fig 3-4), and 31 units of which must be Engineering depth courses
- Additional courses to bring the total to at least 90 but not more than 107 units

Each proposal must contain the following four elements:

1. **Rationale.** The proposal should begin with a carefully crafted statement that describes the major, characterizes the proposer's motivation for pursuing it, justifies it intellectually, indicates the proposer's ultimate goal and how the major relates to it, shows how the courses comprising its curriculum make sense given its purpose, and tells why this plan of study cannot be pursued in any existing School of Engineering major program. A proposed title for the major, the accepted version of which will be shown on the student's diploma and transcript, should be included. Sample proposals are available for review in the Office of Student Affairs, 135 Huang.
2. **IDMEN program sheet.** This form can be accessed as an Excel spreadsheet on the web at <http://ughb.stanford.edu>, and should be filled out completely including an indication of which course the student intends to take to fulfill the university's Writing in the Major (WIM) requirement. The bottom of the second page of the IDMEN program sheet must be signed by two faculty members: the student's primary advisor, who **must** be an Academic Council member of the School of Engineering faculty, and a secondary advisor. These signatures certify that the advisors endorse the major as described in the proposal and agree to serve as permanent advisors.
3. **Four-year plan.** This blank form is available for download on the web at <http://ughb.stanford.edu>. The courses listed as part of the plan should comprise a well-coordinated sequence that fosters mastery of the important principles and techniques in a well-defined field.
4. **Letter of support.** A letter of support from the student's primary advisor appraising the academic value and viability of the proposed major and the student's ability to successfully complete it must accompany the Proposal.

Proposals are reviewed and acted upon once per quarter (fall, winter, and spring only) by the IDMEN subcommittee. Proposals should be submitted to the Office of Student Affairs (OSA) in 135 Huang. Deadlines for proposal submission this year are:

Autumn Quarter: October 24, 2014

Winter Quarter: February 6, 2015

Spring Quarter: May 1, 2015

If the reviewing committee has questions or concerns about your proposed program, they will contact you and ask for clarification or specific changes. Once the proposal has been accepted by the reviewing committee the School of Engineering OSA will notify you via email. See instructions on the next page for how to declare. Once an IDMEN program is approved, any

changes must be petitioned, receiving endorsement from both faculty advisors and by the IDMEN Subcommittee.

Further information and assistance in preparing proposals are available from the Office of Student Affairs, 135 Huang. **Students are strongly encouraged to read “School of Engineering/Individually Designed Majors,” a handout prepared by the Undergraduate Council for students interested in the IDMEN alternative. This handout is available from the Office of Student Affairs in 135 Huang.**

INSTRUCTIONS FOR DECLARING AN INDIVIDUALLY DESIGNED MAJOR

1. Investigate existing majors to determine whether your goals can be met by pursuing a pre-defined major. It is important to gather information about the majors and their options by talking to students and professors.
2. If you decide to pursue an individually designed major, talk to faculty members to get their advice. Identify two Stanford faculty members who can serve as advisors, and select one as your "primary" advisor.
 - a. The primary advisory must be within the School of Engineering and must be a member of the Stanford Academic Council, which means that Lecturers and Visiting Professors cannot fill this role.
 - b. The secondary advisor need not be a member of the Academic Council, and may be outside of the School of Engineering.
3. Work with your advisors to design a proposal (as described on previous section page), including the following materials:
 - a. A rationale statement describing the proposed major
 - b. An Individually Designed Major program sheet (on Program Sheets page of the UGHB website: ughb.stanford.edu)
 - c. A four-year plan listing the courses you intend to take (at ughb.stanford.edu)
 - d. A letter of support from your advisor
4. Submit the proposal package in the SoE Office of Student Affairs (OSA), 135 Huang. See IDMEN major description for quarterly deadlines.
5. When your major has been reviewed, you will either receive an email of approval or be given some guidelines to modify your major in order to satisfy the reviewing committee.
6. Once your IDMEN is approved, download the "Declaration or Change of Undergraduate, Major, Minor, Honors" form from the Registrar website at http://studentaffairs.stanford.edu/sites/default/files/registrar/files/change_UG_program.pdf
7. Complete the form, selecting the IDMEN box and entering your approved title. The form must be signed by you and by the OSA office before submission to the SSC.

Stanford University ♦ School of Engineering
Individually Designed Major in Engineering

Title: _____

2014–2015 Program Sheet

Follow all requirements as stated for the year of the program sheet used.

Name: _____ SU ID #: _____
 Phone: _____ Email: _____
 Today's Date: _____ Month/Yr B.S. expected: _____

Dept	Course	Title	Transfer/AP Approval			Units	Grade
			✓ if Transfer	Initials	Date		
Mathematics (21 units minimum required; see UGHB Fig. 3-1 for approved courses)							
<i>Mathematics Total</i>							

Science (17 units minimum required; see UGHB Fig. 3-2 for approved courses)

<i>Science Total</i>							

Technology in Society (1 course required; see UGHB Fig. 3-3 for approved list)

--	--	--	--	--	--	--	--

GENERAL NOTES

- 1) To declare your IDMEN major, the following materials must accompany this Program Sheet: Written proposal, 4-Year Plan, letter of support from Primary Advisor, and an unofficial Stanford transcript.
- 2) This form is available as an Excel or pdf file at ughb.stanford.edu. The printed form must be signed by the advisor. Changes must be initialed in ink.
- 3) All courses listed on this form must be taken for a **letter grade** if offered by the instructor. Minimum Grade Point Average (GPA) for all courses in Engineering Fundamentals and Engineering Depth (combined) is a 2.0.
- 4) All transfer and AP credits must be approved by the SoE Dean's office. Transfer credits in Engineering Depth must be approved by the Primary Advisor.
- 5) Program must include a course approved to fulfill the "Writing in the Major" requirement.

program sheet continues on page 2

Individually Designed Major cont.

Engineering Fundamentals (3 courses required)

<i>Engineering Fundamentals Total (3 courses required)</i>							

Engineering Depth (31 units minimum)

Dept	Course	Title	Transfer/AP Approval			Unit	Grade
			✓ if Transfer	Initials	Date		
<i>Engineering Depth Total</i>							

Additional Courses (as necessary to bring program totals to at least 90 but not more than 107 units)

<i>Engineering Courses (Funds + Depth) Total (40 minimum)</i>							
<i>Totals from previous page</i>							
<i>Program Totals</i>							

Primary Advisor

Printed Name: _____

Date: _____

Signature: _____

Secondary Advisor

Printed Name: _____

Date: _____

Signature: _____

School of Engineering Approval (No action required-office use only)

Printed Name: _____

Date: _____

Signature: _____

MANAGEMENT SCIENCE AND ENGINEERING

The Department of Management Science and Engineering is concerned with how best to organize resources – people, money, and materials – in our information-intensive, technology-based economy. The degree programs in MS&E prepare students to solve practical problems based on fundamental engineering principles. The department has strong research and teaching programs in decision and risk analysis, economics, engineering management, entrepreneurship, finance, information, operations research, organizations, production and manufacturing, strategy, systems analysis, and technology policy.

The undergraduate curriculum in Management Science and Engineering provides students training in the fundamentals of engineering systems analysis to prepare them to plan, design, and implement complex economic and technological management systems where a scientific or engineering background is necessary or desirable. Graduates will be prepared for work in a variety of career paths, including facilities and process management, investment banking, management consulting, or graduate study in industrial engineering, operations research, economics, public policy, medicine, law, or business.

OBJECTIVES AND OUTCOMES FOR MANAGEMENT SCIENCE & ENGINEERING

Objectives:

Principles and Skills: Provide our students with a basic understanding of management science and engineering principles, including analytical problem solving and communication skills.

Preparation for Practice: Prepare our students for practice in a field that sees rapid changes in tools, problems, and opportunities.

Preparation for Continued Growth: Prepare our students for graduate study and self development over an entire career, and

Preparation for Service: Develop in our students the awareness, background, and skills necessary to become responsible citizens, employees, and leaders

Outcomes:

An ability to apply knowledge of math, science, and engineering;

An ability to design and conduct experiments;

An ability to design a system or components to meet desired needs;

An ability to identify, formulate, and solve engineering problems;

An ability to use techniques, skills, and modern engineering tools necessary for engineering practice;

An ability to function on multidisciplinary teams;

An ability to communicate effectively;

A recognition of the need for and an ability to engage in life-long learning;

Background necessary for admission to top professional graduate engineering or business programs;

An understanding of professional and ethical responsibility;

The broad education necessary to understand the impact of engineering solutions in a global and societal context; and

A knowledge of contemporary issues pertinent to the field of management science and engineering.

PROGRAM DESCRIPTION

The program builds on the foundational courses for engineering, including calculus, mathematical modeling, probability, statistics, engineering fundamentals, and physics or chemistry. The department core, taken for all areas, includes courses in accounting, computer science, deterministic optimization, economics, organization theory, and a capstone senior project. Through the core, all students in the program are exposed to the breadth of faculty interests, and are in a good position to choose an area during the junior year.

The major is designed to allow a student to explore all three areas of the department in greater depth.

1. *Financial and Decision*: focuses on the design and analysis of financial and strategic plans.
2. *Operations and Analytics*: focuses on algorithms, theory, and the design and analysis of manufacturing, production, and service systems.
3. *Organizations, Technology, and Policy*: focuses on understanding, design, and analysis of organizations and public policy, particularly technology-based issues.

The program for students in all concentrations builds on a strong engineering foundation. The required mathematics courses include calculus of single and multiple variables, linear algebra, probability, statistics, and stochastic models. At least eleven units of science are required, including two courses in chemistry or physics. The required and elective mathematics and science requirements can be met by the approved courses, listed earlier in this handbook, or by PHYSICS 21, 22, 23, 24, 25, or 26, PSYCH 50 (cognitive neuroscience) or 70 (social psychology), or AP credit for chemistry, mathematics, or physics (AP units must be approved by the SoE Dean's office in 135 Huang).

The program includes three Engineering Fundamental courses in addition to the engineering fundamental course included in the department core, MS&E 111/ENGR 62. One of the fundamentals must be CS 106A, one is elective, and the other is either ENGR 40, 40A, 40M, or 40P, which provides some background and lab experience in electrical engineering, ENGR 25B or 25E, which presents basic science and engineering principles of biotechnology, or ENGR 80, which provides an overview of biological engineering focused on engineering analysis and design of biological processes.

The Technology in Society requirement is satisfied by a subset of the courses approved by the School of Engineering, particularly those that emphasize social responsibility (refer to the TIS table in this section or the asterisked items in Chapter 3, Figure 3-3). Some of these courses are

also included in some of the concentrations; any given course can be used to satisfy either the Technology in Society or depth requirement, but not both.

The Writing in the Major (WIM) requirement can be met by three restricted electives in the program, MS&E 152W, 193, or 197. It is up to the students to ensure that their programs include at least one of them, either in their area selections or their Technology in Society course. Students are welcome to take more than one WIM course, and WIM courses may be used to satisfy other requirements.

The department core comprises courses in computer science, deterministic optimization, information, organization theory, a senior project, and finance or production. Students in Financial and Decision Engineering must take two finance courses including MS&E 142. Students in Production and Operations Management must take MS&E 260. Students in Operations Research must take both MS&E 142 and MS&E 260.

Some of the concentrations include courses with prerequisites (ECON 1 or PSYCH 1) not included in the degree program, but those courses may be used to satisfy University Requirements.

Although there are prerequisites for most MS&E courses, we encourage students to take some MS&E courses in their freshman and sophomore year to learn more about the department. Introductory courses without prerequisites include MS&E 107, 140, 152, 178, 180, 181, 193, and 472. Introductory courses with calculus prerequisites include: MS&E 111, and MS&E 120.

For information about an MS&E minor, see the “Minors and Honors” section in this Handbook. In addition to the B.S. degree, the MS&E Department offers Master of Science and Doctor of Philosophy degrees in Management Science and Engineering.

If you would like more information about our degree programs, please visit Lori Cottle, the MS&E Student Services Manager, in Huang Engineering Center, Suite 114. Students are encouraged to plan their academic programs as early as possible, ideally in the freshman or sophomore year. Please do not wait until you are declaring a major to consult with us. This is particularly important if you would like to study overseas or pursue another major or minor.

RESEARCH EXPERIENCE FOR UNDERGRADUATES

Our Research Experience for Undergraduates (REU) program offers students the opportunity to work closely with a faculty member during the summer quarter, and get paid to do so full-time. We give priority to our declared majors for REU positions. Information is emailed to all declared majors when applications become available during the winter quarter.

REQUIREMENTS: BACHELOR OF SCIENCE DEGREE IN MS&E MATH AND SCIENCE* (44 UNITS MINIMUM)

COURSE	TITLE	UNITS	QTR.
MATH (all listed courses; 23 units minimum)			
CME 100	. Vector Calculus for Engineers	5	A,S
or MATH 51	Linear Algebra and Diff. Calculus of Several Variables	5	A,W,S
CME 103	Introduction to Matrix Methods (same as EE 103)	5	A
MS&E 120	Probabilistic Analysis	5	A
MS&E 121	Introduction to Stochastic Modeling	4	W
MS&E 125	Introduction to Applied Statistics	4	S

SCIENCE (8 units minimum)			
<i>One of the following three 8-10-unit sequences:</i>			
CHEM 31B/X	Chemical Principles (AP/IB credit may be used)	5	A,W
and CHEM 33	Structure and Reactivity	5	W,S
PHYSICS 21&22	Mechanics and Heat & Lab (AP/IB credit may be used)	4	A
and PHYSICS 23&24	Electricity and Optics & Lab (AP/IB credit may be used)	4	W
PHYSICS 41	Mechanics (AP Physics C /IB credit may be used)	4	W
& PHYSICS 43	Electricity and Magnetism (AP Physics C/IB credit may be used)	4	S
<i>And also:</i> Science Elective from SoE approved list (Fig. 3-2), or PSYCH 50, or PSYCH 70		3	A,W,S

Plus additional Math or Science electives (from the SoE-approved lists, or PSYCH 50 or 70) to reach 44 total units,.

* Electives may not repeat material from any other requirement. AP/IB credit for Chemistry, Mathematics, and Physics may be used.

TECHNOLOGY IN SOCIETY (ONE COURSE, 3-5 UNITS)

COURSE	TITLE	UNITS	QTR.
COMM 120W	Digital Media in Society	5	Not offered 2014-15
CS 181	Computers, Ethics, and Public Policy	3-4	S
ENGR 130	Science, Technology, and Contemporary Society	4	Not offered 14-15
ENGR 131	Ethical Issues in Engineering	4	A,S
MS&E 181	Issues in Technology and Work for a Post-Industrial Economy	3	S
MS&E 193	Technology in National Security	3	A
MS&E 197	Ethics and Public Policy	5	W
STS 1	The Public Life of Science and Technology	5	W

ENGINEERING FUNDAMENTALS (AT LEAST 3 COURSES; 11-15 UNITS)

COURSE	TITLE	UNITS	QTR.
CS 106A	Programming Methodologies (AP/IB credit may be used)	5	A,W,S
ENGR 25B/E	Biotechnology/Energy	3	S/W
<i>or one of</i> ENGR 40	Introductory Electronics <i>or</i>	5	W
<i>or</i> ENGR 40A	Introductory Electronics (3-unit, 7-week version) <i>or</i>	3	W
<i>or</i> ENGR 40M	An Intro to Making: What is EE <i>or</i>	5	A,S
<i>or</i> ENGR 40P	Physics of Electrical Engineering (same as EE 41)		N/O
<i>or</i> ENGR 80	Introduction to Bioengineering	4	S
One other engineering fundamental from SoE approved list (E62 may not be used)		3-5	A,W,S

WRITING IN THE MAJOR (ONE COURSE)

MS&E 152W, MS&E 193, or MS&E 197, taken as TIS or depth, fulfill the WIM requirement.

ENGINEERING DEPTH: CORE (6 COURSES; 28 UNITS)

COURSE	TITLE	UNITS	QTR.
CS 106B/X or CS 103	Programming Abstractions Mathematical Foundations of Computing	5 3-5	A,W,S A,W,S
ECON 50	Economic Analysis I	5	A,W
MS&E 108	Senior Project	5	W
MS&E 111	Introduction to Optimization	4	A,S
MS&E 140 <i>or</i> MS&E 140X	Accounting for Managers and Entrepreneurs Financial Accounting Concepts and Analysis	3-4 2	A,W S
MS&E 180	Organizations: Theory and Management	4	A,S

ENGINEERING DEPTH: AREA COURSES (27 UNITS)

Choose four or five courses (minimum 15 units) from a primary area and two courses (minimum 6 units) from each of the other two Areas.

FINANCIAL AND DECISION AREA (6-15 UNITS)

COURSE	TITLE	UNITS	QTR.
<i>Students choosing F&D as their primary area must take at least two of <u>ECON 51</u>, <u>MS&E 145</u>, and <u>MS&E 152</u></i>			
Introductory (appropriate for freshman and sophomores):			
MS&E 145	Introductory Financial Analysis	3	A
MS&E 152	Introduction to Decision Analysis (WIM)	4	S
Intermediate (appropriate for juniors and seniors):			
MS&E 146	Corporate Financial Management	4	W
MS&E 245G	Finance I	3	W
MS&E 252	Decision Analysis I: Foundations of Decision Analysis	3-4	A
Advanced (intended primarily for graduate students):			
ENGR 245A	Investment Science	3	A
MS&E 245B	Advanced Investment Science	3	W
MS&E 250A	Engineering Risk Analysis	3	W
MS&E 250B	Project Course in Engineering Risk Analysis	3	S

OPERATIONS AND ANALYTICS AREA (6-15 UNITS)

COURSE	TITLE	UNITS	QTR.
Students choosing O&A as their primary area may also include <u>CS 161</u> , <u>CS 229</u> , and <u>STATS 202</u> in their selections			
Introductory (no prerequisites):			
MS&E 107	Interactive Management Science	3	A
Methods			
MS&E 223	Simulation	3	S
MS&E 226	“Small” Data	3	S
MS&E 251	Stochastic Control	3	S
Applications			
MS&E 260	Introduction to Operations Management	3-4	A
MS&E 262	Supply Chain Management	3	S
MS&E 263	Healthcare Operations Management	3	A
MS&E 264	Sustainable Product Development and Manufacturing	3-4	A
MS&E 268	Operations Strategy	3	S

ORGANIZATIONS, TECHNOLOGY, AND POLICY AREA (6-15 UNITS)

COURSE	TITLE	UNITS	QTR.
Students choosing OT&P as their primary area must take at least two of <u>ENGR 145</u> , <u>MS&E 175</u> , <u>MS&E 181</u> , <u>MS&E 185</u> , <u>PSYCH 70</u> , and <u>SOC 114</u> (but not both <u>PSYCH 70</u> and <u>SOC 114</u>)			
Introductory (no prerequisites)			
ENGR 131	Ethical Issues in Engineering	4	A,S
MS&E 178	The Spirit of Entrepreneurship	3	A,W,S
MS&E 189	Social Networks	3	A
MS&E 190	Policy and Strategy Analysis	3	S
MS&E 193	Technology and National Security	3	A
MS&E 197	Ethics and Public Policy	5	W
Advanced (has prerequisites and/or appropriate for juniors and seniors)			
ENGR 145	Technology Entrepreneurship	4	A,W
MS&E 175	Innovation, Creativity, and Change	3-4	W
MS&E 177	Engineering Innovation	4	A
MS&E 181	Issues in Technology and Work	3	S
MS&E 185	Global Work	4	W,S
MS&E 243	Energy and Environmental Policy Analysis	3	S
MS&E 294	Climate Policy Analysis	3	Not offered 14-15
MS&E 295	Energy Policy Analysis	3	W
MS&E 243	Energy and Environmental Policy Analysis	3	S

Engineering fundamentals, engineering depth (core), and engineering depth (concentration) must total a minimum of 60 units.

Courses used to satisfy the math, science, technology in society, or engineering fundamental requirements may not also be used to satisfy an engineering depth requirement.

Management Science & Engineering

Typical Sequence of Courses

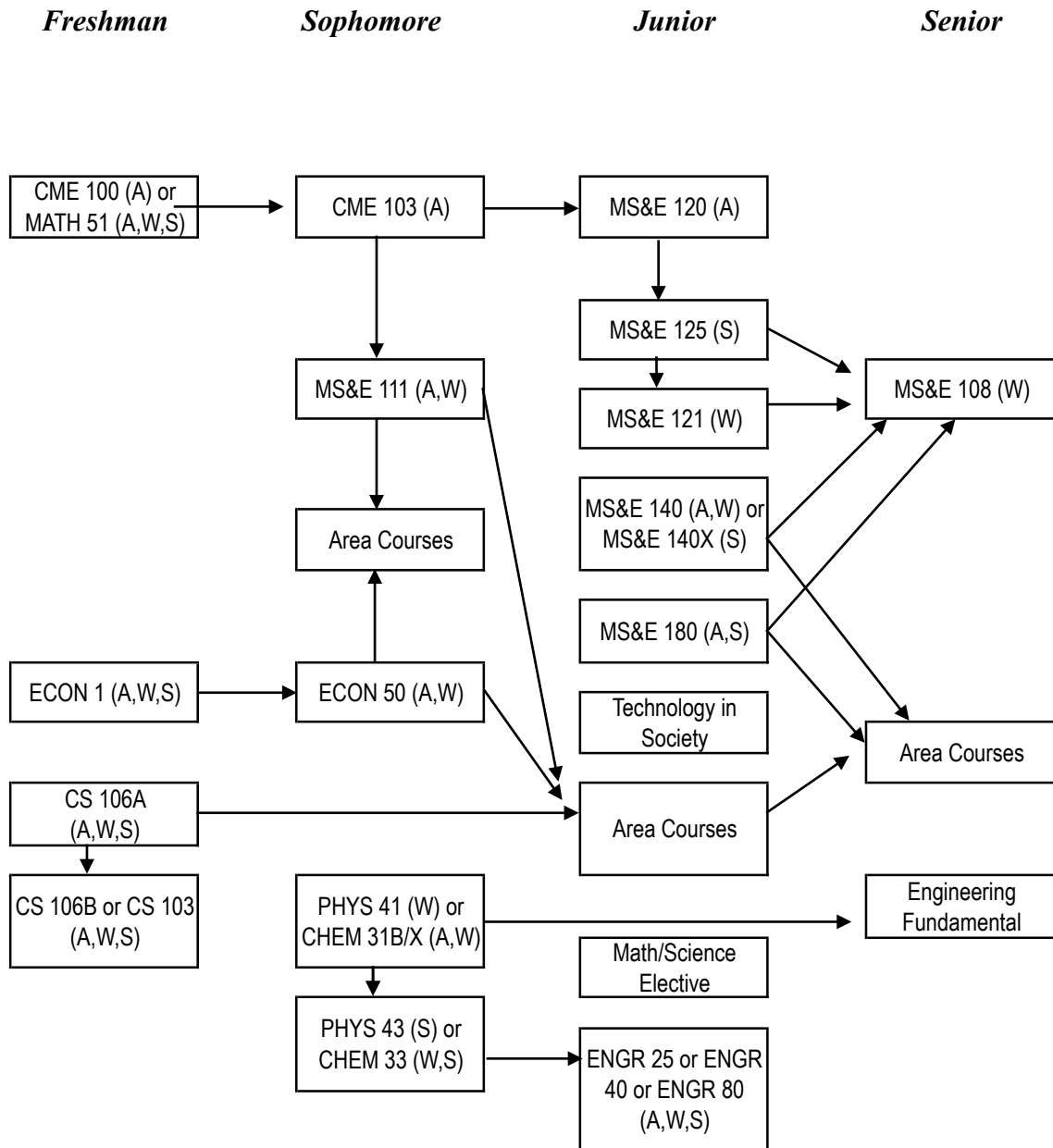

* Arrows represent direct prerequisites

Management Science & Engineering

Sample Program With AP/IB Math Credit

	<i>Fall</i>				<i>Winter</i>				<i>Spring</i>			
	Math/ Sci.	Engr	Other		Math/ Sci.	Engr	Other		Math/ Sci.	Engr	Other	
<i>Freshman</i>	Class				Class				Class			
	THINK	-	-	4	INTRO SEM	-	-	4	Language/THINK	-	-	5
	CME 100	5	-	-	Language/WAY*	-	-	5	PWR 1	-	-	4
	CS 106A	-	5	-	CS 103/106B	-	5	-	ECON 1	-	-	5
	<i>Subtotals</i>	5	5	4	<i>Subtotals</i>	0	5	9	<i>Subtotals</i>	0	0	14
	Total	14			Total	14			Total	14		
<i>Sophomore</i>	Language/WAY*	-	-	5	PWR 2/WAY*	-	-	4	PWR 2/WAY*	-	-	4
	CME 103	5	-	-	PHYSICS 41	4	-	-	PHYSICS 43	4	-	-
	ECON 50	-	5	-	MS&E 140	-	4	-	MS&E 111/180	-	4	-
	MS&E 472	-	-	1	Area	-	3	-	Area	-	3	-
	<i>Subtotals</i>	5	5	6	<i>Subtotals</i>	4	7	4	<i>Subtotals</i>	4	7	4
	Total	16			Total	15			Total	15		
<i>Junior</i>	MS&E 120	5	-	-	MS&E 121	4	-	-	MS&E 125	4	-	-
	MS&E 111/180	-	4	-	TIS/Area	-	3	-	MATH/SCI Elective	3	-	-
	TIS/Area	-	3	-	Area	-	4	-	E25/E40/E80	-	3	-
	WAY*/Elective	-	-	4	WAY*/Elective	-	-	4	TIS/Area	-	4	-
	<i>Subtotals</i>	5	7	4	<i>Subtotals</i>	4	7	4	<i>Subtotals</i>	7	7	0
	Total	16			Total	15			Total	14		
<i>Senior</i>	Fundamental Elec	-	3	-	MS&E 108	-	5	-	Area/Elective	-	3	-
	Area	-	4	-	Area	-	3	-	Electives	-	-	13
	WAY*/Elective	-	-	4	WAY*/Elective	-	-	4				
	Elective	-	-	4	Elective	-	-	4				
	<i>Subtotals</i>	0	7	8	<i>Subtotals</i>	0	8	8	<i>Subtotals</i>	0	3	13
	Total	15			Total	16			Total	16		

Total Math & Science Units: 34

Total Engineering Units: 68

Total Other Units: 78

Total Units: 180

*MS&E majors automatically satisfy: WAY-AQR (MS&E 120), WAY-FR (CME 100 or MATH 51), WAY-SI (ECON 1, ECON 50, and some TiS); but need to be sure to satisfy: WAY-All (x2), WAY-CE, WAY-ED, WAY-ER (some TiS), and WAY-SMA (x2) (science and some engineering fundamentals).

Management Science & Engineering

Sample Program Without AP/IB Math Credit

	<i>Fall</i>				<i>Winter</i>				<i>Spring</i>			
	Class	Math/ Sci.	Engr	Other	Class	Math/ Sci.	Engr	Other	Class	Math/ Sci.	Engr	Other
<i>Freshman</i>	THINK	-	-	4	INTRO SEM	-	-	4	Language/THINK	-	-	5
	MATH 41	5	-	-	Language/WAY*	-	-	5	PWR 1	-	-	4
	ECON 1	-	-	5	MATH 42	5	-	-	MATH 51	5	-	-
	<i>Subtotals</i>	5	0	9	<i>Subtotals</i>	5	0	9	<i>Subtotals</i>	5	0	9
	Total			14	Total			14	Total			14
<i>Sophomore</i>	Language/WAY*	-	-	5	PWR 2/WAY*	-	-	3	PWR 2/WAY*	-	-	3
	CME 103	5	-	-	PHYSICS 41	4	-	-	PHYSICS 43	4	-	-
	ECON 50	-	5	-	CS 106A	-	5	-	CS 103/106B	-	5	-
	MS&E 472	-	-	1	MS&E 140	-	4	-	MS&E 111/180	-	4	-
<i>Subtotals</i>	5	5	6	<i>Subtotals</i>	4	9	3	<i>Subtotals</i>	4	9	3	
	Total			16	Total			16	Total			16
<i>Junior</i>	MS&E 120	5	-	-	MS&E 121	4	-	-	MS&E 125	4	-	-
	MS&E 111/180	-	4	-	TIS/Area	-	3	-	MATH/SCI Elective	3	-	-
	TIS/Area	-	3	-	Area	-	4	-	TIS/Area	-	3	-
	WAY*/Elective	-	-	4	WAY*/Elective	-	-	4	Area	-	4	-
<i>Subtotals</i>	5	7	4	<i>Subtotals</i>	4	7	4	<i>Subtotals</i>	7	7	0	
	Total			16	Total			15	Total			14
<i>Senior</i>	Fundamental Elec	-	3	-	MS&E 108	-	5	-	E25/E40/E80	-	3	-
	Area	-	4	-	Area	-	3	-	Area	-	3	-
	Area	-	3	-	Area/Elective	-	-	3	Electives	-	-	9
	WAY*/Elective	-	-	5	WAY*/Elective	-	-	4				
<i>Subtotals</i>	0	10	5	<i>Subtotals</i>	0	8	7	<i>Subtotals</i>	0	6	9	
	Total			15	Total			15	Total			15

Total Math & Science Units: 44

Total Engineering Units: 68

Total Other Units: 68

Total Units: 180

*MS&E majors automatically satisfy: WAY-AQR (MS&E 120), WAY-FR (CME 100 or MATH 51), WAY-SI (ECON 1, ECON 50, and some TIS); but need to be sure to satisfy: WAY-All (x2), WAY-CE, WAY-ED, WAY-ER (some TiS), and WAY-SMA (x2) (science and some engineering fundamentals).

Management Science & Engineering

Sample Program For Overseas Studies Programs

	<i>Fall</i>				<i>Winter</i>				<i>Spring</i>			
	Math/ Sci.	Engr	Other		Math/ Sci.	Engr	Other		Math/ Sci.	Engr	Other	
<i>Freshman</i>	Class				Class				Class			
	THINK	-	-	4	INTRO SEM	-	-	4	Language/THINK	-	-	5
	CME 100	5	-	-	Language/WAY*	-	-	5	PWR 1	-	-	4
	CS 106A	-	5	-	CS 103/106B	-	5	-	ECON 1	-	-	5
	<i>Subtotals</i>	5	5	4	<i>Subtotals</i>	0	5	9	<i>Subtotals</i>	0	0	14
	Total	14			Total	14			Total	14		
<i>Sophomore</i>	Language/WAY*	-	-	5	PWR 2/WAY*	-	-	4	PWR 2/WAY*	-	-	4
	CME 103	5	-	-	PHYSICS 41	4	-	-	PHYSICS 43	4	-	-
	ECON 50	-	5	-	MS&E 140	-	4	-	MS&E 111/180	-	4	-
	MS&E 472	-	-	1	Area	-	3	-	TIS/Area	-	3	-
	<i>Subtotals</i>	5	5	6	<i>Subtotals</i>	4	7	4	<i>Subtotals</i>	4	7	4
	Total	16			Total	15			Total	15		
<i>Junior</i>	MS&E 120	5	-	-	MS&E 121	4	-	-	WAY*/Elective	-	-	4
	MS&E 111/180	-	4	-	MATH/SCI Elective	3	-	-	OSP Electives	-	-	11
	TIS/Area	-	3	-	TIS/Area	-	4	-				
	WAY*/Elective	-	-	4	Area	-	4	-				
	<i>Subtotals</i>	5	7	4	<i>Subtotals</i>	7	8	0	<i>Subtotals</i>	0	0	15
	Total	16			Total	15			Total	15		
<i>Senior</i>	Fundamental Elec	-	3	-	MS&E 108	-	5	-	MS&E 125	4	-	-
	Area	-	4	-	Area	-	3	-	E25/E40/E80	-	3	-
	Area/Elective	-	3	-	WAY*/Elective	-	-	4	Area	-	3	-
	WAY*/Elective	-	-	5	Elective	-	-	4	Elective	-	-	5
	<i>Subtotals</i>	0	10	5	<i>Subtotals</i>	0	8	8	<i>Subtotals</i>	4	6	5
	Total	15			Total	16			Total	15		

Total Math & Science Units: 34
 Total Engineering Units: 68
 Total Other Units: 78
Total Units: 180

*MS&E majors automatically satisfy: WAY-AQR (MS&E 120), WAY-FR (CME 100 or MATH 51), WAY-SI (ECON 1, ECON 50, and some TiS); but need to be sure to satisfy: WAY-All (x2), WAY-CE, WAY-ED, WAY-ER (some TiS), and WAY-SMA (x2) (science and some engineering fundamentals).

➔ The School of ENGR encourages a quarter abroad. For detail on in-person or online ENGR course options see the Overseas Programs & Engineers page on the UGHB website or Chap 8 of the UGHB.

INSTRUCTIONS FOR DECLARING MAJOR IN MANAGEMENT SCIENCE AND ENGINEERING

We encourage students to declare as early as possible if they are seriously considering the major. The process consists of discussing your plans with the Student Services Manager and meeting prospective advisors until you find a faculty member you want to work with. The MS&E major offers a wide variety of options and students can receive much better guidance once they have declared. Paperwork for the declaration process is available at

<http://www.stanford.edu/dept/MSandE/academics/bsdeclare.html>.

1. Complete the MS&E counseling form, available at
<http://www.stanford.edu/dept/MSandE/academics/bsdeclare.html>.
2. Go into Axess and declare MS&E as your major. Your declaration will be routed to Lori Cottle, Student Services Officer, for approval. Online approval will be given after steps 1-5 are completed.
3. Meet with Lori Cottle in Huang, Suite 114, for a tentative advisor assignment or choose an advisor from the MS&E list of available advisors, available at
<http://www.stanford.edu/dept/MSandE/academics/bsdeclare.html>.
4. Take the counseling form and an unofficial copy of your transcript or Axess grade printout to your new faculty advisor for a declaration advising session.
5. Bring the completed, signed form to Lori Cottle in Huang, Suite 114, who will then approve your online declaration. You will be sent an automatic email from the system after final approval has been given.

Note: The online version of your major (link from the Home or Major Programs page of the UGHB website) is considered the definitive version of 2014-15 requirements; corrections or updates may have been made after the printed and pdf versions were published in August 2014.

★ You must use a program sheet from a year you have been enrolled at Stanford.

Stanford University ♦ School of Engineering
Management Science & Engineering
2014–2015 Program Sheet

Final version of the completed and signed program sheet due to the department no later than one month prior to the last quarter of senior year.

Follow all requirements as stated for the year of the program sheet used.

Name: _____ SU ID #: _____
 Phone: _____ Email: _____
 Today's Date: _____ Month/Yr B.S. expected: _____

Mathematics and Science Requirements (44 units minimum)

Dept	Course	Title	Transfer/AP Approval			Units	Grade
			✓ if Transfer	Initials	Date		
<i>Mathematics (23 units minimum)</i>							
CME	100	or MATH 51 (req'd)				5	
CME	103	Introduction to Matrix Methods (req'd)				5	
MS&E	120	Probabilistic Analysis (req'd)				5	
MS&E	121	Intro to Stochastic Modeling (req'd)				4	
MS&E	125	Introduction to Applied Statistics				4	
<i>Mathematics Unit Total (23 units minimum)</i>							

Science (8 units minimum; see Note 1)

<i>Science Unit Total (8 units minimum)</i>							
<i>Mathematics and Science Unit Total (44 units minimum)</i>							

Technology in Society Requirement (1 course req'd; see note 2)

--	--	--	--	--	--	--	--

NOTES

- * **All courses taken for the major must be taken for a letter grade if that option is offered by the instructor.**
- * This form is available as an Excel file at <http://ughb.stanford.edu/>; you must use a program sheet from a year you were enrolled at Stanford. The printed form must be signed by the advisor and, if required, by the departmental representative. Changes must be initialed in ink by the advisor/dept.
- * Minimum Combined Grade Point Average for all courses in Engineering Fundamentals and Engineering Depth is
- * Transfer and AP credits in Math, Science, Fundamentals, & TIS must be approved by the SoE Dean's office. Transfer credits in Engineering Depth must be approved by the Department. Transfer credit information and petitions are available at <http://ughb.stanford.edu>.
- * All courses listed on this form must only be included under one category. Delete courses not taken.
- (1) Eight units of science required; must include PHYS 41/43, or PHYS 21/22/23/24, or CHEM 31X/33, or CHEM 31B/33. Additional courses in Math and/or Science from SoE-approved lists (or PSYCH 50 or 70) so Math+Science = 44 units minimum.
- (2) MS&E-approved TiS courses: COMM 120W, CS 181, ENGR 130, ENGR 131, MS&E 181, MS&E 193, MS&E 197, STS 1.

program sheet continues on page 2

Management Science and Engineering Program Sheet (continued)

Engineering Fundamentals and Engineering Depth

Dept	Course	Title	Transfer/AP Approval		Units	Grade
			✓ if Transfer	Initials		
<i>Engineering Fundamentals (3 courses required)</i>						
CS	106A	Programming Methodology (req'd)			5	
ENGR		25 or 40/40A/40M/40P or 80 (req'd)				
ENGR		Fund Elective required -- ENGR 62, 70 B or X not allowed (see Note 3)				
<i>Engineering Fundamentals Unit Total</i>						

Engineering Depth (6 courses required; no course may be listed more than once; no double-counting)

		CS 103, or 106B/X (req'd)			5	
ECON	50	Economic Analysis (req'd)			5	
MS&E	108	Senior Project (req'd)			5	
MS&E	111	Intro to Optimization (req'd)			4	
MS&E	140/140X	Accounting (req'd)				
MS&E	180	Organizations (req'd)			4	

Engineering Depth Concentration (8-9 courses required; see note 4)

Circle primary area: F&D O&A OTP						
		Finance & Decision Area Course A				
		Finance & Decision Area Course B				
		Operations & Analytics Area Course A				
		Operations & Analytics Area Course B				
		Organization, Technology, & Policy Course A				
		Organization, Technology, & Policy Course B				
		Primary Area Course C				
		Primary Area Course D				
		Primary Area Course E (if needed)				
<i>Engineering Unit Total</i>						

Program Totals

Mathematics and Science (44 units minimum)

Engineering Fundamentals and Engineering Depth (between 60 and 72 units)

Program Approvals

Advisor/Student Services

Advisor Name: _____ Date: _____

Signature: _____

Departmental

Printed Name: _____ Date: _____

Signature: _____

School of Engineering (No action required -- office use only)

Printed Name: _____ Date: _____

Signature: _____

NOTES (continued from page 1)

- (3) ENGR 62 or 70B or X (same as CS 106B or X) are not allowed as the 3rd fundamental. For a list of alternative approved ENGR Fundamentals, see UGHB, Chapter 3, Fig. 3-4, or Approved Courses lists at
- (4) The "Writing in the Major" requirement will normally be fulfilled through a course taken in the Area or for the Technology in Society requirement.

MATERIALS SCIENCE AND ENGINEERING

Materials Science and Engineering (MSE/MATSCI) is essential to the practice of engineering and technology as all facets of engineering depend critically on the materials utilized for specific applications, ranging from semiconductors for computer chips to polymers for new electronic devices. One important goal of this work involves the development of *processes* for altering the *structure* of materials and thereby controlling their *properties*. This field brings together, in a unified discipline, developments in Physics, Chemistry and Biology that can be, and in fact are, applied to modern materials of technological, engineering, and scientific significance. Materials scientists and engineers utilize a distinctive suite of characterization techniques such as advanced electron microscopes that probe materials structure down to the atomic level. Moreover, our faculty is becoming increasingly involved with nano-technology, energy-related materials and bio-chemical processing.

Students who are interested in both science and its application to important technological problems should consider a career in Materials Science and Engineering. The Undergraduate Program in Materials Science and Engineering provides basic training for those who wish to become materials engineers, and it provides a foundation for more advanced work in the field. Such advanced study enables students to respond effectively to technological change. Able undergraduate Materials Science and Engineering students are encouraged to take at least one year of graduate study in the Stanford Coterminal degree program (see Chapter 7, Other Degree Programs) to extend their coursework and to obtain training in research. Conterminal degree programs are also recommended for any related undergraduate majors. Current research strengths of the department include nano-scale materials, bio-materials, energy and environmental materials, transmission electron microscopy, microelectronic materials science, structure and properties of thin film materials, semiconductors, magnetic materials, photovoltaic and photonic materials, metamaterials, mechanics and mechanical properties of solids, synthesis and applications of nanostructured materials, and computer modeling of materials behavior and processing of metals and alloys.

RESEARCH EXPERIENCE FOR UNDERGRADUATES

It is possible for students to participate in current research projects with the department faculty and their research groups. The department plans to continue its summer research program through a grant from the School of Engineering/Vice Provost for Undergraduate Education in the

2014-2015 year. Information about individual programs may be obtained from the MSE department home page. Arrangements may also be made by direct consultation with the relevant professor.

Students who wish to receive further information about the programs in Materials Science and Engineering should contact:

Professor Bob Sinclair (**bobsinc@stanford.edu**) or
Kevin Gribble, Student Services Specialist (**kgribble@stanford.edu**)
Department of Materials Science and Engineering (MSE)
496 Lomita Mall, William F. Durand Building
Stanford University
Stanford, CA 94305-4034

REQUIREMENTS FOR UNDERGRADUATES IN MATERIALS SCIENCE AND ENGINEERING

School of Engineering (SoE) Requirements

This set of requirements is monitored by the SoE and is required for all engineering majors. Petitions to transfer credit, deviate from the requirements, or approve appropriate AP credit must be made to the SoE Dean's Office of Student Affairs in 135 Huang (details in Chapter 4 or at ughb.stanford.edu).

Mathematics and Science (40 units combined, minimum)

MATH (20 UNITS MINIMUM)

COURSE	Title	Units
One of the following courses:		5
MATH 51	Linear Algebra and Differential Calculus of Several Variables	5
or CME 100/ENGR 154	Vector Calculus for Engineering	5
One of the following courses:		5
MATH 52	Integral Calculus of Several Variables	5
or CME 104/ENGR 155B	Linear Algebra and Partial Differential Equations for Engineers	5
One of the following courses:		5
MATH 53	Ordinary Differential Equations with Linear Algebra	5
or CME 102/ENGR 155A	Ordinary Differential Equations for Engineers	5
One additional course.¹		5

SCIENCE (20 UNITS MINIMUM)²

Course	Units
A full year of physics or chemistry	15
One quarter of study in the other subject.	5

Notes:

¹ See Chapter 3, Fig. 3-1 for a list of SoE approved Mathematics & Statistics courses.

² See Chapter 3, Fig. 3-2 for a list of SoE approved Science courses. AP credit is also acceptable with SoE Dean's Office approval.

Technology in Society (One course; 3-5 units)

See Chapter 3, Fig. 3-4 for the list of SoE approved courses that fulfill the TIS requirement.

School of Engineering (SoE) Fundamentals

(Three courses minimum: one of the ENGR 50 options and two electives)

Course	Title	Units
One of the following courses³:		
ENGR 50	Introduction to Materials Science – Nanotechnology ³	4
ENGR 50E	Introduction to Materials Science – Energy ³	4
ENGR 50M	Introduction to Materials Science – Biomaterials ³	4

Two of the following courses (6-10 units):		
ENGR 14 <i>OR</i> ENGR 15	Introduction to Solid Mechanics <i>OR</i> Dynamics	4 4
ENGR 20	Introduction to Chemical Engineering	3
ENGR 25B <i>OR</i> ENGR 25E	Biotechnology <i>OR</i> Energy: Chemical Transformations for Prod., Storage, & Use	3 3
ENGR 30	Engineering Thermodynamics	3
ENGR 40 <i>OR</i> ENGR 40M <i>OR</i> ENGR 40P	Introductory Electronics <i>OR</i> An Intro to Making: What is EE <i>OR</i> Physics of EE	5 5 5
ENGR 62	Introduction to Optimization	4
ENGR 70A <i>OR</i> ENGR 70B <i>OR</i> ENGR 70X	Programming Methodology (same as CS 106A) <i>OR</i> Programming Abstractions (same as CS 106B) <i>OR</i> Programming Abstractions (accelerated) (same as CS 106X)	5 5 5
ENGR 80	Introduction to Bioengineering	4
ENGR 90	Environmental Science and Technology	3

Total School of Engineering Units

53-59

Departmental Requirements: MSE Fundamentals, Depth, & Focus Area Options

These requirements are specified and monitored by the department of Materials Science and Engineering. Petitions for exceptions must be made to the department. The MATSCI 150 series represents a stand-alone curriculum, which is recommended for undergraduates. The 190 series courses are advanced level courses, which may be substituted for the equivalent 150 series courses or can be taken as follow-on courses.

MSE Fundamentals (24 UNITS)

Course	Title	Units
ALL of the following courses:		16
MATSCI 153	Nanostructure and Characterization	4
MATSCI 154 ⁴	Thermodynamic Evaluation of Green Energy Technologies ⁴	4
MATSCI 155	Nanomaterials Synthesis	4
MATSCI 157	Quantum Mechanics of Nanoscale Materials	4
Two of the following courses:		8
<i>Undergraduate Core Courses</i>		
ENGR 50	Introduction to Materials Science – Nanotechnology ³	4
ENGR 50E	Introduction to Materials Science – Energy ³	4
ENGR 50M	Introduction to Materials Science – Biomaterials ³	4
MATSCI 151	Microstructure and Mechanical Properties	4
MATSCI 152	Electronic Materials Engineering	4
MATSCI 156	Solar Cells, Fuel Cells, & Batteries: Materials for the Energy Solution	4
Advanced Level Courses:		
MATSCI 190	Organic and Biological Materials	4
MATSCI 192	Materials Chemistry	4
MATSCI 193	Atomic Arrangements in Solids	4
MATSCI 194	Thermodynamics and Phase Equilibria	4

MATSCI 195	Waves and Diffraction in Solids	4
MATSCI 196	Imperfections in Crystalline Solids	4
MATSCI 197	Rate Processes in Materials	4
MATSCI 198	Mechanical Properties of Materials	4
MATSCI 199	Electronic and Optical Properties of Solids	4

Notes:

³ Students may choose to count a second ENGR 50/50E/50M course (one must be taken as a SoE fundamental requirement) as part of the MSE fundamental requirements.

⁴ ENGR 30 can be substituted for MATSCI 154, but cannot be used for both the SoE fundamentals and MSE fundamentals requirements. No petition required for this substitution as long as overall units (including SoE Funds and all MSE requirements) total 60 or more units. If E 30 is substituted for MATSCI 154, MSE Fundamentals may contain only 23 units.

MSE Depth (16 UNITS FROM FOUR OF THE FOLLOWING LABORATORY-BASED COURSES)

Course	Title	Units
One of the following courses:		4
MATSCI 161	Nanocharacterization Laboratory (satisfies WIM requirement)	4
MATSCI 164	Electronic & Photonic Materials and Devices Lab (satisfies WIM req't)	4
Three of the following courses:		12
MATSCI 160	Nanomaterials Laboratory	4
MATSCI 162	X-Ray Diffraction Laboratory	4
MATSCI 163	Mechanical Behavior Laboratory	4
MATSCI 165	Nanoscale Materials Physics Computation Laboratory	4

Focus Area Options (10 units minimum from one of the Ten areas)⁵

BIOENGINEERING

Course	Title	Units
BIOE 220	Imaging Anatomy	3
BIOE 281	Biomechanics of Movement	3
BIOE 284A	Cardiovascular Bioengineering	3
BIOE 284B	Cardiovascular Bioengineering	3
BIOE 333	Interfacial Phenomena and Bionanotechnology	3
BIOE 381	Orthopaedic Bioengineering	3
MATSCI 190	Organic and Biological Materials	4
MATSCI 380	Nano-Biotechnology	3
MATSCI 381	Biomaterials in Regenerative Medicine	3
MATSCI 382	Bio-Chips, Imaging, and Nanomedicine	3

CHEMICAL ENGINEERING

Course	Title	Units
CHEM 171	Physical Chemistry	3
CHEMENG 130	Separation Processes	3
CHEMENG 140	Microelectronics Processing Technology	3
CHEMENG 150	Biochemical Engineering	3
CHEMENG 160	Polymer Science and Engineering	3

CHEMISTRY

Course	Title	Units
CHEM 151	Inorganic Chemistry I	3
CHEM 153	Inorganic Chemistry II	3
CHEM 171	Physical Chemistry I	3
CHEM 173	Physical Chemistry II	3
CHEM 175	Physical Chemistry III	3
CHEM 181	Biochemistry I	3
CHEM 183	Biochemistry II	3
CHEM 185	Biochemistry III	3

ELECTRONICS AND PHOTONICS

Course	Title	Units
EE 101A	Circuits I	4
EE 101B	Circuits II	4
EE 102A	Signal Processing and Linear Systems I	4
EE 102B	Signal Processing and Linear Systems II	4
EE 116	Semiconductor Device Physics	3
EE 134	Introduction to Photonics	4
EE 136	Introduction to Nanophotonics and Nanostructures	3
EE 141	Engineering Electromagnetics	4
MATSCI 343	Organic Semiconductors for Electronics and Photonics	3

ENERGY TECHNOLOGY

Course	Title	Units
EE 293B	Fundamentals of Energy Processes	3
MATSCI 156	Solar Cells, Fuel Cells, and Batteries: Materials for the Energy Solution	3
MATSCI 302	Solar Cells	3
MATSCI 303	Principles, Materials, and Devices of Batteries	3
ME 260	Fuel Cell Science Technology	3

MATERIALS CHARACTERIZATION TECHNIQUES

Course	Title	Units
MATSCI 320	Nanocharacterization of Materials	3
MATSCI 321	Transmission Electron Microscopy	3
MATSCI 322	Transmission Electron Microscopy Laboratory	3
MATSCI 323	Thin Film and Interface Microanalysis	3
MATSCI 326	X-Ray Science and Techniques	3

MECHANICAL BEHAVIOR AND DESIGN

Course	Title	Units
AA 240A	Analysis of Structures	3
AA 240B	Analysis of Structures	3
AA 256	Mechanics of Composites	3
MATSCI 198	Mechanical Properties of Materials	4
MATSCI 358	Fracture and Fatigue of Engineering Materials	3
ME 80 <i>OR</i>	Mechanics of Materials (ME) <i>OR</i>	4
CEE 101A	Mechanics of Materials (CEE)	4
ME 203	Design and Manufacturing	4
ME 294	Medical Device Design	3

NANOSCIENCE

Course	Title	Units
BIOE 333	Interfacial Phenomena and Bionanotechnology	3
EE 136	Introduction to Nanophotonics and Nanostructures	3
ENGR 240	Introduction to Micro and Nano Electromechanical Systems	3
MATSCI 316	Nanoscale Science, Engineering and Technology	3
MATSCI 320	Nano-characterization of Materials	3
MATSCI 346	Nanophotonics	3
MATSCI 347	Introduction to Magnetism and Magnetic Nanostructures	3
MATSCI 380	Nano-Biotechnology	3

PHYSICS

Course	Title	Units
PHYSICS 70	Foundations of Modern Physics	4
PHYSICS 110	Intermediate Mechanics	4
PHYSICS 120	Intermediate Electricity and Magnetism I	4
PHYSICS 121	Intermediate Electricity and Magnetism II	4
PHYSICS 130	Quantum Mechanics I	4
PHYSICS 131	Quantum Mechanics II	4
PHYSICS 134	Advanced Topics in Quantum Mechanics	4
PHYSICS 170	Thermodynamics, Kinetic Theory & Statistical Mechanics I	4
PHYSICS 171	Thermodynamics, Kinetic Theory & Statistical Mechanics II	4
PHYSICS 172	Solid State Physics	3

SELF-DEFINED FOCUS (10 UNITS MINIMUM)

Student may petition for approval of a self-defined option containing a minimum of 10 units that comprise a cohesive program of study.

Notes: ⁵ If the focus area option contains only 9 units, but the combined unit total is at 60 or more, it will be allowed and no petition is necessary

MSE MAJOR UNIT REQUIREMENT:

Combined units from the following group of courses **must total a minimum of 60 units**. Units cannot be counted under more than one category.

SoE Fundamentals 10-14 units

MSE Fundamentals 24 units

MSE Depth 16 units

Focus Area Options⁴ 10 units

By adding these 60 units to the 40 required math and science units and the minimum of 3 units for the Technology in Society course, your Materials Science undergraduate major program will require a minimum of 103 units of the 180 you need to graduate. Your advanced placement math and science units from high school may count toward the 40 units of basic math and science, thereby allowing you more electives during your Stanford career.

Materials Science and Engineering

Typical Sequence of Courses

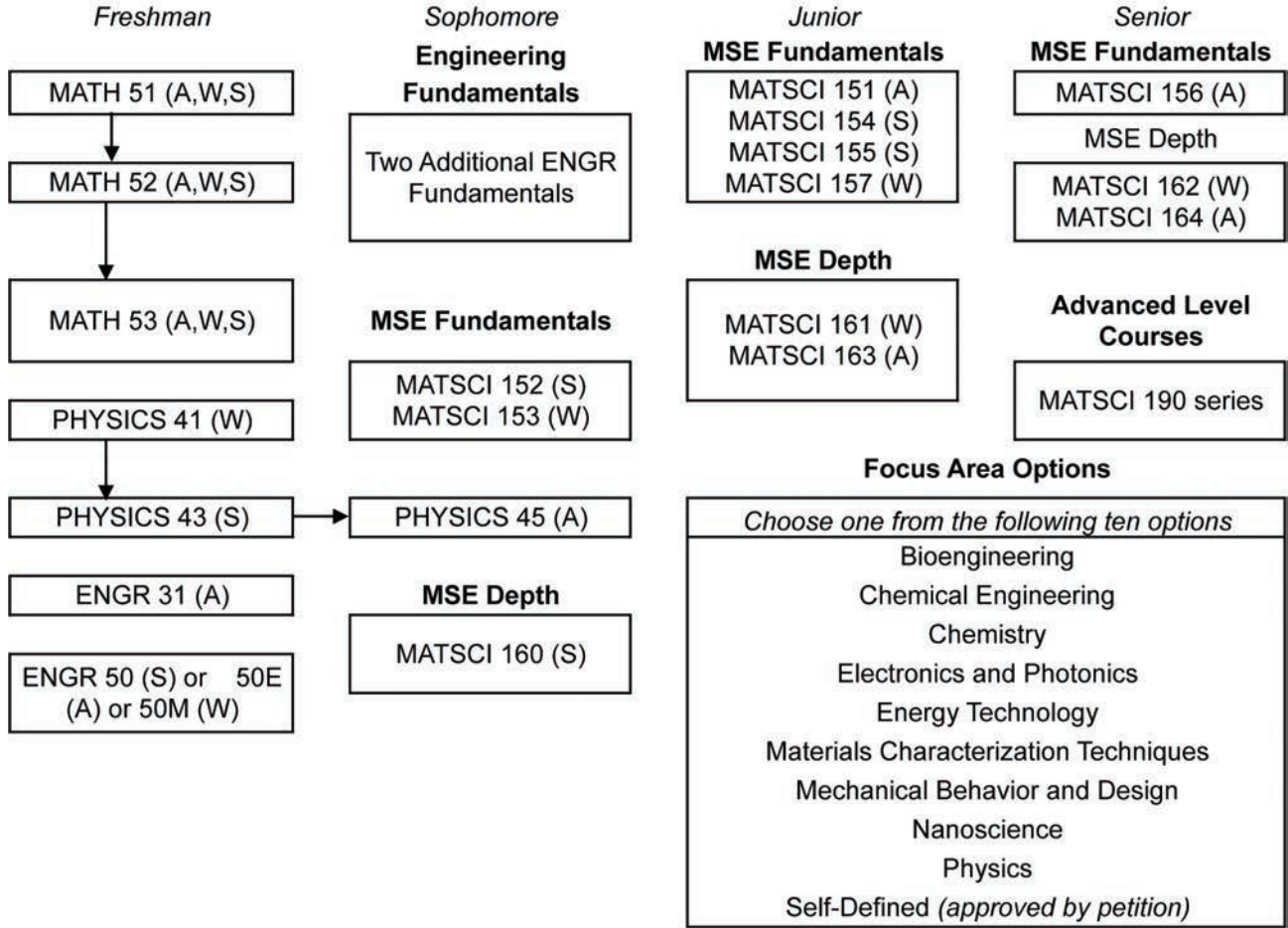

Materials Science and Engineering

Sample 4-Year Plan

	<i>Fall</i>				<i>Winter</i>				<i>Spring</i>			
	Class	Math/ Sci.	Engr.	Other	Class	Math/ Sci.	Engr.	Other	Class	Math/ Sci.	Engr.	Other
<i>Freshman</i>	MATH 51	5	-	-	MATH 52	5	-	-	MATH 53	5	-	-
	IntroSeminar	-	-	4	THINK	-	-	4	PWR 1	-	-	4
	ENGR 31	4	-	-	CHEM 33	5	-	-	PHYSICS 43	4	-	-
					PHYSICS 41	4	-	-				
	<i>Subtotals</i>	9	0	4	<i>Subtotals</i>	14	0	4	<i>Subtotals</i>	9	0	4
	Total		13	Total		18	Total		13			
<i>Sophomore</i>	ENGR 50E	-	4	-	MATSCI 153	-	4	-	MATSCI 152	-	4	-
	PHYSICS 45	4	-	-	Engr. Fund	-	5	-	MATSCI 160	-	4	-
	Engr. Fund	-	3	-	Soph. Seminar	-	-	3	PWR 2	-	-	4
	Language	-	-	5	Language	-	-	5	Language	-	-	5
	<i>Subtotals</i>	4	7	5	<i>Subtotals</i>	0	9	8	<i>Subtotals</i>	0	8	9
	Total		16	Total		17	Total		17			
<i>Junior</i>	MATSCI 151	-	4	-	MATSCI 157	-	4	-	MATSCI 155	-	4	-
	WAYS	-	-	3	MATSCI 161	-	3	-	Option Sequence	-	4	-
	MATSCI 163	-	4	-	WAYS	-	-	4	MATSCI 154	-	4	-
	WAYS	-	-	3	WAYS	-	-	3	WAYS	-	-	3
	<i>Subtotals</i>	0	8	6	<i>Subtotals</i>	0	7	7	<i>Subtotals</i>	0	12	3
	Total		14	Total		14	Total		15			
<i>Senior</i>	MATSCI 156	-	4	-	MATSCI 162	-	4	-	Option Sequence		4	-
	MATSCI 164	-	4	-	Tech in Society	-	4	-	190s series	-	4	-
	Option Sequence	-	3	-	WAYS	-	-	3	WAYS	-	-	4
	<i>Subtotals</i>	0	11	0	<i>Subtotals</i>	0	8	3	<i>Subtotals</i>	0	8	4
	Total		11	Total		11	Total		12			

AP Math Units: 10
 UG Math & Science Units: 36
 Total Engineering Units: 78
 Total Other Units: 57
Total Units: 181

→ The School of ENGR encourages a quarter abroad. For detail on in-person or online ENGR course options see the Overseas Programs & Engineers page on the UGHB website or Chap 8 of the UGHB.

INSTRUCTIONS FOR DECLARING MAJOR IN MATERIALS SCIENCE AND ENGINEERING

- Enter your major declaration for Materials Science & Engineering in Axess.¹
- Notify the department of your major declaration by sending an email to matsciengr@stanford.edu. You may submit your advisor preference at this time. An advisor will be assigned to you if you have no preference.
- Download and complete the MSE Program Sheet from the School of Engineering website at <http://ughb.stanford.edu/>. When completing the Program Sheet, include courses you plan to take as well as those you have already taken. Print your unofficial Stanford transcript from Axess and attach to your Program Sheet.
- Meet with your major advisor to review the Program Sheet; have your advisor sign your Program Sheet to indicate your program plan is approved.²
- Procedures for requesting transfer/AP credits and program deviations are described in detail in Chapter 4 Policies and Procedures in the UGHB. The relevant forms may be downloaded from <http://ughb.stanford.edu> under the Petitions link. SoE petitions must be approved by SoE Dean's Office of Student Affairs in Huang 135.
- Return completed Program Sheet to Kevin Gribble in Durand Building 111A.

Notes:

¹ Stanford requires the declaration of a major by the end of sophomore year. The department will accept later declarations from students who change majors.

² If your program proposal changes during the course of your program, submit revisions after consulting with your advisor. Initial Program Sheet should be submitted during the same quarter of your major declaration or no later than the first quarter of your junior year. A final version is due one quarter prior to the graduating term. Student athletes must complete a Program Sheet at the time of major declaration for verification of NCAA-related major courses as required by Stanford.

Note: The online version of your major (link from the Home or Major Programs page of the UGHB website) is considered the definitive version of 2014-15 requirements; corrections or updates may have been made after the printed and pdf versions were published in August 2014.

★ You must use a program sheet from a year you have been enrolled at Stanford.

Materials Science and Engineering Program Sheet (continued)

Materials Science and Engineering Depth (50 units minimum)

Dept	Course	Title	Transfer/AP Approval			Units	Grade
			✓ if Transfer	Initials	Date		
<i>MSE Fundamentals (choose six lecture courses for 24 units)</i>							
MATSCI	153	Nanostructure and Characterization (required)				4	
MATSCI	154	Thermodynamic Evaluation of Green Energy Technologies (req'd)				4	
MATSCI	155	Nanomaterials Synthesis (required)				4	
MATSCI	157	Quantum Mechanics of Nanoscale Materials (required)				4	
<i>Materials Science Fundamentals Unit Total (24 units)</i>							

MSE Depth (choose four laboratory courses for 16 units)

MATSCI	161 or 164	Satisfies Writing in the Major (WIM) requirement				4	
<i>Engineering Depth Unit Total (16 units)</i>							

Focus Option Area (10 units minimum; select from one of the ten Options Areas. See note 3)

Option area is:

<i>Option Area Unit Total (10 units minimum)</i>							
<i>Materials Science Engineering Depth Total (50 units minimum)</i>							

Program Totals

Mathematics and Science (40 units minimum)
TIS and Engineering Fundamentals (13 units minimum)
Materials Science and Engineering Depth (50 units minimum)

Program Approvals

Advisor

Printed Name: _____

Date: _____

Signature: _____

Departmental

Printed Name: _____

Date: _____

Signature: _____

School of Engineering (No action required -- office use only)

Printed Name: _____

Date: _____

Signature: _____

NOTES

- (3) If the focus area option contains only 9 units but the combined units total from Engr. Fundamentals and MatSci Depth is 60 or more, it will be allowed and no petition is necessary.
- (4) If ENGR 30 is substituted for MATSCI 154, the MSE Fundamentals area may contain only 23 units. As long as the overall ENGR fundamentals and MSE depth requirements are 60 or more units, no petition is required.

MECHANICAL ENGINEERING

— ABET ACCREDITATION CRITERIA APPLY —

Mechanical engineers create products, machines, and technological systems for the benefit of society. Building on a foundation of physical science, mathematics, and an understanding of societal needs and responsibilities, they develop solutions across a wide range of fields from energy to medical devices, manufacturing to transportation, consumer products to environmental compatibility. The undergraduate program in Mechanical Engineering at Stanford exposes each student to intellectual and practical experiences that form a basis from which to develop solutions, and provides an environment that allows for the accumulation of knowledge and self-discovery so as to extend the domain within which solutions can be formulated. Graduates of the program have many professional options and opportunities, from entry-level work as mechanical engineers to graduate studies in either an engineering discipline or in another field where a broad engineering background is useful. Regardless of the ultimate career choice, graduates leave the program with a solid grounding in the principals and practice of mechanical engineering, equipped to embark upon a lifetime of learning, while employing new concepts, technologies and methodologies.

RESEARCH EXPERIENCE FOR UNDERGRADUATES

The Mechanical Engineering department offers a Summer Undergraduate Research Institute (SURI) (http://me.stanford.edu/current_students/ug_research.html). The 2015 program will include student research training in team settings (e.g., students working together on larger projects directed by staff and faculty), and in individually-directed research settings (e.g., the student will work closely with a faculty advisor or senior graduate student).

The program is open only to Stanford undergraduate students. Students do not necessarily have to be declared ME majors. There is no formal application for participation in the ME SURI. Students who are interested in participating in the ME program should seek out research opportunities directly with ME faculty and secure a commitment/position for the summer by the end of May (2015). Sponsoring faculty will contact the program administrator once a commitment to a student is made. Students can also contact the program administrator, Perry Thoorsell at perryt@stanford.edu directly for more information.

PROFESSIONAL LICENSING

Professional licensing is an important aspect of professional responsibility. Although civil engineers may find professional registration more important in securing employment, mechanical engineers should seriously consider pursuing licensing as well. A professional license can be important if you work as a consultant or at a small start-up. An engineer working for a start-up or small technical company must fill a much wider spectrum of professional roles than would be the case working for a larger company. Those roles would typically include certifying drawings and other technical materials that require a license as a professional engineer.

In addition to certifying the accuracy of technical materials produced by yourself or your company, a professional license is important if you have to testify as an expert witness or perform other functions related to the legal system. In many states, including California, you cannot legally use the title “engineer” unless you are a licensed Professional Engineer. In fact the California law requires that “...only a person appropriately licensed with the Board may practice or offer to practice mechanical engineering.”

To attain a professional license you must take the Fundamentals of Engineering (F.E.) examination administered by the California Board for Professional Engineers and Land Surveyors (<http://www.dca.ca.gov/pels/>) or equivalent body in the state in which you plan to practice. The examination may be taken at any time, but most people find it easier to pass when completing their undergraduate work and more difficult later on. After passing the F.E. examination you will be eligible to receive an Engineer in Training (E.I.T.) certificate. At least two more years of practical experience and a further examination are required for a full license.

OBJECTIVES AND OUTCOMES FOR MECHANICAL ENGINEERING

Program Educational Objectives:

1. Graduates of our program will have the scientific and technical background for successful careers in diverse organizations.
2. Graduates of our program will be leaders, and effective communicators, both in the profession and in the community.
3. Graduates of our program will be motivated and equipped to successfully pursue postgraduate study whether in engineering, or in other fields.
4. Graduates of our program will have a professional and ethical approach to their careers with a strong awareness of the social contexts in which they work.

Student Outcomes:

Technical Skills:

1. An ability to apply knowledge of science, engineering and mathematics including multivariate calculus and differential equations
2. An ability to design and conduct experiments, as well as to analyze and interpret data
3. An ability to design a system, component, or process to meet desired needs within realistic constraints
4. An ability to identify, formulate, and solve engineering problems
5. An ability to use the techniques, skills, and modern engineering tools necessary for engineering practice
6. Experience in both thermal and mechanical systems including the design and realization of either type of system.

Professional Skills:

1. An ability to function on multidisciplinary teams
2. An understanding of professional and ethical responsibility
3. An ability to communicate effectively the broad education necessary to understand the impact of engineering solutions in a global, economic, environmental, and societal context
4. A recognition of the need for, and an ability to engage in life-long learning
5. A knowledge of contemporary issues.

REQUIREMENTS

Mathematics and Science

The program requires a minimum 45 units of Math and Science combined. A minimum of 24 units of mathematics are required, which **must** include both a course in Differential Equations (e.g., CME102/ENGR 155A or MATH 53 is required) and a course in calculus-based statistics (CME 106, STATS 110 or STATS 116). A minimum of 20 units of science are required, which must include both chemistry and physics, with a depth in at least one (a **depth** is defined as three courses). Although CHEM 31X is equivalent to taking CHEM 31A and CHEM 31B, we recommend ME students take CHEM 31X or ENGR 31. Students who choose to take

CHEM31A/B should note that these two courses combined are considered one quarter worth of chemistry. See the Mathematics and Science Requirement section of this handbook for details.

Physics Depth: Students without advanced placement in Physics take PHYSICS 41, 43, & 45. Students with advanced placement should refer to the chart on **page 24 of this Handbook for the 2014-15 AP placement chart**. Note that only AP Physics C, not AP Physics B, will place a student out of a 40-series class requirement.

Chemistry Depth: Students opting to take chemistry as their science depth must also take one quarter of physics from the 40 (calculus-based) series. Courses from the Physics 20 series are not allowed.

Engineering Fundamentals: Three courses required (Fr, So, Jr)

Course	Title	Units	Qtr	Year
1) ENGR 40	Introductory Electronics (req'd)	5	AS	So,Jr
2) ENGR 70A	Programming Methodology (req'd)	5	AWSSu	Fr,So
3) Fundamental Elective	See Figure 3-4 in Chapter 3 for list of approved alternatives; CS 106B or X not allowed;			

*ME fundamentals elective may not be a course counted towards other requirements. Students may opt to use ENGR 14, 15, or 30 from the required depth courses as the third fundamental class. However, total units for Engineering Topics (Fundamentals + Depth) must be a minimum of 68 units. Additional options courses may be required to meet unit requirements.

Technology in Society (TIS): One course required from approved list in Chap 3, Fig. 3-3

Mechanical Engineering Depth Requirements (55-56 units from the following list)

Note: A minimum of 68 units consisting of a combination of ME Depth and Engineering Fundamentals courses must be taken in order to satisfy ABET and SoE graduation requirements.

Course	Title	Units	Qtr	Year
ENGR 14	Introduction to Solid Mechanics	4	AWS	Fr,So
ENGR 15	Dynamics	4	AS	So, Jr
ENGR 30	Engineering Thermodynamics	3	AWS	So,Jr
ME 70	Introductory Fluids Engineering	4	WS	So,Jr
ME 80	Mechanics of Materials	4	AS	Jr,Sr
ME 101	Visual Thinking	4	AWS	So,Jr
ME 103D	Engineering Drawing	1	AW	So,Jr
ME 112*	Mechanical Engineering Design	4	W	Jr,Sr
ME 113	Mechanical Engineering Design	4	S	Jr,Sr
ME 131A*/B	Heat Transfer & Fluid Mechanics	9	AW	Jr,Sr
ME 140*	Advanced Thermal Systems	5	S	Jr,Sr
ME 161	Dynamic Systems	4	A	
ME 203	Manufacturing & Design	4	AW	Jr,Sr
ME Electives (6 units minimum):				
Select two or three courses from the following list:				
AA 283, ENGR 105, ENGR 110, ENGR 240, ME 210, ME 219, ME 220, ME 227, ME 250, ME 257, ME 260,				

* ME 112, ME131A and ME140 combined fulfill the “Writing in the Major” requirement.

NOTES:

1. The Undergraduate Curriculum Committee of the Department of Mechanical Engineering Student Services Office must approve any deviation from the Engineering Depth (ME) requirement. Such petitions must be prepared on the School of Engineering petition forms (see the forms section at ughb.stanford.edu or in this handbook), approved by the advisor, and submitted by **the third week of the quarter before the expected graduation quarter**. For example, for a June graduation, a student must submit the petition by the third week of Winter quarter.
2. It is recommended that students review prerequisites for all courses before planning their course sequence
3. Petitions to deviate from School of Engineering requirements (i.e., math, science, Engineering Fundamentals, TIS) must be approved by the Dean’s office in 135 Huang Engineering Center.

Mechanical Engineering

Typical Sequence of Courses

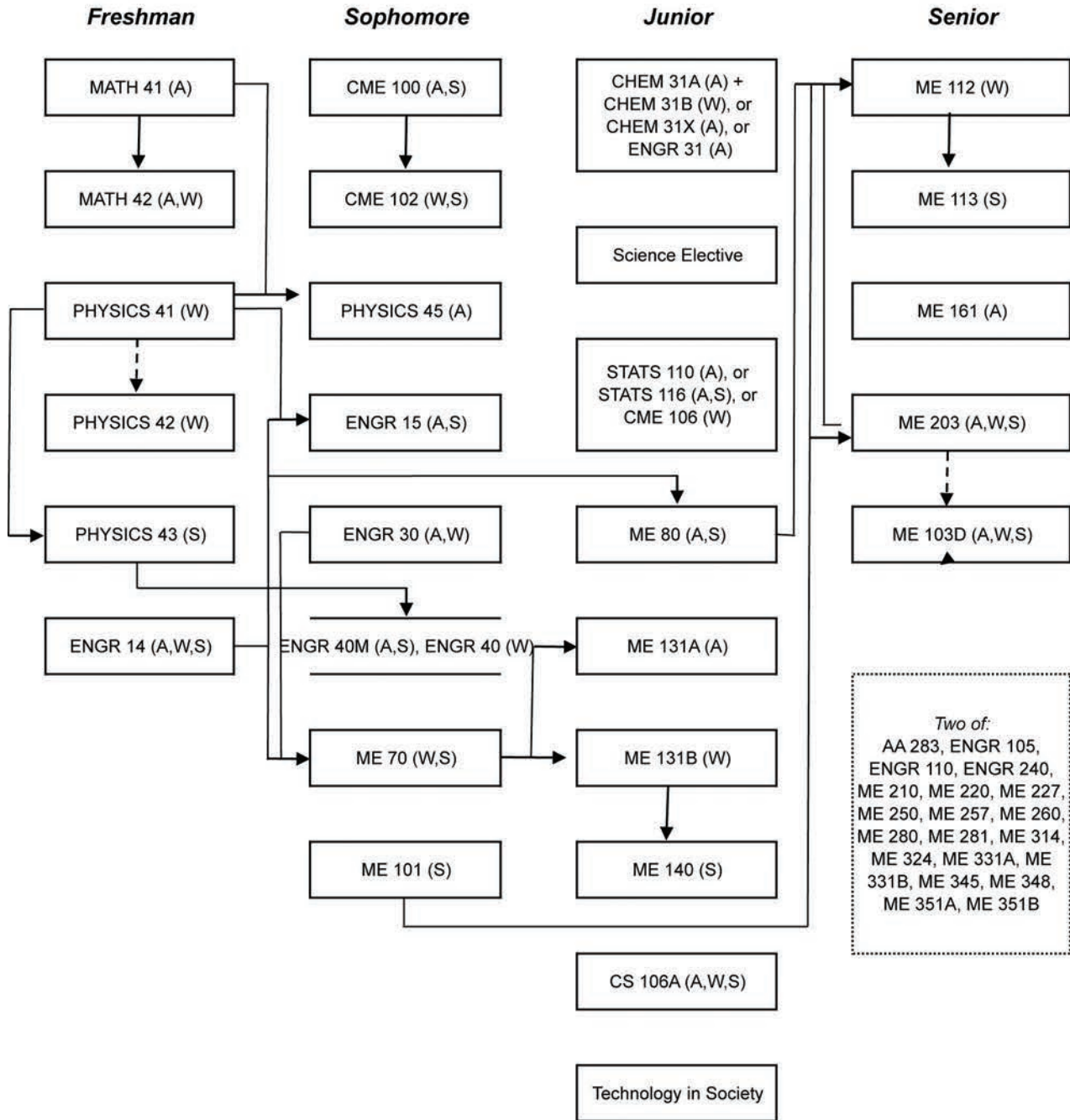

- * Solid arrows represent direct prerequisites
- * Dashed lines represent co-requisites.
- * Dashed-line boxes enclose course options.

Mechanical Engineering

Plan A Math: CME Series, starting with MATH 41
 (Recommended) Science: One Year PHYSICS, One Quarter CHEM (31X)
 Engineering Start: Typical
 Quarter Abroad: None

	<i>Fall</i>				<i>Winter</i>				<i>Spring</i>			
	Class	M&S	Engr	Other	Class	M&S	Engr	Other	Class	M&S	Engr	Other
<i>Freshman</i>	THINK/WAYS ¹	-	-	4	Intro Seminar	-	-	4	Intro Seminar	-	-	4
	WAYS ¹	-	-	4	MATH 42	5	-	-	ENGR 14	-	4	-
	MATH 41	5	-	-	PHYSICS 41	4	-	-	PHYSICS 43	4	-	-
					PHYSICS 42	1	-	-				
	<i>Subtotals</i>	5	0	8	<i>Subtotals</i>	10	0	4	<i>Subtotals</i>	4	4	4
	Total			13	Total			14	Total			12
<i>Sophomore</i>	WAYS ¹	-	-	4	ME 101 ¹	-	4	-	ENGR 40 ¹	-	5	-
	Language	-	-	5	Language	-	-	5	Language	-	-	5
	PHYSICS 45	4	-	-	ENGR 30	-	3	-	ME 70	-	4	-
	CME 100	5	-	-	CME 102	5	-	-	ENGR 15	-	4	-
	<i>Subtotals</i>	9	0	9	<i>Subtotals</i>	5	7	5	<i>Subtotals</i>	0	13	5
	Total			18	Total			17	Total			18
<i>Junior</i>	ME 131A ⁴	-	5	-	ME 131B	-	4	-	ME 140 ⁴	-	5	-
	ENGR 31/CHEM 31X	4	-	-	Sci Elective ³	4	-	-	ME 80	-	4	-
	Statistics ^{1,2}	4	-	-	CS 106A ¹	-	5	-	TIS Course ¹	-	-	4
	UnrestrElective	-	-	3	UnrestrElective	-	-	4	WAYS ¹	-	-	4
	<i>Subtotals</i>	8	5	3	<i>Subtotals</i>	4	9	4	<i>Subtotals</i>	0	9	8
	Total			16	Total			17	Total			17
<i>Senior</i>	ME 203	-	4	-	ME 112 ⁴	-	4	-	ME 113	-	4	-
	ME 103D	-	1	-	ME Depth Elect	-	3	-	ME Depth Elective	-	3	-
	ME 161	-	4	-	WAYS ¹	-	-	3	WAYS ¹	-	-	5
	WAYS ¹	-	-	4	UnrestrElective	-	-	3	WAYS ¹	-	-	3
	<i>Subtotals</i>	0	9	4	<i>Subtotals</i>	0	7	6	<i>Subtotals</i>	0	7	8
	Total			13	Total			13	Total			15

Total Math & Science Units 45
 Total Engineering Units 70
 Total Other Units 68
Total Units 183

Notes:

- These courses can be rearranged to accommodate schedule
- Statistics course availability varies: STAT 110 is offered in the Autumn; CME106 is offered in the Winter, STAT 116 is offered Autumn and Spring, but requires MATH 52 as a prerequisite.
- After PHYSICS 41/43/45 plus ENGR 31/CHEM 31X, 4-5 more units of science is needed. Any number of these units may come from laboratory courses that accompany PHYSICS 41/43/45. Note: Science and Math units combined must equal a minimum of 45 units.
- ME112, ME131A and ME140 combined fulfill the WIM requirement

Mechanical Engineering

Plan D Math: MATH Series, starting with MATH 41
 Science: One Year PHYSICS, One Quarter CHEM (31A + 31B)
 Engineering Start: Typical
 Quarter Abroad: None

	<i>Fall</i>				<i>Winter</i>				<i>Spring</i>			
	Class	M&S	Engr	Other	Class	M&S	Engr	Other	Class	M&S	Engr	Other
<i>Freshman</i>	THINK/WAYS ¹	-	-	4	Intro Seminar	-	-	4	ENGR 14	-	4	-
	WAYS ¹	-	-	4	MATH 42	5	-	-	MATH 51	5	-	-
	MATH 41	5	-	-	PHYSICS 41	4	-	-	PHYSICS 43	4	-	-
					PHYSICS 42	1	-	-				
	<i>Subtotals</i>	5	0	8	<i>Subtotals</i>	10	0	4	<i>Subtotals</i>	9	4	0
	Total			13	Total			14	Total			13
<i>Sophomore</i>	WAYS ¹	-	-	4	ME 101 ¹	-	4	-	ENGR 40 ¹	-	5	-
	Language	-	-	5	Language	-	-	5	Language	-	-	5
	PHYSICS 45	4	-	-	ENGR 30	-	3	-	ME 70	-	4	-
	Elective	-	-	3	MATH 53	5	-	-	ENGR 15	-	4	-
	<i>Subtotals</i>	4	0	12	<i>Subtotals</i>	5	7	5	<i>Subtotals</i>	0	13	5
	Total			16	Total			17	Total			18
<i>Junior</i>	ME 131A ³	-	5	-	ME 131B	-	4	-	ME 140 ³	-	5	-
	CHEM 31A	5	-	-	CHEM 31B	5	-	-	ME 80	-	4	-
	Statistics ^{1,2}	4	-	-	CS 106A ¹	-	5	-	TIS Course ¹	-	-	4
	UnrestrElective	-	-	3	UnrestrElective	-	-	4	WAYS ¹	-	-	4
	<i>Subtotals</i>	9	5	3	<i>Subtotals</i>	5	9	4	<i>Subtotals</i>	0	9	8
	Total			17	Total			18	Total			17
<i>Senior</i>	ME 203	-	4	-	ME 112 ³	-	4	-	ME 113	-	4	-
	ME 103D	-	1	-	ME Depth Elect	-	3	-	ME Depth Elect	-	3	-
	WAYS ¹	-	-	4	WAYS ¹	-	-	3	WAYS ¹	-	-	5
	ME 161	-	4	-	UnrestrElective	-	-	3	UnrestrElective	-	-	3
	<i>Subtotals</i>	0	9	4	<i>Subtotals</i>	0	7	6	<i>Subtotals</i>	0	7	8
	Total			13	Total			13	Total			15

Total Math & Science Units 47
 Total Engineering Units 70
 Total Other Units 67
Total Units 184

Notes:

- ¹ These courses can be rearranged to accommodate schedule
- ² Statistics course availability varies: STAT 110 is offered in the Autumn; CME106 is offered in the Winter, STAT 116 is offered Autumn and Spring, but requires MATH 52 as a prerequisite.
- ³ ME112, ME131A and ME140 combined fulfill the WIM requirement

Mechanical Engineering

Plan E Math: CME Series, starting with MATH 41
 Science: One Year PHYSICS, One Quarter CHEM (31X)
 Engineering Start: Late
 Quarter Abroad: None

	Fall			Winter			Spring					
	Class	M&S	Engr	Other	Class	M&S	Engr	Other	Class	M&S	Engr	Other
<i>Freshman</i>	THINK/WAYS ¹	-	-	4	Intro Seminar	-	-	4	Intro Seminar	-	-	4
	WAYS ¹	-	-	4	MATH 42	5	-	-	WAYS ¹	-	-	4
	MATH 41	5	-	-	PHYSICS 41	4	-	-	PHYSICS 43	4	-	-
					PHYSICS 42	1	-	-				
	<i>Subtotals</i>	5	0	8	<i>Subtotals</i>	10	0	4	<i>Subtotals</i>	4	0	8
	Total			13	Total			14	Total			12
<i>Sophomore</i>	WAYS ¹	-	-	4	Statistics ^{1,2}	4	-	-	WAYS ¹	-	-	4
	Language	-	-	5	Language	-	-	5	Language	-	-	5
	CME 100	5	-	-	CME 102	5	-	-	ENGR 14	-	4	-
	PHYSICS 45	4	-	-					CS 106A	-	5	-
	<i>Subtotals</i>	9	0	9	<i>Subtotals</i>	9	0	5	<i>Subtotals</i>	0	9	9
	Total			18	Total			14	Total			18
<i>Junior</i>	ENGR 15	-	4	-	ME 203	-	4	-	WAYS ¹	-	-	4
	ENGR 30	-	3	-	ME 103D	-	1	-	ME 70	-	4	-
	ENGR 31/CHEM 31X	4	-	-	WAYS ¹	-	-	4	ME 80	-	4	-
	ME 101	-	4	-	Sci Elective ³	4	-	-	ENGR 40	-	5	-
	<i>Subtotals</i>	4	11	0	<i>Subtotals</i>	4	5	4	<i>Subtotals</i>	0	13	4
	Total			15	Total			13	Total			17
<i>Senior</i>	ME 161	-	4	-	ME 112 ⁴	-	4	-	ME 113	-	4	-
	ME 131A ⁴	-	5	-	ME 131B	-	4	-	ME 140 ⁴	-	5	-
	ME Depth Elective	-	4	-	ME Depth Elect	-	4	-	TIS Course	-	-	4
	UnrestrElective	-	-	3	UnrestrElective ¹	-	-	3	UnrestrElective	-	-	4
	<i>Subtotals</i>	0	13	3	<i>Subtotals</i>	0	12	3	<i>Subtotals</i>	0	9	8
	Total			16	Total			15	Total			17

Total Math & Science Units 45
 Total Engineering Units 72
 Total Other Units 65
Total Units 182

Notes:

- ¹ These courses can be rearranged to accommodate schedule
- ² Statistics course availability varies: STAT 110 is offered in the Autumn; CME106 is offered in the Winter, STAT 116 is offered Autumn and Spring, but requires MATH 52 as a prerequisite.
- ³ After PHYSICS 41/43/45 plus CHEM 31X, 4-5 more units of science is needed. Any number of these units may come from laboratory courses that accompany PHYSICS 41/43/45. *Note:* Science and Math units combined must equal a minimum of 45 units.
- ⁴ ME112, ME131A and ME140 combined fulfill the WIM requirement

Mechanical Engineering

Plan I Math: CME Series, starting with CME 100 (+ AP Calculus Credit)
 Science: PHYSICS 45, One Quarter CHEM (31X) + (AP Physics C Credit)
 Engineering Start: Typical
 Quarter Abroad: None

	<i>Fall</i>				<i>Winter</i>				<i>Spring</i>			
	Class	M&S	Engr	Other	Class	M&S	Engr	Other	Class	M&S	Engr	Other
<i>Freshman</i>	THINK/WAYS ¹	-	-	4	Intro Seminar	-	-	4	Intro Seminar	-	-	4
	WAYS ¹	-	-	4	UnrestrElective ¹	-	-	3	WAYS ¹	-	-	5
	CME 100	5	-	-	CME 102	5	-	-	ENGR 14	-	4	-
	<i>Subtotals</i>	5	0	8	<i>Subtotals</i>	5	0	7	<i>Subtotals</i>	0	4	9
	Total			13	Total			12	Total			13
<i>Sophomore</i>	WAYS ¹	-	-	4	ME 101 ¹	-	4	-	ENGR 40 ¹	-	5	-
	Language	-	-	5	Language	-	-	5	Language	-	-	5
	PHYSICS 45	4	-	-	ENGR 30	-	3	-	ME 70	-	4	-
	ENGR 15 ¹	-	4	-	Statistics ^{1,2}	4	-	-	TIS Course ¹	-	-	4
<i>Subtotals</i>	4	4	9	<i>Subtotals</i>	4	7	5	<i>Subtotals</i>	0	9	9	
	Total			17	Total			16	Total			18
<i>Junior</i>	ME 131A ⁴	-	5	-	ME 131B	-	4	-	ME 140 ⁴	-	5	-
	E 31/CHEM 31X	5	-	-	Science Elective ³	4	-	-	ME 80	-	4	-
	ME 161	-	4	-	CS 106A ¹	-	5	-	UnrestrElective	-	-	3
					UnrestrElective	-	-	3				
<i>Subtotals</i>	5	9	0	<i>Subtotals</i>	4	9	3	<i>Subtotals</i>	0	9	3	
	Total			14	Total			16	Total			12
<i>Senior</i>	ME 203	-	4	-	ME 112 ⁴	-	4	-	ME 113	-	4	-
	ME 103D	-	1	-	ME Depth Elective	-	4	-	ME Depth Elective	-	3	-
	WAYS ¹	-	-	4	WAYS ¹	-	-	4	WAYS ¹	-	-	5
	UnrestrElective	-	-	3								
<i>Subtotals</i>	0	5	7	<i>Subtotals</i>	0	8	4	<i>Subtotals</i>	0	7	5	
	Total			12	Total			12	Total			12

Total Math & Science Units* 27
 Total Engineering Units 71
 Total Other Units 69
Total Units* 167

Notes:

- * Units totals do not include the 10 units of AP Calculus credit associated with placement into CME100 and 8 units of AP Physics C credit associated with placement into PHYSICS 45
- 1 These courses can be rearranged to accommodate schedule
- 2 Statistics course availability varies: STAT 110 is offered in the Autumn; CME106 is offered in the Winter, STAT 116 is offered Autumn and Spring, but requires MATH 52 as a prerequisite.
- 3 After PHYSICS 41/43/45 plus CHEM 31X, 4-5 more units of science is needed. Any number of these units may come from laboratory courses that accompany PHYSICS 41/43/45. *Note:* Science and Math units combined must equal a minimum of 45 units.
- 4 ME112, ME131A and ME140 combined fulfill the WIM requirement

Mechanical Engineering

Plan K Math: CME Series, starting with MATH 41
 Science: One Year CHEM, One Quarter PHYSICS
 Engineering Start: Typical
 Quarter Abroad: None

	Fall			Winter			Spring					
	Class	M&S	Engr	Other	Class	M&S	Engr	Other	Class	M&S	Engr	Other
Freshman	THINK/WAYS ¹	-	-	4	Intro Seminar	-	-	4	Intro Seminar	-	-	4
	WAYS ¹	-	-	4	MATH 41	5	-	-	MATH 42	5	-	-
	CHEM 31X	5	-	-	CHEM 33	5	-	-	CHEM 35	4	-	-
	<i>Subtotals</i>	5	0	8	<i>Subtotals</i>	10	0	4	<i>Subtotals</i>	9	0	4
	Total			13	Total			14	Total			13
Sophomore	WAYS ¹	-	-	4	PHYSICS 41	4	-	-	ENGR 40	-	5	-
	Language	-	-	5	Language	-	-	5	Language	-	-	5
	ENGR 14	-	4	-	CME 102	5	-	-	ME 70	-	4	-
	CME 100	5	-	-	PHYSICS 42	1	-	-	ENGR 30	-	3	-
	<i>Subtotals</i>	5	4	9	<i>Subtotals</i>	10	0	5	<i>Subtotals</i>	0	12	5
	Total			18	Total			15	Total			17
Junior	ME 131A ⁴	-	5	-	ME 131B	-	4	-	ME 140 ⁴	-	5	-
	ME 101	-	4	-	Science Elective ³	4	-	-	ME 80	-	4	-
	Statistics ^{1,2}	4	-	-	CS 106A ¹	-	5	-	TIS Course ¹	-	-	4
	ENGR 15	-	4	-	UnrestrElective	-	-	4	WAYS ¹	-	-	4
	<i>Subtotals</i>	4	13	0	<i>Subtotals</i>	4	9	4	<i>Subtotals</i>	0	9	8
	Total			17	Total			17	Total			17
Senior	ME 203	-	4	-	ME 112 ⁴	-	4	-	ME 113	-	4	-
	ME 103D	-	1	-	ME Depth Elective	-	4	-	ME Depth Elective	-	3	-
	WAYS ¹	-	-	4	WAYS ¹	-	-	4	WAYS ¹	-	-	5
	ME 161	-	4	-	UnrestrElective	-	-	3	UnrestrElective ¹	-	-	3
	<i>Subtotals</i>	0	9	4	<i>Subtotals</i>	0	8	7	<i>Subtotals</i>	0	7	8
	Total			13	Total			15	Total			15

Total Math & Science Units 47
 Total Engineering Units 71
 Total Other Units 66
Total Units 184

Notes:

- These courses can be rearranged to accommodate schedule
- Statistics course availability varies: STAT 110 is offered in the Autumn; CME106 is offered in the Winter, STAT 116 is offered Autumn and Spring, but requires MATH 52 as a prerequisite.
- After CHEM 31X/33/35 plus PHYSICS 41, 5 more units of science is needed. *Note:* Science and Math units combined must equal a minimum of 45 units.
- ME112, ME131A and ME140 combined fulfill the WIM requirement

Mechanical Engineering

Plan M Math: CME Series, starting with MATH 41
 Science: One Year PHYSICS, One Quarter CHEM (31X)
 Engineering Start: Typical
 Quarter Abroad: Autumn, Junior Year

	Fall			Winter			Spring					
	Class	M&S	Engr	Other	Class	M&S	Engr	Other	Class	M&S	Engr	Other
Freshman	THINK/WAYS ¹	-	-	4	Intro Seminar	-	-	4	Intro Seminar	-	-	4
	WAYS ¹	-	-	4	MATH 42	5	-	-	ENGR 14	-	4	-
	MATH 41	5	-	-	PHYSICS 41	4	-	-	PHYSICS 43	4	-	-
					PHYSICS 42	1	-	-				
	<i>Subtotals</i>	5	0	8	<i>Subtotals</i>	10	0	4	<i>Subtotals</i>	4	4	4
	Total			13	Total			14	Total			12
Sophomore	WAYS ¹	-	-	4	Statistics ^{1,2}	4	-	-	ME 101 ¹	-	4	-
	Language	-	-	5	Language	-	-	5	Language	-	-	5
	CME 100	5	-	-	CME 102	5	-	-	ENGR 15	-	4	-
	PHYSICS 45	4	-	-	ENGR 30	-	3	-	CS 106A	-	5	-
	<i>Subtotals</i>	9	0	9	<i>Subtotals</i>	9	3	5	<i>Subtotals</i>	0	13	5
	Total			18	Total			17	Total			18
Junior	QUARTER ABROAD				ME 203	-	4	-	WAYS ¹	-	-	4
	UnrestrElective	-	-	4	ME 103D	-	1	-	ME 70	-	4	-
	WAYS ¹	-	-	4	TIS Course	-	-	4	ME 80	-	4	-
	WAYS ¹	-	-	4	Science Elective ³	4	-	-	ENGR 40	-	5	-
	<i>Subtotals</i>	0	0	12	<i>Subtotals</i>	4	5	4	<i>Subtotals</i>	0	13	4
	Total			12	Total			13	Total			17
Senior	ME 161	-	4	-	ME 112 ⁴	-	4	-	ME 113	-	4	-
	ME 131A ⁴	-	5	-	ME 131B	-	4	-	ME 140 ⁴	-	5	-
	ENGR31/CHEM31X	4	-	-	ME Depth Elective	-	4	-	ME Depth Elective	-	4	-
	UnrestrElective	-	-	3	UnrestrElective ¹	-	-	3	WAYS ¹	-	-	4
	<i>Subtotals</i>	4	9	3	<i>Subtotals</i>	0	12	3	<i>Subtotals</i>	0	13	4
	Total			16	Total			15	Total			17

Total Math & Science Units 45
 Total Engineering Units 72
 Total Other Units 65
Total Units 182

Notes:

- ¹ These courses can be rearranged to accommodate schedule
 - ² Statistics course availability varies: STAT 110 is offered in the Autumn; CME106 is offered in the Winter, STAT 116 is offered Autumn and Spring, but requires MATH 52 as a prerequisite.
 - ³ After PHYSICS 41/43/45 plus ENGR 31/CHEM 31X, 4-5 more units of science is needed. Any number of these units may come from laboratory courses that accompany PHYSICS 41/43/45. Note: Science and Math units combined must equal a minimum of 45 units.
 - ⁴ ME112, ME131A and ME140 combined fulfill the WIM requirement
- ➔ The School of ENGR encourages a quarter abroad. For detail on in-person or online ENGR course options see the Overseas Programs & Engineers page on the UGHB website or Chap 8 of the UGHB.

INSTRUCTIONS FOR DECLARING MAJOR IN MECHANICAL ENGINEERING (ME-BS)

1. Print a copy of your transcript from Axess.
2. Download and complete an ME program sheet from the School of Engineering UGHB website (<http://ughb.stanford.edu>). Please include courses you plan to take as well as those you have already taken. You may pick up a Major Declaration Form from the Mechanical Engineering Student Services Office (Building 530, room 125).
3. Contact the ME Undergraduate Peer Advisor at mepeeradvisor@lists.stanford.edu for an appointment to go over your program sheet and select an advisor.
4. Discuss the program with your advisor and have him/her approve and sign your completed program sheet and major declaration form.
5. Return all completed documents and transcripts to the Student Services Office, Building 530, room 125.
6. Email Kelly Guerriero (kellybg@stanford.edu) to let her know that you have declared your major so that she may approve it.
7. **Attend the quarterly ME Declaration lunch to finalize the process. For more information on the lunch, please speak with Kelly Guerriero.**

Note: The online version of your major (link from the Home or Major Programs page of the UGHB website) is considered the definitive version of 2014-15 requirements; corrections or updates may have been made after the printed and pdf versions were published in August 2014.

★ You must use a program sheet from a year you have been enrolled at Stanford.

Mechanical Engineering Program Sheet (continued)

Engineering Topics (Fundamentals + Depth combined must equal 68 units. See note 4)

Dept	Course	Title	Transfer/AP Approval		Unit	Grade
			✓ if Transfer	Initials	Date	
<i>Engineering Fundamentals (3 courses required)</i>						
ENGR	40 or 40M	Intro Electronics (req'd)				5
ENGR	70A	Programming Methodology (req'd)				5
ENGR		<i>Fundamentals Elective -- CS 106B or X not allowed (see note 5)</i>				
<i>Engineering Fundamentals Unit Total</i>						

Engineering Depth (Be advised, no course may be listed twice on the sheet. No double-counting.)

ENGR	14	Applied Mechanics: Statics (req'd)				4
ENGR	15	Dynamics (req'd)				4
ENGR	30	Engineering Thermodynamics (req'd)				3
ME	70	Introductory Fluids Engineering (req'd)				4
ME	80	Mechanics of Materials (req'd)				4
ME	101	Visual Thinking (req'd)				4
ME	103D	Engineering Drawing (req'd)				1
ME	112	Mechanical Systems Design (req'd) WIM (see note 6)				4
ME	113	Mechanical Engineering Design (req'd)				4
ME	131A	Heat Transfer (req'd) WIM (see note 6)				5
ME	131B	Fluid Mechanics (req'd)				4
ME	140	Advanced Thermal Systems (req'd) WIM (see note 6)				5
ME	161	Dynamic Systems (req'd)				4
ME	203	Manufacturing & Design (req'd)				4

Options to complete ME-BS degree: See note 7; 6 units minimum

Depth Unit Totals:

Mathematics and Science (45 units minimum)

Engineering Topics (Fundamentals + Depth) (68 units minimum)

Program Approvals

Advisor

Printed Name: _____
Signature: _____

Date: _____

Departmental

Printed Name: _____
Signature: _____

Date: _____

School of Engineering (No action required-office use only)

Printed Name: _____
Signature: _____

Date: _____

NOTES (continued from page 1)

- (4) In order to satisfy ABET requirements for graduation, the ME major must take enough courses so that the combined units from Fundamentals & Depth courses add up to a minimum of 68 units. The Fundamentals elective may not count for other req'ts.
- (5) Students may opt to use ENGR 14, 15 or 30 from the required depth courses as the 3rd fundamental. class. However, total units for Fundamentals & Depth combined must be a minimum of 68 units, so additional options courses may be needed to meet unit req'ts. ENGR 70B or X (same as CS 106B or X) are not allowed to fulfill the 3rd fundamental requirement.
- (6) ME112, ME131A and ME140 combined fulfill the Writing in the Major requirement.
- (7) Select two or three courses from: AA283, ENGR105, 110, 240, ME210, 219, 220, 227, 250, 257, 260, 280, 281, 314, 324, 331A, 331B, 345, 348, 351B

PRODUCT DESIGN

The mission of the undergraduate program in Product Design is to graduate designers who can synthesize technology, human factors, and business factors in the service of human need. The program teaches a design process that encourages creativity, craftsmanship, and personal expression, aesthetics, and emphasizes brainstorming and need finding. The course work provides students with the skills necessary to carry projects from initial concept to completion of working prototypes. Students studying product design follow the basic mechanical engineering curriculum and are expected to meet the University requirements for a Bachelor of Science degree. The program prepares students for careers in industry and for graduate study.

Completion of the undergraduate program in Product Design leads to the conferral of the Bachelor of Science in Engineering. The subplan "Product Design" appears on the transcript and on the diploma.

REQUIREMENTS

Mathematics

20 units minimum (one course in statistics recommended, e.g. STATS 60)

Science

23 units minimum

At least 15 units must be from School of Engineering approved list. ¹

Required: One year of Physics 40 series (PHYSICS 41/43/45)

At least 8 additional units must be from behavioral science

Behavioral Science

PSYCH 1 (required)	5 units
PSYCH Elective (courses numbered 30-200)	3-5 units

Engineering Fundamentals

ENGR 40, 40A or 40M (required)	3-5 units
ENGR 70A (same as CS 106A; required)	5 units
Fundamental elective ²	3-4 units

Technology in Society (TIS)

Choose one course from list of SoE-approved courses, Figure 3-3 or at ughb.stanford.edu.

Engineering Depth Required Courses (56 units)

ENGR 14	Intro to Solid Mechanics	4 units
ME 80	Mechanics of Materials	4 units
ME 101	Visual Thinking	4 units
ME 103D ³	Engineering Drawing and Design	1 unit
ME 110	Design Sketching (may be repeated for credit)	2 unit
ME 112 ⁴	Mechanical Systems Design (WIM)	4 units
ME 115A	Product Design Methods	3 units
ME 115B	Human Values in Design	3 units
ME 115C ⁵	Design and Manufacturing (see Note 3)	3 units
ME 203 ³	Manufacturing Technology (see Note 4)	4 units
ME 216A	Advanced Product Design: Needfinding	4 units
ME 216B	Advanced Product Design: Implementation 1	4 units
ME 216C	Advanced Product Design: Implementation 2	4 units
ARTSTUDI	Three Art Studio courses numbered 100 or higher	12 units

Notes:

1. The School of Engineering list of approved science courses can be found in Chapter 3, Figure 3-2 or on the Approved Courses page of the UGHB website.
2. Choose one more fundamental from: ENGR 10, 15, 20, 25B, 25E, 30, 50, 50E, 50M, 60, 62, or 90; Note that CS 106B or X (same as ENGR 70B or X) are not allowed to fulfill the elective requirement.
3. ME 103D and ME 203 should be taken concurrently.
4. ME 112 meets the Writing in the Major (WIM) requirement for Product Design.
5. ME 115C is the only course requirement that can be waived if student takes a quarter overseas. Students should plan their overseas quarter to take place in Sophomore year, or spring quarter of Junior year only. Total Depth units will be reduced by 3; this is approved without petition.

Product Design

(Typical 4-Year Plan without an overseas quarter)

	<i>Fall</i>			<i>Winter</i>			<i>Spring</i>					
	Math/ Sci.	Engr.	Other	Class	Math/ Sci.	Engr.	Other	Class	Math/ Sci.	Engr.	Other	
<i>Freshman</i>	MATH 41	5			MATH 42	5			MATH 51	5		
	PSYCH 1	5			PHYSICS 41	4			PHYSICS 43	4		
	THINK			4	IntroSem			3	Elective			3
					Writing			4	THINK			4
	<i>Subtotals</i>	<i>10</i>	<i>0</i>	<i>4</i>	<i>Subtotals</i>	<i>9</i>	<i>0</i>	<i>7</i>	<i>Subtotals</i>	<i>9</i>	<i>0</i>	<i>7</i>
Total			14	Total			16	Total			16	
<i>Sophomore</i>	Language			5	Language			5	Language			5
	Elective			4	ME 101		4		Elective		3	
	PHYSICS 45	4			STATS 60	5			PSYCH elective	3		
	ENGR 40		5		Writing			4	ARTSTUDI elective			4
	<i>Subtotals</i>	<i>4</i>	<i>5</i>	<i>9</i>	<i>Subtotals</i>	<i>5</i>	<i>4</i>	<i>9</i>	<i>Subtotals</i>	<i>3</i>	<i>3</i>	<i>9</i>
Total			18	Total			18	Total			15	
<i>Junior</i>	ME115A		3		ME 115B		3		ME115C		3	
	ME 203*		4		ENGR 70A		5		ENGR 14		4	
	ME 103D*		1		ARTSTUDI Elect.		4		Elective		3	
	ENGR Fund		4		Elective			3	ARTSTUDI Elect.		4	
					ME110		1					
<i>Subtotals</i>	<i>0</i>	<i>12</i>	<i>0</i>	<i>Subtotals</i>	<i>0</i>	<i>13</i>	<i>3</i>	<i>Subtotals</i>	<i>0</i>	<i>7</i>	<i>7</i>	
Total			12	Total			16	Total			14	
<i>Senior</i>	ME 216A		4		ME 216B		4		ME 216C		4	
	Sci Elective	3			ME 112**		4		TiS Course			4
	ME 80		4		Elective			3	Elective			3
	Elective			3	Elective			3	Elective			3
	<i>Subtotals</i>	<i>3</i>	<i>8</i>	<i>3</i>	<i>Subtotals</i>	<i>0</i>	<i>8</i>	<i>6</i>	<i>Subtotals</i>	<i>0</i>	<i>4</i>	<i>10</i>
Total			14	Total			14	Total			14	

Total Math & Science Units: 43
 Total Other Units: 138
Total Units: 181

Notes: * ME203 and ME103D should be taken concurrently.

**ME112 fulfills the WIM requirement

Product Design

(Typical 4-Year Plan with an overseas quarter)

	<i>Fall</i>				<i>Winter</i>				<i>Spring</i>			
	Math/ Sci.	Engr.	Other		Math/ Sci.	Engr.	Other		Math/ Sci.	Engr.	Other	
<i>Freshman</i>	Class				Class				Class			
	MATH 41	5			MATH 42	5			MATH 51	5		
	PSYCH 1	5			PHYSICS 41	4			PHYSICS 43	4		
	THINK		4		Into Sem		3		ENGR 14		4	
					Writing		4		THINK		4	
	<i>Subtotals</i>	10	0	4	<i>Subtotals</i>	9	0	7	<i>Subtotals</i>	9	4	4
	Total			14	Total			16	Total			17
<i>Sophomore</i>	Language			5	Language			5	Language		5	
	Elective			4	ME 101		4		ME80		4	
	PHYSICS 45	4			STATS 60	5			PSYCH elective	3		
	ENGR 40		5		Writing		4		ARTSTUDI elective		4	
	<i>Subtotals</i>	4	5	9	<i>Subtotals</i>	5	4	9	<i>Subtotals</i>	3	8	5
	Total			18	Total			18	Total			16
<i>Junior</i>	ME115A		3		ME 115B		3		Overseas studies (waive ME115C)		12	
	ME 203*		4		ENGR 70A		5					
	ME 103D*		1		ARTSTUDI Elective		4					
	ENGR Fund		4		Elective		3					
					ME110		2					
	<i>Subtotals</i>	0	12	0	<i>Subtotals</i>	0	10	7	<i>Subtotals</i>	0	0	12
	Total			12	Total			17	Total			12
<i>Senior</i>	ME 216A		4		ME 216B		4		ME216C		4	
	ARTSTUDI Elect.		4		ME 112**		4		TIS Course		4	
	Sci Elective	3			Elective		3		Elective		3	
	Elective			3	Elective		3		Elective		3	
	<i>Subtotals</i>	3	8	3	<i>Subtotals</i>	0	8	6	<i>Subtotals</i>	0	4	10
	Total			14	Total			14	Total			14

Total Math & Science Units: 43
 Total Other Units: 139
Total Units: 182

Notes: *ME203 and ME103D should be taken concurrently.

**ME112 fulfills the WIM requirement

INSTRUCTIONS FOR DECLARING MAJOR IN ENGINEERING: PRODUCT DESIGN (ENGR-BS: PD)

Detailed instructions can be obtained from the ME Student Services Office (Building 530, Room 125)

1. Print a copy of your transcript from Axess.
2. Download and complete the program sheet from the School of Engineering web site at <http://ughb.stanford.edu>. If you need instructions on how to download, consult the School of Engineering Student Affairs Office in 135 Huang. Please note: When completing the sheet, include courses you plan to take as well as those you have already taken.
3. Pick up a Product Design major declaration form from the Student Services Office in Building 530.
4. Identify an undergraduate program advisor from the list on the back of the major declaration form. If you prefer, the Student Services Office will assign one for you.
5. Discuss the program with your advisor and have him/her approve the program sheet AND the declaration form.
6. Return completed documents to the ME Student Services Office
7. Login to Axess and formally declare your major. **NOTE: Select “Engineering” as your major (NOT Mechanical Engineering), with a subplan in Product Design.**
8. Email Indrani Stangl (indrani@stanford.edu) to let her know that you have declared your major so that she may approve it.

Note: The online version of your major (link from the Home or Major Programs page of the UGHB website) is considered the definitive version of 2014-15 requirements; corrections or updates may have been made after the printed and pdf versions were published in August 2014.

★ You must use a program sheet from a year you have been enrolled at Stanford.

Stanford University • School of Engineering
Product Design
2014–2015 Program Sheet
prior to the last quarter of senior year.

Follow all requirements as stated for the year of the program sheet used.

Name: _____ SU ID #: _____
 Phone: _____ Email: _____
 Today's Date: _____ Month/Yr B.S. expected: _____

Mathematics and Science Requirement

Dept	Course	Title	Transfer/AP Approval			Units	Grade
			✓ if Transfer	Initials	Date		
<i>Mathematics (20 units minimum; see Note 1)</i>							
<i>Mathematics Unit Total (20 units minimum)</i>							

SoE Science (15 units minimum; see note 1)

PHYS	41	Mechanics (req'd)				4	
PHYS	43	Electricity and Magnetism (req'd)				4	
PHYS	45	Light and Heat (req'd)				4	
		Science Elective (from SoE approved list, see note 2)				3 to 5	
<i>SOE Science Unit Total (15 units minimum)</i>							

Behavioral Sciences (8 units minimum)

PSYCH	1	Intro to Psychology (req'd)				5	
PSYCH		Psychology Elective (3-5 units, PSYCH 30-200; see Note 3)					
<i>Behavioral Science Unit Total (8 units minimum)</i>							

Science Unit Total (SoE + Behavioral) (23 units minimum) _____
Mathematics and Science Unit Total (43 units minimum) _____

Technology in Society Requirement (1 course required, 3 units)

		See SoE Approved Courses list at <ughb.stanford.edu>					
--	--	--	--	--	--	--	--

NOTES

- * **All courses taken for the major must be taken for a letter grade if offered by the instructor.**
 - * This form is available as an Excel file at <http://ughb.stanford.edu/>; you must use a program sheet from a year you
 - * Read all emails from your major department; this is the SoE's only method of conveying key information to
 - * Minimum Grade Point Average (GPA) for all courses in Engineering Fundamentals and Product Design Depth
 - * Transfer and AP credits in Math, Science, Fundamentals, & TIS must be approved by the SoE Dean's office.
 - * All courses listed on this form must be listed under only one category; no double-counting. Delete courses not taken.
- (1) AP units can be applied; have these approved by SoE Dean's Office before final quarter.
 (2) At least 15 units must be from the School of Engineering approved science list in the undergraduate handbook
 (3) If the PSYCH elective was taken prior to the req't being increased to 3 units min. in 2012-13, it is allowed without petition to be one unit short in the Science/Behavioral Sciences section.

Engineering Fundamentals (3 courses required, 11 units minimum)

ENGR	40+	Introductory Electronics 40 or 40A or 40M (one req'd)				3 or 5
ENGR	70A	Programming Methodology (req'd)				5
		Fundamentals Elective: See Note 4, CS 106B or X (ENGR 70B or X) not allowed.				3 or 4
<i>Engineering Fundamentals Total (3 courses required)</i>						

Product Design Depth (56 units)

Dept	Course	Title	Transfer/AP Approval			Units	Grade
			✓ if Transfer	Initials	Date		
ENGR	14	Introduction to Solid Mechanics (req'd; see Note 5)				4	
ME	80	Mechanics of Materials (req'd)				4	
ME	101	Visual Thinking (req'd)				4	
ME	103D	Engineering Drawing and Design (req'd, see Note 6)				1	
ME	110	Design Sketching (req'd; see Note 5)				2	
ME	112	Mechanical Engineering Design (req'd; see note 7)				4	
ME	115A	Introduction to Human Values in Design (req'd)				3	
ME	115B	Product Design Methods (req'd)				3	
ME	115C	Design and Business Factors (req'd; see Note 8)				3	
ME	203	Design and Manufacturing (req'd, WIM; see Note 6)				4	
ME	216A	Advanced Product Design: Needfinding (req'd)				4	
ME	216B	Advanced Product Design: Implementation 1 (req'd)				4	
ME	216C	Advanced Product Design: Implementation 2 (req'd)				4	
ARTSTUDI		Art Studio Elective (100 series or higher)				4	
ARTSTUDI		Art Studio Elective (100 series or higher)				4	
ARTSTUDI		Art Studio Elective (100 series or higher)				4	
<i>Product Design Engineering Depth Total (56 units)</i>							

Program Totals

Mathematics and Science (43 units minimum)

Product Design Depth (56 units minimum)

Program Approvals

Advisor

Printed Name: _____ Date: _____
 Signature: _____

Departmental

Printed Name: _____ Date: _____
 Signature: _____

School of Engineering (No action required -- office use only)

Printed Name: _____ Date: _____
 Signature: _____

NOTES (continued from page 1)

- (4) Choose one more fundamental from: ENGR 10, 15, 20, 25B or E, 30, 50, 50E, 50M, 60, 62, 90; CS 106B or X (ENGR 70B or X) are not allowed to fulfill elective.
- (5) If ENGR 14 and/or ME 110 were taken prior to the courses being offered for 4 and 2 units, depth total may be reduced by 1 and/or 2 units with no petition required.
- (6) ME 103D and 203 should be taken concurrently.
- (7) ME 112 meets the Writing in the Major(WIM) requirement.
- (8) ME 115C is the only course that can be waived if student takes a quarter overseas. Students should plan their overseas quarter to take place in Sophomore year, or spring quarter of Junior year only. Total Depth units will be reduced by 3; this is approved without petition.

6. MINORS AND HONORS PROGRAMS

□ *Program sheets for all minor programs can be found on the UGHB website* □

Many of the School's departments offer an undergraduate minor to interested students. The requirements for each of the available minors are listed on the pages that follow. To obtain more information, contact a department's Undergraduate Program representative or the Office of Student Affairs in 135 Huang Engineering Center.

General requirements and policies for a minor in the School of Engineering are:

1. A minor consists of a set of courses totaling not less than 20 and not more than 36 units, with a minimum of six courses of at least 3 units each. These courses must be taken for a letter grade except where letter grades are not offered. A minimum total GPA of 2.0 must be maintained in courses taken for the minor; departments may choose to set a higher GPA.
2. The set of courses should be sufficiently coherent as to present a body of knowledge within a discipline or sub-discipline.
3. Students may not overlap (double-count) courses for completing major and minor requirements, *unless*:
 - a) Overlapping courses constitute introductory skill requirements (for example, introductory math and statistics)
 - b) Overlapping courses enable the student to meet School of Engineering requirements, such as introductory science, the TIS requirement, and engineering fundamentals. However, courses used for the major and/or minor depth/core must not be duplicated within any other of the student's degree programs. *Example*: An MS&E major using CS 103 to fulfill the Depth requirement cannot also use it to fulfill CS minor requirements. The student should consult with their advisor or departmental student services contact to find an acceptable substitute course for the minor program. A Petition to Deviate to waive the course for the minor may also be submitted; however, even if approved, in no case may the total unit count fall below the minimum set by the minor department.
4. Departmentally-based minor programs are structured at the discretion of the sponsoring department, subject only to requirements (1), (2), and (3) above.

No "General Engineering" minor is offered. University policy and procedures for declaring a minor and limitations on No Credit units, and so forth, may be found in the *Stanford Bulletin* or at the Student Services Center in 2nd floor Tresidder Union. Minors must be officially declared by students no later than the deadline for their application to graduate, although individual departments may set an earlier deadline. All *Multiple-Major Minor* forms for students in an engineering program must be signed by the Dean's Office (Darlene Lazar in 135 Huang).

MINOR PROGRAMS.

AERONAUTICS AND ASTRONAUTICS MINOR (ENGR-MINOR, AA)

The program sheet for the AA minor program can be found on the UGHB website.

The Aero/Astro minor introduces undergraduates to the key elements of modern aerospace systems. Within the minor, students may focus on aircraft, spacecraft, or disciplines relevant to both. The course requirements for the minor are listed in the following table.

COURSES FULFILLING THE MINOR IN AERONAUTICS AND ASTRONAUTICS[†]

Core:	Title	Units
ENGR 14*	Introduction to Solid Mechanics	4
ENGR 15*	Dynamics	4
ENGR 30*	Engineering Thermodynamics	3
AA 100	Introduction to Aero/Astro	3
ME 70	Introductory Fluids Engineering	4
ME 131A	Heat Transfer	3
	<i>Core total</i>	21-23

Upper division electives:		
2 courses from one of the elective areas below		6-10
1 course from a second elective area below		3-5
	<i>Program total</i>	30-38

Elective areas:		
Dynamics and Controls:		
ENGR 105	Feedback Control Design	3
ENGR 205	Introduction to Control Design Techniques	3
AA 203	Introduction to Optimal Control Theory	3
AA 222	Introduction to Multidisciplinary Design Optimization	3-4
AA 242A	Classical Dynamics	3
AA 271A	Dynamics and Control of Spacecraft/Aircraft	3
Aerospace Systems Synthesis/Design:		
AA 236A	Spacecraft Design	3-5
AA 236B	Spacecraft Design Laboratory	3-5
AA 241A	Introduction to Aircraft Design, Synthesis, and Analysis	3
AA 241B	Introduction to Aircraft Design, Synthesis, and Analysis	3
AA 284B	Propulsion System Design Laboratory	3
Fluids:		
AA 200	Applied Aerodynamics	3
AA 201A	Fundamentals of Acoustics	3
AA 210A	Fundamentals of Compressible Flow	3
AA 214A/CME 206	Introduction to Numerical Methods for Engineering	3
AA 283	Aircraft and Rocket Propulsion	3
ME 131B	Fluid Mechanics: Compressible Flow and Turbomachinery	4
ME 140	Advanced Thermal Systems	5
Continues on next page		

Structures:		
AA 240A	Analysis of Structures	3
AA 240B	Analysis of Structure II	3
AA 256	Mechanics of Composites	3
AA 280	Smart Structures	3
ME 335A	Finite Element Analysis	3
Notes	† Courses cannot be double-counted within a major and a minor, or within multiple minors: If any of the core classes are an integral part of the student's major or of another minor program, the Aero/Astro advisor can help select substitute courses to fulfill the Aero/Astro requirements.	
	* ENGR 14, 15, or 30 are waived as minor requirements if already taken as part of the major.	

CHEMICAL ENGINEERING MINOR (CHEME-MINOR)

The program sheet for the CHEME minor program can be found on the UGHB website.

The courses required for the Chemical Engineering minor appear in the following table.

COURSES FULFILLING THE MINOR IN CHEMICAL ENGINEERING

Class	Title	Units
ENGR 20	Introduction to Chemical Engineering	3
CHEMENG 100	Chemical Process Modeling, Dynamics, and Control	3
CHEMENG 110	Equilibrium Thermodynamics	3
CHEMENG 120A	Fluid Mechanics	4
CHEMENG 120B	Energy and Mass Transport	4
CHEMENG 140 <i>or</i>	Micro & Nanoscale Fabrication Engineering	3
CHEMENG 142 <i>or</i>	Catalysis with Applications in Energy Transformations	3
CHEMENG 160 <i>or</i>	Polymer Science and Engineering	3
CHEMENG 162 <i>or</i>	Polymers for Energy and Environmental Sustainability	3
CHEMENG 174 <i>or</i>	Environmental Microbiology	3
CHEMENG 181 <i>or</i>	Biochemistry I	3
CHEMENG 196	Entrepreneurship in Engineering & Science-based Industries	3
CHEMENG 170	Kinetics and Reactor Design	3
CHEMENG 180	Chemical Engineering Plant Design	4
CHEMENG 185A	Chemical Engineering Laboratory A	4
CHEM 171	Physical Chemistry - Chemical Thermodynamics	3
	<i>Program total</i>	34

CIVIL ENGINEERING MINOR (CE-MINOR)

The program sheet for the CE minor program can be found on the UGHB website.

The civil engineering minor is intended to give students a focused introduction to one or more areas of civil engineering. Departmental expertise and undergraduate course offerings are available in the areas of Architectural Design, Construction Engineering and Management, and Structural and Geotechnical Engineering. Students interested in Environmental and Water Studies should refer to the environmental engineering minor. The minimum prerequisite for a civil engineering minor is MATH 42 (or MATH 21); however many courses of interest require PHYSICS 41 and/or MATH 51 as prerequisites. Students should recognize that a minor in civil engineering is not an ABET-accredited degree program.

Since undergraduates having widely varying backgrounds may be interested in obtaining a civil engineering minor, and the field itself is broad, no single set of course requirements will be appropriate for all students. Instead, interested students are encouraged to propose their own set of courses within the guidelines listed below. Additional information, including example minor programs, is given on the CEE website.

(CE Minor continued on next page)

General guidelines and procedures for the minor in civil engineering are:

1. A civil engineering minor must contain at least 24 units of engineering coursework not taken for the major, and must consist of at least six classes of a least 3 units each of letter-graded work, except where letter grades are not offered. Coursework must conform to the School of Engineering minor requirements published in the *Stanford Bulletin* and in this Handbook.
2. To declare a minor with the CEE department, students must complete a Civil/Environmental Minor Program form. Professor Anne Kiremidian (ask@stanford.edu), is the advisor for minors in Civil Engineering. John Barton (jhbarton@stanford.edu) is the advisor for minors in the CE Architectural Design track. Students must consult with the appropriate advisor in developing their minor program, obtain the advisor's approval (including signature) of their study list on the CEE Minor Program Sheet, and turn in the form to Jill Filice in CEE Student Services, Room 316 Y2E2.
3. To declare the minor in ACESS, the student must complete a **Major-Minor & Multiple-Major Course Approval Form** available online at the SU Registrar site or in the CEE Student Services office. Follow the instructions on the form, which includes obtaining a signature from the Dean's Office (Darlene Lazar, 135 Huang) before submitting the original to the Student Services Center Office and a copy to Jill in CEE.

Apply for the CE minor on ACESS. The CEE Student Services staff will then check the Major-Minor & Multiple-Major Course Approval Form copy with the CEE Minor Program Sheet to accept the declaration. **Minors must be officially declared and all courses completed (or in progress) no later than the deadline for a student's application to graduate.**

COMPUTER SCIENCE MINOR (CS-MINOR)

The program sheet for the CS minor program can be found on the UGHB website.

The courses necessary to fulfill the requirements for the minor in Computer Science are shown in the table below (continuing on the next page). In addition, students must complete the standard mathematics sequence through MATH 51 as a prerequisite.

COURSES FULFILLING THE MINOR IN COMPUTER SCIENCE

<i>Introductory programming:</i>		Units
CS 106B or	Programming Abstractions	5
CS 106X	Programming Abstractions (Accelerated)	5
<i>Core:</i>		
CS 103	Mathematical Foundations of Computing	5
CS107	Computer Organization and Systems	5
CS109	Introduction to Probability for Computer Scientists	5
<i>Core total (including introductory programming)</i>		20
<i>Electives:</i>		
2 courses from two different areas taken from the list below		6-9
<i>Program Total</i>		26-29
<i>Elective areas:</i>		
<i>Software:</i>		
CS 108	Object-Oriented Systems Design	4
CS 110	Principles of Computer Systems	5
<i>Systems:</i>		
CS 140	Operating Systems	4
CS 143	Compilers	4
CS 144	Introduction to Computer Networking	4
CS 145	Introduction to Databases	4
CS 148	Introduction to Computer Graphics	4
<i>Theory:</i>		
CS 154	Automata and Complexity Theory	4
CS 157	Logic and Automated Reasoning	3
CS 161	Design and Analysis of Algorithms	5
<i>Artificial Intelligence:</i>		
CS 121 or	Introduction to Artificial Intelligence	3
CS 221	Artificial Intelligence: Principles and Techniques	4
CS 124	From Languages to Information	4
CS 229	Machine Learning	3-4
<i>Human-Computer Interaction:</i>		
CS 147	Introduction to HCI Design	4
<i>Notes:</i>		
*AP units may be used to meet the introductory programming requirement.		
*All courses must be taken for a letter grade; the minimum acceptable GPA is 2.0.		
*Only CS106 B/X may be double-counted towards both major and minor requirements.		
*A maximum of one transfer credit course may be counted towards the minor requirements.		

ELECTRICAL ENGINEERING MINOR (EE-MINOR)

The program sheet for the EE minor program can be found on the UGHB website.

The options for completing a minor in Electrical Engineering are outlined below. Students must complete a minimum of 25 units, as follows:

COURSES FULFILLING THE MINOR IN ELECTRICAL ENGINEERING

Select one of the following fundamentals:	Units

EE 65 or	Modern Physics for Engineers	3
ENGR 40 or	Introductory Electronics	5
ENGR 40M or	An Intro to Making: What is EE	5
ENGR 40P/EE 41	Physics of Electrical Engineering (not offered 2014-15)	5
Select one of the following core options:		
Option I		
EE 101A	Circuits I	4
EE 101B	Circuits II	4
Option II		
EE 102A	Signal Processing and Linear Systems I	4
EE 102B	Signal Processing and Linear Systems II	4
Option III		
EE 108	Digital Systems Design	4
EE 180	Digital Systems Architecture	4
Core Electives:		
Four letter-graded EE or EE-related courses at the 100 level or higher		12 min.
Note: CS 107 is a required prerequisite for EE 180, but can count as one of the four electives.		
	<i>Program total</i>	23-25 min.

ENVIRONMENTAL SYSTEMS ENGINEERING MINOR (ENVSE-MINOR)

The program sheet for the ENVSE minor program can be found on the UGHB website.

The Environmental Systems Engineering minor is intended to give students a focused introduction to one or more areas of Environmental Systems Engineering. Departmental expertise and undergraduate course offerings are available in the areas of environmental engineering and science, environmental fluid mechanics and hydrology, and atmosphere/ energy. The minimum prerequisite for an Environmental Systems Engineering minor is MATH 42 (or MATH 21); however, many courses of interest require PHYSICS 41 and/or MATH 51 as prerequisites. Students should recognize that a minor in Environmental Systems Engineering is not an ABET-accredited degree program.

Since undergraduates having widely varying backgrounds may be interested in obtaining an environmental systems engineering minor, no single set of course requirements is appropriate for all students. Instead, interested students are encouraged to propose their own set of courses within the guidelines listed below. Additional information, including example minor programs, are given on the CEE website.

General guidelines and procedures for the minor in environmental systems engineering are:

1. An Environmental Systems Engineering minor must contain at least 24 units of engineering coursework not taken for the major, and must consist of at least six classes of at least 3 units each of letter-graded work, except where letter grades are not offered. Coursework must conform to the School of Engineering (SoE) minor requirements published in the *Stanford Bulletin* and in this Handbook.

2. To declare a minor with the CEE Department, students must complete a Civil/Environmental Minor Program form. Professor Lynn Hildemann: (hildemann@stanford.edu) is the advisor for minors in Environmental Systems Engineering. Students must consult with Prof. Hildemann in developing their minor program and must obtain her approval (including signature) of their study list on the CEE Environmental Systems Engineering Minor Program sheet and turn it in to CEE Student Services in Room 316, Y2E2.
3. To declare the minor in ACESS, students must first complete a **Major-Minor & Multiple-Major Course Approval Form**, available on the Registrar website or in the CEE Student Services office. Follow the instructions on the form, which include obtaining a signature from the Dean's Office (Darlene Lazar) before submitting the original to the Student Services Center Office and a copy to Jill Filice in 316 Y2E2.

Apply for the Environmental Systems Engineering minor on ACESS. The CEE Student Services staff will check the Major-Minor & Multiple-Major Course Approval Form to accept the declaration. **Minors must be officially declared and all courses completed (or in progress) no later than the deadline for a student's application to graduate.**

MANAGEMENT SCIENCE AND ENGINEERING MINOR (MGTSC-MINOR)

The program sheet for the MGTSC minor program can be found on the UGHB website.

The following courses fulfill the requirements for the minor in Management Science and Engineering. In addition, students must complete prerequisites CME 100 (or MATH 51) and CS 106A.

COURSES FULFILLING THE MINOR IN MANAGEMENT SCIENCE AND ENGINEERING

Required (six courses):		Units
MS&E 111	Introduction to Optimization	4
MS&E 120	Probabilistic Analysis	5
MS&E 121	Introduction to Stochastic Modeling	4
MS&E 125	Introduction to Applied Statistics	4
MS&E XXX	100- or 200-level elective course	3
MS&E XXX	100- or 200-level elective course	3
	<i>Program total</i>	<i>27</i>
<i>Recommended:</i>		
In addition to the required background and minor courses, it is recommended that students also take the following courses.		
ECON 1	Economic Analysis I	5
MS&E 140	Accounting for Managers and Entrepreneurs (may be used as one of the required electives above) or MS&E 140X Financial Accounting Concepts and Analysis	2-4

MATERIALS SCIENCE AND ENGINEERING MINOR (MATSC-MINOR)

A minor in the Department of Materials Science and Engineering allows interested students to explore the role of materials in modern technology and to gain understanding of the fundamental processes that govern materials behavior. The courses listed in the following table fulfill the requirements. All courses for the minor requirements must be taken for a letter grade if offered by the instructor.

COURSES FULFILLING THE MINOR IN MATERIALS SCIENCE AND ENGINEERING

Core: Choose one of the following:		Units
ENGR 50	Introduction to Materials Science, Nantechology Emphasis	4
ENGR 50E	Introduction to Materials Science, Energy Emphasis	4
ENGR 50M	Introduction to Materials Science, Biomaterials Emphasis	4
	<i>Core total</i>	4
Materials Science and Engineering Depth (Select six of the following):		
MATSCI 151	Microstructure and Mechanical Properties	4
MATSCI 152	Electronic Materials Engineering	4
MATSCI 153	Nanostructure and Characterization	4
MATSCI 154	Solid State Thermodynamics	4
MATSCI 155	Nanomaterials Synthesis	4
MATSCI 156	Solar Cells, Fuel Cells, and Batteries: Materials for the Energy Solution	4
MATSCI 157	Quantum Mechanics of Nanoscale Materials	4
MATSCI 160	Nanomaterials Laboratory	4
MATSCI 161	Nanocharacterization Laboratory	4
MATSCI 162	X-Ray Diffraction Laboratory	4
MATSCI 163	Mechanical Behavior Laboratory	4
MATSCI 164	Electronic and Photonic Materials and Devices Laboratory	4
MATSCI 165	Nanoscale Materials Physics Computation Laboratory	4
MATSCI 190	Organic and Biological Materials	4
MATSCI 192	Solid State Thermodynamics	4
MATSCI 193	Materials Chemistry	4
MATSCI 194	Thermodynamics and Phase Equilibria	4
MATSCI 195	Waves and Diffraction in Solids	4
MATSCI 196	Imperfections in Crystalline Solids	4
MATSCI 197	Rate Processes in Materials	4
MATSCI 198	Mechanical Properties of Materials	4
MATSCI 199	Electronic and Optical Properties of Solids	4
	Depth unit total	24
	Program Unit Total	28

MECHANICAL ENGINEERING MINOR (ME-MINOR)

The program sheet for the ME minor program can be found on the UGHB website.

There are three options for students interested in a minor in Mechanical Engineering: A general minor that exposes students to the breadth of the field, and two specialized minors—Thermosciences and Mechanical Design—that allow students to pursue a particular area in more depth. The requirements for each of these minors are listed below.

General Minor in Mechanical Engineering

This minor aims to expose students to the breadth of Mechanical Engineering in terms of topics and of analytic and design activities. Students interested in this minor must take the following courses as prerequisites: MATH 41, MATH 42, and PHYSICS 41.

Core		Units
ENGR 14*	Introduction to Solid Mechanics	4
ENGR 15*	Dynamics	4
ENGR 30*	Engineering of Thermodynamics	3
ME 70	Introductory Fluids Engineering	4
ME 101	Visual Thinking	4
<i>Plus any two of the following electives:</i>		
ME 80	Mechanics of Materials	4
ME 131A	Heat Transfer	5
ME 161	Dynamic Systems	4
ME 203	Manufacturing and Design	4
Program Total		28

Thermosciences Minor in Mechanical Engineering

Students interested in this minor must take the following courses as prerequisites: MATH 41, MATH 42, MATH 51 (or CME 100), and PHYSICS 41.

Core:		Units
ENGR 14*	Introduction to Solid Mechanics	4
ENGR 30*	Thermodynamics	3
ME 70	Introductory Fluids Engineering	4
ME 131A	Heat Transfer	5
ME 131B	Fluid Mechanics	4
ME 140	Advanced Thermal Systems	5
Program Total		25

Mechanical Design Minor in Mechanical Engineering

This minor aims to expose students to design activities, supported by analysis. Students interested in this minor must take the following courses as prerequisites: MATH 41, MATH 42, and PHYSICS 41.

Core		Units
ENGR 14*	Introduction to Solid Mechanics	4
ENGR 15*	Dynamics	4
ME 80	Mechanics of Materials	4
ME 101	Visual Thinking	4
ME 112	Mechanical Systems Design	4
ME 203	Manufacturing and Design	4
<i>Plus one of the following:</i>		
ME 113	Mechanical Engineering Design	4
ME 210	Introduction to Mechatronics	4
ME 220	Introduction to Sensors	3
Program Total		27-28

*For all of the above minor programs: If ENGR14, 15, or 30 will be taken for the major requirements, other courses may be substituted for these minor requirements via petition. The total number of required units remains the same as listed in the above guidelines.

HONORS PROGRAMS

The departmental honors programs are designed to allow undergraduates with strong academic records and enthusiasm for independent research to engage in a significant project leading to a degree with departmental honors. This option is particularly valuable for students who intend to pursue a Ph.D. after college because it provides research experience that helps prepare a student for doctoral-level work. Typically, these programs are competitive in terms of their admission and also require that the student find a faculty member to supervise the work. Honors programs currently exist in Architectural Design, Biomechanical Engineering, Biomedical Computation, Chemical Engineering, Civil Engineering, Computer Science, Electrical Engineering, Engineering Physics, Environmental Engineering, and Mechanical Engineering; you may contact the faculty of your own department within the School if you would like them to consider establishing an honors program as well. The honors programs offered for 2014-2015 are described below.

Note: Only honors theses completed, handed in, and approved by honors advisors by the third week of May are eligible to be nominated for University awards (the Firestone Medal and Kennedy Prize).

ARCHITECTURAL DESIGN

The AD honors program offers eligible students the opportunity to engage in guided original research, or project design, over the course of an academic year. For interested students the following outlines the process:

(1) The student must submit a letter applying for the Honors option endorsed by the student's primary advisor and honors advisor and submitted to the student services office in CEE.

Applications must be received in the fourth quarter prior to graduation. It is strongly suggested that students meet with the Architectural Design Program Director well in advance of submitting an application.

(2) The student must maintain a GPA of at least 3.5.

(3) The student must complete an honors thesis or project. The timing and deadlines are to be decided by the program or honors advisor. At least one member of the evaluation committee must be a member of the Academic Council in the School of Engineering.

(4) The student must present the work in an appropriate forum, e.g., in the same session as honors theses are presented in the department of the advisor. All honors programs require some public presentation of the thesis or project.

ATMOSPHERE AND ENERGY

The A/E honors program offers eligible students the opportunity to engage in guided original research, or project design, over the course of an academic year. For interested students, please adhere to the following guidelines:

- (1) Write up and submit a 1-2 page letter applying to the Honors Program in A/E. In the letter, describe the problem that you will investigate. Sign the letter and obtain signatures from your current primary advisor and your proposed Honors advisor, if different, and submit the letter to the student services office in the Department of Civil and Environmental Engineering (CEE). The application must include an unofficial Stanford transcript. Applications must be received in the fourth quarter prior to graduation. It is strongly suggested you meet with your proposed Honors advisor well in advance of submitting an application.
- (2) You must maintain a GPA of at least 3.5.
- (3) You must complete an honors thesis or project over a period of three quarters. The typical length of the written report is 15-20 pages. The deadline for submission of the report is to be decided by the Honors advisor, but should be no later than the end of the third week in May.
- (4) Your report must be read and evaluated by your Honors advisor and one other reader. It is your responsibility to find and obtain both the advisor and reader. At least one of the two must be a member of the Academic Council in the School of Engineering.
- (5) You must present your completed work in an appropriate forum, e.g., in the same session as honors theses are presented in the department of the advisor. All honors programs require some public presentation of the thesis or project.
- (6) You may take up to 10 units of CEE 199H toward your thesis (optional). However, you must take ENGR 202S or its equivalent (School of Engineering Writing Course) sometime during your time at Stanford (required). Units for the writing class are beyond those required for the A/E major.
- (7) Two copies of the signed thesis must be provided to the CEE Student Services office no later than two weeks before the end of your graduation quarter.

BIOENGINEERING

The School of Engineering offers a program leading to a Bachelor of Science in Engineering: Bioengineering with Honors (ENGR-BSH, BIOE). This program provides a unique opportunity for qualified BioE majors to conduct independent research at an advanced level with a faculty research advisor and documented in an honors thesis.

(continued on the next page)

Honors Eligibility Criteria:

- GPA of 3.5 or higher
- Arrangement with a BioE faculty member (or a faculty member from another department approved by the BioE Undergraduate Curriculum Committee) who agrees to serve as the honors research advisor, plus a second faculty member who will read the thesis and give feedback before endorsement. One of the two must be a member of the Academic Council and in the School of Engineering.

Application Instructions:

Students who meet the eligibility criteria and wish to be considered for the honors program must submit the following materials to Teri Hanks in the Bioengineering Student Services Office, no later than the second week of the Spring Quarter of junior year:

- An Undergraduate Honors Program Application Sheet signed by your honors research advisor and thesis reader (this form can be picked up in the BioE Student Services Office)
- 1-2 page thesis proposal
- 4-year plan highlighting your honors research
- Supplemental form (one page max; pick-up in the BioE Student Services Office)
- Unofficial Stanford transcript (in Axess)

Applications are subject to the review and final approval by the Undergraduate Curriculum Committee. Applicants and thesis advisors will receive a decision notification via email.

Requirements in order to receive departmental honors:

- Declare the honors program in Axess (ENGR-BSH, subplan: BIOE)
- Maintain an overall GPA of 3.5 as calculated on your unofficial transcript.
- Complete at least two quarters of research with a minimum of nine units of BIOE 191 or BIOE 191X for a letter grade; up to three units may be used towards your BioE depth electives requirements.
- Submit a completed thesis draft to the research advisor and thesis reader by the first week of Spring Quarter.
- Participate in a public presentation of either your honors thesis or project at one of the following:
 - a public colloquium sponsored by the department
 - an approved poster session
 - an approved comparable public event
- Submit two bound copies plus one PC-compatible CD-ROM of your honors thesis to Teri Hanks in Bioengineering Student Services Office by the second Monday of May.

BIOMECHANICAL ENGINEERING

The School of Engineering offers a program leading to a Bachelor of Science in Engineering: Biomechanical Engineering with Honors. This program provides a unique opportunity for qualified BME majors to conduct independent study and research related to biomechanical engineering at an advanced level with a faculty mentor.

Honors Criteria:

- GPA of 3.5 or higher in the major
- Arrangement with an ME faculty member (or a faculty member from another department who is approved by the BME Undergraduate Program Director) who agrees to serve as the honors advisor, plus a second faculty member who will read and approve the thesis. The honors advisor must be a member of the Academic Council in the School of Engineering.

Application: Applications are subject to the review and final approval by the BME Undergraduate Program Director. Applicants and thesis advisors will receive written notification when a decision has been made. Submit application documents by the autumn quarter deadline to the Student Services Office, building 530, room 125. An application consists of

- One page written statement describing the research topic
- Unofficial Stanford transcript
- Signature of thesis advisor and thesis reader agreeing to serve on the committee

Deadline: No later than the second week of the autumn quarter of the senior year

In order to graduate with Honors:

- Declare ENGR-BSH (Honors) program in Axxess
- Maintain 3.5 GPA
- Submit a completed thesis draft to the advisor and reader by April 1
- Present the thesis synopsis at the Mechanical Engineering Poster Session held in April (usually the 3rd week)
- Further revisions and a final endorsement by the advisor and reader are to be completed by May 15th, when two bound copies are to be submitted to the Mechanical Engineering Student Services Office

BIOMEDICAL COMPUTATION

The Biomedical Computation program is pleased to offer an honors option for qualified students, resulting in a B.S. with Honors degree in Engineering (ENGR-BSH, Biomedical Computation). An honors project is meant to be a substantial research project during the later part of a student's undergraduate career, culminating in a final written and oral presentation describing the student's project and its significance. There is no limit to the number of majors that can graduate with honors; any BMC major who is interested and meets the qualifications will be considered.

1. Students apply by submitting a 1-2 page proposal describing the problem the student has chosen to investigate, its significance, and the student's research plan. This plan must be endorsed by the student's research and academic advisors, one of whom must be a member of the Academic Council. In making its decision, the department will evaluate the overall scope and significance of the student's proposed work.
2. Students must maintain a 3.5 GPA.
3. Students must complete three quarters of research. All three quarters must be on the same project with the same advisor. A summer quarter will count as one quarter of research. (Ideally, funding should not be obtained through summer research college sources, but rather through the UAR's Student Grants Program (<http://studentgrants.stanford.edu>). In no case can the same work be double-paid by two sources.)
4. Students must complete a substantial write-up of his or her research in the format of a publishable research paper. This research paper is expected to be approximately 15-20 pages and must be approved by the student's research advisor and by a second reader.
5. As the culmination of the honors project, each student will present his or her results in a public forum. This can either be in the honors presentation venue of the home department of the student's advisor, or in a suitable alternate venue.

Differences between BS and BSH Degree Work:

All BMC majors are currently required to complete two quarters of research and an associated WIM write-up. The honors option is intended for students who want to set a higher bar for their research and final project: Projects will be more rigorously screened prior to approval, a longer duration of research is required, and the final write-up and presentation are expected to be more in-depth. Additionally, there is a GPA threshold for achieving honors.

CHEMICAL ENGINEERING

This program offers an opportunity for undergraduate majors with a GPA of 3.5 or higher to undertake research at an advanced level with a faculty mentor, graduate students, and other undergraduates. This three-quarter sequential program involves (1) submission of a research proposal for faculty review, (2) appropriate faculty approvals, (3) enrollment in CHEMENG 190H and concurrent enrollment in the undergraduate honors seminar CHEMENG 191H, (4) in-depth research over a minimum of three quarters, (5) completion of a faculty-approved thesis, and (6) participation in the Chemical Engineering Honors Symposium held annually during the Mason Lecture Series, Spring Quarter. The last requirement may also be fulfilled through an alternative, public, oral presentation with the approval of the department chair. Work should begin a minimum of four quarters prior to graduation.

Chemical engineering majors who wish to be considered for the honors program should see departmental student services in Shriram Center, room 129, no later than the beginning of Winter Quarter of their junior year for more information about the application process, for a research proposal template, and for other assistance. An application must be submitted by March 4, 2015 (Winter Quarter of the junior year), and must include a proposal describing the research project, a transcript of courses taken at Stanford, and endorsement by both the student's research thesis adviser and a faculty reader. The research adviser or the reader or, alternatively, a faculty sponsor, must be a faculty member in the Department of Chemical Engineering. A faculty review committee will select the successful candidates. To qualify for departmental recommendation for the degree of Bachelor of Science in Chemical Engineering with Honors, degree students must:

1. Maintain an overall GPA of 3.5 or higher as calculated on the unofficial transcript.
2. Complete at least three quarters of research with a minimum of 9 units of CHEMENG 190H for a letter grade. All quarters must focus on the same topic. Maintain the same faculty advisor and faculty reader throughout, if feasible.
3. Enroll in CHEMENG 191H, Undergraduate Honors Seminar, concurrently with each quarter in 190H (Undergraduate Honors Research in Chemical Engineering).
4. Participate with a poster and oral presentation of thesis work at the Chemical Engineering Honors Poster Session held during the Mason Lectures week, Spring Quarter, or, at the Undergraduate Program Committee's discretion, at a comparable public event. Submit at the same time to student services one copy of the poster in electronic format.

5. Submit final drafts of a thesis simultaneously to both the advisor and the reader and, if appropriate, to the Chemical Engineering faculty sponsor, no later than April 6, 2015 (or the first school day of the second week of the quarter in which the degree is to be conferred).
6. Complete all work and thesis revisions and obtain indicated faculty approvals on the Certificate of Final Reading of Thesis forms by the end of the last full week of April (4/24/2015), or the first month of the graduation quarter.
7. Submit to Chemical Engineering Student Services five (5) final copies of the honors thesis as approved by the appropriate faculty by April 30, 2015. Include in each an original, completed, faculty signature sheet immediately following the title page. The department will submit one copy to the School of Engineering's Office of Student Affairs.
8. Submit to student services one copy of the honors thesis in electronic format at the same time as the final hard copies, or not later than April 30, 2015.

All requirements for the honors program are in addition to the normal undergraduate program requirements.

CIVIL ENGINEERING

Qualified engineering students can receive a B.S. with Honors in Civil Engineering by undertaking a more intensive course of study that includes an in-depth research project. To apply, you must find a faculty member in the CEE department who will serve as supervisor for your undergraduate honors thesis; the two of you must agree upon a topic for the thesis project.

In the fourth quarter before graduation (typically, spring quarter of junior year), you must submit to the CEE Student Services office for approval a written proposal describing the research to be undertaken. At the time of submittal you must have a GPA of at least 3.3 for coursework taken at Stanford, and this GPA must be maintained until graduation. You must complete a written thesis of high quality, obtaining input from the School of Engineering Writing Program via ENGR 202S or its equivalent. Up to 10 units of CEE 199H may be taken to support the research efforts. The completed thesis must be submitted to the thesis advisor for review by the end of the 4th week of the student's graduation quarter (e.g. April 25, 2014 for students graduating in spring 2014). Your advisor must approve and sign off on your written thesis. In addition to a written thesis, you are strongly encouraged to present your research results in a seminar. Two copies of the signed thesis must be provided to the CEE Student Services office by the end of the 9th week of the student's graduation quarter (e.g. May 30, 2014 for students graduating in spring 2014).

COMPUTER SCIENCE

Selected computer science undergraduates whose academic records and personal initiative indicate that they have the necessary skills to undertake high-quality research in computer science may apply to the honors program. Applicants must be majoring in Computer Science, must have a GPA of at least 3.6 in courses that count toward the major, and must achieve senior standing (135 or more units) by the end of the academic year in which they apply. Coterminal MS students are eligible to apply as long as they have not already received their undergraduate degrees. Beyond these requirements, students who apply for the honors program must also find a faculty member who agrees to serve as the thesis advisor for the project. Thesis advisors must be members of Stanford's Academic Council.

Students who meet the eligibility requirements and wish to be considered for the honors program must submit a written application to the Computer Science undergraduate program office by May 1 of the year preceding the honors work. The application must include a letter describing the research project, a letter of endorsement from the faculty sponsor, and a transcript of courses taken at Stanford. Each year, a faculty review committee will select the successful candidates for honors from the pool of qualified applicants.

In order to receive departmental honors, students admitted to the honors program must do the following, in addition to satisfying the standard requirements for the undergraduate degree:

1. Complete at least 9 units of CS191 or 191W under the direction of their project sponsor.
2. Attend a weekly honors seminar in winter quarter.
3. Complete an honors thesis deemed acceptable by a committee consisting of the thesis advisor and at least one additional faculty member.
4. Present the thesis at a public colloquium sponsored by the department.
5. **Maintain the 3.6 GPA required for admission to the honors program.**

ELECTRICAL ENGINEERING

The Electrical Engineering Department offers a program leading to a Bachelor of Science in Electrical Engineering with Honors. This program offers a unique opportunity for qualified undergraduate majors to conduct independent study and research at an advanced level with a faculty mentor, graduate students, and fellow undergraduates. To qualify, students must complete following requirements:

1. Submit an application, including the thesis proposal, by autumn quarter of senior year signed by the thesis advisor and second reader (one must be a member of the Electrical Engineering faculty).
2. Maintain a grade point average of at least 3.5 in Electrical Engineering courses.
3. Complete at least 10 units of EE 191 or EE 191W with thesis advisor for a letter grade. EE 191 units do not count toward the required 60 units, with the exception of EE 191W if approved to satisfy WIM.
4. Submit one final copy of the honors thesis approved by the advisor and second reader to the EE Degree Progress Officer by May 15.
5. Attend poster and oral presentation held at the end of spring quarter or present in another suitable forum approved by the faculty adviser.

ENGINEERING PHYSICS

Honors Criteria:

- Minimum overall GPA of 3.5.
- Independent research conducted at an advanced level with a faculty research advisor and documented in an honors thesis.

The honors candidate must identify a faculty member who will serve as his or her honors research advisor and a second reader who will be asked to read the thesis and give feedback before endorsing the thesis. One of the two must be a member of the Academic Council and in the School of Engineering.

Application Deadline: No later than October 15 in the autumn quarter of the senior year. The application documents should be submitted to the Student Services Officer and consist of three items:

1. One-page description of the research topic
2. Application form signed by the honors thesis advisor
3. Unofficial Stanford transcript

Applications are reviewed by a subcommittee of the faculty advisors for Engineering Physics majors. Applicants and thesis advisors will receive written notification when the application is approved.

Requirements and Timeline for Honors Degree in Engineering Physics:

1. Declare the honors program in Axess (ENGR-BSH, Subplan: Engineering Physics)

2. Obtain application form from the Student Services Officer.
3. Apply to honors program by October 15 in the autumn quarter of the senior year.
4. Maintain an overall GPA of at least 3.5.
5. Optional: Under direction of the thesis advisor, students may enroll for research units in ENGR 199(W) or in departmental courses such as ME 191(H).
6. Submit a completed thesis draft to the research advisor and second reader by April 15.
7. Present the thesis work in an oral presentation or poster session in an appropriate forum (e.g., an event that showcases undergraduate research and is organized by the department of the advisor, the school of the advisor, or the university).
8. Incorporate feedback, which the advisor and second reader should provide by April 30, and obtain final endorsement signatures from the thesis advisor and second reader by May 15.
9. Submit two signed, single-sided copies and an electronic version to the Student Services Officer by May 15.

ENVIRONMENTAL ENGINEERING

Qualified engineering students can receive a B.S. with Honors in Environmental Engineering by undertaking a more intensive course of study that includes an in-depth research project. To apply, you must find a faculty member in the CEE department who will serve as supervisor for your undergraduate honors thesis; the two of you must agree upon a topic for the thesis project.

In the fourth quarter before graduation (typically, spring quarter of junior year), you must submit to the CEE Student Services office for approval a written proposal describing the research to be undertaken. At the time of submittal you must have a GPA of at least 3.3 for coursework taken at Stanford, and this GPA must be maintained until graduation. You must complete a written thesis of high quality, obtaining input from the School of Engineering Writing Program via ENGR 202S or its equivalent. Up to 10 units of CEE 199H may be taken to support the research efforts. The completed thesis must be submitted to the thesis advisor for review by the end of the 4th week of the student's graduation quarter (April 24, 2015 for students graduating spring 2015). Your advisor must approve and sign off on your written thesis. In addition to a written thesis, you are strongly encouraged to present your research results in a seminar. Two copies of the signed thesis must be provided to the CEE Student Services office by the end of the 9th week of the student's graduation quarter (May 29, 2015 for students graduating spring 2015).

INDIVIDUALLY DESIGNED MAJOR IN ENGINEERING

Qualified IDMEN students may pursue a Bachelor's degree with Honors (IDMEN_BSH) following these general guidelines and consulting with advisors to set a topic and any further parameters regarding directed reading or research, special honors seminars, and the format of the honors work:

1. The student must submit a letter applying for the Honors option endorsed by the student's primary advisor and honors advisor; the letter should be submitted to the Office of Student Affairs in 135 Huang.
2. The IDMEN honors advisor may require coursework beyond what is required for the BS without honors.
3. The student must maintain a GPA of at least 3.5.
4. The student must complete an honors thesis or project. The manner of evaluating the work will be set by the honors advisor and a second reader, one of whom must be a member of the Academic Council in the School of Engineering. The deadline to submit the thesis or project will be decided by the honors or program advisor, but should be set by mid-May at latest.
5. The student must present the work in an appropriate forum, e.g., in the same session as honors theses are presented in the department of the advisor.
6. A copy of the signed (approved) thesis or project must be submitted to the Office of Student Affairs by the end of the second week of May (May 15 for those graduating in spring 2015).

MECHANICAL ENGINEERING

The Department of Mechanical Engineering offers a program leading to a Bachelor of Science in Mechanical Engineering with Honors. This program provides a unique opportunity for qualified mechanical engineering majors to conduct independent study and research at an advanced level with a faculty mentor.

Honors Criteria:

- GPA of 3.5 or higher in the major
- Arrangement with an ME faculty member who agrees to serve as the thesis advisor. The advisor must be a member of the academic council.
- Application Deadline:
No later than the second week of the autumn quarter of the senior year.

Application:

- One page written statement describing the research topic and signed advisor form (see ME Student Services for form)
- Unofficial Stanford transcript (from Axxess)
- Signature of thesis advisor
- Submit all of the above to the Student Services Office, Building 530, room 125

Applications are subject to the review and final approval by the Undergraduate Curriculum Committee. Applicants and thesis advisors will receive written notification when a decision has been made.

In order to receive departmental honors:

- Declare the honors program in Axxess
- Maintain the 3.5 GPA required for admissions to the honors program
- (Optional): Under direction of the thesis advisor, complete at least 9 units of ME191H (Honors Thesis) during the senior year.
- Submit a completed thesis draft to the advisor and Student Services Office by April 1
- Present the thesis synopsis at the Mechanical Engineering Poster Session held in April (usually the 3rd week)

Further revisions and a final endorsement by the advisor are to be completed by May 1, when two bound copies are to be submitted to the Mechanical Engineering Services Office

7. OTHER DEGREE PROGRAMS

In addition to the Bachelor of Science degree, the School of Engineering offers a variety of additional degree options.

ALTERNATIVE BACHELOR'S DEGREES

Bachelor of Arts and Sciences

The Bachelor of Arts and Sciences (B.A.S.) is a baccalaureate degree available to those students who complete the requirements for a major leading to the B.S. degree and for a major leading to the A.B. degree, with no overlapping courses allowed. It is particularly appropriate for engineering students with a strong interest in the humanities and social sciences and allows a student to take full advantage of Stanford's eminence in the liberal arts. Note that this degree requires a minimum of 180 units as contrasted with a Dual A.B. and B.S. Degree Program, which requires 225 units. For further information see the *Stanford Bulletin*.

Multiple Bachelor of Science Majors

It is possible to receive a single B.S. degree with designations in two separate majors. The second major may or may not be in engineering. For example, students completing separate depth requirements for two different engineering majors may receive a degree designating both majors, with no overlapping courses in depth requirements. Alternatively, a **Secondary Major** is one degree with a note on your transcript that requirements for a second major were completed. For further information see the *Stanford Bulletin*.

COTERMINAL DEGREE PROGRAMS

Students may work simultaneously toward a bachelor's and a master's degree. The degrees may be granted simultaneously or at the conclusion of different quarters, though the bachelor's degree cannot be awarded after the master's degree has been granted. The two degrees do not have to be from the same department; for example, a B.S. in Mechanical Engineering and a M.S. in Aeronautics and Astronautics is possible.

The University minimum requirements for the coterminal bachelor's/master's program are 180 units for the bachelor's degree plus 45 (or higher departmental requirement, as determined by

each graduate department) *unduplicated* units for the master’s degree. A student may apply for the coterminal B.S. and M.S. program after completing 120 units toward graduation and no later than the end of their eleventh quarter. Students should apply directly to the department in which they wish to receive the M.S. degree. Most departments require the Graduate Records Examination (GRE); applications can be obtained at Undergraduate Advising and Research in Sweet Hall. Forms must be submitted, along with an up-to-date transcript, to the department in which the student wishes to obtain the M.S. degree. It is recommended that an applicant check with the proposed graduate department to learn the optimal timing for submitting an application.

FIGURE 7-1. DEPARTMENTAL INFORMATION FOR CO TERM PROGRAMS

Dept/Program	Application Deadlines	Contact	Informational Website
Aeronautics & Astronautics	3 deadlines; application at Durand 250	AA Student Services Manager	aa.stanford.edu
Bioengineering	Friday, November 1, 2014	Olgalydia Urbano Winegar bioengineering@stanford.edu	bioengineering.stanford.edu
Biomechanical Engineering	10/7/14 for Win 14-15 01/20/15 for Spr 14-15 04/28/15 for Aut 15-16	Indrani Stangl indrani@stanford.edu	meinquiry@stanford.edu
Chemical Engineering	11/05/14 for Win 14-15 02/19/15 for Spr 14-15 05/12/14 for Aut 14-15	Jeanne Cosby cosby@stanford.edu	cheme.stanford.edu
Civil and Environmental Engineering	2 nd Friday of Winter quarter	Jill Filice Jill.filice@stanford.edu	cee.stanford.edu
Computational & Mathematical Engineering	10/15/14 for Wtr 14-15 1/15/15 for Spr 14-15 1/6/15 for early Autumn 4/15/15 for late Autumn	Indira Choudhury	http://lcm.e.stanford.edu
Computer Science	9/27/13 for Wtr 13-14 1/10/14 for Spr 13-14 12/10/13 - early Aut 14-15 3/28/14 - late Aut 14-15	Jay Subramanian	http://cs.stanford.edu/education/admissions
Electrical Engineering	7/15/14 for Aut 14-15 10/14/14 for Win 14-15 1/27/15 for Spr 14-15 5/5/15 for Sum 14-15 5/5/15 for Aut 15-16	Emily Wang	http://ee.stanford.edu/admissions
Engineering: General		Sally Gressens	See <i>Stanford Bulletin</i> , SoE section, <i>Masters in Engineering</i>
Management Science & Engineering	10/07/14 for Win 14-15 1/13/15 for Spr 14-15	Juanita Winkleman Lori Cottle	http://www.stanford.edu/dept/MSandE/cgi-bin/admissions/admitcoterm.php
Materials Science & Engineering	4 th Friday of each quarter	Fi Verplanke verplanke@stanford.edu	http://mse.stanford.edu matsciengr@stanford.edu
Mechanical Engineering	10/7/14 for Win 14-15 01/20/15 for Spr 14-15 04/28/15 for Aut 15-16	Indrani Stangl indrani@stanford.edu	meinquiry@stanford.edu

8. SPECIAL PROGRAMS AND ORGANIZATIONS

Chapter Contents:

EDP resources

Technical Communications Program offerings

Stanford Technology Ventures Program (STVP)

Overseas Study: Countries and course offerings abroad

Research Education for Undergraduates (REU)

Student Engineering Societies

ENGINEERING DIVERSITY PROGRAMS (EDP)

The School of Engineering believes strongly in encouraging all students to succeed in engineering. Indeed, one of the great strengths of any educational system lies in having a student body that is both highly qualified and diverse. Because of its strong belief in the value of diversity, the School especially encourages underrepresented racial and ethnic minorities, first-generation low-income college students, disabled students, and others whose backgrounds and experiences provide additional dimensions that enhance learning and equity, to utilize the Engineering Diversity Program services and resources.

To underscore its dual commitment to excellence and the value of diversity, the School of Engineering provides a wide range of resources and services through the Engineering Diversity Programs (EDP), which are available to all Stanford students:

- Academic and general advising for undergraduate and graduate students, which includes academic skills development, creating four-year undergraduate plans, Ph.D. academic and professional development support, identifying summer internships, and creating self-directed study groups.
- Accelerated Calculus for Engineers (ACE), an introductory mathematics series for additional credit units and added rigor.
- Outreach to and recruitment of graduate EDP students.
- Fellowships, teaching and research assistantships for Ph.D. EDP students and selected Master's students.
- Support and sponsorship of Society of Women Engineers (SWE), Society of Black Engineers and Scientists (SBSE), American Indian Science and Engineering Society (AISES), and Stanford Society of Chicano/Latino Scientists and Engineers (SSCLES).

- Stanford Summer Engineering Academy (SSEA), a one-month residential program for entering freshmen that allows them to explore various engineering and science fields. Taught by faculty, students are involved in hands-on and minds-on learning.
- Recruiting students for corporate EDP scholarships.
- Tutoring is offered in collaboration with the Center for Teaching and Learning. See the SoE website <http://engineering.stanford.edu/portals/student/academic-support-and-resources/tutoring> for more information.
- Engineering and Science Opportunity Job Fair, and diversity job and internship search support, which supplements that offered by the Career Development Center.
- Graduate Environmental Support Seminar, Graduate Seminar on Teaching and Advising Methods, Graduate EDP Orientation, and Graduate Diversity Admit Weekend.
- Graduate and Professional Advisor Program, which matches interested undergraduate students with graduate students, faculty, alumni, deans, and corporate representatives in specific engineering fields.

TECHNICAL COMMUNICATIONS PROGRAM

The Technical Communications Program offers a variety of courses and tutorial services designed to help engineering students improve their writing and speaking skills and to prepare them to communicate effectively when they become professionals.

Each quarter the program offers several courses in technical/professional writing and public speaking/presentation. These courses are specially designed for engineering students and stress regular individual tutorial instruction.

- **ENGR 100—Teaching Public Speaking. (3 units).** This course is for E103 graduates who are interested in becoming involved in the TCP's Public Speaking courses. Students will continue to refine their own communication skills while becoming actively involved in the E103 course. Weekly readings and discussions will expand the students' understanding of issues in both communication and teaching.
- **ENGR 103—Public Speaking (3 units).** Introduces students to the full range of speaking activities, from impromptu talks to carefully rehearsed formal presentations. Students will learn to create and deliver a variety of speeches, with special emphasis given to delivering professional material to interdisciplinary audiences. This practical course helps students develop confidence in their speaking

ability through weekly practice in class and individual tutorials. Autumn, Winter, Spring

- **ENGR 202W—Technical Writing** (3 units). How to write clear, concise, and well-ordered technical prose. Drafting strategies and principles of editing for structure and style. Applications to a variety of genres in engineering and science. Graduate level; undergraduates admitted with consent of instructor. Autumn, Winter, Spring.
- **ENGR 202S—Writing: Special Projects** (1 unit). Writing tutorial for students working on non-course related materials including theses, journal articles, and conference papers. Weekly individual meetings. May be repeated for credit. Autumn, Winter, Spring.

The Technical Communications Program also provides **non-credit writing and public speaking tutorials**. Students can meet with a writing tutor who will help them draft and revise such documents as statements of purpose, research statements, cv's/resumes, and cover letters. Students can meet with a speech tutor who will help them plan presentations, design visual aids, and improve delivery. NOTE: These non-credit tutorials are not an editing service and are intended for short-term assistance. For extended tutorial support, students should register for one of the formal courses.

For further information on TCP see <http://soe.stanford.edu/tcp/>

STANFORD TECHNOLOGY VENTURES PROGRAM

The Stanford Technology Ventures Program (STVP) is the entrepreneurship center within the Stanford University School of Engineering, hosted by the department of Management Science and Engineering. STVP's mission is to build a world-class center dedicated to accelerating high technology entrepreneurship research and education for engineers and scientists worldwide. STVP's believes that engineers and scientists need entrepreneurial skills to be successful at all levels within organizations, and prepares students for leadership positions in industry, universities, and society. STVP consists of courses, conferences, online resources, and scholarly research on high technology entrepreneurship. More information can be found at the program's web site at <http://stvp.stanford.edu>.

Mayfield Fellows Program

The Mayfield Fellows Program (MFP) is a key component of the Stanford Technology Ventures Program. MFP provides juniors, seniors and co-terminal masters students in engineering and the sciences with an intensive nine-month work/study program focusing on entrepreneurship. This includes all three courses in the "Management of Technology Ventures" series (ENGR140A,

ENGR140B, and ENGR140C). These courses use a multidisciplinary approach to teaching entrepreneurship, including small seminar-style classes, a paid summer internship at a start-up company, and off-site meetings with leaders in the entrepreneurial community. In addition, each student is matched with three mentors including their summer employer, a venture capitalist, and a MFP alumnus.

New Mayfield fellows apply in early February, are announced in March and the program begins in April, running through December of each year (spring, summer, and autumn quarters). A dozen outstanding students are admitted each year. Additional information is available at the program's web site at <http://stvp.stanford.edu/teaching/mfp/program.html>

TUTORING & ACADEMIC SUPPORT

In addition to help from professors' and TAs' office hours, various kinds of **tutoring and academic skills coaching** are available for all students. Tutoring and coaching are used by students in all years and at all levels of understanding. The website describes not only peer tutoring but also Oral Communication tutoring, writing tutoring, and Academic Coaching:

<https://undergrad.stanford.edu/tutoring-support>

You can also check this site for opportunities to become a tutor – engineering tutors are in high demand!

ENGINEERS AND OVERSEAS STUDIES

“The (study abroad) perspective has been, for me, the most interesting, life-changing, and valuable effect of studying abroad. It is also something that cannot be easily achieved without studying abroad—the way that the abroad experience immerses you in a rich and realistic life, though temporary, provides you with an experience that cannot be achieved later as a traveler.” Paris Alum

GLOBAL ENGINEERING PROGRAMS

International programs aim to enhance engineering education by providing students an opportunity to learn about global emerging economies, to build professional networks, and to gain real world work experience in a culturally diverse and international environment.

China Internship Program: Each summer, the School of Engineering coordinates an internship program in which students work in Chinese (domestic) and multinational companies with offices in China. The program is open to Stanford engineering students at the undergraduate, coterm,

masters, and PhD levels. More than 20 companies have hosted our interns in Beijing, Shanghai and Hangzhou and more than 80 students have participated in the three-month program since 2008. Undergraduates who will be declared in engineering at the time of the internship are welcome to apply. Check the website given below for dates of information sessions, deadlines, and other details.

I had the most incredible summer experience in Beijing. I am so grateful for the connections and friendships I made while in China. This experience has...helped me realize that I would like to use my background in both writing and biomechanical engineering to influence both policy and infrastructure change in developing countries." – Beijing Alum

Service Projects: The School of Engineering is also supporting service learning programs in which Stanford engineering students can work in China for part of the summer on projects in rural villages. For more information please visit our website:

<http://engineering.stanford.edu/portals/student/jobs-and-internships/global-engineering-programs>

BING OVERSEAS STUDIES PROGRAM (BOSP)

For many years the School of Engineering and the Bing Overseas Studies Program have collaborated to provide outstanding opportunities for engineering majors to study, work, and experience life in other countries. Careers in engineering frequently have an international component—whether through working as a consultant in another culture, transferring for a period of time to another country, or establishing an enterprise and developing contacts in other areas of the world. Achieving cultural literacy in another country provokes reflection on the differences and similarities among societies and prepares students to work in an international context.

With careful planning, most engineering students can fit study at one of Stanford's overseas centers into their academic plans. BOSP encourages students to talk with their advisors early on, as early as freshman year, about planning for one or more quarter(s) abroad. By starting early, students can strategically plan for required engineering courses and language acquisition and then be able to study and work abroad while making progress toward their Stanford degrees. Some programs require minimal language study prior to enrollment. Most programs include courses that satisfy two or more University General Education Requirements (GERs or WAYs) so prospective engineering majors can plan to fulfill one or two requirements abroad.

Starting in 2014-15, students studying at most Stanford overseas centers may take selected advanced engineering courses offered in an online format by the Stanford Center for Professional Development (SCPD). A student may take a maximum of one of these courses per quarter. An online course that satisfies the Technology in Society requirement may also be offered starting in Winter 2015. In addition, some Stanford overseas centers offer selected engineering fundamentals courses as tutored video courses.

Engineering faculty teach abroad as Faculty-in-Residence at BOSP's overseas centers.

2014-15

Steve Cooper	Computer Science	Spring	Beijing
Margaret Brandeau	MS&E	Winter	Cape Town

2015-16

Clyde Tatum	Civil & Environmental	Autumn	Berlin
Allison Okamura	Mechanical Engineering	Spring	Kyoto
Adrian Lew	Mechanical Engineering	Winter	Madrid

For a list of current and future faculty-in-residence, please visit

<https://undergrad.stanford.edu/programs/bosp/teach/faculty-residence>

The Associate Dean for Student Affairs in Engineering as well as advisors in Undergraduate Advising and Research (UAR), and Program Advisors and Student Advisors in the Bing Overseas Studies Program can help students strategize how to integrate coursework taken overseas into their overall academic planning.

Information about Stanford's programs, including courses offered, is available online at **<http://bosp.stanford.edu>**. Students are also encouraged to stop by the BOSP office on the ground floor of Sweet Hall. The following program information highlights opportunities that might be of special interest to engineers.

AUSTRALIA

For me, one of the greatest parts of my study abroad experience was the opportunity to interact with brilliant, interesting, and fun professors and graduate students from another university. If I had known how awesome the people would be in Australia, I would have been even more sold on the program than I was already.

–BOSP Australia Alum

During Autumn Quarter, students in the BOSP Australia program focus on topics in Australian coastal studies at various locations in Queensland, including the Great Barrier Reef. This

program has been established in collaboration with the University of Queensland, School of Biological Sciences. Up to 48 students are enrolled in four required academic modules: Coral Reef Ecosystems, Coastal Forest Ecosystems, Freshwater Systems, and Australian Studies. Civil and Environmental Engineering has approved credit for some of these courses. In addition, students complete Targeted Research Projects on selected topics under the supervision of University of Queensland instructors. This opportunity to do hands-on research will greatly enhance students' research skills and their appreciation of issues Australia faces as it deals with ecotourism and protection of the Great Barrier Reef. SCPD courses are NOT available for engineering students in Australia.

BEIJING

Peking University (PKU) hosts BOSP's program in Beijing, China during Autumn and Spring Quarters. The program offers a variety of courses in the humanities and social sciences, including many that satisfy GERs and WAYs. Beijing classes are taught in English by Peking University faculty, as well as by Stanford Faculty-in-Residence. Many PKU professors hold graduate degrees from US institutions. Although courses are taught primarily in English, students in the Beijing program are required to study Chinese language while in Beijing. Prior Chinese language study is not required for Autumn Quarter participation, when students can enroll in first-quarter Chinese. The minimum requirement for enrollment in Spring Quarter is two quarters of college-level Mandarin (CHINLANG 2). Selected SCPD courses may be available for engineering students in Beijing. For additional details, please see

<https://undergrad.stanford.edu/programs/bosp/explore/search-courses>

BERLIN

My internship experience really complemented what I'd learned in my engineering classes. In fact, I felt that I received two educations for the price of one. I did a long internship, and it was worth it. Doing a long internship means you can learn more, show more effort, and the company gets a better feel for you. They might even hire you back. I'm a very obvious example of staying longer. I'm back in Germany now working for the same company as a permanent employee.

—BOSP Berlin Alum

The Berlin Center exposes students to the rich culture and complex history of the city and is open for study in Autumn, Winter, and Spring Quarters. Students who study in Berlin for one or more quarters and have completed one year of German language (GERLANG 3) are eligible to participate in a full-time Krupp Internship in any succeeding quarter(s). Since 1982 the Stanford Program in Berlin, with support from the Krupp Foundation (Alfried Krupp von Bohlen und Halbach-Stiftung: <http://www.krupp-stiftung.de>), has placed over 1100 Stanford students, well over half of whom are engineers, in paid internships throughout Germany. Internships are available in virtually all fields of engineering. In close cooperation with the applicants, the onsite

Internship Coordinator works to place students in internships closely related to their academic and career interests and their technical and language skills. Internship placements are in private companies and public institutions all over Germany, not only in Berlin. The program guarantees €1000 for a full working month, which covers all living expenses. Internships last from three to six months.

Students without previous German language experience can enroll in beginning intensive German in Berlin in Autumn or Winter Quarter, or they can take a minimum of one quarter of German prior to arrival in Spring Quarter. The equivalent of three quarters of German is required before beginning a Krupp Internship. This is the minimum; some hosts might require a higher level of proficiency. Internships tend to be more rewarding for those engineering students – advanced junior, senior, and co-term – who have already taken a number of engineering courses; product design students must have a portfolio of work proofs. Past internship hosts have included: Bosch, BMW, 3M Germany, Siemens, Volkswagen, Yahoo! Deutschland, and Fraunhofer Institutes for Mechanical Engineers and computer scientists; Bayer, Sanofi-Aventis Deutschland GmbH, Max-Delbrück Center for Molecular Medicine, and Max-Planck-Institutes for Chemical Engineers; Bosch, LuraTech, Sennheiser, and Siemens for Electrical Engineers; Hochtief, Corporation for Sustainable Building Technology (GFÖB/Arcadis Deutschland), Berlin Senat Department for Urban Development, and Fraunhofer Institutes for Architects and Civil Engineers; and Brandenburg Economic Development Board Potsdam, Continental Automotive, Greiner Ingenieurberatung, Rolls Royce Deutschland, and VCM Venture Capital Management for Management Science & Engineering students. After returning to campus students can work with the Department of German Studies to reflect on their internship experiences in writing and earn academic credit for doing so. See

<https://undergrad.stanford.edu/programs/bosp/explore/berlin/about-program/overview> and **<http://www.stanford.fu-berlin.de/>** for program details and internship profiles. Because all coursework at the Berlin Center satisfies German Studies departmental requirements for the major and minor, some engineering students who have studied in Berlin have even graduated with a German Studies minor or double major.

ENGR 40 and ENGR 50 are currently offered as tutored video courses. Beginning in 2014-15, engineering students can enroll in one SCPD course from a selected list. For additional details, please see **<https://undergrad.stanford.edu/programs/bosp/explore/search-courses>**.

CAPE TOWN

Now open in Winter, Spring and Summer Quarters, the BOSP program in Cape Town introduces students to the people, history, politics, and culture of post-apartheid South Africa, with an emphasis on initiatives undertaken and challenges faced by an emerging democracy. Service

learning, encouraged for all students, is core to the program enabling students to contribute to development efforts of the Center's NGO partners, activists and residents of Cape Town communities as they learn about them and their work. When integrated with critical reflection and concurrent coursework, these opportunities deepen learning about South Africa and the ethics and practice of service in such contexts and help ensure that the program and its participants positively impact citizens and communities of the Western Cape. Students may also elect to participate in the Program's Community-Based Partnership Research program and undertake investigations into information needs of the partners.

Engineering School students have participated in the Cape Town program consistently since it opened in 2010. Some of these students find that they can explore their major interests through service-learning activities that include: investigation of water quality and distribution policies; environmental analysis and activism; mathematics instruction, etc. Others use the service-learning program as a time to explore other interests outside their major. Beginning in 2014-15, engineering students can enroll in one SCPD course from a selected list. For additional details, please see <https://undergrad.stanford.edu/programs/bosp/explore/search-courses>

FLORENCE

It was the most integrated academic experience I've ever had; I truly felt like I was learning every moment of the day. My classes, almost all about modern Italy, dovetailed with each other, but also dealt with issues I was confronting every day in the newspapers, with my Italian "family," with Italian friends and in movies and music.

—BOSP Florence Alum

Home to important innovators such as Galileo, Leonardo da Vinci, and Brunelleschi, the city of Florence provides unique intellectual and visual resources for students in different fields. In particular, it offers engineering students unparalleled opportunities to study the techniques and the innovations of the Renaissance engineers that brought about great marvels such as Brunelleschi's Cupola. Qualified students can also elect to participate in academic internships in engineering, architecture, product design and related fields (to learn more please email fosca@stanford.firenze.it). The program is structured to integrate students as fully as possible into Italian culture through homestays, language partners, and volunteer work during the Autumn, Winter, and Spring Quarters. A minimum of one year of Italian (ITALLANG 3) is required. A version of ENGR 50 is currently offered all three quarters as tutored video with the support of an on-site engineering professor and his own on-campus counterpart. Beginning in 2014-15, engineering students can enroll in one SCPD course from a selected list. For additional

details, please see <https://undergrad.stanford.edu/programs/bosp/explore/search-courses>

KYOTO

My mentor was the only female engineer and she was terrific. She is still a source of inspiration to me, and we have kept in contact since. I learned more about Japanese companies by being there than you can ever learn in books . . . during everyday experiences like the morning group meeting to the relatively rare, like the group “off-site” sleepover party at a hot spring spa.

—Kyoto-SCTI Alum

The Stanford Program in Kyoto was founded in collaboration with the School of Engineering, and has since provided students of engineering the opportunity to fit language immersion and practical classroom experience into their busy schedules. The program is designed for students with intellectual interests in the structure and politics of advanced economic and technological systems, in Japan’s unique energy-environment situation, and in exploring aspects of contemporary Japanese society and its cultural underpinnings. For students with technical specialties, the program helps them understand the professional value of developing a linguistic and cultural competence that facilitates interaction with Japanese while simultaneously complementing their technical abilities. The program is open both Winter and Spring Quarters. In Spring Quarter, an electronic version of ENGR 261 is offered with the support of an on-site graduate student from Electrical Engineering and ENGR 40 is also offered as a tutored video course. Beginning in 2014-15, engineering students can enroll in one SCPD course from a selected list. For additional details, please see

<https://undergrad.stanford.edu/programs/bosp/explore/search-courses>

Minimum language requirements for Kyoto differ depending on whether a student chooses to complete the optional summer internship and whether an internship is technical or non-technical in nature. Students not intending to complete an internship or those interested in a technical internship must complete one quarter of five-unit JLCC (JAPANLNG 1) prior to Winter enrollment or two quarters of five-unit JLCC (JAPANLNG 2) prior to Spring quarter enrollment. Students participating in a technical internship must complete the third quarter of first year Japanese either on campus (JAPANLNG 3) or in Kyoto (OSPKYOTO 3K) prior to the summer internship. Students proposing internships in non-technical fields must complete four quarters of five-unit JLCC (JAPANLNG 21) prior to Winter quarter enrollment or five quarters prior to Spring quarter enrollment. The final quarter of the second-year sequence can be taken either on campus (JAPANLNG 23) or in Kyoto (OSPKYOTO 23K). Please note that the requirements for non-technical internships are currently under review.

The Internship Coordinator works to place all students in fully funded internships (accommodation and stipend provided) related to their academic and career interests. Student interns are expected to participate in the internship in Japan from late June for a 10-week period. Interns are placed in organizations of all sizes and structures, from multinationals such as Hitachi, NEC, Fujitsu and Kawasaki, to national leaders such as Rakuten, KVH, DeNA and Akebono Brake Corporation, through to entrepreneurial start-ups such as Appirits and NaviPlus. The program also strives to place students with highly specialized interests in appropriate organizations, with past placements including Keiko University Hospital, a family-run *taiko* drum shop, and an organic farm.

MADRID

The program in Madrid is open Autumn, Winter and Spring Quarters and has a language requirement of one year of Spanish (SPANLANG 3 or SPANLANG 2A). In addition to opportunities to explore Spain's history and culture through a variety of humanities, health and social science courses, the Madrid program offers engineering students with sufficient language fluency the possibility of enrolling in courses at the Universidad Politécnica, one of Spain's premier engineering universities. Its Industrial Engineering School is close to the Stanford Center and offers courses that are of interest to Stanford students. Students can also participate in academic internships as part of the course "Integration into Spanish Society." Beginning in 2014-15, engineering students can enroll in one SCPD course from a selected list. For additional details, please see <https://undergrad.stanford.edu/programs/bosp/explore/search-courses>

OXFORD

My academic work at Oxford reached a level of intensity that was difficult to attain at Stanford because the one on one tutorials forced me to focus my research interest into a coherent investigation of a single question. I have never been so excited to do research in my life because Oxford gave me a brilliant and energetic teacher that met with me individually for two to three hours per week. It was the first time that I ever felt like I had a part in the learning process because the classes were driven solely by my input and interest.

—BOSP Oxford Alum

The Stanford program in Oxford is offered in Autumn, Winter, and Spring Quarters, and each student takes a tutorial as a regular part of the program. As the characteristic pedagogical method for undergraduates at Oxford, the tutorial is a highly personalized, demanding, and rewarding form of instruction that involves weekly meetings between a student (or, occasionally, two students) and a member of the Oxford academic community. Tutorials on selected topics in engineering, including architecture and computer science, are sometimes possible. The BOSP

website has a list that students can review to see the range of tutorials. Beginning in 2014-15, engineering students can enroll in one SCPD course from a selected list. For additional details, please see <https://undergrad.stanford.edu/programs/bosp/explore/search-courses>

PARIS

Studying in Paris was incredible and I think impossible to completely understand unless experienced. Not only was having classes in French in a French university setting interesting, but it seemed like the entire city acted like a classroom. All academic, artistic, social, and cultural experiences are part of the program.

—BOSP Paris Alum

The Bing Overseas Studies Program, the School of Engineering, and the Department of French and Italian are working together to provide opportunities for engineering students studying in Paris. The Stanford Program in Paris is located in the Institut Supérieur d'Électronique de Paris (ISEP). ENGR 40 is offered as a tutored video course in Autumn and Spring and ENGR 50 in all three quarters. Students in these courses meet weekly for tutoring with a member of the ISEP or another engineering school faculty member. Beginning in 2014-15, engineering students can enroll in one SCPD course from a selected list. For additional details, please see <https://undergrad.stanford.edu/programs/bosp/explore/search-courses>

One year of college-level French (FRENLANG 3) is required and students with two years of college-level French will have access to additional engineering courses taught in French. Internship arrangements are continuously being expanded in France. One of the newest academic internship offerings involves participation in an Electronic Engineering Lab during the Autumn, Winter, or Spring, Quarters. To be eligible for this internship, students are expected to have some background in electronics or microelectronics. These new research internships are financed by French companies or hospitals and are excellent ways to pursue research in your field in Paris while getting to know French and international researchers at the ISEP, your host institution. They include research in the fields of image processing, robotics connection, radio digitalization, and object tracking. A second network of internships is based on students' specific interests and requests and can accommodate the diverse interests of engineering students. These require students spend two quarters in Paris, either Autumn and Winter or Winter and Spring. The first quarter is devoted to gauging students' interests and preparing for the experience, the second, to the internships themselves.

SANTIAGO

With ecosystems extending from the desert to the Antarctic, Chile incorporates a unique range of environments. Located in Santiago, the BOSP program is open Spring, Summer and Autumn

Quarters with the majority of its courses taught in Spanish. A thematic quarter with a focus in the areas of ecology and urban planning has been offered since Spring Quarter 2012-13. A Civil and Environmental Engineering approved course on Chilean energy management and policy is offered in Summer Quarter. Internships can be arranged with organizations concerned with renewable energies and seismic technology. Through the language-partner program, Stanford students interact with Chilean students, often engineering students, to develop their language skills. Students who stay for two quarters (Summer and Autumn Quarters), and have a high level of Spanish proficiency, can take courses, including engineering courses, at the two major local universities, the Universidad de Chile, and the Universidad Católica de Chile. The language requirement is one year of Spanish (SPANLANG 3 or SPANLANG 2A). Beginning in 2014-15, engineering students can enroll in one SCPD course from a selected list. For additional details, please see <https://undergrad.stanford.edu/programs/bosp/explore/search-courses>

OVERSEAS SEMINARS

For those students who want to get an initial taste of being overseas, BOSP offers Overseas Seminars. These seminars provide the opportunity for 12-15 students to participate in an intensive, three-week course taught by Stanford faculty. The seminars, offered for two units of Summer Quarter credit, focus on locally relevant topics and include travel within a particular region to supplement class work. Seminar locations for 2013-14 were in Brazil, Ecuador, England, France, Italy and the Netherlands. Each year, there will be a changing array of seminars offered in a variety of locations. For additional information please see <http://bosp.stanford.edu/seminars>.

OTHER BOSP PROGRAMS AND RESOURCES

In addition to the programs mentioned above, the Bing Overseas Studies Program also offers a Winter Quarter program in Istanbul and consortium programs in Barcelona (CASB), where students can take up to 3 science and engineering classes in Spanish/Catalan at Universitat Politècnica de Catalunya-UPC, and in Kyoto (KCJS). Keep in mind that in any quarter of study, Stanford Engineering faculty members may be faculty-in-residence at one of the BOSP programs, thus providing expanded opportunities for engineering students.

For students interested in information on non-Stanford programs, a BOSP staff member can advise you regarding the processes involved when studying in a non-Stanford program and applying for transfer credit.

Information about applications and deadlines can be found at <http://bosp.stanford.edu> as well as complete and up-to-date descriptions of BOSP opportunities and the range of academic options offered overseas.

For information on scholarships for study and research abroad or overseas internships and short-term work, see the “Summer Employment and Career Planning” section later in this handbook.

RESEARCH EXPERIENCE FOR UNDERGRADUATES

Engaging in independent research under the direction of a faculty member can be one of the most exciting and rewarding experiences of your undergraduate career. The Research Experience for Undergraduates (REU) program is designed to give undergraduates the chance to work with faculty and their research groups on advanced research projects. The program runs ten weeks, from June (beginning shortly after commencement) through August. The program is coordinated jointly by the Office of the Vice Provost for Undergraduate Education, the Office of Student Affairs in the School of Engineering, and the individual engineering departments.

Students who are accepted into the program will receive a summer stipend. On-campus housing and a meal plan may also be provided through the Summer Research College (SRC) but must be applied for separately. Whether well into your major or still testing the waters, all engineering students are strongly encouraged to consider taking advantage of what the REU program can offer. To find out more about the opportunities and how to apply, go to the School of Engineering website <http://engineering.stanford.edu/portals/student/research-experience-undergraduates>. The application deadline varies for every department; check your major department’s webpage for additional information and deadlines.

STUDENT ENGINEERING SOCIETIES

TAU BETA PI

Tau Beta Pi is the only engineering honor society that represents the entire engineering profession. It is the nation’s second oldest honor society and was founded at Lehigh University in 1885 to recognize students of exemplary character and distinguished scholarship. There are now active collegiate chapters at 249 US colleges and universities, active alumni chapters in 16 districts across the United States, and a total initiated membership of 545,000.

The California Gamma chapter of Tau Beta Pi at Stanford offers valuable engineering resources. Tau Beta Pi provides peer tutoring services across the engineering disciplines to build understanding and interest in science, mathematics, and engineering. Tau Beta Pi also runs a

variety of engineering career events, service projects, and social activities for the undergraduate engineering student community. These activities include helping to coordinate activities for New Student Orientation, leading engineering events for Admit Weekend, selecting the recipient of the Stanford Tau Beta Pi Award for Excellence in Undergraduate Teaching, organizing off-campus company tours, and holding quarterly socials for engineering students.

To be officially elected as a member of Tau Beta Pi, you must be a declared engineering major and have placed within the top one-eighth of your class as a junior or the top one-fifth of your class as a senior. Invitations are sent to elected students twice a year, once in the fall and once in the winter. Invited candidates must fulfill the candidacy requirements of the California Gamma Chapter through participation in service and fellowship activities. While it is considered an honor to be elected into Tau Beta Pi, one does not need to be an official member to participate in the activities organized by the society. For more information, please visit our website at <http://tbp.stanford.edu> or email the chapter president, Tim Schnabel (tims2015@stanford.edu).

INSTITUTE OF ELECTRICAL AND ELECTRONICS ENGINEERS

The Stanford Institute of Electrical and Electronics Engineers (IEEE, pronounced “eye-triple-E”) is the CS- and EE-department-backed academic, professional and networking society for Computer Science and Electrical Engineering students. IEEE is a professional association of over 400,000 engineers in more than 160 countries focused on developing technical standards, affecting technology policy, promoting career development, and creating communities of networked technical professionals. At Stanford, the organization provides access to peers, more advanced students, professors, and industry engineers to foster a more complete engineering education experience in and out of the classroom. Stanford IEEE sponsors programming and electronic design competitions, community service, mentorship, research, and scholarship grants. Please visit the IEEE website at <http://ieee.stanford.edu> for more information.

BUSINESS ASSOCIATION OF STANFORD ENGINEERING STUDENTS (BASES)

BASES is the primary extra-curricular vehicle for students who are interested in technology and entrepreneurship. BASES has evolved to include undergraduate and graduate students, along with faculty members from all schools at Stanford, including Engineering, Business, Law, Medicine, and the Humanities and Sciences. It hosts a collection of programs on campus, including two annual business plan competitions with prizes up to \$100K (the E-Challenge and Social E-Challenge), a weekly lecture series called Entrepreneurial Thought Leaders Seminar with talks by technology and business leaders, start-up job fairs, and various community initiatives. For more information about BASES, visit their website at <http://bases.stanford.edu/getinvolved/>.

SCHOOL OF ENGINEERING STUDENT DIVERSITY GROUPS

- American Indian Science and Engineering Society (AISES)
- Society of Black Scientists and Engineers (SBSE)
- Society of Women Engineers (SWE)
- Stanford Society of Chicano/Latino Engineers and Scientists (SSCLES)

STANFORD SOLAR CAR PROJECT

The Stanford Solar Car Project is a student-run, donation-funded project that has been building and racing solar-powered vehicles since 1986. In the 2005 American Solar Challenge, Stanford's car won in the stock class. Stanford Solar provides hands-on experience for students in various fields of study and educates various groups on and off campus. <http://solarcar.stanford.edu/blog/>

STANFORD STUDENT BIODESIGN (SSB)

Founded in 2001, SSB has grown to be the largest student-run biomedical technology organization at Stanford, with a participating network of more than 800 Stanford students. We are supported by Stanford Biodesign and the Stanford School of Medicine, who share our goal of integrating students and faculty from various departments within Stanford. Stanford Student Biodesign and Biopharma connects members of the Stanford community with external supporters including alumni, biotechnology and medical device companies, and venture capital and private equity firms. <https://sites.google.com/site/ssbinformation/about>

STANFORD SOLAR WIND AND ENERGY PROJECT (SWEP)

The mission of the Stanford Solar and Wind Energy Project (SWEP) is to promote and develop renewable energy for Stanford University, while also providing practical career experience for undergraduate and graduate students. SWEP currently has ongoing projects in solar water heating, photovoltaic energy, wind energy and energy education. We welcome anyone to participate in our group and seek to collaborate with other student groups, faculty, university programs and community members. <http://inversion.stanford.edu/swep/drupal/>

9. SUMMER EMPLOYMENT AND CAREER PLANNING

Stanford's School of Engineering is fortunate to be part of a major university with strengths in the humanities and sciences as well as engineering. Our curriculum has been designed to encourage engineering students to take maximum advantage of Stanford's liberal arts by requiring a practical minimum of technical courses in the engineering major. This broader education does not handicap Stanford's engineering students once in the profession, because they are well trained in fundamentals and have broad skills required for leadership. However, one way to extend one's engineering training is through summer work experience. The School recommends that each student have a summer work experience or technical internship before graduation. Generally this can be arranged through the Career Development Center (CDC) if planning is started in the Fall Quarter. Some overseas work experiences are also available through the Overseas Resource Center of Bechtel International Center or through internships linked with the Overseas Studies Program in Berlin.

Career Development Center

Assistant Directors at the Career Development Center (CDC) assist undergraduate and graduate engineering students in exploring their passions, understanding their unique talents, and developing a successful career search strategy. Step one is to register with the CDC by establishing a Cardinal Careers account at

<https://studentaffairs.stanford.edu/cdc/jobs-internships>. Your account will give you:

- Access to the jobs database for full-time, part-time, internship and on-campus (including federal work study) opportunities
- Opportunity to:
 - a) Set up job search agents which will work for you to deliver jobs of interest
 - b) Include your resume in an e-resume book
 - c) Participate in the on-campus interview program, Cardinal Recruiting
 - d) Sign up to receive targeted career information

The following page has a listing of other key CDC resources/programs that you will find helpful:

- **Cardinal Recruiting:** Your opportunity to interview with companies on-campus. For more information about the types of companies that participate, how to register, and the relevant policies and procedures, please check out the CDC Cardinal Recruiting web page at <http://studentaffairs.stanford.edu/cdc/services/cardinal-overview>.
- **Career Fairs:** The CDC hosts a number of career fairs throughout the year. For more information, go to <http://studentaffairs.stanford.edu/cdc/services/career-fair-schedule>.
- **Resume Writing, Interviewing, and Job Hunting Strategies:** The CDC supports all aspects of the job search process. We have handouts, web pages, workshops, an extensive career resource library, and career counselors available to assist you with your job search. Information about our resources and services is at <http://studentaffairs.stanford.edu/cdc/services/>.
- **Meet Ups:** Attend a meet up and discuss, with peers, career topics specific to your needs. Meet ups are typically held three days a week, during the noon hour. Go to the CDC website to find information regarding specific dates and locations.
- **Calendar of Events:** For a comprehensive schedule of the CDC's programs and activities, go to <http://studentaffairs.stanford.edu/cdc/services/event-calendars>

OVERSEAS RESOURCE CENTER

The Overseas Resource Center (ORC), located on the second floor of the Bechtel International Center, offers advising for undergraduates, graduate students, post-docs, and recent alumni pursuing scholarships for study and research abroad. There are numerous opportunities for technical students who wish to pursue overseas study, research, or work opportunities. Visit the ORC or consult our website at <http://icenter.stanford.edu/orc> to find out what's available.

Scholarships for Study and Research Abroad.

The ORC is Stanford's advising center for numerous international scholarship opportunities. Information on several hundred scholarships – from travel grants to single/multi-year, fully-funded study and research opportunities – can be found in the ORC. We also hold group information sessions in the winter and spring quarters.

- **Rhodes, Marshall, Mitchell, and Fulbright Scholarships:** It is a common misconception that these scholarships are geared towards students in the humanities. Engineering students are strongly encouraged to look into these opportunities. The Rhodes and the Marshall awards are for study in the UK, the Mitchell is for study in Ireland and the Fulbright offers study or research worldwide.

- **Churchill Scholarships:** This award provides full financial support for one year of graduate work in engineering, mathematics, or the sciences at Churchill College, Cambridge University.
- **Gates Cambridge Scholarships:** These awards are offered to outstanding applicants outside the UK to pursue a graduate degree in any subject especially the STEM fields at the University of Cambridge.
- **German Academic Exchange (DAAD) Awards:** There are many opportunities for undergrads and graduates, especially those in the sciences, technology, engineering, and mathematics (STEM) fields, to study, research, intern, and attend language training programs in Germany, ranging from 3 weeks to one year through these awards.
- **Whitaker International Fellows and Scholars Program:** This program provides funding for young graduates to conduct research abroad in the field of biomedical engineering and bioengineering. The award is available for many countries.
- **Think Swiss Research Scholarship:** This award offers undergraduates or graduate students 2 to 3 months opportunity to conduct research at a public Swiss university or research institute. This is open to students in a variety of fields including science and engineering.
- For a full list of scholarships and awards, please visit the ORC website at <http://icenter.stanford.edu/orc/>.

Work Abroad

Information on short-term work, internships, and volunteer and teaching abroad opportunities for technical and non-technical students. Many resources can be found on the ORC website; listed here are a few of the most popular work abroad programs for Stanford students.

<http://www.stanford.edu/dept/icenter/orc/workabroad.html>

IAESTE Training Program

The International Association for the Exchange of Students for Technical Experience (IAESTE) is an exchange program that provides opportunities for on-the-job practical training for students in engineering, architecture, agriculture, mathematics, computer science, and natural and physical sciences in 70 member countries. Participants must have completed their sophomore year. Trainees are paid a maintenance allowance adequate to cover living costs while in training. Fluency in the language is required for some countries. For more information, please visit the IAESTE website at <http://www.iaeste.org>.

BUNAC

Coordinates work abroad, volunteering abroad and summer camp programs in Britain, Ireland, France, Australia, New Zealand, Canada, Peru, Ghana, South Africa and Cambodia. Please see the BUNAC website at <http://www.bunac.org>.

Useful Funding Resources

IIE Passport Study Abroad Funding

This valuable funding database allows you to search by country or subject to find the study abroad information that you need. You can do searches for technology and engineering fields too. <http://www.studyabroadfunding.org/>

Other services provided by the ORC

International Student Identification Cards (ISIC): The ORC is the office on campus that issues ISICs to students traveling abroad.

Passport photo taking service: The ORC provides a passport photo taking service. Please check the hours of this service.

FUNDAMENTALS OF ENGINEERING EXAM

Many engineers, especially those in Civil, Environmental, and Mechanical Engineering, will find it an important step in their careers to become Registered Professional Engineers in the state in which they intend to practice. The first step in becoming registered is to take and pass the Fundamentals of Engineering (FE) examination (formally the Engineering-In-Training, or EIT, exam). All engineering students should consider taking the FE exam, whether or not they currently envision becoming licensed engineers. The exam is broadly based, takes eight hours, and covers basic topics such as calculus, physics, chemistry, statics, thermodynamics, circuits, and so forth. It is much easier to pass the exam while these basic subjects are still relatively fresh in your mind, and hence it is highly recommended that the exam be taken toward the end of the senior year or shortly thereafter. Exams are given twice a year, in April and October, with a filing deadline that is approximately two and a half months previous to the test. For details and deadlines, visit <http://www.bpelsg.ca.gov/>

10. FORMS

To find Petition, Program Sheet and 4-Year plan forms, go to the Handbook web site, <http://ughb.stanford.edu>; check Navigation bar on left to find the correct page of forms and instructions.

Petitions

- **School of Engineering: Petition for Program Deviation:** Use this form to deviate from set requirements in Math, Science, TIS, or Fundamentals
- **Departmental Petition for Program Deviation:** Use this form to deviate from set requirements in Depth (core) courses
- **School of Engineering Petition for Transfer Credit:** Use this form to transfer credit for Math, Science, TIS, or Fundamentals courses
- **Departmental Petition for Transfer Credit:** Use this form to transfer credit for Depth (core) courses

11. INFORMATION FOR ADVISORS

Advising within the School of Engineering varies somewhat depending upon the category of student involved. Engineering advisors are typically assisting graduate students, undergraduates who have declared their major, and undeclared undergraduates who have indicated a preliminary academic interest in engineering. This Handbook deals only with undergraduates.

Advising of undergraduates can occur on many levels. Most of the questions that advisees will bring to you relate to specific requirements for an engineering degree at Stanford. This *Handbook for Undergraduate Engineering Programs* is meant to serve both you and your advisees as the source of most of the answers to such questions. Further clarifications on curricula can be obtained from the Office of Student Affairs in 135 Huang, 723-5984.

There is, of course, no manual to turn to for the most valuable information that you will be able to impart to your advisees, which is based on your knowledge, wisdom, and personal experiences. The individual counseling of your students on matters of personal concern to them is probably the most valuable function that you will perform.

At times, you may feel the need to refer the student to any of a variety of support services offered by the School and University, including: Undergraduate Advising and Research (UAR), the Center for Teaching and Learning (CTL), Engineering Diversity Programs (135 Huang), the Career Development Center (CDC), Counseling and Psychological Services (CAPS), Vaden Health Center, the Bechtel International Center, the University Ombudsperson, and the Dean of Students. Undergraduate Advising and Research also provides resources and general information at <http://undergrad.stanford.edu/>.

Advisors are strongly encouraged to make themselves available on a regular basis to their advisees, but in particular it is essential that each advisor schedule a liberal number of office hours during registration periods. During these registration periods, students frequently need to be able to stop by to obtain necessary signatures and advice. Your indulgence in these sometimes-unscheduled visits is greatly appreciated by the students as they go about their rush of activities.

To advise pre-major students, Undergraduate Advising and Research (UAR) assigns each new freshman and transfer student a **Pre-Major Advisor** and an **Academic Director**. Pre-Major Advisors are Stanford faculty and staff who volunteer to advise up to six incoming freshmen from the time they arrive at Stanford until the time they declare their major (typically during the

sophomore year). UAR asks only that Pre-Major Advisors do what they already do best as scholars, teachers, and/or higher education administrators: inspire students to embrace the next four years of their life with the full depth of their curiosity. Although Pre-Major Advisors are encouraged to engage a student across his or her full range of interests, they are not required to know the specifics of majors that lie well outside of their own expertise. In such instances, Pre-Major Advisors may either consult with the student's Academic Director or refer the student directly to the Academic Director.

The **Academic Director** serves as UAR's representative in every residence that houses undergraduate students. To accomplish such far-reaching support, nearly all Academic Directors serve multiple residences, with an office located in a residence that is geographically proximate to the residences they serve. Each Academic Director can advise on Stanford's undergraduate curriculum, research and public service opportunities, academic rules and regulations, and other campus resources. Academic Directors are available five days per week to discuss logistics, course selection, majors, units, overseas studies, transfer credit, and academic standing with undergraduate students.

UAR also has Academic Advisors for Student-Athletes who work specifically with student athletes, particularly regarding the strict NCAA compliance guidelines to which all student athletes must adhere. UAR Advisors in Sweet Hall provide general advising for all class years and special advising for pre-professional planning such as the health professions (*e.g.*, medicine) and law.

Major Advising in Engineering: For advisees who declare your department as their major, one of your principal administrative responsibilities is the approval of their Program Sheet. This document is usually submitted twice, once when they declare and again during their senior year as they prepare to graduate. You must certify that their course work meets the degree requirements established by your own department and by the School of Engineering. As mentioned in this Handbook, deviations within the category of Engineering Depth must be approved by a student's advisor – including approval of courses transferred from another institution. Your approval of such variances is indicated by initialing and dating the entry on the Program Sheet.

ADVISING UNDERGRADUATE ENGINEERING STUDENTS

WHEN STUDENT DECLARES A MAJOR

- Review Program Sheet (PS), ensuring it includes required courses and units as stated in UGHB PS samples (given in Chapter 5, *Program Descriptions and Requirements for Engineering Majors*; a student may use a Program Sheet from any year they are enrolled at Stanford)
- Inform student of how and when to use the Petition process (to deviate from Depth or SoE requirements; to transfer course credit for units taken outside of Stanford – see UGHB, Chapter 4 for details)
- ABET-accredited majors: Make sure that the advisee is aware of having to meet the required 68 units of Engineering Science and Engineering Design by the end of their undergraduate career (UGHB, Chapter 3). In some cases, additional courses beyond the required courses may be needed to meet the minimum requirement.
- Fall or winter quarter of their senior year, all SoE students must complete and have signed by their advisor an updated PS (the OSA will not review the version that was used to declare)..

TO PREPARE STUDENT FOR GRADUATION

Review Program Sheet, looking for the following:

- Check that all required Depth courses have been taken OR will be taken Senior year OR the student has deviation/transfer petitions approved by the advisor/department in their file
- Check that minimum unit totals required by the department, as stated on their chosen Program Sheet, have been met for Math, Science, TIS, WIM, Fundamentals, and Depth.
- If you have a Math/Sci/Fund/TIS class that you require for your major, please check progress toward completion since **students rarely come into OSA to check their progress unless specifically petitioning to transfer credit or deviate**. Example: A CE student should be told s/he has not fulfilled their TIS requirement for CE unless the course they have chosen is one approved specifically for CE majors (see Chapter 3, Fig. 3-3). This select list is specific to the CE major and should be drawn to the attention of the student by the department.
- Check that an approved Writing in the Major (WIM) course has been/will be completed (see Program Sheet footnotes for appropriate course[s])
- ABET-accredited majors: Make sure that the advisee will meet the required 68 units of Engineering Science and Engineering Design units by the end of their undergraduate career (this total may be different than the course unit [Depth] total since some writing or professional courses do not count towards ABET; see UGHB, Chapter 3 or footnotes on the Program Sheets)
- ***Please DO NOT sign a Program Sheet without ensuring that all Depth and ABET requirements have or will be met by the student's final quarter.***