

NOTES:

1. STANDARD SECONDARY CONNECTION SHALL BE MADE WITH EXTRA FLEXIBLE CABLE AS SHOWN ON SHT 7 & 8 IN ACCORDANCE WITH CPAU DRAWING DT-SE-U-1032. ALTERNATIVELY, A BUSWAY ASSEMBLY AS SHOWN ON SHT. 5 MAY BE USED, WITH UTILITIES' APPROVAL, TO CONNECT THE TRANSFORMER SECONDARY TERMINALS TO THE BUSWAY INSIDE THE TRANSFORMER SECONDARY COMPARTMENT.
2. FOR SERVICE LARGER THAN 1600 AMPS, THE CUSTOMER MAY INSTALL BUSWAY FROM THE CUSTOMER'S SWITCHGEAR DIRECTLY TO UTILITY'S PADMOUNT TRANSFORMER, WITH UTILITIES' APPROVAL.
3. ANY ATTACHMENT TO THE TRANSFORMER SECONDARY TERMINALS SHALL BE PERFORMED BY UTILITIES.
4. ALL BUSWAY DESIGN AND CONFIGURATION SHALL BE SUBMITTED TO UTILITIES FOR REVIEW & APPROVAL PRIOR TO PROCUREMENT AND FABRICATION.
5. BUSWAY SHALL CONFORM TO ARTICLE 364 OF THE NATIONAL ELECTRICAL CODE.
6. BUSWAY SHALL BE RATED ACCORDING TO THE SERVICE ENTRANCE OVERCURRENT PROTECTION DEVICE AND FABRICATED PER ANSI 37.23.
7. THE DESIGNATED SERVICE POINT SHALL BE THE SECONDARY TERMINALS OF THE TRANSFORMER.
8. THE TRANSITION CABINET SHALL BE FABRICATED PER DRAWING # SR-XF-E-1020 SHT. 6 OR APPROVED EQUIVALENT.
9. UTILITIES (AT CUSTOMER'S EXPENSE) WILL PROVIDE LUGS ON THE TRANSFORMER SECONDARY TERMINALS. CUSTOMER SHALL PROVIDE/INSTALL LUGS AND TERMINATE CABLES AT SWITCHGEAR OR TRANSITION CABINET.

TRANSITION CABINET FOR 1000-2500 KVA TRANSFORMERS

| | |
|---------------------|--------------------------------------------|
| APPROVED | <i>MOR</i> |
| SR. PROJECT MANAGER | <i>and Approved by Engineering Manager</i> |
| ENGR. | G. Jagath |
| DRWN | M. Manshid |
| CHKD. | P. Valath |

TRANSITION CABINET



City of Palo Alto
California
UTILITIES, ELECTRIC ENGINEERING

| | | | |
|-------|-------|--------|----------------------------------------------------|
| 5 | 6/13 | TING | ADDED NOTE 9 & OTHER MINOR REVISION |
| 4 | 12/08 | TING | REVISED NOTES |
| 3 | 02/06 | BUJTOR | CONVERTED TO A/CAD, REVISED NOTES & ADDED DWG. NO. |
| 2 | 06/99 | FINCH | REVISED NOTES |
| 1 | 3/94 | APPR. | DRAWING RENAMED |
| REV. | DATE | APPR. | DESCRIPTION |
| MAP # | CKT # | SCALE | S.O.# / DRAWING # |
| XX | XX | NTS | SR-XF-E-1020 |
| | | | SHEET 1 OF 8 |

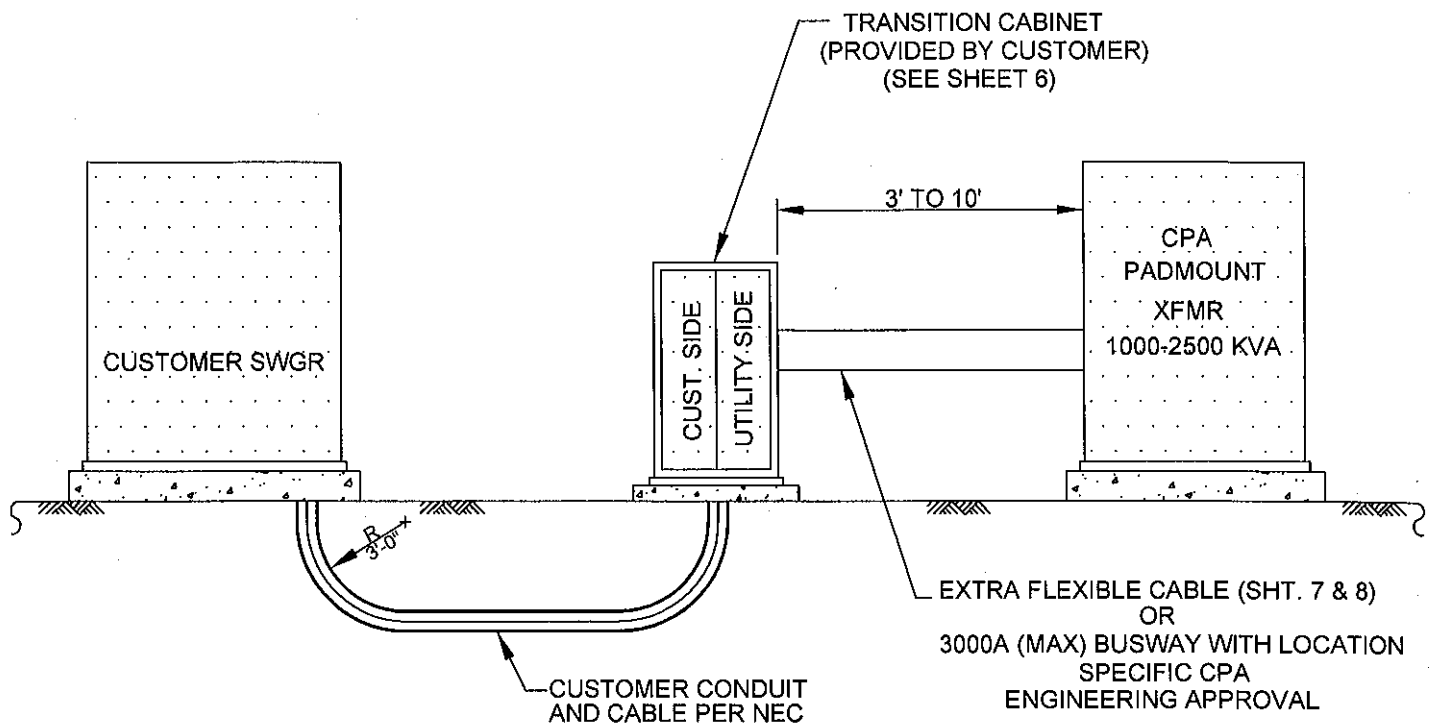

NOTES:

1. STANDARD SECONDARY CONNECTION SHALL BE MADE WITH EXTRA FLEXIBLE CABLE AS SHOWN ON SHT. 7 & 8 IN ACCORDANCE WITH CPAU DRAWING DT-SE-U-1032. ALTERNATIVELY, A BUSWAY ASSEMBLY AS SHOWN ON SHT. 5 MAY BE USED, WITH UTILITIES' APPROVAL, TO CONNECT THE TRANSFORMER SECONDARY TERMINALS TO THE BUSWAY INSIDE THE TRANSFORMER SECONDARY COMPARTMENT.
2. THE CUSTOMER MAY, WITH UTILITIES' APPROVAL, INSTALL BUSWAY FROM TRANSFORMER TO TRANSITION CABINET AND CABLES FROM TRANSITION CABINET TO CUSTOMER SWITCHGEAR FOR TRANSFORMERS RATED 1000 KVA TO 2500 KVA.
3. ANY ATTACHMENT TO THE TRANSFORMER SECONDARY TERMINALS SHALL BE PERFORMED BY UTILITIES.
4. ALL BUSWAY DESIGN AND CONFIGURATION SHALL BE SUBMITTED TO UTILITIES FOR REVIEW & APPROVAL PRIOR TO PROCUREMENT AND FABRICATION.
5. BUSWAY SHALL CONFORM TO ARTICLE 364 OF THE NATIONAL ELECTRICAL CODE.
6. BUSWAY SHALL BE RATED ACCORDING TO THE SERVICE ENTRANCE OVERCURRENT PROTECTION DEVICE AND FABRICATED PER ANSI 37.23.
7. THE DESIGNATED SERVICE POINT SHALL BE THE SECONDARY TERMINALS OF THE TRANSFORMER.
8. THE TRANSITION CABINET SHALL BE FABRICATED PER DRAWING # SR-XF-E-1020 SHT. 6 OR APPROVED EQUIVALENT.
9. UTILITIES (AT CUSTOMER'S EXPENSE) WILL PROVIDE LUGS ON THE TRANSFORMER SECONDARY TERMINALS. CUSTOMER SHALL PROVIDE/INSTALL LUGS AND TERMINATE CABLES AT SWITCHGEAR OR TRANSITION CABINET.

TRANSITION CABINET FOR 1000-2500 KVA TRANSFORMERS

| | |
|----------------------|----------------------------------------|
| APPROVED | <i>M.D. Signed</i> |
| SR. ENGINEER MANAGER | <i>Approved by Engineering Manager</i> |
| ENGR. | S. P. Garg |
| DRWN | M. Shid |
| CHKD. | P. Valath |

TRANSITION CABINET



City of Palo Alto
California
UTILITIES, ELECTRIC ENGINEERING

| | | | |
|-------|-------|--------|----------------------------------------------------|
| 5 | 6/13 | TING | ADDED NOTE 9 & OTHER MINOR REVISIONS |
| 4 | 12/08 | TING | REVISED NOTES |
| 3 | 02/06 | BUJTOR | CONVERTED TO A/CAD, REVISED NOTES & ADDED DWG. NO. |
| 2 | 06/99 | FINCH | REVISED NOTES |
| 1 | 3/94 | APPR. | DRAWING RENAMED |
| REV. | DATE | APPR. | DESCRIPTION |
| MAP # | CKT # | SCALE | S.O.# / DRAWING # |
| XX | XX | NTS | SR-XF-E-1020 |
| | | | SHEET 2 OF 8 |

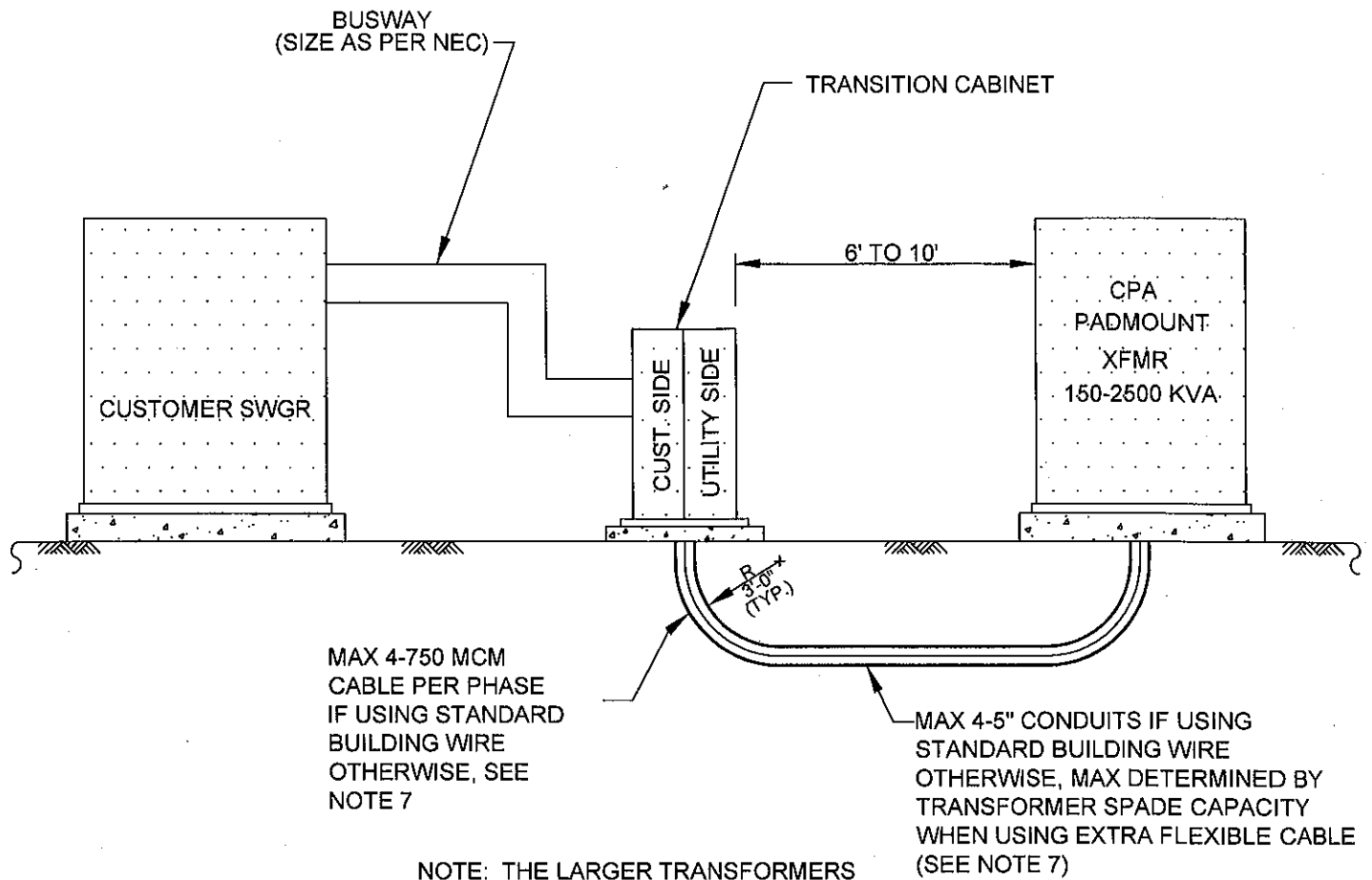

MAX 4-750 MCM
CABLE PER PHASE
IF USING STANDARD
BUILDING WIRE
OTHERWISE, SEE
NOTE 7

MAX 4-5" CONDUITS IF USING
STANDARD BUILDING WIRE
OTHERWISE, MAX DETERMINED BY
TRANSFORMER SPADE CAPACITY
WHEN USING EXTRA FLEXIBLE CABLE
(SEE NOTE 7)

NOTE: THE LARGER TRANSFORMERS
THEREFORE REQUIRE EXTRA FLEXIBLE
CABLE TO MEET CPAU REQUIREMENTS.

NOTES:

1. UTILITIES SHALL FURNISH, INSTALL AND CONNECT THE SERVICE LATERAL CONDUCTORS BETWEEN THE TRANSITION CABINET AND TRANSFORMER SECONDARY TERMINALS IF STANDARD BUILDING WIRE IS USED. OTHERWISE THE CUSTOMER FURNISHES AND INSTALLS EXTRA FLEXIBLE CABLE PER SHT. 7 & 8 IN ACCORDANCE WITH CPAU DRAWING # DT-SE-U-1032.
2. CUSTOMER HAS THE OPTION TO INSTALL BUSWAY FROM THE CABINET TO THE SWITCHGEAR.
3. ALL BUSWAY DESIGN AND CONFIGURATION SHALL BE SUBMITTED TO UTILITIES FOR REVIEW AND APPROVAL PRIOR TO PROCUREMENT AND FABRICATION.
4. BUSWAY SHALL CONFORM TO ARTICLE 364 OF THE NATIONAL ELECTRICAL CODE.
5. THE DESIGNATED SERVICE POINT SHALL BE THE CUSTOMER SUPPLIED TRANSITION CABINET IF USING STANDARD BUILDING CABLE, THE SECONDARY TERMINALS OF THE TRANSFORMER IF USING EXTRA FLEXIBLE CABLE.
6. THE TRANSITION CABINET SHALL BE FABRICATED PER DRAWING # SR-XF-E-1020 SHT. 6 OR APPROVED EQUIVALENT.
7. IF USING EXTRA FLEXIBLE CABLE WHERE CABLE AND CONDUITS PER PHASE CAN BE EXCEEDED, CONFIRM THAT TRANSFORMER SPADES HAVE ADEQUATE CONNECTOR HOLES AND HAVE VERTICAL STRUCTURAL SUPPORTS (REF. SHT. 7 & 8).
9. UTILITIES (AT CUSTOMER'S EXPENSE) WILL PROVIDE LUGS ON THE TRANSFORMER SECONDARY TERMINALS. CUSTOMER SHALL PROVIDE/INSTALL LUGS AND TERMINATE CABLES AT SWITCHGEAR OR TRANSITION CABINET.

TRANSITION CABINET FOR 150-2500 KVA TRANSFORMERS

| | | | |
|-------|-------|--------|----------------------------------------------------|
| 4 | 12/08 | TING | REVISED NOTES |
| 3 | 02/06 | SUJTOR | CONVERTED TO A/CAD, REVISED NOTES & ADDED DWG. NO. |
| 2 | 06/99 | FINCH | REVISED NOTES |
| 1 | 3/94 | APPR. | DRAWING RENAMED |
| REV. | DATE | APPR. | DESCRIPTION |
| MAP # | CKT # | SCALE | S.O.# / DRAWING # |
| XX | XX | NTS | SR-XF-E-1020 |
| | | | SHEET 3 OF 8 |

| | |
|------------------------|--------------------------------------------|
| APPROVED | <i>MO</i> |
| SR. ENGINEER / MANAGER | <i>and Approved by Engineering Manager</i> |
| ENGR. | G. Jagannath |
| DRWN | M. Manshid |
| CHKD. | P. Valath |



TRANSITION CABINET

City of Palo Alto
California

UTILITIES, ELECTRIC ENGINEERING

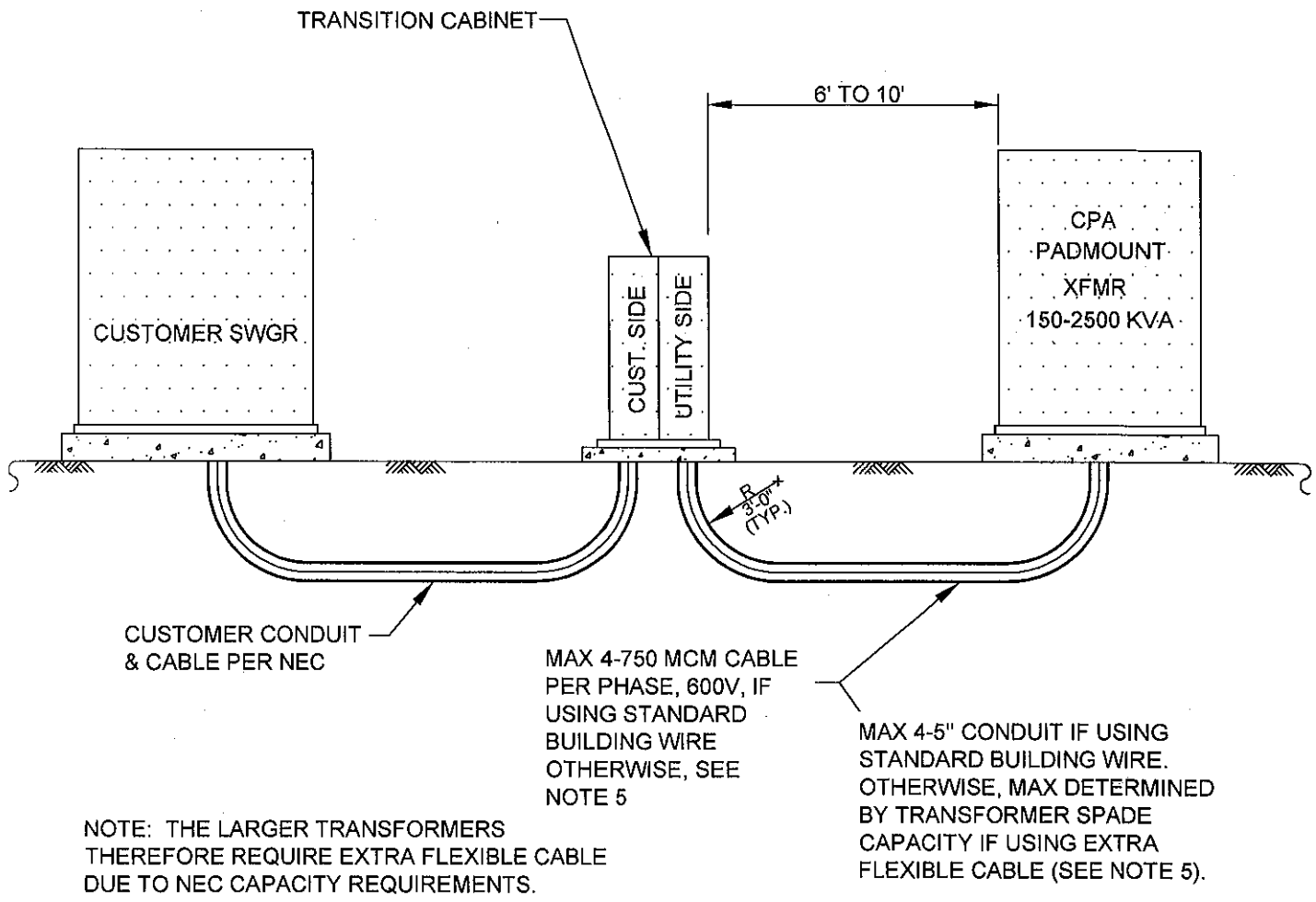

NOTE: THE LARGER TRANSFORMERS THEREFORE REQUIRE EXTRA FLEXIBLE CABLE DUE TO NEC CAPACITY REQUIREMENTS.

MAX 4-5" CONDUIT IF USING STANDARD BUILDING WIRE. OTHERWISE, MAX DETERMINED BY TRANSFORMER SPADE CAPACITY IF USING EXTRA FLEXIBLE CABLE (SEE NOTE 5).

NOTES:

1. THE CITY SHALL FURNISH, INSTALL AND CONNECT THE SERVICE LATERAL CONDUCTORS BETWEEN THE TRANSITION CABINET AND TRANSFORMER SECONDARY TERMINALS IF STANDARD BUILDING WIRE IS USED. OTHERWISE THE CUSTOMER FURNISHES AND INSTALLS EXTRA FLEXIBLE CABLE PER SHT. 7 & 8 IN ACCORDANCE WITH CPAU DRAWING # DT-SE-U-1032.
2. CUSTOMER SHALL INSTALL CABLES FROM THE TRANSITION CABINET TO THE SWITCHGEAR.
3. THE DESIGNATED SERVICE POINT SHALL BE THE CUSTOMER SUPPLIED TRANSITION CABINET.
4. THE TRANSITION CABINET SHALL BE FABRICATED PER DRAWING # SR-XF-E-1020 SHT. 6 OR APPROVED EQUIVALENT.
5. IF USING EXTRA FLEXIBLE CABLE WHERE CABLE AND CONDUITS PER PHASE CAN BE EXCEEDED, CONFIRM THAT TRANSFORMER SPADES HAVE ADEQUATE CONNECTOR HOLES AND HAVE VERTICAL STRUCTURAL SUPPORTS (REF. SHT. 7 & 8).
9. UTILITIES (AT CUSTOMER'S EXPENSE) WILL PROVIDE LUGS ON THE TRANSFORMER SECONDARY TERMINALS. CUSTOMER SHALL PROVIDE/INSTALL LUGS AND TERMINATE CABLES AT SWITCHGEAR OR TRANSITION CABINET.

TRANSITION CABINET FOR 150-2500 KVA TRANSFORMERS

| | |
|--------------|----------------|
| APPROVED | <i>MDP</i> |
| SR. ENGINEER | <i>Manager</i> |
| ENGR. | G. Jagath |
| DRWN | M. Mshid |
| CHKD. | P. Valath |

TRANSITION CABINET



City of Palo Alto
California
UTILITIES, ELECTRIC ENGINEERING

| | | | |
|-------|-------|--------|-----------------------------------------------------|
| 4 | 12/08 | TING | REVISED NOTES |
| 3 | 02/06 | BUJTOR | CONVERTED TO A/CAD, REVI'SD. NOTES & ADDED DWG. NO. |
| 2 | 06/99 | FINCH | REVISED NOTES |
| 1 | 3/94 | APPR. | DRAWING RENAMED |
| REV. | DATE | APPR. | DESCRIPTION |
| MAP # | CKT # | SCALE | S.O.# / DRAWING # |
| XX | XX | NTS | SR-XF-E-1020 |
| | | | SHEET 4 OF 8 |

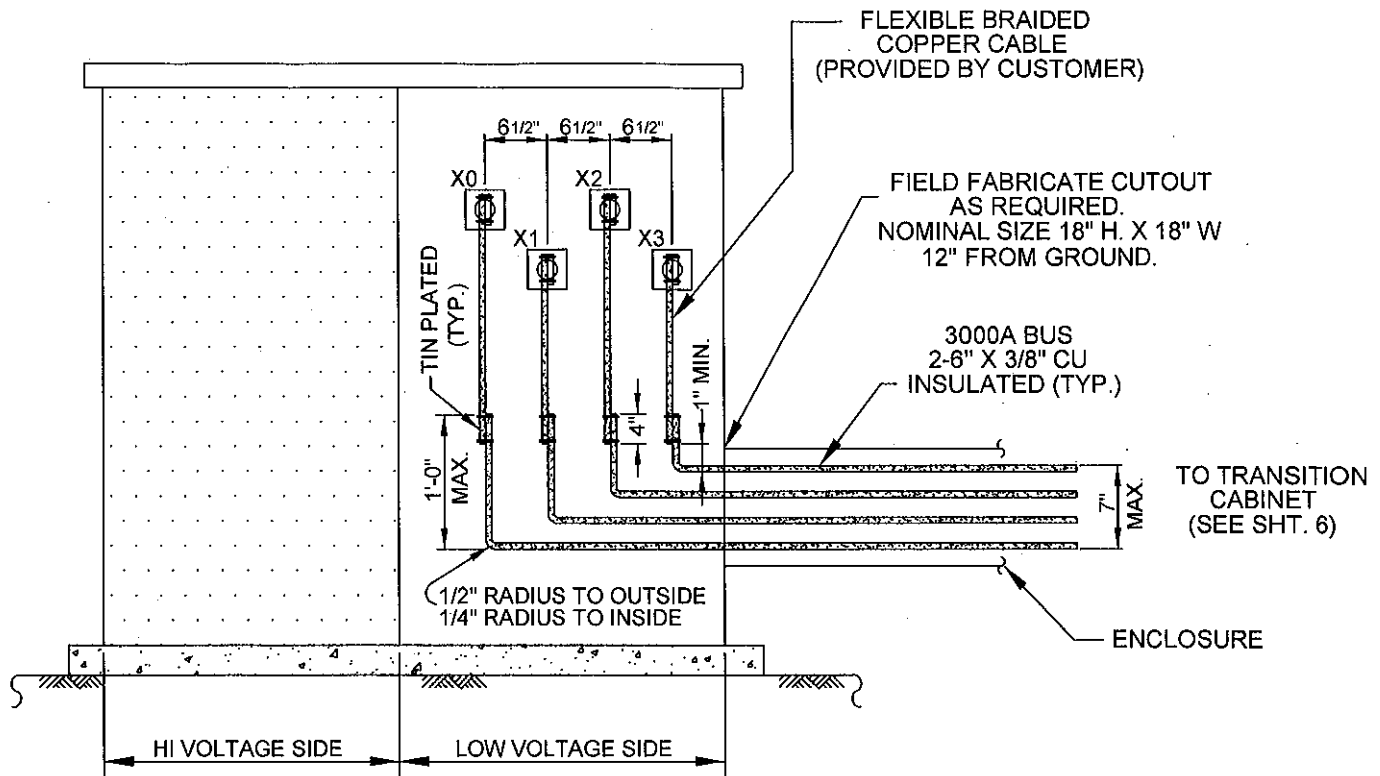

PADMOUNT 3-PHASE DISTRIBUTION TRANSFORMER 1000-2500 KVA

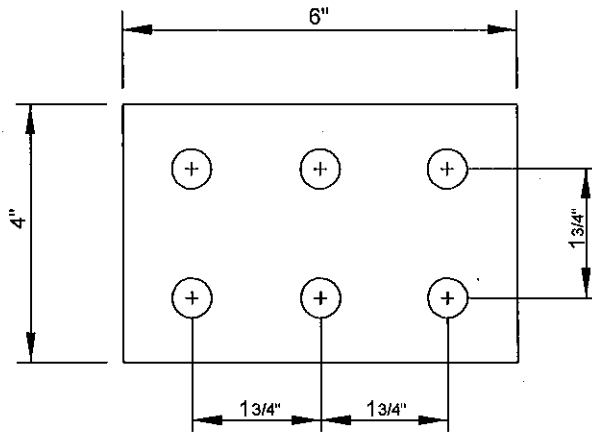





PAD VIEW
(TYPICAL)

NOTES:

- STANDARD SECONDARY CONNECTION WILL BE MADE WITH EXTRA FLEXIBLE CABLE AS SHOWN ON SHTS. 7 & 8. THIS BUSWAY ARRANGEMENT IS WITH LOCATION SPECIFIC CPA ENGINEERING APPROVAL ONLY. REFERENCE SHTS. 1 & 2.

3000 AMP BUSWAY ARRANGEMENT AT TRANSFORMER

| | | | | | | | |
|-------------------------------------------------------------------------------------------------------------------------------------------------------------------------------------------------------------------------------------------------------------------------------------|--|--------------------------------------------------------------------------------------------------------------------------------------------------------|--|-------|-------|--------|----------------------------------------------------|
| APPROVED  SR. ENGINEER / MANAGER | | TRANSITION CABINET | | REV. | DATE | APPR. | DESCRIPTION |
| | | | | 1 | 3/94 | APPR. | DRAWING RENAMED |
| ENGR.  DRWN.  CHKD.  | |  City of Palo Alto California UTILITIES, ELECTRIC ENGINEERING | | 2 | 06/99 | FINCH | REVISED NOTES |
| | | | | 3 | 02/06 | BUJTOR | CONVERTED TO A/CAD, REVISED NOTES & ADDED DWG. NO. |
| | | | | MAP # | CKT # | SCALE | S.O.# / DRAWING # |
| | | | | XX | XX | NTS | SR-XF-E-1020 |
| | | | | | | | SHEET 5 OF 8 |

NOTES:

1. SCREWS SHALL BE PROVIDED FOR THE TRANSITION CABINET COVERS BY THE MANUFACTURER AS REQUIRED.
2. TWO SEALABLE STUDS WITH WING NUTS SHALL BE PROVIDED FOR EACH TRANSITION CABINET COVER.
3. TRANSITION CABINET WILL BE I.E.M. OR APPROVED EQUIVALENT.

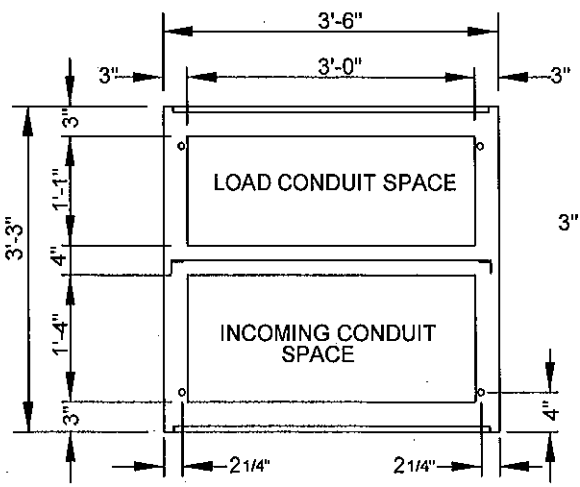
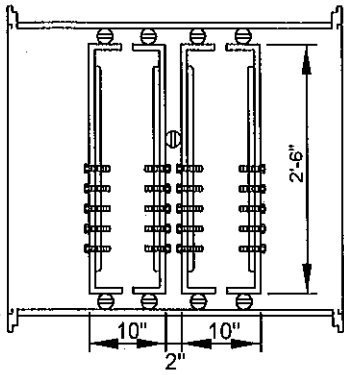

BASE DETAIL

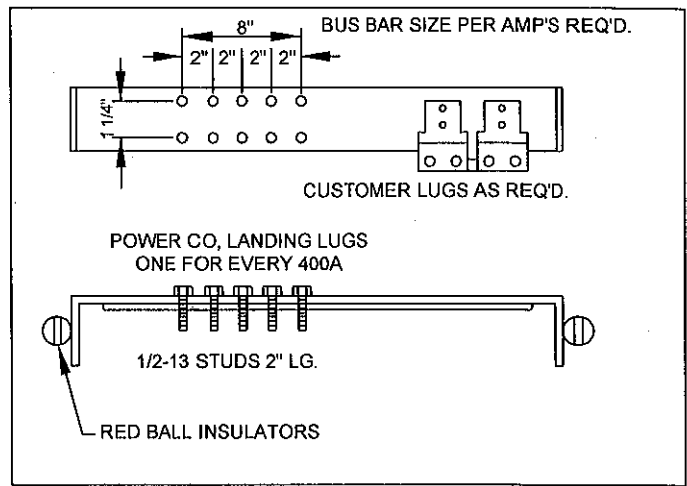

BLOW UP VIEW

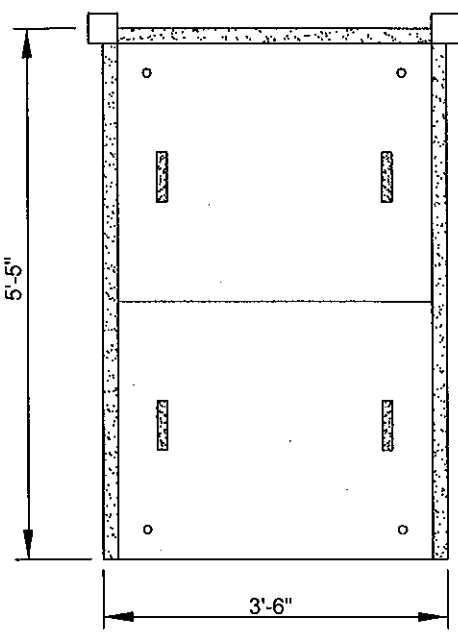

FRONT VIEW

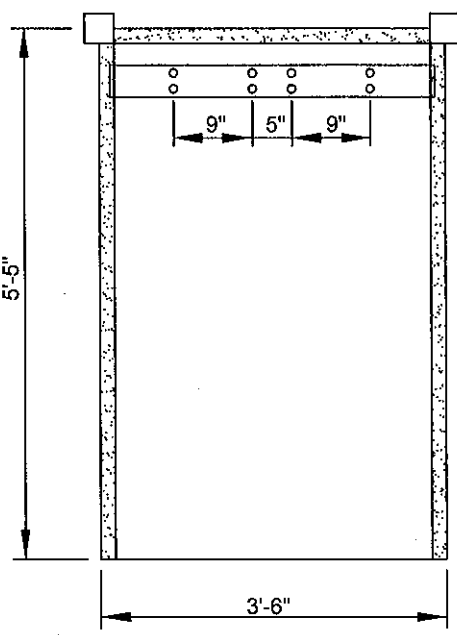

FRONT INTERIOR VIEW

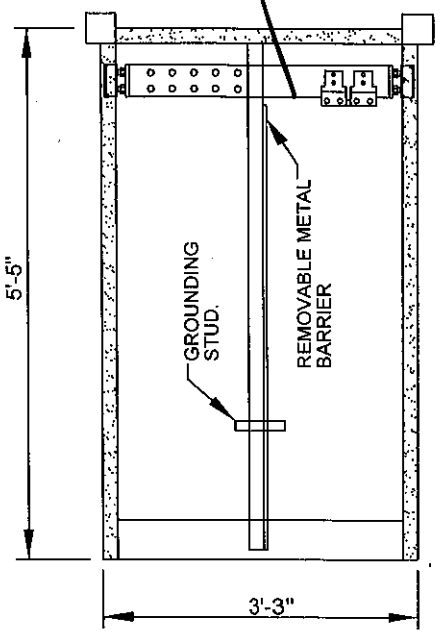

SIDE VIEW

TYPICAL TRANSITION CABINET FOR LARGER SERVICES

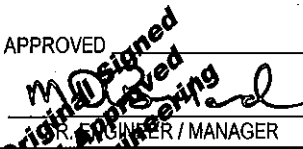
APPROVED

 ENGINEER / MANAGER
 M. Jamshid
 DRIVER
 M. Jamshid
 CHKD. P. Valath

TRANSITION CABINET



City of Palo Alto
 California
 UTILITIES, ELECTRIC ENGINEERING

| REV. | DATE | APPR. | DESCRIPTION |
|-------|-------|--------|----------------------------------------------------|
| 1 | 3/94 | APPR. | DRAWING RENAMED |
| 2 | 06/99 | FINCH | REVISED NOTES |
| 3 | 02/06 | BUJTOR | CONVERTED TO A/CAD, REVISED NOTES & ADDED DWG. NO. |
| MAP # | CKT # | SCALE | S.O.# / DRAWING # |
| XX | XX | NTS | SR-XF-E-1020 |
| | | | SHEET 6 OF 8 |

USE 2-HOLE LONG BARREL CRIMP TYPE COMPRESSION CONNECTORS SIZED FOR CABLE ON BOTH ENDS; BURNDY TYPE YA38L2NNTFX OR EQUAL. SEE DETAIL 1, SHEET 8

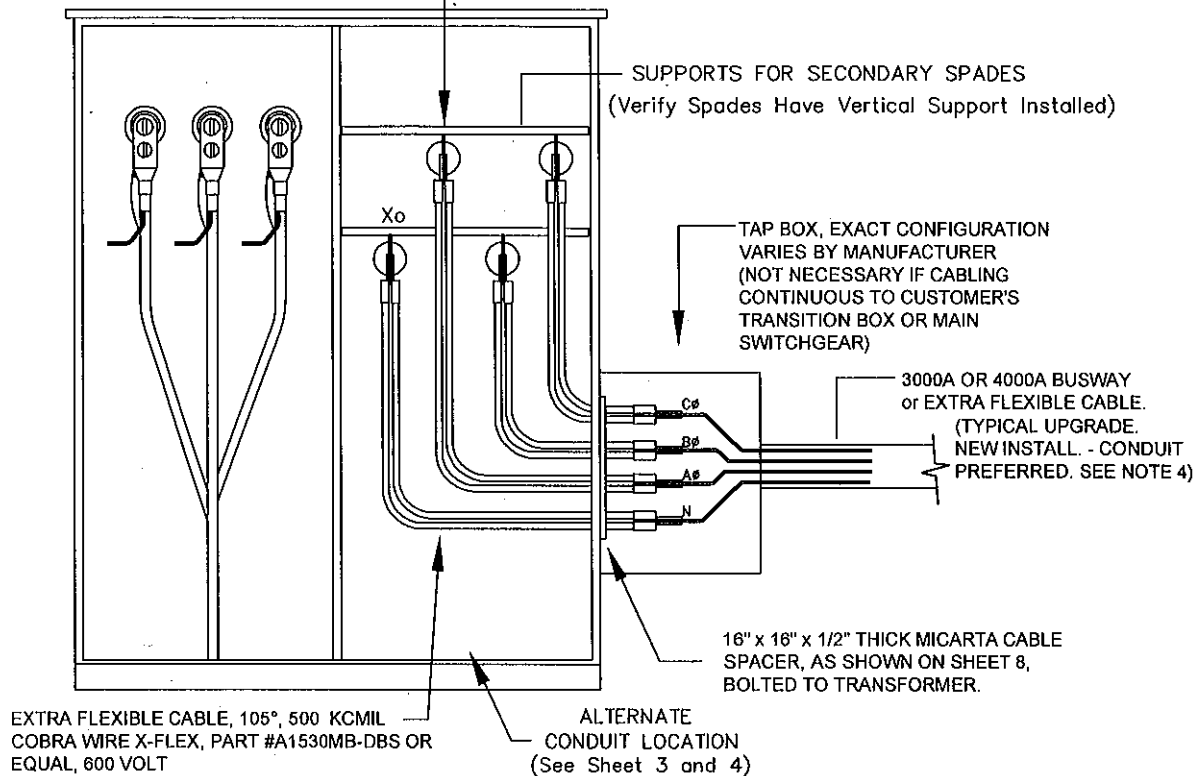

EXTRA FLEXIBLE CABLE, 105°, 500 KCMIL
COBRA WIRE X-FLEX, PART #A1530MB-DBS OR
EQUAL, 600 VOLT

ALTERNATE
CONDUIT LOCATION
(See Sheet 3 and 4)

UTILITY GUIDE ONLY:

- 750 KVA: 4 (@ 480 V) OR 6 (@ 208 V) CONDUCTORS PER PHASE AND NEUTRAL
- 1000 KVA: 4 CONDUCTORS PER PHASE AND NEUTRAL
- 1500 KVA: 4 CONDUCTORS PER PHASE AND NEUTRAL
- 2000 KVA: 6 CONDUCTORS PER PHASE AND NEUTRAL
- 2500 KVA: 7 CONDUCTORS PER PHASE AND NEUTRAL

NOTES:

1. CABLE TO BE SIZED PER CPAU DWG # DT-SE-U-1032. IF USING ALTERNATE CONDUIT LOCATION, STANDARD CABLE MAY BE USED, NOT TO EXCEED 4-750 MCM PER PHASE AND IN ACCORDANCE WITH CPAU DWG # DT-SE-U-1032.
2. THE DESIGNATED SERVICE POINT PER THE NATIONAL ELECTRIC CODE SHALL BE THE SECONDARY TERMINALS AT THE TRANSFORMER.
3. THE CUSTOMER SHALL FURNISH ALL HARDWARE AND MATERIALS NEEDED FOR A COMPLETE INSTALLATION.
4. IF GREATER THAN 3000A SERVICE, CALL CPA UTIL. ENGR. DEPT. AT 566-4500. USE OF 750KCMIL AND ELIMINATION OF TRANSITION CABINET MAY BE POSSIBLE.
5. CABLING BETWEEN TRANSFORMER AND CUSTOMER'S SWITCHGEAR SHALL BE SIZED PER CPAU DWG # DT-SE-U-1032 IF NOT USING A TRANSITION CABINET.

BUSWAY CONNECTION FOR TRANSFORMER SECONDARY

| |
|------------------|
| APPROVED _____ |
| ENGINEER MANAGER |
| DRWN: T. CHAPPI |
| CHKD: M. ZUCCARO |

TRANSITION CABINET



City of Palo Alto
California
UTILITIES, ELECTRIC ENGINEERING

| | | | |
|-------|-------|--------|----------------------------------------------------|
| 5 | 1/12 | TING | REVISED UTL GUIDE |
| 4 | 12/08 | TING | REVISED NOTES |
| 3 | 02/06 | BUJTOR | CONVERTED TO A/CAD, REVISED NOTES & ADDED DWG. NO. |
| 2 | 06/99 | FINCH | REVISED NOTES |
| 1 | 3/94 | APPR. | DRAWING RENAMED |
| REV. | DATE | APPR. | DESCRIPTION |
| MAP # | CKT # | SCALE | S.O.# / DRAWING # |
| XX | XX | NTS | SR-XF-E-1020 |
| | | | SHEET 7 OF 8 |

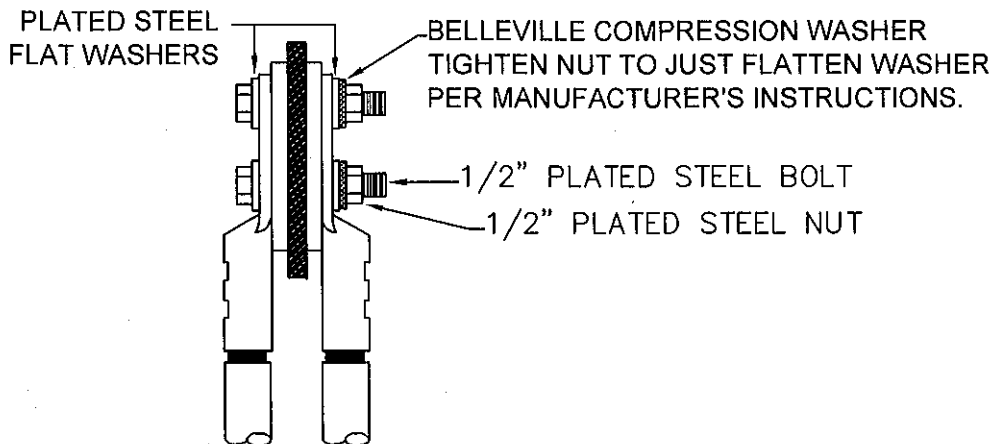

DETAIL 1: SECONDARY CABLE CONNECTION

MATERIALS

COMPRESSION CONNECTORS: BURNDY YA38L2NNTFX (OR EQUIVALENT) CONNECTOR FOR 535.3 KCMIL CABLE WITH DIE (BURNDY L99) RECOMMENDED BY TOOL MANUFACTURER.

BELLEVILLE SPRING WASHERS: T&B STAINLESS STEEL, 1/2"; #50050BW

CANVAS MICARTA BOARD: RIDOUT PLASTICS, WWW.RIDOUTPLASTICS.COM, 858.560.1551, ANGUS-CAMPBELL, INC. 323.587.1236, OR PORT PLASTICS, 408.571.2231

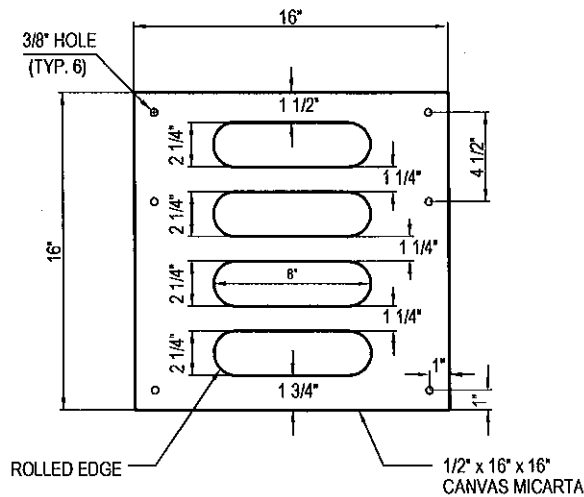

BUSWAY CONNECTION FOR TRANSFORMER SECONDARY

| | |
|-------------|------------|
| APPROVED | |
| DESIGNED BY | MANAGER |
| DRWN | PPPI |
| CHKD. | S. ZUCCARO |

TRANSITION CABINET



City of Palo Alto
California
UTILITIES, ELECTRIC ENGINEERING

| | | | |
|-------|-------|--------|----------------------------------------------------|
| 5 | 6/13 | TING | REVISED MATERIAL NOTE |
| 4 | 12/08 | TING | REVISED BOARD |
| 3 | 02/06 | BUJTOR | CONVERTED TO A/CAD, REVISED NOTES & ADDED DWG. NO. |
| 2 | 06/99 | FINCH | REVISED NOTES |
| 1 | 3/94 | APPR. | DRAWING RENAMED |
| REV. | DATE | APPR. | DESCRIPTION |
| MAP # | CKT # | SCALE | S.O.# / DRAWING # |
| XX | XX | NTS | SR-XF-E-1020 |
| | | | SHEET 8 OF 8 |