

# Draw Solution Revolution – Evaluation of Mixed Draw Solutions for Improved FO Performance

Research Team Members:

Mentors: Tzahi Cath, Ph.D. and Ryan Holloway

Participant: Rudy Maltos

## Background:

- Forward Osmosis (FO) – engineered osmosis, which is the ability of water to pass through a membrane. **Fig 1.**
- Draw Solution (DS) – A saline solution, typically sodium chloride.
- Feed Solution – Could be any influent, DI water, wastewater, etc.
- Thin film composite membrane (TFC) – a semi-permeable membrane with a slightly negative charge

FO can be implemented in a variety of water treatment processes. FO has the ability of separating water molecules from harmful water constituents through osmosis. Water molecules are drawn to the DS due to its high osmotic pressure, diffusing through the TFC. In order to improve FO performance the amount of salt ions leaving the DS must be reduced, this process is called the reverse salt flux (RSF).

## Objective:

1. Reduce RSF **Fig 2.**
2. Maintain water flux

**Figure 1.** Semi-permeable membrane

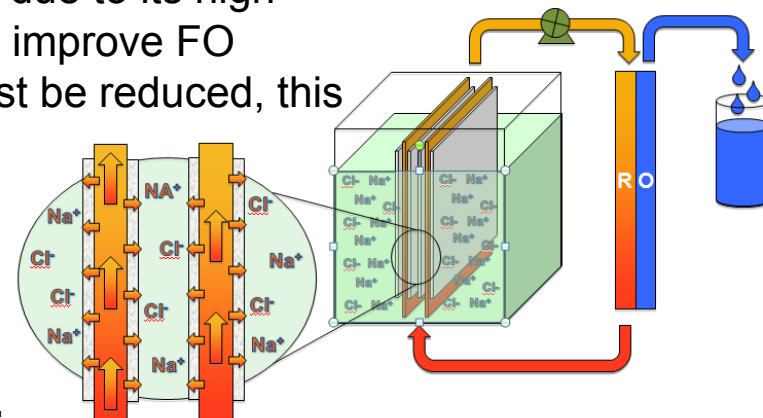
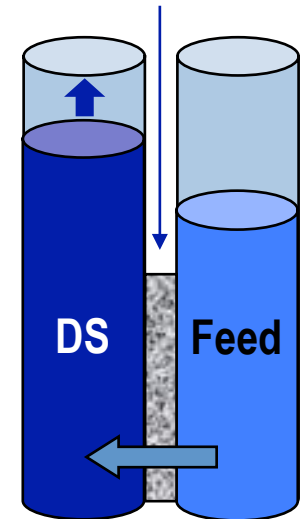

**Figure 2.**

**Hypothesis:** Low concentration of mixed solute DS will be able to reduce RSF while maintaining a high water flux compared to the commonly used NaCl DS

**Materials:**

Membrane: TFC

Solutes tested: NaCl, MgCl<sub>2</sub>, MgSO<sub>4</sub>, sodium acetate – NaAce, sodium citrate – NaCit

Mixed Salt: The osmotic pressure of NaCl at 1 M concentration was used to create mixed saline solution. 5% of MgCl<sub>2</sub> indicates that MgCl<sub>2</sub> contributes 5% of the 1 M osmotic pressure, NaCl contributes the remaining osmotic pressure.

**Methods:**

Each mixed salt solution would run for two hours in the FO Bench, **Fig 3**. Blue lines being Feed and red being DS.

**Results & Conclusions:**

- Mixed salt solutions are able to improve FO process
- Low percentage of mixed solutions provide lower RSF while **Fig 4b**. maintaining high water flux, **Fig 4a**.

**Figure 3.**

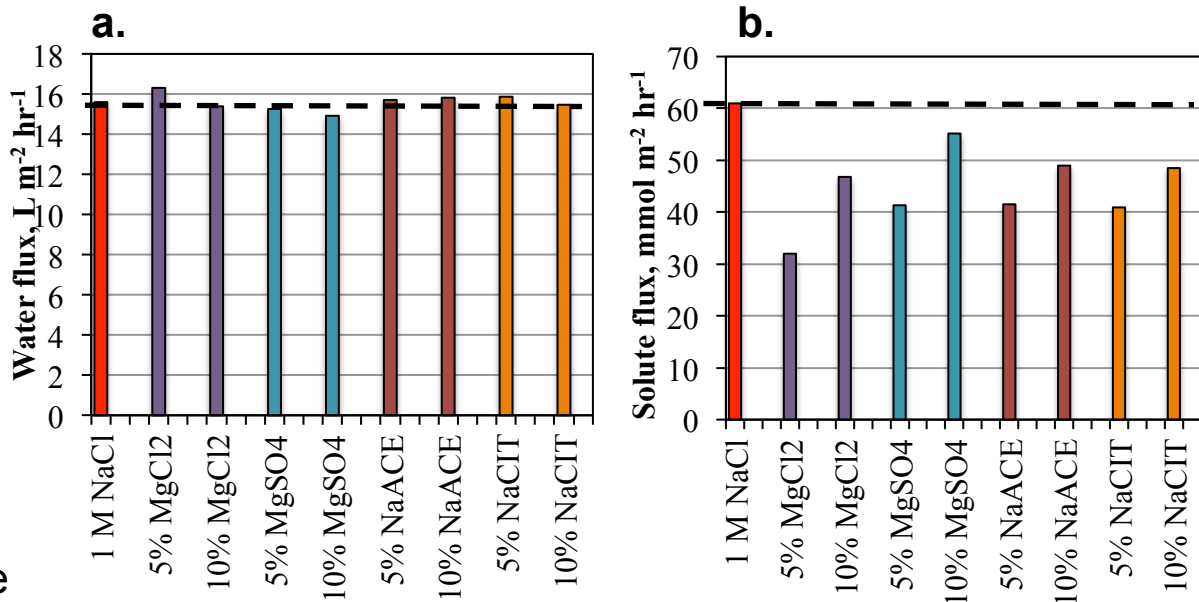
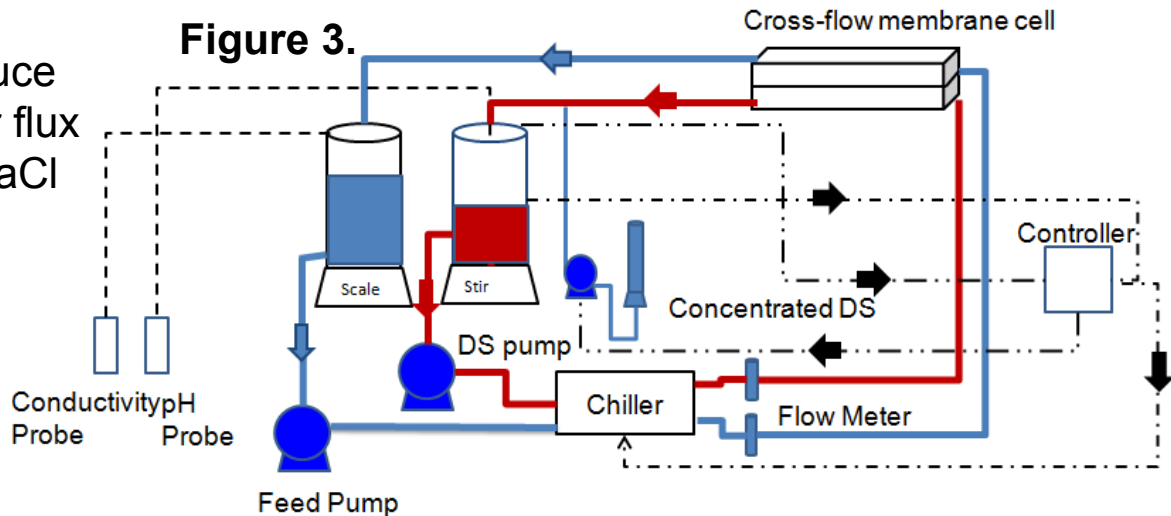

**Figure 4.**