



United States
Environmental Protection
Agency

Office of
Solid Waste
Washington, DC 20460

November 2003

RCRAINFO
FILE SPECIFICATION GUIDE
2003 HAZARDOUS WASTE
REPORT SUBMISSIONS



TABLE OF CONTENTS

	<u>Page</u>
1.0 INTRODUCTION	4
1.1 Overview of Document	4
1.2 Intended Audience.....	4
1.3 Hazardous Waste Report Forms.....	5
1.4 Data Files	5
1.5 Questions/Comments	6
2.0 CHANGES FROM PREVIOUS CYCLES.....	7
2.1 Data Collection Changes.....	7
2.2 Changes to the File Specification Standards	7
2.3 Changes to Data Element Edits	7
3.0 DATA SUBMISSION OVERVIEW	9
3.1 Data Requirements	9
3.2 Data Submission.....	9
3.3 Amount of Data in a Single Submission	10
3.4 States/Regions not using the <i>2003 Hazardous Waste Report, Instructions and Forms</i>	10
3.4.1 Identify Sites	11
3.4.2 Access Equivalent Data.....	11
3.4.3 Data Quality/Equivalency	12
3.4.4 Write Translated Data to Flat Files	12
3.4.5 Generating a Control File.....	13
4.0 TECHNICAL SPECIFICATIONS	14
4.1 Include in National Report Flags	14
4.2 State Generator Status	14
4.3 Rules and Format Conventions Required for Data Flat Files.....	14
4.3.1 Alphanumeric Fields	14
4.3.2 Integer Fields.....	15
4.3.3 Fixed Decimal Fields	15
4.3.4 Sequence Number Fields.....	16
4.3.5 Negative Numbers.....	16
4.4 Indicating Don't Know (DK) and Not Applicable (NA)	16
4.5 Record Termination.....	16
4.6 Empty Fields	16
4.7 Flat File Hierarchy	16
4.8 Confidential Business Information (CBI)	16
APPENDIX A - Required Data Elements	A-1
REQUIRED FIELDS FOR FLAT FILE SI1	A-1
REQUIRED FIELDS FOR FLAT FILE SI2	A-2
REQUIRED FIELDS FOR FLAT FILE SI6	A-3
REQUIRED FIELDS FOR FLAT FILE SI7	A-3
REQUIRED FIELDS FOR FLAT FILE SI9	A-3
REQUIRED FIELDS FOR FLAT FILE GM1	A-4
REQUIRED FIELDS FOR FLAT FILE GM2 OR GM3.....	A-4
REQUIRED FIELDS FOR FLAT FILE GM4	A-5
REQUIRED FIELDS FOR FLAT FILE GM5	A-5
REQUIRED FIELDS FOR FLAT FILE WR1	A-6
REQUIRED FIELDS FOR FLAT FILE WR2 OR WR3.....	A-6

TABLE OF CONTENTS

	<u>Page</u>
APPENDIX B - Flat File Specifications.....	B-1
B.1 Key For Flat File Tables.....	B-1
B.2 Flat File Naming Convention.....	B-1
B.3 Flat Files.....	B-2
FLAT FILE ID# - CTL.....	B-2
FLAT FILE ID# - SI1.....	B-3
FLAT FILE ID# - SI2.....	B-6
FLAT FILE ID# - SI3.....	B-8
FLAT FILE ID# - SI4.....	B-9
FLAT FILE ID# - SI5.....	B-10
FLAT FILE ID# - SI6.....	B-11
FLAT FILE ID# - SI7.....	B-12
FLAT FILE ID# - SI8.....	B-13
FLAT FILE ID# - SI9.....	B-14
FLAT FILE ID# - GM1.....	B-16
FLAT FILE ID# - GM2.....	B-18
FLAT FILE ID# - GM3.....	B-19
FLAT FILE ID# - GM4.....	B-20
FLAT FILE ID# - GM5.....	B-21
FLAT FILE ID# - WR1.....	B-22
FLAT FILE ID# - WR2.....	B-24
FLAT FILE ID# - WR3.....	B-25
FLAT FILE ID# - OI1.....	B-26
APPENDIX C - Data Assessment Edits.....	C-1
C.1 Generic Data Edits.....	C-1
C.2 Control File Edits.....	C-2
C.3 Site Identification Form Edits.....	C-3
C.4 Form GM Edits.....	C-9
C.5 Form WR Edits.....	C-12
APPENDIX D - Hazardous Waste Report Annotated Forms.....	D-1
APPENDIX E - Flat File Hierarchy.....	E-1
APPENDIX F - State Postal Codes.....	F-1

1.0 INTRODUCTION

This document describes the file specifications for reporting data for the 2003 Hazardous Waste Report (also called the Biennial Report). The material in this guide covers submissions by States and Regions to EPA Headquarters (HQ). The file specifications in this guide are not intended to be used to cover submissions by individual reporting sites. Also, this guide is only intended to specify the file and data formats for the submission and is not intended to cover any procedural or EPA programmatic issues.

This document is designed to be used in conjunction with the *2003 Hazardous Waste Report, Instructions and Forms*, EPA Form 8700-13A/B that is referenced throughout this document. You should have a complete copy of the *2003 Hazardous Waste Report, Instructions and Forms* in your possession while using this guide. Copies of the *2003 Hazardous Waste Report, Instructions and Forms* are available at <http://www.epa.gov/epaoswer/hazwaste/data/#brs>.

1.1 Overview of Document

The *File Specification Guide for 2003 Biennial Report Hazardous Waste Submissions* is divided into four sections:

Section 1 (Introduction) defines the intended audience for this guide, offers a brief description of the forms contained in the *2003 Hazardous Waste Report, Instructions and Forms*, and describes the general purpose and outline of this document.

Section 2 (Changes from Previous Cycles) outlines the major changes to the file specifications from previous Biennial Report cycles.

Section 3 (Data Submission Overview) describes the overall characteristics for a data submission.

Section 4 (Technical Specifications) discusses the technical details of the data files and programs necessary for data submission.

Several appendices are included with this document. These appendices provide background material as well as detailed technical information necessary to properly prepare file submissions.

1.2 Intended Audience

The intended audience for this guide is any State or EPA Region that is using its own software and procedures to extract hazardous waste data from a State or Regional system for submission to EPA HQ for inclusion in the RCRAInfo database for the 2003 Hazardous Waste Report; or any commercial software vendor who is preparing software for use/purchase by States and Regions for preparation of State or Regional submission of data for the 2003 Hazardous Waste Report.

(Note: States or Regions who use a data collection instrument different than the *Hazardous Waste Report, Instructions and Forms* developed by EPA HQ are called translators. This guide will serve as guidance for both translators and commercial software vendors.)

This document was written assuming the reader 1) is familiar with the *2003 Hazardous Waste Report, Instructions and Forms* and 2) understands basic computer concepts and terminology.

1.3 Hazardous Waste Report Forms

The *2003 Hazardous Waste Report, Instructions and Forms* document captures information on the following forms:

RCRA Subtitle C Site Identification Form

The Site Identification Form collects information on the site completing the Biennial Report forms package. The form is divided into thirteen items, twelve of which must be completed for the Hazardous Waste Report. States and Regions submit Site ID form information via the SI1, SI2, SI3, SI4, SI5, SI6, SI7, and SI9 flat files.

Note: The SI8 flat file allows implementers to include State specific activities in their Biennial Report submission. This information is not found on the RCRA Subtitle C Site Identification Form, but rather is implementer defined to meet the State's regulatory requirements.

Form GM

Form GM is for reporting on-site hazardous waste generation, management, and off-site shipment. Form GM is divided into three sections that document 1) the source, characteristics, and quantity of hazardous waste generated; 2) the quantity of hazardous waste managed on-site along with the management method used; and 3) the quantity of hazardous waste shipped off-site for treatment, disposal, or recycling along with the off-site management method used. States and Regions submit GM form information via the GM1, GM2, GM3, GM4, and GM5 flat files.

Form WR

Form WR identifies hazardous wastes that were received from other hazardous waste sites and the method(s) used to manage them. Form WR is divided into three identical parts (i.e., waste blocks), labeled Waste 1, Waste 2, and Waste 3, that collect information on the quantities and characteristics of each hazardous waste received from an off-site source during 2003 and managed on-site. States and Regions submit WR form information via the WR1, WR2, and WR3 flat files.

Form OI

Form OI documents the names and addresses of off-site installations and transporters. OI information is not loaded into the RCRAInfo database, but a file specification has been included to facilitate data sharing.

1.4 Data Files

Information gathered from the Hazardous Waste Report is submitted to EPA HQ via a series of flat files. Each form contains information that relates to the form in a one-to-one (1:1) relationship (e.g., Form GM, Section 1, Block D, source code). These data elements are captured in the primary flat file for that form (e.g., SI1, GM1, and WR1). Information that relates to the form in a many-to-one (*n*:1) relationship (e.g., Form GM, Section 1, Block B, EPA hazardous waste codes) is captured in secondary flat files (e.g., GM2-GM5, WR2-WR3).

The remainder of this document describes in detail the steps necessary to ensure a successful data submission including identifying which sites should be reported, the types of files that must be included with each submission, and technical aspects of the file creation process.

1.5 Questions/Comments

Questions about this document should be directed to the RCRAInfo help desk at rcrainfo.help@epa.gov. Questions submitted to the help desk must only concern the file specification for submission of data from the States or EPA Regions to the RCRAInfo database. Questions on submissions of data by individual sites should be directed to appropriate State or EPA Regional personnel.

2.0 CHANGES FROM PREVIOUS CYCLES

2.1 Data Collection Changes

The EPA has made modifications to the Hazardous Waste Report for the 2003 reporting cycle. For further details on these changes, please refer to page 2 of the *2003 Hazardous Waste Report, Instructions and Forms*.

2.2 Changes to the File Specification Standards

The 2003 flat file specifications are being modified to reflect the current forms. Specific changes to the flat file definitions include:

- CTL - Added BR Cycle Year
- SI1 - Added State District as a non-required field
- SI8 - State Activity Type field length changed from 1 character to 5 characters
- GM1 - Added On-Site Management as a required field
- GM1 - Added Off-Site Shipment as a required field

2.3 Changes to Data Element Edits

This section shows changes in the edits to data elements. These edit changes were necessary to comply with the 2003 Hazardous Waste Report, Instructions and Forms and/or to ensure correctness of the data.

- CTL - The control file name must be named ssCTLnnn.FIL where ss is the state postal code and nnn is the Julian date when the file was created.
- SI1 - If the submittal reason is Hazardous Waste Report, the handler must already exist in RCRAInfo
- SI1 - Site Land Type is required
- SI1 - County Name must be a valid value in LU_COUNTY
- SI1 - Mailing State must not be provided if the mailing address is not within the United States
- SI1 - Mailing Country must be a valid value in LU_COUNTRY
- SI1 - Transporter Activity is required and allowed values are 'Y' and 'N'
- SI1 - Recycler Activity is required and allowed values are 'Y' and 'N'
- SI1 - Small Quantity On-Site Burner Exemption is required and allowed values are 'Y' and 'N'
- SI1 - Smelting, Melting, Refining Furnace Exemption is required and allowed values are 'Y' and 'N'
- SI1 - Underground Injection Control is required and allowed values are 'Y' and 'N'
- SI2 - Large Quantity Generator of Batteries is required and allowed values are 'Y' and 'N'
- SI2 - Large Quantity Accumulator of Batteries is required and allowed values are 'Y' and 'N'
- SI2 - Large Quantity Generator of Pesticides is required and allowed values are 'Y' and 'N'
- SI2 - Large Quantity Accumulator of Pesticides is required and allowed values are 'Y' and 'N'
- SI2 - Large Quantity Generator of Thermostats is required and allowed values are 'Y' and 'N'
- SI2 - Large Quantity Accumulator of Thermostats is required and allowed values are 'Y' and 'N'
- SI2 - Large Quantity Generator of Lamps is required and allowed values are 'Y' and 'N'
- SI2 - Large Quantity Accumulator of Lamps is required and allowed values are 'Y' and 'N'
- SI2 - Destination Facility for Universal Waste is required and allowed values are 'Y' and 'N'
- SI2 - Used Oil Transporter is required and allowed values are 'Y' and 'N'
- SI2 - Used Oil Transfer Facility is required and allowed values are 'Y' and 'N'
- SI2 - Used Oil Processor is required and allowed values are 'Y' and 'N'
- SI2 - Used Oil Refiner is required and allowed values are 'Y' and 'N'

- SI2 - Off-Specification Used Oil Burner is required and allowed values are 'Y' and 'N'
- SI2 - Used Oil Fuel Marketer Who Directs Shipment of Off-Specification Used Oil to Off-Specification Used Oil Burner is required and allowed values are 'Y' and 'N'
- SI2 - Used Oil Fuel Marketer Who First Claims the Used Oil Meets the Specifications is required and allowed values are 'Y' and 'N'
- SI6 - NAICS code must be a valid value in LU_NAICS
- SI7 - Certification date must be greater than or equal to January 1, 2004 and less than today
- SI9 - Current Owner/Operator information required for Submittal Reason = 'R' or 'B'
- GM1 - Added source codes G27, G63, G64, G65, G66, G67, G68, G69, G70, G71, G72, G73, G74, G75
- GM1 - Deleted source code G62
- GM1 - The generated quantity must be > 0 and less than 99,999,999,998.999999 or equal to 0
- GM1 - The management method must be blank unless the source code = G25
- GM1 - Deleted RCRA-Radioactive Mixed flag
- GM1 - On-site management indicator must equal 'Y' or 'N'
- GM1 - If the on-site management indicator equals 'Y' then GM5 information must be provided
- GM1 - If the on-site management indicator equals 'N' then GM5 information must not be provided
- GM1 - Off-site shipment indicator must equal 'Y' or 'N'
- GM1 - If the off-site shipment indicator equals 'Y' then GM4 information must be provided
- GM1 - If the off-site shipment indicator equals 'N' then GM4 information must not be provided
- GM4 - The shipped quantity must be > 0 and less than 99,999,999,998.999999
- GM5 - The managed quantity must be > 0 and less than 99,999,999,998.999999
- WR1 - The received quantity must be > 0 and less than 99,999,999,998.999999
- WR1 - Deleted RCRA-Radioactive Mixed flag

3.0 DATA SUBMISSION OVERVIEW

3.1 Data Requirements

Data collected via the *2003 Hazardous Waste Report, Instructions and Forms* may or may not be required to be included in the Hazardous Waste Report submission. For the purposes of this document, “required” refers to data elements that must be provided and cannot have a value of blank. The required data elements are listed in Appendix A.

States and Regions are encouraged to provide as much data (required or not) as possible. This information enhances the analytical usefulness of the Hazardous Waste Report data within RCRAInfo. Specifically, non-required data elements of interest include form codes for all records contained in the GM1 and WR1 files.

State, Regional, and commercial software packages must provide data for required data elements. Flat files containing required data elements include:

- Form Site ID data (RCRA Subtitle C Site Identification Form):
Flat Files SI1, SI2, SI6, SI7, and SI9
- Form GM data (Waste Generation and Management):
Flat Files GM1, GM2, GM4, and GM5
- Form WR data (Waste Received from Off-site):
Flat Files WR1 and WR2

All data elements must be properly formatted and meet required data quality standards to be loaded into RCRAInfo. The data quality standards for these elements are presented in Appendix C.

The Hazardous Waste Report data submission must also include a control file for proper loading into the RCRAInfo database. The control file specifies each flat file to be loaded and the number of records included in the flat file.

Appendix B contains the flat file specifications for all files (including the control file) needed to produce the Hazardous Waste Report data submission.

3.2 Data Submission

It is the responsibility of the State, Regional, or commercial software package to produce a complete set of correctly formatted files of a given State for inclusion in the RCRAInfo database. The RCRAInfo application can only accommodate submissions containing all data for a given State, that is, data for a single site cannot be loaded into RCRAInfo.

Flat files are transferred to the EPA Unix server via the RCRA Central Data Exchange (CDX) application in accordance with the Memorandum of Understanding between the Region and the State. The data is transferred to the EPA in the form of Windows-compatible ZIP files. The RCRAInfo File Transfer Process extracts the files from these zip files and stores the data in Oracle database “staging” records for further processing. The RCRA staging process is designed to run as a background process that continuously looks for files to process. Therefore, there is no user interaction required once the environment is configured and the process is started.

CDX provides an interface for submitters to upload a ZIP file from their local file location (commonly the C:/ drive) to the CDX/RCRAInfo environments. The uploaded file must be in the form of a ZIP file and must contain a mandatory control file that lists the names of the other files in the ZIP file. The ZIP file must conform to PKWARE's (de facto) compression standard. The EPA has tested and approved two compression utilities for use by submitters. They are available for download at <http://www.epa.gov/cdx/test/zipintro.htm>.

The submitter must have a valid CDX user ID and password as well as a valid RCRAInfo (pre-production) user ID and password. CDX user ID and passwords may be obtained at <http://cdx.epa.gov> or at 888-890-1995. In addition, the Biennial Report Load Implementor of Record setting within RCRAInfo must be appropriately set (Region or State).

3.3 Amount of Data in a Single Submission

Each data submission must contain **ALL** data for the State for which data is being submitted. Each data submission will overwrite **ALL** existing 2003 Hazardous Waste Report data for the State in the RCRAInfo database.

3.4 States/Regions not using the 2003 Hazardous Waste Report, Instructions and Forms

The information contained in this guide is equally applicable to States and Regions who use a different data collection package than the *2003 Hazardous Waste Report, Instructions and Forms*. Translators are required to provide data equivalent to that collected by the *2003 Hazardous Waste Report, Instructions and Forms* (required data elements). The following information is provided to help translators become familiar with the steps to ensure a successful data submission:

- Identify all sites for which information is to be translated.
- Access information that is equivalent to the *2003 Hazardous Waste Report* data.
- Validate that the equivalent data conforms to the appropriate data quality standards.
- Write translated data to appropriate flat files.
- Generate a control file for the translated flat files.

3.4.1 Identify Sites

The State/Region must submit information for sites required to file the *2003 Hazardous Waste Report, Instructions and Forms*. The criteria that defines these sites is presented on page iii of the *2003 Hazardous Waste Report, Instructions and Forms* under “Sites Required to File the Hazardous Waste Report.” States and Regions are not precluded from submitting information for sites not required to file the *2003 Hazardous Waste Report, Instructions and Forms*.

3.4.2 Access Equivalent Data

The required data elements for the sites being reported must be provided (see Appendix A for a complete list of required data elements). The translator State/Region must identify in their system the data elements and relationships equivalent to the data elements/relationships represented by the flat file specifications provided in Appendix B.

The Form GM, Form WR, and Form OI allow for multiple form submissions by a handler. Translator States/Regions must also accommodate multiple “forms” by a handler as follows:

Form GM

Form GM collects data associated with a single reported waste. Translators must provide records in the GM1 - GM5 files for each waste generated or managed during the reporting cycle. Thus, each page number for the GM flat file records represents a **single** reported waste. All "GM" flat file records containing data associated with the same waste reported for the same EPA ID will have the same page number. Page number takes the value of "00001" for the first reported waste (Form GM) and is incremented by one (1) with each following reported waste. (Note: The instructions on assignment of page number for translators are different than for those States/Regions/commercial software vendors supporting the *2003 Hazardous Waste Report, Instructions and Forms*. For vendors supporting the *2003 Hazardous Waste Report, Instructions and Forms*, page number should be the same as the number assigned by the respondent to the actual form.)

Form WR

Form WR collects data associated with each reported waste received from off-site. Translators must provide records in the WR1 - WR3 files for each waste received from off-site. All "WR" flat file records containing data associated with the same received waste reported for the same handler will have the same page number. Page number takes the value of "00001" for the first received waste (Form WR) and is incremented by one (1) with each separate received waste reported. The sub-page number for Form WR data must always be assigned the value of “1”. (Note: The instructions on assignment of page number and sub-page number for translators are different than for those States/Regions/commercial software vendors supporting the *2003 Hazardous Waste Report, Instructions and Forms*. For vendors supporting the *2003 Hazardous Waste Report, Instructions and Forms*, page number and sub-page number should be the same as the number assigned by the respondent to the actual form. Sub-page number is ‘1’ for the waste reported in the “Waste 1” block of the WR form, ‘2’ for the waste reported in the “Waste 2” block of the WR form, and ‘3’ for the waste reported in the “Waste 3” block of the WR form.)

Form OI

Form OI collects data identifying 1) handlers from whom waste was received and to whom waste was shipped and 2) all transporters used to ship waste during the reporting cycle. These source, destination, and transporting entities are identified by their EPA ID, name, and address. The page number for the OI flat file records represents a single handler record. Page number takes the value of "00001" for the first handler record and is incremented by one (1) with each separate handler record reported.

3.4.3 Data Quality/Equivalency

The State/Region's translator data must provide an accurate representation of hazardous waste activity for that State. In addition, the translator's data must pass a minimum set of data edits (see Appendix C) in order to provide information comparable to data gathered with the *2003 Hazardous Waste Report, Instructions and Forms* and to be properly loaded into the RCRAInfo database. Data failing to conform to the appropriate data quality edits will result in the entire data submission to RCRAInfo being rejected.

Appendix D contains an annotated copy of the *2003 Hazardous Waste Report* forms showing in which flat file each data element is located. In addition, all codes used in the submission must conform to acceptable data values as specified in Appendix C.

3.4.4 Write Translated Data to Flat Files

Translator States/Regions must extract data from their State/Regional system and re-produce the data in the flat file formats outlined in Appendix B. A complete translation effort may not necessarily include all flat files. For example, a translator submitting Form GM data is not required to include the "GM3" flat file (State waste codes) since it is non-required data. However, the State/Region is encouraged to include in the Hazardous Waste Report data submission all data (required and non-required) that the State/Region currently collects.

The flat file specifications for the Hazardous Waste Report data are based on a series of parent-child relationships. A parent file (i.e., SI1, GM1, WR1) may have one or more child relationships with other flat files (i.e., SI2-SI9, GM2-GM5, WR2-WR3). Child records may not exist without the existence of the parent record (e.g., a record for site XYZ cannot exist in the GM2 file if a corresponding record does not exist in the GM1 file). Appendix E shows the parent-child relationships for all flat files comprising the Hazardous Waste Report data submission.

Data for a site should only be included in the Hazardous Waste Report data submission after all records for that site pass all appropriate edit checks. If a site's data is incomplete, then the site's information must not be included in the State's Hazardous Waste Report data submission. **It is not sufficient to eliminate the data element in error and submit the remainder of the site's data.**

3.4.5 Generating a Control File

The translator must include a “control” file with all Hazardous Waste Report data submissions. The specifications for this file are included in Appendix B. The control file records contain information describing the flat files being submitted. One control file record is created for each submitted flat file. These records **MUST** be in the following order:

SI1, SI2, SI3, SI4, SI5, SI6, SI7, SI8, SI9, GM1, GM2, GM3, GM4, GM5, WR1, WR2, WR3

Exhibit 1. Control File Flat File Order

Note: The control file should contain information **only** on the flat files submitted. If a flat file is not submitted, no information for the file should be placed in the control file. The OI1 flat file should never be included in the control file because this form is not to be submitted to the RCRAInfo database.

4.0 TECHNICAL SPECIFICATIONS

This section contains the standards that must be met when producing flat files for the Hazardous Waste Report data submission. Failure to meet these specifications will result in the rejection of the flat files and failure to load the data into the RCRAInfo database.

4.1 Include in National Report Flags

SI1, GM1, and WR1 file specifications include a field labeled INCLUDE_IN_NATIONAL_REPORT. The purpose of this field is to allow implementers to submit additional Hazardous Waste Report data (for purposes of data sharing) but keep that data from being included in the National Biennial Hazardous Waste Report. The field is defined as follows: If the INCLUDE_IN_NATIONAL_REPORT flag in the SI1 file is 'N' (No), then all the INCLUDE_IN_NATIONAL_REPORT flags for the site must also equal 'N' (No) else the submission will be in error. If the INCLUDE_IN_NATIONAL_REPORT flag in the SI1 file is 'Y' (Yes), implementers may set the flag in the GM1 and WR1 file as either 'Y' (Yes) or 'N' (No) to indicate whether that particular waste should be included in the National Biennial Hazardous Waste Report. It is anticipated that many implementers will default the value for these flags to 'Y' (Yes) in all cases, however the specific implementation of how these flags are populated is determined by the implementer.

4.2 State Generator Status

Implementers are required to furnish both the State specific generator status and the Federal generator status for each site in their submission. Appropriate fields are included in the SI1 file specification for this purpose. It is anticipated that many States whose regulations closely match the federal regulations, either by reference or by inclusion, will choose for the values of these fields to be the same. The method to populate these fields is determined by the implementer, however both fields must be provided or the submission will be rejected.

4.3 Rules and Format Conventions Required for Data Flat Files

The following sections detail the correct field formats for the data in the flat files.

4.3.1 Alphanumeric Fields

Alphanumeric fields are identified in Appendix B as Data Type "A" fields. Data Type "A" fields must be left-justified with all trailing spaces filled with the space character (i.e., ASCII HEX 0x20 or ASCII Decimal 32).

Valid characters for alphanumeric fields are limited to:

~ ! # \$ % ^ * () _ + ` - \ = : ; ? , . / ' " @ & [] | 1234567890ABCDEFGHIJKLMNOPQRSTUVWXYZ

Invalid characters for alphanumeric fields include:

{ } < >

If the "<" or ">" symbols are used to indicate less than or greater than, it is recommended that these symbols be replaced with "LT" or "GT".

As part of the RCRAInfo load routines, all lowercase letters (a-z) will be converted to uppercase characters (A-Z). Lowercase letters will not cause a submission to be rejected, however the lowercase letters will be converted to uppercase characters.

4.3.2 Integer Fields

Integer fields are identified in Appendix B as Data Type "I" fields.

Allowed values for integer fields are numbers 0-9 and the space character (ASCII Hex 0x20 or ASCII Decimal 32).

Examples of incorrect and correct entries for an integer field defined with a length of five (5) are presented in Exhibit 2 below.

INCORRECT	CORRECT
1A	1
10,000	10000
750.25	750

Exhibit 2. Incorrect and Correct Integer Entries

4.3.3 Fixed Decimal Fields

Fixed place decimal fields are identified in Appendix B as Data Type "D" fields.

For all "D" field entries, the flat file specifications indicate the number of digits that the data element is allowed before the decimal and after the decimal. For example, D11.6 indicates that the number may have up to 11 digits before the decimal and 6 digits after the decimal (9999999999.999999). The field length includes the decimal character.

Allowed values for fixed decimal fields are numbers 0-9, the decimal character ".", and the space character (ASCII Hex 0x20 or ASCII Decimal 32).

Although some data blocks on the *2003 Hazardous Waste Report, Instructions and Forms* provide for only one decimal place, the translator flat files may allow additional decimal places to be represented in "D" fields. Exhibit 3 shows incorrect and correct entries in a type "D5.2" field.

INCORRECT	CORRECT
10,032.1	10032.10
10,032A	10032

Exhibit 3. Incorrect and Correct Fixed Decimal Entries

4.3.4 Sequence Number Fields

Some of the files in Appendix B require a sequence number to be provided for each record. The SI6 file, for example, requires a sequence number (NAICS_SEQ) for the NAICS codes. The sequence number is needed for data elements, such as the NAICS code, which may have more than one value. The sequence number should be assigned the value "1" for the first occurrence of the sequenced data element for the EPA ID and should then be incremented by one with each successive occurrence of that same EPA ID.

4.3.5 Negative Numbers

Negative numbers are not allowed in the data submission.

4.4 Indicating Don't Know (DK) and Not Applicable (NA)

The *2003 Hazardous Waste Report, Instructions and Forms* document does not allow the use of "Don't Know" (DK) or "Not Applicable" (NA). Flat files cannot contain any values indicating "Don't Know" or "Not Applicable."

4.5 Record Termination

Each flat file record must be terminated by a line feed character (ASCII Hex 0x0A or ASCII Decimal 010), or a carriage return character (ASCII Hex 0x0D or ASCII Decimal 013) followed by a line feed character.

4.6 Empty Fields

For fields that require no response, the field should be filled with the space character (i.e., blanks).

4.7 Flat File Hierarchy

Appendix E shows the flat file hierarchy for the Hazardous Waste Report data submission. Files connected by lines have a parent-child relationship. The file identified at the left terminus of a line is the parent. The file identified at the right terminus of a line is the child. Each record with a unique EPA ID in a child flat file must have at least one corresponding record in the parent flat file. When a parent flat file distinguishes records using more than one key, it is the combination of the keys that identifies uniqueness. For example, the "GM" series flat files use two keys (Handler ID and GM Page Number) to identify each "waste" being reported for a site. Thus, for each unique occurrence of the combined keys (Handler ID and GM Page Number) in the GM2 flat file, there must be a corresponding record in the GM1 file with the same values for the entire key.

4.8 Confidential Business Information (CBI)

Under existing RCRA statutes, sites may claim that certain items of information submitted as part of their Hazardous Waste Report contain Confidential Business Information (CBI). The procedures for handling CBI can be found in *Procedures for Handling RCRA Confidential Business Information* (available from the EPA HQ RCRA Document Control Officer). A subset of these procedures is documented in *Procedures for Handling RCRA Confidential Business Information Submitted for the Biennial Report*. (Copies of these documents can be requested from the RCRAInfo help desk at rcrainfo.help@epa.gov). In brief, it is not allowable to mingle CBI data with non-CBI data. In addition, CBI data must be handled on a secure computer (either a computer that is kept in a secure environment or a computer that uses

removable media where the media is kept in a secure environment). CBI data must be submitted separately from non-CBI data using data handling methods outlined in the *Procedures for Handling RCRA Confidential Business Information* documentation.

In previous Biennial Report cycles, some States/Regions that have received CBI have masked the CBI data (in other words, changed the CBI data so it no longer is CBI). This practice is not a requirement of EPA HQ, but as long as the masking is acceptable to the site and the implementer, and the data meets the minimum edit standards as detailed in the appendices, this solution is acceptable.

APPENDIX A

Required Data Elements

APPENDIX A - Required Data Elements

For the purposes of this document, “required” refers to data elements that must be provided that cannot have a value of blank.

REQUIRED FIELDS FOR FLAT FILE SII

FIELD NAME	DESCRIPTION	FORM LOCATION
HANDLER_ID	EPA Identification Number	SI-2
SUBMITTAL_REASON	Reason for Submittal	SI-1
NAME	Name	SI-3
LOCATION_STREET1	Location Street 1	SI-4
LOCATION_CITY	Location City	SI-4
COUNTY_NAME	County Name	SI-4
LOCATION_STATE	Location State	SI-4
LOCATION_ZIP	Location Zip Code	SI-4
MAIL_STREET1	Mailing Street 1	SI-7
MAIL_CITY	Mailing City	SI-7
MAIL_STATE*	Mailing State	SI-7
MAIL_ZIP	Mailing Zip Code	SI-7
LAND_TYPE	Site Land Type	SI-5
CONTACT_FIRST_NAME	Contact First Name	SI-8
CONTACT_LAST_NAME	Contact Last Name	SI-8
CONTACT_PHONE	Contact Phone Number	SI-8
STATE_GENERATOR_STATUS	State Specific Generator Status	
GENERATOR_ACTIVITY	Generator Activity	SI-10-A-1
IMPORTER_ACTIVITY	U.S. Importer of Hazardous Waste	SI-10-A-1
MIXED_WASTE_GENERATOR	Mixed Waste (hazardous and radioactive) Generator	SI-10-A-1
TRANSPORTER_ACTIVITY	Transporter of Hazardous Waste	SI-10-A-2
TSD_ACTIVITY	Treater, Storer, or Disposer of Hazardous Waste	SI-10-A-3
RECYCLER_ACTIVITY	Recycler of Hazardous Waste	SI-10-A-4
HWFUEL_ONSITE_BURNER_EXEMPT	Small Quantity On-Site Burner Exemption	SI-10-A-5

FIELD NAME	DESCRIPTION	FORM LOCATION
HWFUEL_FURNACE_EXEMPT	Smelting, Melting, Refining Furnace Exemption	SI-10-A-5
UNDERGROUND_INJECTION_ACTIVITY	Underground Injection Control	SI-10-A-6
INCLUDE_IN_NATIONAL_REPORT	Include this Information in the National Hazardous Waste Report	

* Required if MAIL_COUNTRY is blank or MAIL_COUNTRY = 'UNITED STATES'.

REQUIRED FIELDS FOR FLAT FILE SI2

FIELD NAME	DESCRIPTION	FORM LOCATION
HANDLER_ID	EPA Identification Number	SI-2
GEN_BATTERIES	Large Quantity Generator of Batteries	SI-10-B-1-A
ACC_BATTERIES	Large Quantity Accumulator of Batteries	SI-10-B-1-A
GEN_PESTICIDES	Large Quantity Generator of Pesticides	SI-10-B-1-B
ACC_PESTICIDES	Large Quantity Accumulator of Pesticides	SI-10-B-1-B
GEN_THERMOSTATS	Large Quantity Generator of Thermostats	SI-10-B -1-C
ACC_THERMOSTATS	Large Quantity Accumulator of Thermostats	SI-10-B-1-C
GEN_LAMPS	Large Quantity Generator of Lamps	SI-10-B-1-D
ACC_LAMPS	Large Quantity Accumulator of Lamps	SI-10-B-1-D
UNIVERSAL_WASTE_DEST_FACILITY	Destination Facility for Universal Waste	SI-10-B-2
USED_OIL_TRANSPORTER	Used Oil Transporter	SI-10-C-1-A
USED_OIL_TRANSFER_FACILITY	Used Oil Transfer Facility	SI-10-C-1-B
USED_OIL_PROCESSOR	Used Oil Processor	SI-10-C-2-A
USED_OIL_REFINER	Used Oil Refiner	SI-10-C-2-B
USED_OIL_BURNER	Off-Specification Used Oil Burner	SI-10-C-3
USED_OIL_MARKET_BURNER	Used Oil Fuel Marketer Who Directs Shipment of Off-Specification Used Oil to Off-Specification Used Oil Burner	SI-10-C-4-A
USED_OIL_SPEC_MARKETER	Used Oil Fuel Marketer Who First Claims the Used Oil Meets the Specifications	SI-10-C-4-B

REQUIRED FIELDS FOR FLAT FILE SI6

FIELD NAME	DESCRIPTION	FORM LOCATION
HANDLER_ID	EPA Identification Number	SI-2
NAICS_SEQ	NAICS Sequence Number	
NAICS_CODE	North American Industry Classification System Code	SI-6

REQUIRED FIELDS FOR FLAT FILE SI7

FIELD NAME	DESCRIPTION	FORM LOCATION
HANDLER_ID	EPA Identification Number	SI-2
CERT_SEQ	Certification Sequence Number	
CERT_FIRST_NAME	Certification First Name	SI-13
CERT_LAST_NAME	Certification Last Name	SI-13
CERT_TITLE	Certification Title	SI-13
CERT_SIGNED_DATE	Date Certification Was Signed	SI-13

REQUIRED FIELDS FOR FLAT FILE SI9

NOTE: INFORMATION MUST BE PROVIDED FOR BOTH CURRENT OWNER AND CURRENT OPERATOR

FIELD NAME	DESCRIPTION	FORM LOCATION
HANDLER_ID	EPA Identification Number	SI-2
OWNER_OPERATOR_SEQ_NO	Owner/Operator Sequence Number	
OWNER_OPERATOR_INDICATOR	Owner/Operator Indicator	
OWNER_OPERATOR_NAME	Site's Legal Owner/Operator	SI-9-A, SI-9-B
OWNER_OPERATOR_DATE	Date Became Owner/Operator	SI-9-A, SI-9-B
OWNER_OPERATOR_TYPE	Owner/Operator Type	SI-9-A, SI-9-B

REQUIRED FIELDS FOR FLAT FILE GM1

FIELD NAME	DESCRIPTION	FORM LOCATION
HANDLER_ID	EPA Identification Number	SI-2
HZ_PG	Page Number	
UNIT_OF_MEASURE	Unit of Measure	GM-1-G
WST_DENSITY*	Density	GM-1-G
DENSITY_UNIT_OF_MEASURE*	Density Unit of Measure	GM-1-G
ORIGIN_MANAGEMENT_METHOD**	Origin management method for source code G25	GM-1-D
SOURCE_CODE	Source Code	GM-1-D
GEN_QTY	Quantity Generated in Reporting Year	GM-1-F
INCLUDE_IN_NATIONAL_REPORT	Include Information in the National Hazardous Waste Report	
ON_SITE_MANAGEMENT	Was any of this waste managed on-site during 2003	GM-2
OFF_SITE_SHIPMENT	Was any of this waste shipped off-site in 2003 for treatment, disposal, or recycling	GM-3-A

* Required only if the unit of measure = 5 (gallons), 6 (liters), or 7 (cubic yards).

** Required only if the source code is G25.

REQUIRED FIELDS FOR FLAT FILE GM2 OR GM3*

FIELD NAME	DESCRIPTION	FORM LOCATION
HANDLER_ID	EPA Identification Number	SI-2
HZ_PG	Page Number	
WASTE_CODE	EPA/State Hazardous Waste Code	GM-1-B / GM-1-C

* For each waste stream, either EPA Hazardous Waste Code information must be provided (GM2) or State Hazardous Waste Code information must be provided (GM3).

REQUIRED FIELDS FOR FLAT FILE GM4*

FIELD NAME	DESCRIPTION	FORM LOCATION
HANDLER_ID	EPA Identification Number	SI-2
HZ_PG	Page Number	
IO_PG_NUM_SEQ	Off-site Sequence Number	GM-3 Site# Block
IO_TDR_ID	EPA ID Number of the Off-Site Facility Shipped To	GM-3-B
IO_TDR_QTY	Total Quantity Shipped to EPA ID in Current Reporting Year	GM-3-D

* If the off-site shipment indicator in GM1 is equal to 'Y' then Off-site Shipment information (GM4) must be provided.

REQUIRED FIELDS FOR FLAT FILE GM5*

FIELD NAME	DESCRIPTION	FORM LOCATION
HANDLER_ID	EPA Identification Number	SI-2
HZ_PG	Page Number	
SYS_PG_NUM_SEQ	On-Site Sequence Number	GM-2 System# Block
MANAGEMENT_METHOD	On-Site Management Method	GM-2
SYS_TDR_QTY	Quantity Treated, Disposed, or Recycled On- site in Current Reporting Year	GM-2

*If the on-site management indicator in GM1 is equal to 'Y' then On-Site Management information (GM5) must be provided.

REQUIRED FIELDS FOR FLAT FILE WR1

FIELD NAME	DESCRIPTION	FORM LOCATION
HANDLER_ID	EPA Identification Number	SI-2
HZ_PG	Page Number	
SUB_PG_NUM	Waste Number	
UNIT_OF_MEASURE	Unit of Measure	WR-F
WST_DENSITY*	Density	WR-F
DENSITY_UNIT_OF_MEASURE*	Density Unit of Measure	WR-F
MANAGEMENT_METHOD	Management Method	WR-H
IO_TDR_ID	Off-site Source EPA ID Number	WR-D
IO_TDR_QTY	Quantity Received in Current Reporting Year	WR-E
INCLUDE_IN_NATIONAL_REPORT	Include Information in the National Hazardous Waste Report	

* Required only if the unit of measure = 5 (gallons), 6 (liters), or 7 (cubic yards).

REQUIRED FIELDS FOR FLAT FILE WR2 OR WR3*

FIELD NAME	DESCRIPTION	FORM LOCATION
HANDLER_ID	EPA Identification Number	SI-2
HZ_PG	Page Number	
SUB_PG_NUM	Waste Number	
WASTE_CODE	EPA/State Hazardous Waste Code	WR-B / WR-C

* For each waste stream, either EPA Hazardous Waste Code information must be provided (WR2) or State Hazardous Waste Code information must be provided (WR3).

APPENDIX B

Flat File Specifications

APPENDIX B - Flat File Specifications

B.1 Key For Flat File Tables

Data Type

A	Alphanumeric
I	Integer
D	Fixed Decimal

B.2 Flat File Naming Convention

Flat files names are constructed in the following manner:

SSFFFNNN.FIL

Where:

SS	=	State Postal Code
FFF	=	Flat file identifier (for example, GM1 or GM2)
NNN	=	Julian Date when file was created

Files must be named using all **uppercase** characters.

Note: The three-character file ID distinguishes each flat file produced during the translation. For example, the correct name for the SI3 file, containing VA data, produced on January 4th, is VASI3004.FIL.

B.3 Flat Files

FLAT FILE ID# - CTL					
Source Form: NA		Description: Name and statistical information for each flat file being submitted			
<p>This file is used to describe the flat files being submitted electronically. There must be one record in the control file for each flat file being submitted. Each CTL record contains a flat file name (field 1), the date the flat file was created in "CCYYMMDD" format (field 2), and the number of records (lines) in the flat file (field 3).</p> <p>When creating the Control File, first list records SI1-SI9, followed by GM1-GM5, followed by WR1-WR3. The control file must never contain entries for file OI1. Only create control records for files that contain one or more records.</p> <p>File name must be in uppercase characters in the following format: SSCTLNNN.FIL where SS = State Postal Code and NNN = Julian Date when file was created.</p>					
Field Number	Starting Column	Field Length	Data Type	Description	Edit Number
1	1	12	A	File Name	CL000, CL010, CL020, CL030
2	13	8	I	Date Created (Format = CCYYMMDD)	CL040
3	21	8	I	Record Count	CL050
4	29	4	I	BR Reporting Cycle Year (2003)	CL060
Total Record Length:		32			

FLAT FILE ID# - SI1

Source Form: Site ID **Description:** Handler Identification, Address, and Hazardous Waste Activities Information

This file must contain one and only one record for each Handler ID reporting. Also, any Handler ID appearing as the key in ANY of the “GM”, “WR”, or “OI” files must also be present in this file.

Key Fields: Handler ID Number (HANDLER_ID). Each record in the SI1 file must contain a unique Handler ID Number.

Note: The SI1 file is REQUIRED. One record must be provided for each handler.

Field No.	Field Name	Starting Column	Field Length	Data Type	Description	Location on Form	Edit Number
1	HANDLER_ID	1	12	A	EPA Identification Number	SI-2	SI000, SI005
2	SUBMITTAL_REASON	13	1	A	Reason for Submittal (As a component of the Hazardous Waste Report = 'R', As a component of the Hazardous Waste Report AND any other reason for submittal = 'B')	SI-1	SI015
3	NAME	14	40	A	Name	SI-3	SI020
4	LOCATION_STREET_NO	54	12	A	Location Street Number	SI-4	
5	LOCATION_STREET1	66	30	A	Location Street 1	SI-4	SI040
6	LOCATION_STREET2	96	30	A	Location Street 2	SI-4	
7	LOCATION_CITY	126	25	A	Location City	SI-4	SI050
8	COUNTY_NAME	151	25	A	County Name	SI-4	SI060
9	LOCATION_STATE	176	2	A	Location State	SI-4	SI070, SI090
10	LOCATION_ZIP	178	14	A	Location Zip Code	SI-4	SI080, SI085
11	MAIL_STREET_NO	192	12	A	Mailing Street Number	SI-7	
12	MAIL_STREET1	204	30	A	Mailing Street 1	SI-7	SI100
13	MAIL_STREET2	234	30	A	Mailing Street 2	SI-7	

FLAT FILE ID# - SI1

Source Form: Site ID **Description:** Handler Identification, Address, and Hazardous Waste Activities Information

This file must contain one and only one record for each Handler ID reporting. Also, any Handler ID appearing as the key in ANY of the “GM”, “WR”, or “OI” files must also be present in this file.

Key Fields: Handler ID Number (HANDLER_ID). Each record in the SI1 file must contain a unique Handler ID Number.

Note: The SI1 file is REQUIRED. One record must be provided for each handler.

Field No.	Field Name	Starting Column	Field Length	Data Type	Description	Location on Form	Edit Number
14	MAIL_CITY	264	25	A	Mailing City	SI-7	SI110
15	MAIL_STATE	289	2	A	Mailing State	SI-7	SI120
16	MAIL_COUNTRY	291	50	A	Mailing Country Name	SI-7	SI140
17	MAIL_ZIP	341	14	A	Mailing Zip Code	SI-7	SI130, SI135
18	LAND_TYPE	355	1	A	Site Land Type (Private = 'P', County = 'C', District = 'D', Federal = 'F', Indian = 'I', Municipal = 'M', State = 'S', Other = 'O', Unchecked = '')	SI-5	SI310
19	CONTACT_FIRST_NAME	356	15	A	Contact First Name	SI-8	SI150
20	CONTACT_MIDDLE_INITIAL	371	1	A	Contact Middle Initial	SI-8	
21	CONTACT_LAST_NAME	372	15	A	Contact Last Name	SI-8	SI160
22	CONTACT_PHONE	387	10	A	Contact Phone Number	SI-8	SI170
23	CONTACT_PHONE_EXT	397	6	A	Contact Phone Number Extension	SI-8	
24	STATE_GENERATOR_STATUS	403	1	A	State Specific Generator Status	SI-10-A-1	SI175
25	GENERATOR_ACTIVITY	404	1	A	Generator Activity (LQG = '1', SQG = '2', CESQG = '3', Not a generator = 'N')	SI-10-A-1	SI180
26	IMPORTER_ACTIVITY	405	1	A	U.S. Importer of Hazardous Waste (Yes = 'Y', No = 'N')	SI-10-A-1	SI460

FLAT FILE ID# - SI1

Source Form: Site ID **Description:** Handler Identification, Address, and Hazardous Waste Activities Information

This file must contain one and only one record for each Handler ID reporting. Also, any Handler ID appearing as the key in ANY of the “GM”, “WR”, or “OI” files must also be present in this file.

Key Fields: Handler ID Number (HANDLER_ID). Each record in the SI1 file must contain a unique Handler ID Number.

Note: The SI1 file is REQUIRED. One record must be provided for each handler.

Field No.	Field Name	Starting Column	Field Length	Data Type	Description	Location on Form	Edit Number
27	MIXED_WASTE_GENERATOR	406	1	A	Mixed Waste (hazardous and radioactive) Generator (Yes = 'Y', No = 'N')	SI-10-A-1	SI470
28	TRANSPORTER_ACTIVITY	407	1	A	Transporter of Hazardous Waste (Yes = 'Y', No = 'N')	SI-10-A-2	SI480
29	TSD_ACTIVITY	408	1	A	Treater, Storer, or Disposer of Hazardous Waste (Yes = 'Y', No = 'N')	SI-10-A-3	SI190
30	RECYCLER_ACTIVITY	409	1	A	Recycler of Hazardous Waste (Yes = 'Y', No = 'N')	SI-10-A-4	SI490
31	HWFUEL_ONSITE_BURNER_EXEMPT	410	1	A	Small Quantity On-Site Burner Exemption (Yes = 'Y', No = 'N')	SI-10-A-5	SI500
32	HWFUEL_FURNACE_EXEMPT	411	1	A	Smelting, Melting, Refining Furnace Exemption (Yes = 'Y', No = 'N')	SI-10-A-5	SI510
33	UNDERGROUND_INJECTION_ACTIVITY	412	1	A	Underground Injection Control (Yes = 'Y', No = 'N')	SI-10-A-6	SI520
34	INCLUDE_IN_NATIONAL_REPORT	413	1	A	Include this Information in the National Hazardous Waste Report (Yes = 'Y', No = 'N')		SI999
35	NOTES	414	240	A	Comments/Notes	SI-12	
36	CONTACT_EMAIL	654	240	A	Contact E-Mail Address		
37	STATE_DISTRICT	894	10	A	State District		
Total Record Length:			903				

FLAT FILE ID# - SI2

Source Form: Site ID **Description:** Handler Universal Waste and Used Oil Activities

This file captures the information contained in Section 10, Block B, Questions 1A - 1D of the Site ID form. This file should contain one and only one record for each Handler ID reporting.

Key Fields: Handler ID Number (HANDLER_ID). Each record in the SI2 file must contain a unique Handler ID Number.

Note: The SI2 file is REQUIRED. One record must be provided for each handler.

Field No.	Field Name	Starting Column	Field Length	Data Type	Description	Location on Form	Edit Number
1	HANDLER_ID	1	12	A	EPA Identification Number	SI-2	SI530
2	GEN_BATTERIES	13	1	A	Large Quantity Generator of Batteries (Yes = 'Y', No = 'N')	SI-10-B-1-A	SI540
3	ACC_BATTERIES	14	1	A	Large Quantity Accumulator of Batteries (Yes = 'Y', No = 'N')	SI-10-B-1-A	SI550
4	GEN_PESTICIDES	15	1	A	Large Quantity Generator of Pesticides (Yes = 'Y', No = 'N')	SI-10-B-1-B	SI560
5	ACC_PESTICIDES	16	1	A	Large Quantity Accumulator of Pesticides (Yes = 'Y', No = 'N')	SI-10-B-1-B	SI570
6	GEN_THERMOSTATS	17	1	A	Large Quantity Generator of Thermostats (Yes = 'Y', No = 'N')	SI-10-B-1-C	SI580
7	ACC_THERMOSTATS	18	1	A	Large Quantity Accumulator of Thermostats (Yes = 'Y', No = 'N')	SI-10-B-1-C	SI590
8	GEN_LAMPS	19	1	A	Large Quantity Generator of Lamps (Yes = 'Y', No = 'N')	SI-10-B-1-D	SI600
9	ACC_LAMPS	20	1	A	Large Quantity Accumulator of Lamps (Yes = 'Y', No = 'N')	SI-10-B-1-D	SI610
10	UNIVERSAL_WASTE_DEST_FACILITY	21	1	A	Destination Facility for Universal Waste (Yes = 'Y', No = 'N')	SI-10-B-2	SI620

FLAT FILE ID# - SI2

Source Form: Site ID **Description:** Handler Universal Waste and Used Oil Activities

This file captures the information contained in Section 10, Block B, Questions 1A - 1D of the Site ID form. This file should contain one and only one record for each Handler ID reporting.

Key Fields: Handler ID Number (HANDLER_ID). Each record in the SI2 file must contain a unique Handler ID Number.

Note: The SI2 file is REQUIRED. One record must be provided for each handler.

Field No.	Field Name	Starting Column	Field Length	Data Type	Description	Location on Form	Edit Number
11	USED_OIL_TRANSPORTER	22	1	A	Used Oil Transporter (Yes = 'Y', No = 'N')	SI-10-C-1-A	SI630
12	USED_OIL_TRANSFER_FACILITY	23	1	A	Used Oil Transfer Facility (Yes = 'Y', No = 'N')	SI-10-C-1-B	SI640
13	USED_OIL_PROCESSOR	24	1	A	Used Oil Processor (Yes = 'Y', No = 'N')	SI-10-C-2-A	SI650
14	USED_OIL_REFINER	25	1	A	Used Oil Re-refiner (Yes = 'Y', No = 'N')	SI-10-C-2-B	SI660
15	USED_OIL_BURNER	26	1	A	Off-Specification Used Oil Burner (Yes = 'Y', No = 'N')	SI-10-C-3	SI670
16	USED_OIL_MARKET_BURNER	27	1	A	Used Oil Fuel Marketer Who Directs Shipment of Off-Specification Used Oil to Off-Specification Used Oil Burner (Yes = 'Y', No = 'N')	SI-10-C-4-A	SI680
17	USED_OIL_SPEC_MARKETER	28	1	A	Used Oil Fuel Marketer Who First Claims the Used Oil Meets the Specifications (Yes = 'Y', No = 'N')	SI-10-C-4-B	SI690
Total Record Length:			28				

FLAT FILE ID# - SI3

Source Form: Site ID **Description:** Handler Other Universal Waste Activities

This file captures the information contained in Section 10, Block B, Question 1E of the Site ID form. The relationship of these data records to the reported site is *n:1*, that is, there can be multiple other waste activities for each site.

Key Fields: Handler ID Number (HANDLER_ID); Other Universal Waste Activities (UNIVERSAL_WASTE). Each record in the SI3 file must contain a unique combination of the Handler ID Number and Other Universal Waste Activities.

Note: The SI3 file is NOT REQUIRED. The edits for this file apply only if you provide data for this file.

Field No.	Field Name	Starting Column	Field Length	Data Type	Description	Location on Form	Edit Number
1	HANDLER_ID	1	12	A	EPA Identification Number	SI-2	SI700
2	UNIVERSAL_WASTE	13	1	A	Other Universal Waste Activities	SI-10-B-1-E	SI720
3	GENERATED	14	1	A	Generated Other Universal Waste Activities (Yes = 'Y', No = 'N')	SI-10-B-1-E	SI730, SI750
4	ACCUMULATED	15	1	A	Accumulated Other Universal Waste Activities (Yes = 'Y', No = 'N')	SI-10-B-1-E	SI740, SI750
Total Record Length:			15				

FLAT FILE ID# - SI4

Source Form: Site ID **Description:** Waste Codes for Federally Regulated Hazardous Wastes

This file captures the information contained in Section 11, Block A of the Site ID form. The relationship of these data records to the reported site is *n*: 1, that is, there can be multiple federal waste codes for each site.

Key Fields: Handler ID Number (HANDLER_ID); Federal Waste Code (EPA_WASTE_CODE). Each record in the SI4 file must contain a unique combination of the Handler ID Number and Federal Waste Code.

Note: The SI4 file is NOT REQUIRED. The edits for this file apply only if you provide data for this file.

Field No.	Field Name	Starting Column	Field Length	Data Type	Description	Location on Form	Edit Number
1	HANDLER_ID	1	12	A	EPA Identification Number	SI-2	SI760
2	EPA_WASTE_CODE	13	4	A	Waste Codes for Federally Regulated Hazardous Wastes	SI-11-A	SI780
Total Record Length:			16				

FLAT FILE ID# - SI5

Source Form: Site ID **Description:** Waste Codes for State-Regulated Hazardous Wastes

This file captures the information contained in Section 11, Block B of the Site ID form. The relationship of these data records to the reported site is *n:1*, that is, there can be multiple state waste codes for each site.

Key Fields: Handler ID Number (HANDLER_ID); State Waste Code (STATE_WASTE_CODE). Each record in the SI5 file must contain a unique combination of the Handler ID Number and State Waste Code.

Note: The SI5 file is NOT REQUIRED. The edits for this file apply only if you provide data for this file.

Field No.	Field Name	Starting Column	Field Length	Data Type	Description	Location on Form	Edit Number
1	HANDLER_ID	1	12	A	EPA Identification Number	SI-2	SI790
2	STATE_WASTE_CODE	13	6	A	Waste Code for State-Regulated Hazardous Waste	SI-11-B	SI810
Total Record Length:			18				

FLAT FILE ID# - SI6

Source Form: Site ID **Description:** North American Industry Classification System Codes for the Site

This file captures the information contained in Section 6 of the Site ID form. The relationship of these data records to the reported site is *n:1*, that is, there can be multiple NAICS for each site.

Key Fields: Handler ID Number (HANDLER_ID); NAICS Sequence Number (NAICS_SEQ). Each record in the SI6 file must contain a unique combination of the Handler ID Number and the NAICS Sequence Number.

Note: The SI6 file is REQUIRED. At least one record with a sequence number of 1 must be provided for each handler.

Field No.	Field Name	Starting Column	Field Length	Data Type	Description	Location on Form	Edit Number
1	HANDLER_ID	1	12	A	EPA Identification Number	SI-2	SI200, SI230
2	NAICS_SEQ	13	4	I	NAICS Sequence Number	Assigned by Respondent	SI210, SI235
3	NAICS_CODE	17	6	A	North American Industry Classification System Code	SI-6	SI220
Total Record Length:			22				

FLAT FILE ID# - SI7

Source Form: Site ID **Description:** Site Identification Form Certification

This file captures the information contained in Section 13 of the Site ID form. The relationship of these data records to the reported site is *n:1*, that is, there can be multiple certifications for each site.

Key Fields: Handler ID Number (HANDLER_ID); Certification Sequence Number (CERT_SEQ). Each record in the SI7 file must contain a unique combination of the Handler ID Number and Certification Sequence Number.

Note: The SI7 file is REQUIRED. At least one record must be provided for each handler.

Field No.	Field Name	Starting Column	Field Length	Data Type	Description	Location on Form	Edit Number
1	HANDLER_ID	1	12	A	EPA Identification Number	SI-2	SI240, SI290
2	CERT_SEQ	13	2	I	Certification Sequence Number	Assigned by Respondent	SI250
3	CERT_FIRST_NAME	15	15	A	Certification First Name	SI-13	SI265
4	CERT_MIDDLE_INITIAL	30	1	A	Certification Middle Initial	SI-13	
5	CERT_LAST_NAME	31	15	A	Certification Last Name	SI-13	SI260
6	CERT_TITLE	46	15	A	Certification Title	SI-13	SI270
7	CERT_SIGNED_DATE	61	8	I	Date Certification was Signed (CCYYMMDD)	SI-13	SI280
Total Record Length:			68				

FLAT FILE ID# - SI8

Source Form: NA **Description:** State Specific Activities

This file reports the state specific activities for each site. Although not on the EPA Form 8700-13A/B, this file is available for states who wish to report this information. The relationship of these data records to the reported site is *n*:1, that is, there can be multiple state specific activities for each site.

Key Fields: Handler ID Number (HANDLER_ID); State Activity Type (STATE_ACTIVITY_TYPE). Each record in the SI8 file must contain a unique combination of the Handler ID Number and State Activity Type.

Note: The SI8 file is NOT REQUIRED. The edits for this file apply only if you provide data for this file.

Field No.	Field Name	Starting Column	Field Length	Data Type	Description	Location on Form	Edit Number
1	HANDLER_ID	1	12	A	EPA Identification Number		SI820
2	STATE_ACTIVITY_TYPE	13	5	A	State Activity Type		SI830
3	NOTES	18	240	A	Notes/Comments		
Total Record Length:			257				

FLAT FILE ID# - SI9

Source Form: Site ID **Description:** Owner/Operator Name and Address

This file reports the owner and operator name and address for each site. The owner/operator name, date and type are on the EPA Form 8700-13A/B. The file specification includes owner/operator address information for states who wish to report this information. The relationship of these data records to the reported site is n:1, that is, there can be multiple owner and operator names and addresses for each site.

Key Fields: Handler ID Number (HANDLER_ID); Owner/Operator Sequence Number (OWNER_OPERATOR_SEQ_NO) . Each record in the SI9 file must contain a unique combination of the Handler ID Number and Owner/Operator Sequence Number.

Note: The SI9 file is REQUIRED . At least two records must be provided for each handler - one record for current owner and one record for current operator.

Field No.	Field Name	Starting Column	Field Length	Data Type	Description	Location on Form	Edit Number
1	HANDLER_ID	1	12	A	EPA Identification Number		SI840
2	OWNER_OPERATOR_SEQ_NO	13	4	I	Owner/Operator Sequence Number		
3	OWNER_OPERATOR_INDICATOR	17	2	A	Owner/Operator Indicator (Current Owner = 'CO', Current Operator = 'CP')		SI910, SI920
4	OWNER_OPERATOR_NAME	19	40	A	Site's Legal Owner/Operator	SI-9-A, SI-9-B	SI440
5	OWNER_OPERATOR_DATE	59	8	I	Date Became Owner/Operator (CCYYMMDD)	SI-9-A, SI-9-B	SI420
6	OWNER_OPERATOR_TYPE	67	1	A	Owner/Operator Type (Private = 'P', County = 'C', District = 'D', Federal = 'F', Indian = 'I', Municipal = 'M', State = 'S', Other = 'O')	SI-9-A, SI-9-B	SI430
7	OWNER_OPERATOR_STREET_NO	68	12	A	Owner/Operator Street Number	SI-9-A	
8	OWNER_OPERATOR_STREET1	80	30	A	Owner/Operator Street 1	SI-9-A	
9	OWNER_OPERATOR_STREET2	110	30	A	Owner/Operator Street 2	SI-9-A	
10	OWNER_OPERATOR_CITY	140	25	A	Owner/Operator City	SI-9-A	
11	OWNER_OPERATOR_STATE	165	2	A	Owner/Operator State	SI-9-A	SI850

FLAT FILE ID# - SI9

Source Form: Site ID **Description:** Owner/Operator Name and Address

This file reports the owner and operator name and address for each site. The owner/operator name, date and type are on the EPA Form 8700-13A/B. The file specification includes owner/operator address information for states who wish to report this information. The relationship of these data records to the reported site is n:1, that is, there can be multiple owner and operator names and addresses for each site.

Key Fields: Handler ID Number (HANDLER_ID); Owner/Operator Sequence Number (OWNER_OPERATOR_SEQ_NO) . Each record in the SI9 file must contain a unique combination of the Handler ID Number and Owner/Operator Sequence Number.

Note: The SI9 file is REQUIRED . At least two records must be provided for each handler - one record for current owner and one record for current operator.

Field No.	Field Name	Starting Column	Field Length	Data Type	Description	Location on Form	Edit Number
12	OWNER_OPERATOR_ZIP	167	14	A	Owner/Operator Zip Code	SI-9-A	SI870
13	OWNER_OPERATOR_COUNTRY	181	50	A	Owner/Operator Country	SI-9-A	SI890
14	OWNER_OPERATOR_NOTES	231	240	A	Owner/Operator Notes		
Total Record Length:			470				

FLAT FILE ID# - GM1

Source Form: GM **Description:** Waste Measurement Information

This file captures data elements that have a 1:1 relationship to the reported waste. These data elements are as follows: GM Section 1, Block A and Blocks D through G.

Key Fields: Handler ID Number (HANDLER_ID); Page Number (HZ_PG). Each record in the GM1 file must contain a unique combination of the Handler ID Number and Page Number.

Note: The GM1 File is REQUIRED for handlers that generated RCRA hazardous waste that, in 2003, was accumulated on-site; managed on-site in a treatment, storage, or disposal unit; and / or shipped off-site for management.

Field No.	Field Name	Starting Column	Field Length	Data Type	Description	Location on Form	Edit Number
1	HANDLER_ID	1	12	A	EPA ID Number	Site ID Block	GM000
2	HZ_PG	13	5	I	Page Number	Assigned By Respondent	GM010
3	FORM_CODE	18	4	A	Waste Form Code	GM-1-E	GM220
4	UNIT_OF_MEASURE	22	1	A	Unit of Measure (Pounds = '1', Short Tons = '2', Kilograms = '3', Metric Tonnes = '4', Gallons = '5', Liters = '6', Cubic Yards = '7')	GM-1-G	GM020
5	WST_DENSITY	23	6	D3.2	Density	GM-1-G	GM030, GM040
6	DENSITY_UNIT_OF_MEASURE	29	1	A	Density Unit of Measure (lbs/gal = '1', sg = '2')	GM-1-G	GM030
7	ORIGIN_MANAGEMENT_METHOD	30	4	A	Origin management method for source code G25	GM-1-D	GM230
	OBSOLETE FIELD	34	1	A	Obsolete Field - must leave blank (formerly RCRA-Radioactive Mix)		
8	SOURCE_CODE	35	3	A	Source Code	GM-1-D	GM270
9	GEN_QTY	38	18	D11.6	Quantity Generated in Reporting Year	GM-1-F	GM050

FLAT FILE ID# - GM1

Source Form: GM **Description:** Waste Measurement Information

This file captures data elements that have a 1:1 relationship to the reported waste. These data elements are as follows: GM Section 1, Block A and Blocks D through G.

Key Fields: Handler ID Number (HANDLER_ID); Page Number (HZ_PG). Each record in the GM1 file must contain a unique combination of the Handler ID Number and Page Number.

Note: The GM1 File is REQUIRED for handlers that generated RCRA hazardous waste that, in 2003, was accumulated on-site; managed on-site in a treatment, storage, or disposal unit; and / or shipped off-site for management.

Field No.	Field Name	Starting Column	Field Length	Data Type	Description	Location on Form	Edit Number
10	INCLUDE_IN_NATIONAL_REPORT	56	1	A	Include Information in the National Hazardous Waste Report (Yes = 'Y', No = 'N')		GM310
11	DESCRIPTION	57	240	A	Waste Stream Description	GM-1-A	
12	NOTES	297	240	A	Comments/Notes	Bottom of GM Form	
13	ON_SITE_MANAGEMENT	537	1	A	Was this Waste Stream Managed On-Site (Yes = 'Y', No = 'N')	GM-2	GM320, GM330, GM335
14	OFF_SITE_SHIPMENT	538	1	A	Was this Waste Stream Shipped Off-Site (Yes = 'Y', No = 'N')	GM-3-A	GM340, GM350, GM355
Total Record Length:			538				

FLAT FILE ID# - GM2

Source Form: GM **Description:** EPA Hazardous Waste Codes for each GM page

This file captures the information contained in Section 1, Block B of the GM form. The relationship of these data records to the reported waste is *n:1*, that is, there can be multiple EPA waste codes for each unique reported waste.

Key Fields: Handler ID Number (HANDLER_ID); Page Number (HZ_PG); EPA Hazardous Waste Code (EPA_WASTE_CODE). Each record in the GM2 file must contain a unique combination of the Handler ID Number, Page Number, and EPA Hazardous Waste Code.

Note: For each waste stream, either EPA Hazardous Waste Code information (GM2) is REQUIRED or State Hazardous Waste Code information (GM3) is REQUIRED.

Field No.	Field Name	Starting Column	Field Length	Data Type	Description	Location on Form	Edit Number
1	HANDLER_ID	1	12	A	EPA ID Number	Site ID Block	GM060, GM100
2	HZ_PG	13	5	I	Page Number	Assigned by Respondent	
3	EPA_WASTE_CODE	18	4	A	EPA Hazardous Waste Code	GM-1-B	GM090
Total Record Length:			21				

FLAT FILE ID# - GM3

Source Form: GM **Description:** State Hazardous Waste Codes for each GM page

This file captures the information contained in Section 1, Block C of the GM form. The relationship of these data records to the reported waste is *n:1*, that is, there can be multiple State waste codes for each unique reported waste.

Key Fields: Handler ID Number (HANDLER_ID); Page Number (HZ_PG); State Hazardous Waste Code (WASTE_CODE). Each record in the GM3 file must contain a unique combination of the Handler ID Number, Page Number, and State Hazardous Waste Code.

Note: For each waste stream, either EPA Hazardous Waste Code information (GM2) is REQUIRED or State Hazardous Waste Code information (GM3) is REQUIRED.

Field No.	Field Name	Starting Column	Field Length	Data Type	Description	Location on Form	Edit Number
1	HANDLER_ID	1	12	A	EPA ID Number	Site ID Block	GM280
2	HZ_PG	13	5	I	Page Number	Assigned by respondent	
3	WASTE_CODE	18	6	A	State Hazardous Waste Code	GM-1-C	GM300
Total Record Length:			23				

FLAT FILE ID# - GM4

Source Form: GM **Description:** Off-Site Management Information for the Reported Waste on Each GM Page

This file captures off-site treatment information for the reported waste as represented in GM Section 3, Blocks B through D. The relationship of these data records to the reported waste is *n:1*, that is, there can be multiple off-site information for each unique reported waste.

Key Fields: Handler ID Number (HANDLER_ID); Page Number (HZ_PG); Off-site Sequence Number (IO_PG_NUM_SEQ). Each record in the GM4 file must contain a unique combination of the Handler ID Number, Page Number, and Off-site Sequence Number.

Note: The GM4 File is REQUIRED for handlers that generated RCRA hazardous waste that, in 2003, was shipped off-site for management.

Field No.	Field Name	Starting Column	Field Length	Data Type	Description	Location on Form	Edit Number
1	HANDLER_ID	1	12	A	EPA ID Number	Site ID Block	GM110
2	HZ_PG	13	5	I	Page Number	Assigned by Respondent	
3	IO_PG_NUM_SEQ	18	5	I	Off-site Sequence Number	GM-3 Site# Block	GM120
4	MANAGEMENT_METHOD	23	4	A	Off-site Management Method	GM-3-C	GM160
5	IO_TDR_ID	27	12	A	EPA ID No. of Off-site Facility Shipped to	GM-3-B	GM140
6	IO_TDR_QTY	39	18	D11.6	Total Quantity Shipped to EPA ID in Field 5 in Current Reporting Year	GM-3-D	GM150
Total Record Length:			56				

FLAT FILE ID# - GM5

Source Form: GM **Description:** On-site Management Information for the Reported Waste on Each GM Page.

This file captures on-site treatment information as contained in Section 2 of the GM form. The relationship of the data element to the reported waste is *n:1*, that is, there can be multiple on-site information for each unique reported waste.

Key Fields: Handler ID Number (HANDLER_ID); Page Number (HZ_PG); On-site Sequence Number (SYS_PG_NUM_SEQ). Each record in the GM5 file must contain a unique combination of the Handler ID Number, Page Number, and On-site Sequence Number.

Note: The GM5 File is REQUIRED for handlers that generated RCRA hazardous waste that, in 2003, was accumulated on-site or managed on-site in a treatment, storage, or disposal unit.

Field No.	Field Name	Starting Column	Field Length	Data Type	Description	Location on Form	Edit Number
1	HANDLER_ID	1	12	A	EPA ID Number	Site ID Block	GM170
2	HZ_PG	13	5	I	Page Number	Assigned by Respondent	
3	SYS_PG_NUM_SEQ	18	5	I	On-site Sequence Number	GM-2 System# Block	GM180
4	MANAGEMENT_METHOD	23	4	A	On-site Management Method	GM-2	GM210
5	SYS_TDR_QTY	27	18	D11.6	Quantity Treated, Disposed, or Recycled On-site in Current Reporting Year	GM-2	GM190
Total Record Length:			44				

FLAT FILE ID# - WR1

Source Form: WR **Description:** Received Waste Description and Measurement Information

This file captures the information contained in Block A and Blocks D through H of the WR form. The relationship of these data records to the reported site is *n:1*, that is, there can be multiple received waste for each site.

Key Fields: Handler ID Number (HANDLER_ID); Page Number (HZ_PG); Waste Number (SUB_PG_NUM). Each record in the WR1 file must contain a unique combination of Handler ID Number, Page Number, and Waste Number.

Note: The WR1 is REQUIRED for handlers who, during 2003, received RCRA hazardous waste from off-site.

Field No.	Field Name	Starting Column	Field Length	Data Type	Description	Location on Form	Edit Number
1	HANDLER_ID	1	12	A	EPA ID Number	Site ID Block	WR000
2	HZ_PG	13	5	I	Page Number	Assigned by Respondent	WR010
3	SUB_PG_NUM	18	1	I	Waste Number	Printed on Form	WR020
4	FORM_CODE	19	4	A	Form Code	WR-G	WR180
5	UNIT_OF_MEASURE	23	1	A	Unit of Measure (Pounds = '1', Short Tons = '2', Kilograms = '3', Metric Tonnes = '4', Gallons = '5', Liters = '6', Cubic Yards = '7')	WR-F	WR030
6	WST_DENSITY	24	6	D3.2	Density	WR-F	WR040, WR050
7	DENSITY_UNIT_OF_MEASURE	30	1	A	Density Unit of Measure (lbs/gal = '1', sg = '2')	WR-F	WR040
	OBSOLETE FIELD	31	1	A	Obsolete Field - must leave blank (formerly RCRA-Radioactive Mix)		
8	MANAGEMENT_METHOD	32	4	A	Management Method	WR-H	WR060
9	IO_TDR_ID	36	12	A	Off-site Source EPA ID Number	WR-D	WR070

FLAT FILE ID# - WR1

Source Form: WR **Description:** Received Waste Description and Measurement Information

This file captures the information contained in Block A and Blocks D through H of the WR form. The relationship of these data records to the reported site is *n:1*, that is, there can be multiple received waste for each site.

Key Fields: Handler ID Number (HANDLER_ID); Page Number (HZ_PG); Waste Number (SUB_PG_NUM). Each record in the WR1 file must contain a unique combination of Handler ID Number, Page Number, and Waste Number.

Note: The WR1 is REQUIRED for handlers who, during 2003, received RCRA hazardous waste from off-site.

Field No.	Field Name	Starting Column	Field Length	Data Type	Description	Location on Form	Edit Number
10	IO_TDR_QTY	48	18	D11.6	Quantity Received in Current Reporting Year	WR-E	WR080
11	INCLUDE_IN_NATIONAL_REPORT	66	1	A	Include Information in the National Hazardous Waste Report (Yes = 'Y', No = 'N')		WR230
12	DESCRIPTION	67	240	A	Waste Stream Description	WR-A	
13	NOTES	307	240	A	Comments/Notes	Bottom of WR Form	
Total Record Length:			546				

FLAT FILE ID# - WR2

Source Form: WR **Description:** EPA Hazardous Waste Codes for Each Reported Waste Received

This file contains the EPA hazardous waste codes for each WR form page as described in Form WR, Block B. The relationship of these data records to the reported waste is *n:1*, that is, there can be multiple EPA waste codes for each unique reported waste.

Key Fields: Handler ID Number (HANDLER_ID); Page Number (HZ_PG); Waste Number (SUB_PG_NUM); EPA Hazardous Waste Code (EPA_WASTE_CODE). Each record in the WR2 file must contain a unique combination of the Handler ID Number, Page Number, Waste Number, and EPA Hazardous Waste Code.

Note: For each waste stream, either EPA Hazardous Waste Code information (WR2) is REQUIRED or State Hazardous Waste Code information (WR3) is REQUIRED.

Field No.	Field Name	Starting Column	Field Length	Data Type	Description	Location on Form	Edit Number
1	HANDLER_ID	1	12	A	EPA ID Number	Site ID Block	WR090, WR130
2	HZ_PG	13	5	I	Page Number	Assigned by Respondent	
3	SUB_PG_NUM	18	1	I	Waste Number	Printed on Form	WR020
4	EPA_WASTE_CODE	19	4	A	EPA Hazardous Waste Code	WR-B	WR110
Total Record Length:			22				

FLAT FILE ID# - WR3

Source Form: WR **Description:** State Hazardous Waste Codes for Each Reported Waste Received

This file contains the State hazardous waste codes for each WR form page as described in Form WR, Block C. The relationship of these data records to the reported waste is n:1, that is, there can be multiple State waste codes for each unique reported waste.

Key Fields: Handler ID Number (HANDLER_ID); Page Number (HZ_PG); Waste Number (SUB_PG_NUM); State Hazardous Waste Code (WASTE_CODE). Each record in the WR3 file must contain a unique combination of the Handler ID Number, Page Number, Waste Number, and State Hazardous Waste Code.

Note: For each waste stream, either EPA Hazardous Waste Code information (GM2) is REQUIRED or State Hazardous Waste Code information (GM3) is REQUIRED.

Field No.	Field Name	Starting Column	Field Length	Data Type	Description	Location on Form	Edit Number
1	HANDLER_ID	1	12	A	EPA ID Number	Site ID Block	WR200
2	HZ_PG	13	5	I	Page Number	Assigned by Respondent	
3	SUB_PG_NUM	18	1	I	Waste Number	Printed on Form	WR020
4	WASTE_CODE	19	6	A	State Hazardous Waste Code	WR-C	WR220
Total Record Length:			24				

FLAT FILE ID# - OI1

Source Form: OI **Description:** Identification of All Handlers to Whom or From Whom Waste was Shipped, and Transporters

This file captures information from the OI form. *This flat file should never be included in submissions to RCRAInfo.*

Key Fields: Handler ID Number (HANDLER_ID); Page Number (OSITE_PGNUM). Each record in the OI1 file must contain a unique combination of EPA ID Number and Page Number.

Field No.	Field Name	Starting Column	Field Length	Data Type	Description	Location on Form	Edit Number
1	HANDLER_ID	1	12	A	EPA ID Number	Site ID Block	
2	OSITE_PGNUM	13	5	I	Page Number	Assigned by Respondent	
3	OFF_ID	18	12	A	Off-site Installation or Transporter EPA ID Number	OI-A	
4	WST_GEN_FLG	30	1	A	Handler Type = Generator (Checked = 'Y', Unchecked and not implementer required = 'U', Unchecked and implementer required = 'N')	OI-C	
5	WST_TRNS_FLG	31	1	A	Handler Type= Transporter (Checked = 'Y', Unchecked and not implementer required = 'U', Unchecked and implementer required = 'N')	OI-C	
6	WST_TSDR_FLG	32	1	A	Handler Type = TSDR (Checked = 'Y', Unchecked and not implementer required = 'U', Unchecked and implementer required = 'N')	OI-C	
7	ONAME	33	40	A	Name of Off-site Installation or Transporter	OI-B	
8	O1STREET	73	30	A	1st Street Address Line of Installation or Transporter	OI-D	
9	O2STREET	103	30	A	2nd Street Address Line of Installation or Transporter	OI-D	
10	OCITY	133	25	A	City	OI-D	

FLAT FILE ID# - OI1

Source Form: OI **Description:** Identification of All Handlers to Whom or From Whom Waste was Shipped, and Transporters

This file captures information from the OI form. *This flat file should never be included in submissions to RCRAInfo.*

Key Fields: Handler ID Number (HANDLER_ID); Page Number (OSITE_PGNUM). Each record in the OI1 file must contain a unique combination of EPA ID Number and Page Number.

Field No.	Field Name	Starting Column	Field Length	Data Type	Description	Location on Form	Edit Number
11	OSTATE	158	2	A	State	OI-D	
12	OZIP	160	9	A	Zip Code	OI-D	
13	NOTES	169	240	A	Comments/Notes	Bottom of OI Form	
Total Record Length:			408				

APPENDIX C

Data Assessment Edits

APPENDIX C - Data Assessment Edits

All data submitted must meet the appropriate data assessment edits. The data assessment edits for non-required data elements apply only if the data is provided. For child table records, data assessment edits apply only if the record is being submitted.

C.1 Generic Data Edits

Edit Number	Form Location	Edit Description	Select Logic
GN000	All	A non-valid character was found in a character field.	CHARACTER = allowed value as specified in Section 4.3.1
GN010	All	Alphabetic character found in numeric field.	NUMERIC_DIGIT = allowed value as specified in Section 4.3.2 or Section 4.3.3
GN020	All	Duplicate records found in file submission.	Combination of key fields for specific file must be unique

C.2 Control File Edits

Edit Number	Form Location	Edit Description	Select Logic
CL000	Control File	The first two characters of the file name must be a valid state postal code (see Appendix F).	SUBSTR(FILE_NAME,1,2) = valid state postal code (see Appendix F).
CL010	Control File	Flat files specified must be for the state for which data is being submitted.	SUBSTR(FILE_NAME,1,2) = state postal code of submission
CL020	Control File	Characters 3-5 of the file name must be a valid flat file identifier (SI1, SI2, SI3, SI4, SI5, SI6, SI7, SI8, SI9, GM1, GM2, GM3, GM4, GM5, WR1, WR2, WR3).	SUBSTR(FILE_NAME,3,3) = SI1 or SI2 or SI3 or SI4 or SI5 or SI6 or SI7 or SI8 or SI9 or GM1 or GM2 or GM3 or GM4 or GM5 or WR1 or WR2 or WR3
CL030	Control File	Characters 6-8 must be greater than zero and less than or equal to 366.	SUBSTR(FILE_NAME,6,3) > 0 AND <= 366
CL040	Control File	The date created must be a valid date greater than 19000101 (January 1, 1900).	DATE_CREATED = valid date
CL050	Control File	The record count must be greater than zero and less than or equal to 99,999,999.	RECORD_COUNT > 0 AND <= 99999999
CL060	Control File	The report cycle must be '2003'.	REPORT_CYCLE = '2003'

C.3 Site Identification Form Edits

Edit Number	Form Location	Edit Description	Select Logic
SI000	SI-2	The first two characters of the EPA ID must match the state code for which data is being submitted.	SUBSTR(HANDLER_ID,1,2) = state postal code of submission
SI005	SI-1 / SI-2	If the reason for submittal is for the Hazardous Waste Report, the EPA ID must already exist in RCRAInfo.	IF SUBMITTAL_REASON = 'R' THEN HANDLER_ID in HBASIC
SI015	SI-1	The reason for submittal must be 'R' or 'B'.	SUBMITTAL_REASON = 'R' or 'B'
SI020	SI-3	Handler name must be provided.	HANDLER_NAME <> ''
SI040	SI-4	Location street must be provided.	LOCATION_STREET_1 <> ''
SI050	SI-4	Location city, town, or village must be provided.	LOCATION_CITY <> ''
SI060	SI-4	Location county name must be a valid value.	COUNTY_NAME = county name provided in LU_COUNTY
SI070	SI-4	Location state must be a valid postal state (see Appendix F)	LOCATION_STATE = value specified in Appendix F.
SI080	SI-4	Location zip code must be provided.	LOCATION_ZIP <> ''
SI085	SI-7	Location zip code must contain only the characters 0, 1, 2, 3, 4, 5, 6, 7, 8, 9, or blank.	LOCATION_ZIP characters = '0', '1', '2', '3', '4', '5', '6', '7', '8', '9', ''
SI090	SI-4	The state indicated in the site location address must be the same as the first two characters of the site's EPA ID.	LOCATION_STATE = SUBSTR(HANDLER_ID,1,2)
SI100	SI-7	Mailing street must be provided.	MAIL_STREET1 <> ''
SI110	SI-7	Mailing city, town, or village must be provided.	MAIL_CITY <> ''
SI120	SI-7	If the mailing address is in the United States then the mailing state must be a valid postal state (see Appendix F).	IF MAIL_COUNTRY = ' ' OR MAIL_COUNTRY = 'UNITED STATES' Then MAIL_STATE = value specified in Appendix F.
SI130	SI-7	Mailing zip code must be provided.	MAIL_ZIP <> ''
SI135	SI-7	Mailing zip code must contain only the characters 0, 1, 2, 3, 4, 5, 6, 7, 8, 9, or blank.	MAIL_ZIP characters = '0', '1', '2', '3', '4', '5', '6', '7', '8', '9', ''

Edit Number	Form Location	Edit Description	Select Logic
SI140	SI-7	Mailing country name must be a valid value. If the mailing country is blank, a value of UNITED STATES will be assumed.	MAIL_COUNTRY = country name provided in LU_COUNTRY
SI150	SI-8	Contact last name must be provided.	CONTACT_LAST_NAME <> ''
SI160	SI-8	Contact first name must be provided.	CONTACT_FIRST_NAME <> ''
SI170	SI-9	Contact phone number must be provided.	CONTACT_PHONE <> ''
SI175	SI-10-A-1	State generator status must be registered with the RCRAInfo database.	STATE_GENERATOR_STATUS = implementer defined value in LU_GENERATOR_STATUS2
SI180	SI-10-A-1	Generator of hazardous waste indicator must equal '1', '2', '3', or 'N'.	GENERATOR_ACTIVITY = '1' or '2' or '3' or 'N'
SI190	SI-10-A-3	Treater, Storer, or Disposer indicator must equal 'Y' or 'N'.	TSD_ACTIVITY = 'Y' or 'N'
SI200	SI-2	SI6 record is present, but corresponding record does not exist in the SI1 file.	HANDLER_ID in SI1 file
SI210	SI- Assigned by respondent	NAICS sequence number must be greater than zero.	NAICS_SEQ > 0
SI220	SI-6	North American industry classification system code must be a valid value.	NAICS_CODE = NAICS code provided in LU_NAICS
SI230	SI-6	NAICS data must be provided.	HANDLER_ID in SI1 file and in SI6 file
SI235	SI-6	One SI6 record with sequence number = 1 must be provided.	Record in SI6 where NAICS_SEQ = 1
SI240	SI-2	SI7 record is present, but corresponding record does not exist in the SI1 file.	HANDLER_ID in SI1file
SI250	SI- Assigned by respondent	Certification sequence number must be greater than zero.	CERT_SEQ > 0
SI260	SI-13	Certification last name must be provided.	CERT_LAST_NAME <> ''
SI265	SI-13	Certification first name must be provided.	CERT_FIRST_NAME <> ''

Edit Number	Form Location	Edit Description	Select Logic
SI270	SI-13	Certification title must be provided.	CERT_TITLE <> ''
SI280	SI-13	Date certification was signed must be a valid date greater than 20030101 (January 1, 2003) and less than today.	CERT_SIGNED_DATE >= '20030101' AND CERT_SIGNED_DATE < TODAY
SI290	SI-13	Certification data must be provided.	HANDLER_ID in SI1 file and in SI7 file
SI310	SI-5	Site land type must equal 'P', 'C', 'D', 'F', 'I', 'M', 'S', or 'O'.	LAND_TYPE = 'P' or 'C' or 'D' or 'F' or 'I' or 'M' or 'S' or 'O'
SI420	SI-9-A, SI-9-B	Owner / operator date must be a valid date greater than 1700101 (January 1, 1700).	OWNER_OPERATOR_DATE = valid date
SI430	SI-9-A, SI-9-B	Owner / operator type must equal 'P', 'C', 'D', 'F', 'I', 'M', 'S', or 'O'.	OWNER_OPERATOR_TYPE = 'P' or 'C' or 'D' or 'F' or 'I' or 'M' or 'S' or 'O'
SI440	SI-9-A, SI-9-B	Owner / operator name must be provided.	OWNER_OPERATOR_NAME <> ''.
SI460	SI-10-A-1	Importer of hazardous waste indicator must equal 'Y' or 'N'.	IMPORTER_ACTIVITY = 'Y' or 'N'
SI470	SI-10-A-1	Mixed waste generator indicator must equal 'Y' or 'N'.	MIXED_WASTE_GENERATOR = 'Y' or 'N'
SI480	SI-10-A-2	Transporter indicator must equal 'Y' or 'N'.	TRANSPORTER_ACTIVITY = 'Y' or 'N'
SI490	SI-10-A-4	Recycler indicator must equal 'Y' or 'N'.	RECYCLER_ACTIVITY = 'Y' or 'N'
SI500	SI-10-A-5	Small quantity on-site burner exemption indicator must equal 'Y' or 'N'.	HWFUEL_ONSITE_BURNER_EXEMPT = 'Y' or 'N'
SI510	SI-10-A-5	Smelting, melting, refining furnace exemption indicator must equal 'Y' or 'N'.	HWFUEL_FURNACE_EXEMPT = 'Y' or 'N'
SI520	SI-10-A-6	Underground injection control indicator must equal 'Y' or 'N'.	UNDERGROUND_INJECTION_ACTIVITY = 'Y' or 'N'
SI530	SI-2	SI2 record is present, but corresponding record does not exist in the SI1 file.	HANDLER_ID not in SI1 file
SI540	SI-10-B-1-A	Large quantity generator of batteries indicator must equal 'Y' or 'N'.	GEN_BATTERIES = 'Y' or 'N'
SI550	SI-10-B-1-A	Large quantity accumulator of batteries indicator must equal 'Y' or 'N'.	ACC_BATTERIES = 'Y' or 'N'

Edit Number	Form Location	Edit Description	Select Logic
SI560	SI-10-B-1-B	Large quantity generator of pesticides indicator must equal 'Y' or 'N'.	GEN_PESTICIDES = 'Y' or 'N'
SI570	SI-10-B-1-B	Large quantity accumulator of pesticides indicator must equal 'Y' or 'N'.	ACC_PESTICIDES = 'Y' or 'N'
SI580	SI-10-B-1-C	Large quantity generator of thermostats indicator must equal 'Y' or 'N'.	GEN_THERMOSTATS = 'Y' or 'N'
SI590	SI-10-B-1-C	Large quantity accumulator of thermostats indicator must equal 'Y' or 'N'.	ACC_THERMOSTATS = 'Y' or 'N'
SI600	SI-10-B-1-D	Large quantity generator of lamps indicator must equal 'Y' or 'N'.	GEN_LAMPS = 'Y' or 'N'
SI610	SI-10-B-1-D	Large quantity accumulator of lamps indicator must equal 'Y' or 'N'.	ACC_LAMPS = 'Y' or 'N'
SI620	SI-10-B-2	Destination facility for universal waste indicator must equal 'Y' or 'N'.	UNIVERSAL_WASTE_DEST_FACILITY = 'Y' or 'N'
SI630	SI-10-C-1-A	Used oil transporter indicator must equal 'Y' or 'N'.	USED_OIL_TRANSPORTER = 'Y' or 'N'
SI640	SI-10-C-1-B	Used oil transfer facility indicator must equal 'Y' or 'N'.	USED_OIL_TRANSFER_FACILITY = 'Y' or 'N'
SI650	SI-10-C-2-A	Used oil processor indicator must equal 'Y' or 'N'.	USED_OIL_PROCESSOR = 'Y' or 'N'
SI660	SI-10-C-2-B	Used oil re-refiner indicator must equal 'Y' or 'N'.	USED_OIL_REFINER = 'Y' or 'N'
SI670	SI-10-C-3	Off-specification used oil burner indicator must equal 'Y' or 'N'.	USED_OIL_BURNER = 'Y' or 'N'
SI680	SI-10-C-4-A	Used oil fuel marketer who directs shipment of off-specification used oil to off-specification used oil burner indicator must equal 'Y' or 'N'.	USED_OIL_MARKET_BURNER = 'Y' or 'N'
SI690	SI-10-C-4-B	Used oil fuel marketer who first claims the used oil meets the specification indicator must equal 'Y' or 'N'.	USED_OIL_SPEC_MARKETER = 'Y' or 'N'
SI700	SI-2	SI3 record is present, but corresponding record does not exist in the SI1 file.	HANDLER_ID in SI1 file

Edit Number	Form Location	Edit Description	Select Logic
SI720	SI-10-B-1-E	Other universal waste activities must be an implementer defined value other than 'B', 'P', 'T', or 'L'.	UNIVERSAL_WASTE = implementer defined value in LU_UNIVERSAL_WASTE.
SI730	SI-10-B-1-E	Generated other universal waste activities indicator must equal 'Y' or 'N'.	GENERATED = 'Y' or 'N'
SI740	SI-10-B-1-E	Accumulated other universal waste activities indicator must equal 'Y' or 'N'.	ACCUMULATED = 'Y' or 'N'
SI750	SI-10-B-1-E	Other universal waste activities must indicate whether the activity was generated or accumulated.	If GENERATED = 'N' Then ACCUMULATED = 'Y' If ACCUMULATED = 'N' Then GENERATED = 'Y'
SI760	SI-2	SI4 record is present, but corresponding record does not exist in the SI1 file.	HANDLER_ID in SI1 file
SI780	SI-11-A	Waste code for federally regulated hazardous wastes must be a federal waste code value specified in the <i>2003 Hazardous Waste Report, Instructions and Forms</i> .	EPA_WASTE_CODE = value specified in the <i>2003 Hazardous Waste Report, Instructions and Forms</i>
SI790	SI-2	SI5 record is present, but corresponding record does not exist in the SI1 file.	HANDLER_ID in SI1 file
SI810	SI-11-B	Waste code must be registered with the RCRAInfo database.	STATE_WASTE_CODE = implementer defined value in LU_WASTE_CODE
SI820		SI8 record is present, but corresponding record does not exist in the SI1 file.	HANDLER_ID in SI1 file
SI830		State activity type must be registered with the RCRAInfo database.	STATE_ACTIVITY_TYPE = implementer defined value in LU_STATE_ACTIVITY
SI840		SI9 record is present, but corresponding record does not exist in the SI1 file.	HANDLER_ID in SI1 file
SI850		Owner/operator state must be a value specified in Appendix F or blank.	OWNER_OPERATOR_STATE = value specified in Appendix F or ''
SI870		Owner/operator zip code must contain only the characters 0, 1, 2, 3, 4, 5, 6, 7, 8, 9, or blank.	OWNER_OPERATOR_ZIP characters = '0', '1', '2', '3', '4', '5', '6', '7', '8', '9', ''

Edit Number	Form Location	Edit Description	Select Logic
SI890		Owner/operator country must be a valid value. If the owner/operator country is blank, a value of UNITED STATES will be assumed.	OWNER_OPERATOR_COUNTRY = country name provided in LU_COUNTRY
SI910		Owner / operator indicator must equal 'CO' or 'CP'.	OWNER_OPERATOR_INDICATOR = 'CO' or 'CP'
SI920		At least one SI9 record with owner/operator indicator = 'CO' and at least one SI9 record with owner/operator indicator = 'CP' must be provided.	There must be at least one record in SI9 where OWNER_OPERATOR_INDICATOR = 'CO' and there must be a least one record in SI9 where OWNER_OPERATOR_INDICATOR = 'CP'
SI999		Include in national report flag must equal 'Y' or 'N'.	INCLUDE_IN_NATIONAL_REPORT = 'Y' or 'N'

C.4 Form GM Edits

Edit Number	Form Location	Edit Description	Select Logic
GM000	GM	GM1 record is present, but corresponding record does not exist in the SI1 file.	HANDLER_ID in SI1file
GM010	GM	Page number must be greater than zero.	HZ_PG > 0
GM020	GM-1-H	Generated quantity unit of measure must equal '1', '2', '3', '4', '5', '6', or '7'.	UNIT_OF_MEASURE = '1' or '2' or '3' or '4' or '5' or '6' or '7'
GM030	GM-1-H	If the generated quantity unit of measure is '5', '6' or '7' then density must be greater than zero and density unit of measure must be 1 or 2.	If UNIT_OF_MEASURE = '5', '6', or '7' Then WST_DENSITY > 0 AND DENSITY_UNIT_OF_MEASURE = 1 or 2
GM040	GM-1-H	Waste density must be greater than or equal to 0.01 and less than or equal to 999.99, or equal to 0.	WST_DENSITY >= 0.01 and <= 999.99 or WST_DENSITY = 0
GM050	GM-1-G	Quantity generated in the reporting year must be greater than or equal to 0.000001 and less than or equal to 99,999,999,998.999999, or equal to zero.	GEN_QTY >= 0.000001 and <= 99999999998.999999 or GEN_QTY = 0
GM060	GM	GM2 record is present, but corresponding record does not exist in the GM1 file.	HANDLER_ID and HZ_PG in GM1 file
GM090	GM-1-B	EPA hazardous waste code must be an EPA waste code value specified in the <i>2003 Hazardous Waste Report, Instructions and Forms</i> .	EPA_WASTE_CODE = value specified in the <i>2003 Hazardous Waste Report, Instructions and Forms</i>
GM100	GM-1-B	EPA or State hazardous waste data must be provided.	HANDLER_ID and HZ_PG in GM1 file and in GM2 or GM3 file
GM110	GM	GM4 record is present, but corresponding record does not exist in the GM1 file.	HANDLER_ID and HZ_PG in GM1 file
GM120	GM - Assigned by respondent	Off-site code sequence number must be greater than zero.	IO_PG_NUM_SEQ > 0
GM140	GM-3-B	The off-site shipment handler EPA ID number must begin with a valid state postal code.	SUBSTR(IO_TDR_ID,1,2) = valid state postal code (see Appendix F)

Edit Number	Form Location	Edit Description	Select Logic
GM150	GM-3-D	Total quantity shipped off-site in the reporting year must be greater than or equal to 0.000001 and less than or equal to 99,999,999,998.999999.	IO_TDR_QTY >= 0.000001 and <= 99999999998.999999
GM160	GM-3-C	The off-site management method must be a management method specified in the <i>2003 Hazardous Waste Report, Instructions and Forms</i> or blank.	MANAGEMENT_METHOD = management method specified in the <i>2003 Hazardous Waste Report, Instructions and Forms</i> or blank.
GM170	GM	GM5 record is present, but corresponding record does not exist in the GM1 file.	HANDLER_ID and HZ_PG in GM1 file
GM180	GM - Assigned by respondent	On-site sequence number must be greater than zero.	SYS_PG_NUM_SEQ > 0
GM190	GM-2	Total quantity treated, disposed, or recycled on-site in the reporting year must be greater than or equal to 0.000001 and less than or equal to 99,999,999,998.999999.	SYS_TDR_QTY >= 0.000001 and <= 99999999998.999999
GM210	GM-2	The on-site management method must contain a management method specified in the <i>2003 Hazardous Waste Report, Instructions and Forms</i> .	MANAGEMENT_METHOD = value specified in the <i>2003 Hazardous Waste Report, Instructions and Forms</i>
GM220	GM-1-E	The form code must be a form code value specified in the <i>2003 Hazardous Waste Report, Instructions and Forms</i> or blank.	FORM_CODE = value specified in the <i>2003 Hazardous Waste Report, Instructions and Forms</i> or ''
GM230	GM-1-D	If source code equals G25 then the management method code must be a management method specified in the <i>2003 Hazardous Waste Report, Instructions and Forms</i> . If source code is not equal to G25 then the management method code must be blank.	If SOURCE_TYPE = 'G25' Then ORIGIN_MANAGEMENT_METHOD = value specified in the <i>2003 Hazardous Waste Report, Instructions and Forms</i> Else ORIGIN_MANAGEMENT_METHOD = ''
GM270	GM-1-D	The source code must be a source code value specified in the <i>2003 Hazardous Waste Report, Instructions and Forms</i> .	SOURCE_CODE = value specified in the <i>2003 Hazardous Waste Report, Instructions and Forms</i>
GM280	GM	GM3 record is present, but corresponding record does not exist in the GM1 file.	HANDLER_ID and HZ_PG in GM1 file
GM300	GM-1-C	Waste code must be registered with the RCRAInfo database.	WASTE_CODE = implementer defined state waste code in LU_WASTE_CODE

Edit Number	Form Location	Edit Description	Select Logic
GM310		If Include in National Report in the SI1 file equals 'N' then Include in National Report must be a 'N'. If Include in National Report in the SI1 file equals 'Y' then Include in National Report must be a 'Y' or 'N'.	If INCLUDE_IN_NATIONAL_REPORT = 'N' in the SI1 file Then INCLUDE_IN_NATIONAL_REPORT = 'N' Else INCLUDE_IN_NATIONAL_REPORT = 'Y' or 'N'
GM320	GM-2	On-site management indicator must equal 'Y' or 'N'	ON_SITE_MANAGEMENT = 'Y' or 'N'
GM330	GM-2	If On-site management indicator equals 'Y' then at least one corresponding record must exist in GM5 file.	If ON_SITE_MANAGEMENT = 'Y' Then HANDLER_ID and HZ_PG in GM5 file
GM335	GM-2	If On-site management indicator equals 'N' then no corresponding record may exist in GM5 file.	If ON_SITE_MANAGEMENT = 'N' Then no record in GM5 file for HANDLER_ID and HZ_PG
GM340	GM-3-A	Off-site management indicator must equal 'Y' or 'N'	OFF_SITE_SHIPMENT = 'Y' or 'N'
GM350	GM-3-A	If Off-site shipment indicator equals 'Y' then at least one corresponding record must exist in GM4 file.	If OFF_SITE_SHIPMENT = 'Y' Then HANDLER_ID and HZ_PG in GM4 file
GM355	GM-3-A	If Off-site shipment indicator equals 'N' then no corresponding record may exist in GM4 file.	If OFF_SITE_SHIPMENT = 'N' Then no record in GM4 for HANDLER_ID and HZ_PG

C.5 Form WR Edits

Edit Number	Form Location	Edit Description	Select Logic
WR000	WR	WR1 record is present, but corresponding record does not exist in the SI1 file.	HANDLER_ID in SI1file
WR010	WR	Page number must be greater than zero.	HZ_PG > 0
WR020	WR	Sub-page number must equal '1', '2', or '3'.	SUB_PG_NUM = '1' or '2' or '3'
WR030	WR-F	Generated quantity unit of measure must equal '1', '2', '3', '4', '5', '6', or '7'.	UNIT_OF_MEASURE = '1' or '2' or '3' or '4' or '5' or '6' or '7'
WR040	WR-F	If the generated quantity unit of measure is '5', '6' or '7' then density must be greater than zero and density unit of measure must be 1 or 2.	If UNIT_OF_MEASURE = '5', '6', or '7' Then WST_DENSITY > 0 AND DENSITY_UNIT_OF_MEASURE = 1 or 2
WR050	WR-F	Waste density must be greater than or equal to 0.01 and less than or equal to 999.99, or equal to 0.	WST_DENSITY >= 0.01 and <= 999.99 or WST_DENSITY = 0
WR060	WR-H	Management method code must be a management method specified in the <i>2003 Hazardous Waste Report, Instructions and Forms</i> .	MANAGEMENT_METHOD = value specified in the <i>2003 Hazardous Waste Report, Instructions and Forms</i>
WR070	WR-D	The first two characters of the off-site handler EPA ID number must be a valid postal code (see Appendix F) or 'FC' (foreign country).	SUBSTR(IO_TDR_ID,1,2) = valid postal code (see Appendix F) or 'FC'
WR080	WR-E	Total quantity received in the reporting year must be greater than or equal to 0.000001 and less than or equal to 99,999,999,998.999999.	IO_TDR_QTY >= 0.000001 and <= 99999999998.999999
WR090	WR	WR2 record is present, but corresponding record does not exist in the WR1 file.	HANDLER_ID, HZ_PG, and SUB_PG_NUM in WR1 file
WR110	WR-B	EPA hazardous waste code must be an EPA waste code specified in the <i>2003 Hazardous Waste Report, Instructions and Forms</i> .	EPA_WASTE_CODE = value specified in the <i>2003 Hazardous Waste Report, Instructions and Forms</i>
WR130	WR-B	EPA or State hazardous waste data must be provided.	HANDLER_ID, HZ_PG, and SUB_PG_NUM in WR1 file and in WR2 or WR3 file

Edit Number	Form Location	Edit Description	Select Logic
WR180	WR-G	The form code must be a form code specified in the <i>2003 Hazardous Waste Report, Instructions and Forms</i> or blank.	FORM_CODE = value specified in the <i>2003 Hazardous Waste Report, Instructions and Forms</i> or ''
WR200	WR	WR3 record is present, but corresponding record does not exist in the WR1 file.	HANDLER_ID, HZ_PG, and SUB_PG_NUM in WR1 file
WR220	WR-B	Waste code must be registered with the RCRAInfo database.	WASTE_CODE = implementer defined value in LU_WASTE_CODE
WR230		If Include in National Report in the SI1 file equals 'N' then Include in National Report must be 'N'. If Include in National Report in the SI1 file equals 'Y' then Include in National Report must be 'Y' or 'N'.	If INCLUDE_IN_NATIONAL_REPORT = 'N' in the SI1 file Then INCLUDE_IN_NATIONAL_REPORT = 'N' Else INCLUDE_IN_NATIONAL_REPORT = 'Y' or 'N'

APPENDIX D

Hazardous Waste Report Annotated Forms

9. Operator and Legal Owner of the Site (See pages xx to xx)	A. Name of Site's Operator: SI9-4		Date Became Operator (mm/dd/yyyy): SI9-5
	Operator Type: <input type="checkbox"/> Private <input type="checkbox"/> County <input type="checkbox"/> District <input type="checkbox"/> Federal <input type="checkbox"/> Indian <input type="checkbox"/> Municipal <input type="checkbox"/> State <input type="checkbox"/> Other SI9-6		
	B. Name of Site's Legal Owner: SI9-4		Date Became Owner (mm/dd/yyyy): SI9-5
	Owner Type: <input type="checkbox"/> Private <input type="checkbox"/> County <input type="checkbox"/> District <input type="checkbox"/> Federal <input type="checkbox"/> Indian <input type="checkbox"/> Municipal <input type="checkbox"/> State <input type="checkbox"/> Other SI9-6		
	Street or P. O. Box: SI9-7, SI9-8, SI9-9		
	City: SI9-10		
	State: SI9-11		
	Country: SI9-13		Zip Code: SI9-12

10. Type of Regulated Waste Activity
Mark Yes or No for all activities; complete any additional boxes as instructed. (See instructions on pages xx to xx.)

A. Hazardous Waste Activities
Complete all parts for 1 through 6.

<p>Y <input type="checkbox"/> N <input type="checkbox"/> 1. Generator of Hazardous Waste If Yes, choose only one of the following - a, b, or c. SI1-25</p> <p><input type="checkbox"/> a. LQG: Greater than 1,000 kg/mo (2,200 lbs./mo.) of non-acute hazardous waste; or</p> <p><input type="checkbox"/> b. SQG: 100 to 1,000 kg/mo (220 - 2,200 lbs./mo.) of non-acute hazardous waste; or</p> <p><input type="checkbox"/> c. CESQG: Less than 100 kg/mo (220 lbs./mo.) of non-acute hazardous waste</p> <p>In addition, indicate other generator activities.</p> <p>Y <input type="checkbox"/> N <input type="checkbox"/> d. United States Importer of Hazardous Waste SI1-26</p> <p>Y <input type="checkbox"/> N <input type="checkbox"/> e. Mixed Waste (hazardous and radioactive) Generator SI1-27</p>	<p>Y <input type="checkbox"/> N <input type="checkbox"/> 2. Transporter of Hazardous Waste SI1-28</p> <p>Y <input type="checkbox"/> N <input type="checkbox"/> 3. Treater, Storer, or Disposer of Hazardous Waste (at your site) Note: A hazardous waste permit is required for this activity. SI1-29</p> <p>Y <input type="checkbox"/> N <input type="checkbox"/> 4. Recycler of Hazardous Waste (at your site) SI1-30</p> <p>Y <input type="checkbox"/> N <input type="checkbox"/> 5. Exempt Boiler and/or Industrial Furnace If Yes, mark each that applies.</p> <p><input type="checkbox"/> a. Small Quantity On-site Burner Exemption SI1-31</p> <p><input type="checkbox"/> b. Smelting, Melting, and Refining Furnace Exemption SI1-32</p> <p>Y <input type="checkbox"/> N <input type="checkbox"/> 6. Underground Injection Control SI1-33</p>
--	---

<p>B. Universal Waste Activities</p> <p>Y <input type="checkbox"/> N <input type="checkbox"/> 1. Large Quantity Handler of Universal Waste (accumulate 5,000 kg or more) [refer to your State regulations to determine what is regulated]. Indicate types of universal waste mark all boxes that apply:</p> <table style="width:100%; margin-left: 40px;"> <tr> <td></td> <td style="text-align: center;"><u>Generate</u></td> <td style="text-align: center;"><u>Accumulate</u></td> </tr> <tr> <td>a. Batteries</td> <td style="text-align: center;"><input type="checkbox"/> SI2-2</td> <td style="text-align: center;"><input type="checkbox"/> SI2-3</td> </tr> <tr> <td>b. Pesticides</td> <td style="text-align: center;"><input type="checkbox"/> SI2-4</td> <td style="text-align: center;"><input type="checkbox"/> SI2-5</td> </tr> <tr> <td>c. Thermostats</td> <td style="text-align: center;"><input type="checkbox"/> SI2-6</td> <td style="text-align: center;"><input type="checkbox"/> SI2-7</td> </tr> <tr> <td>d. Lamps</td> <td style="text-align: center;"><input type="checkbox"/> SI2-8</td> <td style="text-align: center;"><input type="checkbox"/> SI2-9</td> </tr> <tr> <td>e. Other (specify) <u>SI3-2</u></td> <td style="text-align: center;"><input type="checkbox"/> SI3-3</td> <td style="text-align: center;"><input type="checkbox"/> SI3-4</td> </tr> <tr> <td>f. Other (specify) _____</td> <td style="text-align: center;"><input type="checkbox"/></td> <td style="text-align: center;"><input type="checkbox"/></td> </tr> <tr> <td>g. Other (specify) _____</td> <td style="text-align: center;"><input type="checkbox"/></td> <td style="text-align: center;"><input type="checkbox"/></td> </tr> </table> <p>Y <input type="checkbox"/> N <input type="checkbox"/> 2. Destination Facility for Universal Waste Note: A hazardous waste permit may be required for this activity. SI2-10</p>		<u>Generate</u>	<u>Accumulate</u>	a. Batteries	<input type="checkbox"/> SI2-2	<input type="checkbox"/> SI2-3	b. Pesticides	<input type="checkbox"/> SI2-4	<input type="checkbox"/> SI2-5	c. Thermostats	<input type="checkbox"/> SI2-6	<input type="checkbox"/> SI2-7	d. Lamps	<input type="checkbox"/> SI2-8	<input type="checkbox"/> SI2-9	e. Other (specify) <u>SI3-2</u>	<input type="checkbox"/> SI3-3	<input type="checkbox"/> SI3-4	f. Other (specify) _____	<input type="checkbox"/>	<input type="checkbox"/>	g. Other (specify) _____	<input type="checkbox"/>	<input type="checkbox"/>	<p>C. Used Oil Activities Mark all boxes that apply.</p> <p>Y <input type="checkbox"/> N <input type="checkbox"/> 1. Used Oil Transporter If Yes, mark each that applies. <input type="checkbox"/> a. Transporter SI2-11 <input type="checkbox"/> b. Transfer Facility SI2-12</p> <p>Y <input type="checkbox"/> N <input type="checkbox"/> 2. Used Oil Processor and/or Re-refiner If Yes, mark each that applies. <input type="checkbox"/> a. Processor SI2-13 <input type="checkbox"/> b. Re-refiner SI2-14</p> <p>Y <input type="checkbox"/> N <input type="checkbox"/> 3. Off-Specification Used Oil Burner SI2-15</p> <p>Y <input type="checkbox"/> N <input type="checkbox"/> 4. Used Oil Fuel Marketer If Yes, mark each that applies. <input type="checkbox"/> a. Marketer Who Directs Shipment of Off-Specification Used Oil to Off-Specification Used Oil Burner SI2-16 <input type="checkbox"/> b. Marketer Who First Claims the Used Oil Meets the Specifications SI2-17</p>
	<u>Generate</u>	<u>Accumulate</u>																							
a. Batteries	<input type="checkbox"/> SI2-2	<input type="checkbox"/> SI2-3																							
b. Pesticides	<input type="checkbox"/> SI2-4	<input type="checkbox"/> SI2-5																							
c. Thermostats	<input type="checkbox"/> SI2-6	<input type="checkbox"/> SI2-7																							
d. Lamps	<input type="checkbox"/> SI2-8	<input type="checkbox"/> SI2-9																							
e. Other (specify) <u>SI3-2</u>	<input type="checkbox"/> SI3-3	<input type="checkbox"/> SI3-4																							
f. Other (specify) _____	<input type="checkbox"/>	<input type="checkbox"/>																							
g. Other (specify) _____	<input type="checkbox"/>	<input type="checkbox"/>																							

11. Description of Hazardous Wastes (See instructions on page xx)

A. Waste Codes for Federally Regulated Hazardous Wastes. Please list the waste codes of the Federal hazardous wastes handled at your site. List them in the order they are presented in the regulations (e.g., D001, D003, F007, U112). Use an additional page if more spaces are needed.

SI4-2						

B. Waste Codes for State-Regulated (i.e., non-Federal) Hazardous Wastes. Please list the waste codes of the State-regulated hazardous wastes handled at your site. List them in the order they are presented in the regulations. Use an additional page if more spaces are needed for waste codes.

SI5-2						

12. Comments (See instructions on page xx)

SI1-35

13. Certification. I certify under penalty of law that this document and all attachments were prepared under my direction or supervision in accordance with a system designed to assure that qualified personnel properly gather and evaluate the information submitted. Based on my inquiry of the person or persons who manage the system, or those persons directly responsible for gathering the information, the information submitted is, to the best of my knowledge and belief, true, accurate, and complete. I am aware that there are significant penalties for submitting false information, including the possibility of fine and imprisonment for knowing violations.
(See instructions on page xx)

Signature of owner, operator, or an authorized representative	Name and Official Title (type or print)	Date Signed (mm/dd/yyyy)
	SI7-3, SI7-4, SI7-5, SI7-6	SI7-7

APPENDIX E

FLAT FILE HIERARCHY

APPENDIX E - Flat File Hierarchy

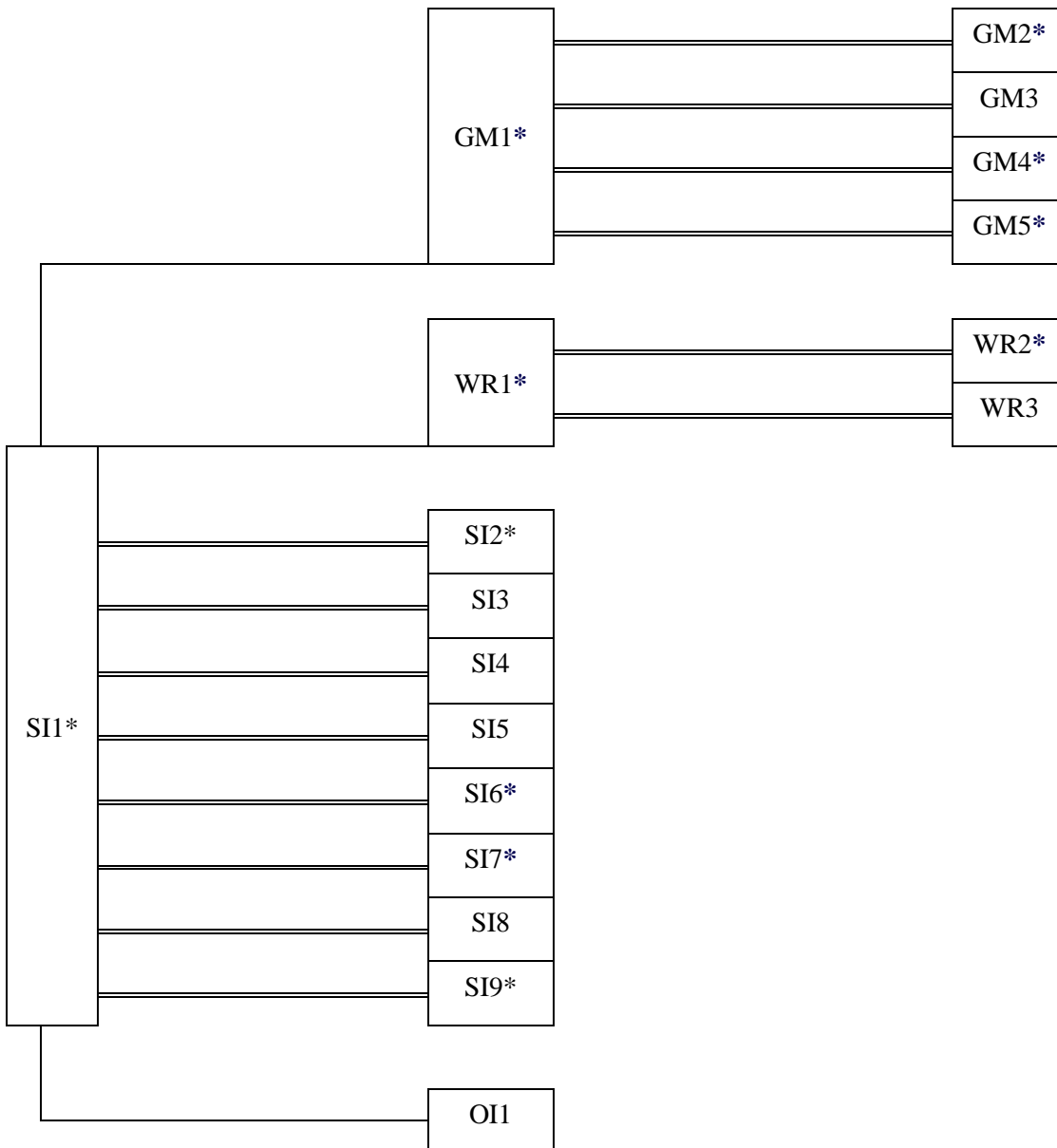

* These flat files contain required data elements.

NOTE: The OI1 flat file should never be included in the submission to RCRAInfo.

APPENDIX F
State Postal Codes

APPENDIX F - State Postal Codes

State Name	Postal Code	State Name	Postal Code	State Name	Postal Code
Alabama	AL	Kentucky	KY	Ohio	OH
Alaska	AK	Louisiana	LA	Oklahoma	OK
American Samoa	AS	Maine	ME	Oregon	OR
Arizona	AZ	Maryland	MD	Pennsylvania	PA
Arkansas	AR	Massachusetts	MA	Puerto Rico	PR
California	CA	Michigan	MI	Rhode Island	RI
Colorado	CO	Minnesota	MN	South Carolina	SC
Connecticut	CT	Mississippi	MS	South Dakota	SD
Delaware	DE	Missouri	MO	Tennessee	TN
District of Columbia	DC	Montana	MT	Texas	TX
Florida	FL	Navajo Nation	NN	Trust Territories	TT
Georgia	GA	Nebraska	NE	Utah	UT
Guam	GU	Nevada	NV	Vermont	VT
Hawaii	HI	New Hampshire	NH	Virgin Islands	VI
Idaho	ID	New Jersey	NJ	Virginia	VA
Illinois	IL	New Mexico	NM	Washington	WA
Indiana	IN	New York	NY	West Virginia	WV
Iowa	IA	North Carolina	NC	Wisconsin	WI
Kansas	KS	North Dakota	ND	Wyoming	WY

End of document.