Peer Review of the Greenhouse Gas Emissions Model (GEM) and EPA's Response to Comments

Peer Review of the Greenhouse Gas Emissions Model (GEM) and EPA's Response to Comments

Assessment and Standards Division
Office of Transportation and Air Quality
U.S. Environmental Protection Agency

Sections prepared for EPA by
Research Triangle Institute International
EPA Contract No. EP-C-08-008
Work Assignment No. 3-02

NOTICE

This technical report does not necessarily represent final EPA decisions or positions. It is intended to present technical analysis of issues using data that are currently available. The purpose in the release of such reports is to facilitate the exchange of technical information and to inform the public of technical developments.

Table of Contents

- I. RTI's Technical Report of the Peer Review of EPA's Greenhouse gas Emissions Model (GEM)
 1. Background
 2. Description of Peer Review Process
 3. Summary of Peer Review Comments
 4. Background Materials

- II. Appendices
 1. Appendix A: Charge Questions
 2. Reviewer Resumes
 3. Cover Letters
 4. Individual Peer Reviews
 - i. Aris Babajimopoulos
 - ii. Daniel L. Flowers
 - iii. Shawn Midlam-Mohler
 - iv. Elliott Ortiz-Soto

- III. EPA's Response to Peer Reviewer Comments

TO: Kent Helmer, Chien Sze, U.S. Environmental Protection Agency, Office of Transportation and Air Quality (OTAQ)

FROM: Tony Lentz, Paramita Sinha, and Karen Schaffner, RTI

DATE: January 28, 2011

SUBJECT: Peer Review of EPA's Heavy-Duty Greenhouse Gas Emission Model (GEM)

1. Background

EPA and the National Highway Traffic Safety Administration are considering a first-ever program to reduce GHG emissions and improve fuel efficiency in the heavy-duty highway vehicle sector. This broad vehicle sector, ranging from large pickups to sleeper-cab tractors (Classes 2b through 8), represents the second largest contributor to transportation GHG emissions after light-duty passenger cars and trucks. The agencies are proposing to evaluate both fuel consumption and CO₂ emissions from heavy-duty highway vehicles through a whole-vehicle operation simulation model.

EPA has created a model called "Greenhouse Gas Emissions Model (GEM)," which is specifically tailored to predict truck GHG emissions. As the model is designed for the express purpose of vehicle compliance demonstration, it is less configurable than similar commercial products and its only outputs are GHG emissions and fuel consumption. This approach gives a simple and compact tool for vehicle compliance without the overhead and costs of a more sophisticated model.

To assure that the regulated community gets the highest quality predictive tools that EPA can provide and to assure its stakeholders that the proposed model structure (and overall development process) will result in a tool that is simple, accurate and well suited for certification, EPA sought an independent peer review of its GEM model.

2. Description of Review Process

EPA's Office of Transportation and Air Quality (OTAQ) contacted RTI International in October of 2010 to facilitate the peer review of its Heavy-Duty Greenhouse Gas Emission Model (GEM).

RTI began the review process on October 19, 2010 and concluded January 21, 2011, a period of slightly more than 3 months.

EPA provided a short list of subject matter experts from academia and the public sector (Appendix B of the work assignment 3-02) to RTI, and this served as a “starting point” from which we assembled the list of subject matter experts. RTI selected three¹ independent (as defined in Sections 1.2.6 and 1.2.7 of EPA’s Peer Review Handbook) subject matter experts to conduct the requested reviews. Subject matter experts familiar with MATLAB, Simulink, Stateflow and Visual Basics software, as well as having expertise in vehicle operations and analysis, linkages between mobile source emission modeling and transportation modeling and planning, or application of current mobile source emissions models for analysis for regulatory purposes were selected.

To ensure that the review process was conducted in a timely manner, RTI contacted potential reviewers within 10 days of submitting the work plan and determined that each reviewer would be able to perform work during the period of performance. To make the review process as credible as possible, RTI did not consult the Agency in the final determination of reviewers. RTI obtained the resumes of the selected reviewers, and these are included in Appendix B.

EPA provided RTI with the necessary model review material via email on November 12, 2010². This was forwarded to the reviewers; and in addition to the review material, RTI forwarded a set of charge questions prepared by the EPA (these questions were later revised).

On November 17, 2010, RTI organized and held a teleconference between EPA, the three reviewers, and RTI to provide an opportunity to the panel to discuss any questions or concerns they may have regarding the material provided and expected deliverables. The call concluded when all participants’ questions and concerns were addressed and a mutually agreed upon deliverable date was set. Based on the discussion during the call, EPA sent RTI an updated set of charge questions on November 23, 2010 and this was forwarded to the reviewers on November 29, 2010. These charge questions are included in Appendix A of this memorandum.

Following the first bi-monthly progress report call between RTI and EPA (November 16, 2010) and subsequent email correspondence (November 18, 2010), it was also agreed upon that a fourth subject matter expert should be identified and selected as a reviewer. EPA sent RTI an expanded short list from which the fourth reviewer was identified and contacted by RTI. The

¹ Initially, RTI identified 3 subject matter experts to serve as reviewers. Following the first bi-monthly progress report call between RTI and EPA, it was agreed upon that a fourth subject matter expert should be identified and selected as a reviewer.

² EPA distributed all the necessary review material to RTI in an email, which contained hyperlinks (“weblinks”) to the review material along with weblinks to both, the executable and MATLAB/Simulink, versions of the GEM and an accompanying model guide.

necessary material and charge questions were forwarded to him upon his acceptance to participate in this peer review.

Completed reviews from the panel were sent to EPA on Wednesday, December 22, 2010. These reviews included the response to the charge questions and any additional comments the reviewer may have had (e.g., margin notes on review materials). RTI also obtained a cover letter from each reviewer stating the reviewer's name; the name and address of their organization if applicable; and a statement of any real or perceived conflict(s) of interest. The cover letters and reviews are included in Appendices C and D, respectively. EPA's comments in response to the reviewers' assessments are included in Appendix E.

3. Summary of Review Comments

Aristotelis Babajimopoulos (University of Michigan, College of Engineering), Dan Flowers (Lawrence Livermore National Laboratory, Combustion and Alternative Fuels, E Program), Shawn Midlam-Mohler (Ohio State University, Department of Mechanical Engineering), and Elliott Ortiz-Soto (University of Michigan, College of Engineering) reviewed EPA's GEM. This section provides a summary of the comments received from them.

3.1 EPA'S OVERALL APPROACH TO THE STATED PURPOSE OF THE MODEL (MEET AGENCIES' COMPLIANCE REQUIREMENTS) AND WHETHER THE PARTICULAR ATTRIBUTES FOUND IN RESULTING MODEL EMBODIES THAT PURPOSE.

All four reviews addressed the model's ability to meet the agencies' compliance requirements. One reviewer explicitly detailed whether the model's particular attributes embody the stated purpose of the model. In general, the reviewers reported that the model does an acceptable job testing different vehicle configurations from different vehicle manufacturers for compliance purposes.

Dr. Flowers comments, "Overall, the concept of using a generic vehicle model has merit to limit the need to test the myriad possible vehicle configurations. The use of a generic powertrain (engine and transmission) is problematic because a well-integrated powertrain can significantly improve vehicle performance." (Additional discussion of powertrain issues are provided in subsection 3.2.1 below.)

Dr. Babajimopoulos remarks, “GEM is a very detailed vehicle simulation that could capture with reasonable accuracy the impact of changes in aerodynamic drag coefficient, tire rolling resistance and tire weight reduction on overall vehicle fuel economy and CO₂ emissions. The model itself is almost too detailed for this purpose, but this should not be a problem, provided that not all details of the model are discussed in such great length with the users. However... it is hard to envision a compliance tool that does not account for fuel economy improvements coming from the development of advanced combustion technologies by the engine manufacturers.”

Dr. Midlam-Mohler addresses the five modeling attributes³ needed for the model to serve as a primary compliance tool. Regarding each attribute, he comments:

1. “The model fidelity of the type proposed should be capable of achieving the desired objectives. The model reviewed, however, has a number of issues which cast doubt upon the specific implementation of the model. Specifically, a number of issues were found in the electrical subsystem as well as the engine subsystem.”
2. “Providing source code as a Simulink diagram is necessary for this objective but not sufficient. Additional documentation on the equations and references behind the Simulink code should be developed and released to the public.”
3. “The compiled version of the code is free and easy to use. The Simulink version requires a Matlab license which is not free but fairly common in industry.”
4. “The current structure satisfied this objective.”
5. “By releasing an official and unalterable executable version of the model this objective is met.”

While Mr. Ortiz-Soto provides specific comments on multiple aspects of the model (including comments on inputs, outputs, model and submodels, see sections below for details), he also notes that “In general, the rest of the model looks good.” Mr. Ortiz-Soto reports, “Overall, the model is in great shape and should be a strong starting point for a dedicated simulation oriented to compliance purposes.”

³ The five attributes listed in EPA’s updated charge questions are: 1) capable of modeling a wide array of medium- and heavy-duty vehicles over different drive cycles; 2) contains open source code, providing transparency in the model’s operation; 3) freely available and easy to use by any user with minimal or no prior experience; 4) contains both optional and preset elements; and 5) managed by the Agencies for compliance purposes.

3.2 THE APPROPRIATENESS AND COMPLETENESS OF THE CONTENTS OF THE OVERALL MODEL STRUCTURE AND ITS INDIVIDUAL SYSTEMS, AND THE COMPONENT MODELS, IF APPLICABLE (i.e., USING THE MATLAB/SIMULINK VERSION)

This section is broken down into 4 subsections with each subsection containing one or more comments from the reviews. In general, each reviewer commented on one or more of the following subsections.

3.2.1 The Elements of Each System to Describe Different Vehicle Categories

The GEM model has 6 systems (Driver, Ambient, Electric, Engine, Transmission, and Vehicle) used to describe different vehicle categories. There was little, to no, discussion among the reviewers concerning 2 systems, the ambient and driver systems. In the remaining four systems (electric, engine, transmission, and vehicle), the reviewers found errors and identified issues that raised questions about the overall ability of the systems to accurately depict different vehicle categories.

Dr. Babajimopoulos details issues with the component models of the engine, transmission and vehicle systems. He comments, "...engine fuel maps and drivetrain parameters are hardwired in the model and the user has no option of changing them. However, it seems counterintuitive that a tool for determining compliance with emissions standards would ignore efforts on the part of the manufacturers to make improvements on the engine itself. Moreover, in order to take full advantage of any improvements in combustion and engine-out emissions, the vehicle transmission needs to be optimized for a particular vehicle/engine/driving schedule combination, so that the engine can operate near its optimum efficiency points at all times."

Dr. Flowers noted that in the GEM model, "the engine and transmission is not optimized to the vehicle" and "The use of a generic powertrain (engine and transmission) is problematic because a well-integrated powertrain can significantly improve vehicle performance." "In practice, the engine and transmission can be appropriately sized to best take advantage of the reduced overall vehicle load. By requiring only one engine and transmission be used, drag reduction efforts could be penalized."

Mr. Soto also commented on the engine fuel maps. He stated that "One of the most important input dat[um] for a fuel economy drive-cycle simulation is the engine mechanical load and fuel consumption maps. The mechanical load maps are usually simple because only the WOT (or Diesel equivalent) values are required, but obtaining full range fuel consumption values is much more difficult. Several engine maps appear to be available for each vehicle class, but making

these completely standard with a prescribed displacement volume and operating range might be a limiting factor for some manufacturers. A more flexible approach would be to have normalized load and fuel consumption maps, given in BMEP and BSFC values. The current maps can be easily converted into BMEP and BSFC with the data available. The user could then provide the engine displacement and possibly another key parameter such as rated torque or power and the engine speed, and an algorithm could automatically manipulate the normalized maps to obtain more representative absolute values for the engine in question. Even though this compliance tool assumes that the engines have already been certified, the fuel economy and CO₂ values that the simulation predicts are directly related to the maps given, and manufacturers might want to ensure the engines in their vehicles are properly accounted for.”

Dr. Flowers conducted a comparison of the GEM model output values and direct calculated values for the same parameters for a particular vehicle configuration and drive cycles. He determined that the direct calculated torque is 3 percent lower than the GEM-modeled torque, and noted a possible explanation may be due to the speed variation during the constant desired speed portion of the drive cycle. Referring to the chassis component model contained in the vehicle system, Dr. Flowers reports that the powertrain inertial mass should be zero during a certain drive cycle. He states, “The GEM model uses an “effective mass” formulation that includes powertrain inertial effects. In the GEM code, the vehicle static mass (vehicle.chsmass_static) is added to the representative powertrain inertial mass (tire_mass_out). For steady speed vehicle operation the powertrain inertial mass should be zero.” Dr. Flowers compared GEM model output values and calculated values for fuel usage, fuel consumption, and GHG emissions (using GEM output values for torque and speed), and he noted that errors were small (less than 0.3 percent).

Dr. Midlam-Mohler summarizes his comments of the model systems and their underlying components models by stating, “The overall approach of using a relatively simple model structure based in Matlab-Simulink is sound provided that models are calibrated and validated to a sufficient level.”

Dr. Midlam-Mohler stated that some issues in the Engine subsystem need to be addressed and he stated “The method of handling negative brake torques in the model does not seem to be appropriate.” Dr. Midlam-Mohler notes that “A map-based engine model should be sufficient to achieve the desired objectives. The engine model implemented in the current version of the software does not appear to be as well implemented as it could be. Given the importance of this in the overall objectives of the simulator this needs to be addressed. Using fuel maps which have torque indices ranging from a negative brake torque to the maximum rated torque would alleviate much of the uncertainty in the model. Driver accelerator requests should then be linearly scaled from minimum value to the maximum value on this map with the exception of idle conditions in

which alternative measure must be taken. This approach also automatically takes into account deceleration fuel cut-off as well.”

Dr. Midlam-Mohler notes some recommendations for the Vehicle subsystem, stating “The most serious item is considered to be the fact that the “Vehicle Weight Reduction” parameter is specifically cited as being able to model light-weight wheels. The existing model structure would not accurately do this as it does not take into account the inertial aspect of the wheels which would have a greater impact on the vehicle.”

Dr. Midlam-Mohler noted that in the Driver subsystem, the PID values are fixed in the GEM model but that it may be worth adding this as an advance feature or using a more sophisticated control concept, such as augment the current PID control with a feedforward component. He did note that large errors in velocity tracking were not observed in the model.

Mr. Ortiz-Soto notes that “Control for most of the vehicle components seems to be achieved by fairly standard PID controllers. Usually the gains for these controllers are tuned to a specific plant, but in this case they remain fixed for all the vehicle configurations. Were these gains tuned for all the plants individually and then somehow averaged to account for all of them, or were they computed for a single vehicle? Although for the test cases do not show any major problems with following the prescribed velocity profile, simulation of some vehicles or with a different set of parameters could possibly suffer if the controller gains are not appropriate. For the driver, for example, more elaborate, robust and reusable driver models exist, and it might [be] useful to investigate the possibility of incorporating one of these in order to avoid possible issues with the simulations.”

3.2.2 The Performance of Each Component Model, Including the Reviewer’s Assessment of the Underlying Equations and/or Physical Principles Coded into That Component

Four of the GEM model systems (electric, engine, transmission and vehicle) are made up of underlying component models. The reviewers assessed the performance of those component models, including the equations and physical principles of the component model, and reported their findings. Each reviewer noted that one or more of the component models performed inadequately and recommended these component model inadequacies be addressed to improve the robustness of the compliance tool. Additionally, a couple of the reviewers identified non-trivial errors in the equations of some of the component models. For example, one reviewer states, “A number of errors were found in models within GEM. None of these errors are expected to contribute to larger errors to the output results but should be corrected nonetheless.”

Three of the reviewers commented on flaws in the electric system.

Dr. Babajimopoulos reports, “The model of the electric subsystem is particularly detailed and convoluted. GEM includes submodels for the starter, alternator, battery and electric accessories. This complexity seems unnecessary for the stated purposes of GEM. Careful examination of the results reveals that the starter has almost zero effect on overall fuel economy and CO₂ emissions. Moreover, the overall effect of the electrical system on fuel economy and CO₂ emissions is almost negligible.”

Dr. Midlam-Mohler comments, “Very significant issues were found in the electric subsystem which require attention. In particular, the battery model appears to [have] an error which causes battery voltage to decrease with battery state of charge which is exactly opposite of the desired behavior. Furthermore, it appears that the sign convention used for the starter, accessories, alternator have the wrong sense. The alternator generates negative current which decreases SOC. The other two currents, which are current sinks, actually increase the SOC of the battery. Even with the above issues aside, the alternator model appears to not consider the mechanical to electrical efficiency of the device and the control is naïve of actual alternator capabilities and control.”

Mr. Ortiz-Soto comments, “The electric components and EES seem to be fixed for all the vehicles in the simulation, but in reality the electrical system is probably designed for a given application to account for the particular load requirements. It is understandable that due to the complexity of acquiring parameters such as these, the system model is standardized, but it could also result in simulation inaccuracies. It might be more appropriate to provide at least some basic scaling capability for the overall electrical system so that with one or two additional inputs, the electrical components and EES are scaled to match the actual setup more closely.” “A similar observation can be made regarding the starter and alternator models.” While these are not critical components, a scaling factor should be applied.

Dr. Babajimopoulos found that the density of air value in the ambient system “seems to be rather low” and could impact model results in a non-trivial fashion depending on the cycle.

3.2.3 The Input and Output Structures and How They Interface with the Model to Obtain the Expected Result; i.e., Fuel Consumption and CO₂ over the Given Driving Cycles

Overall, the reviewers commented the input and output structures interfaced well with the model to obtain the expected results. Several reviewers offered minor suggestions that could help the end user when using the model. These suggestions are found in subsection 3.6.1 of this report.

3.2.4 The Default Values Used for the Input Files, as Shown in the GEM User Guide

All of the reviewers commented that the default values for the input files should be allowed to change to reflect manufacturer improvements. The reviewers' comments reflect a concern that the model does not allow for sufficient flexibility in certain respects. For example, Dr. Flowers expresses his concern about standardization when he remarks, "My main concern with the overall approach is the standardization of the vehicle and powertrain combination. This seems to have the potential to devalue efforts towards vehicle and powertrain integration and optimization towards GHG reduction."

Dr. Midlam-Mohler recommends that EPA allow some of the model parameters to change with respect to vehicle class. He suggests, "A number of parameters were noted which should change with respect to the vehicle class. The reviewer is certain that there are others that were not noted in this review. It is recommended that the EPA investigate this and take an appropriate action. In many cases, these components will not have a serious impact on the overall performance of the vehicle. By way of example, many of the inertias simulated in the model will not have a large impact on the results in contrast to the large inertia of the vehicle. If this is the case, then these inertias could be discarded from the model with little impact on performance. If the detailed inertias remain in the model, then they should accurately reflect the vehicle class."

Given the overall importance of fuel consumption and CO₂ emissions to the model's objective, three reviewers specifically address the engine maps default values.

Dr. Babajimopoulos commented, "If the assumption is that engines will be relatively similar for the same class vehicles coming from different manufacturers, then it is safe to assume that GEM would be an appropriate tool for determining compliance with fuel economy and CO₂ emissions standards based on vehicle design changes alone. Nevertheless, it would be proper to allow for the provision to change the engine fuel map and transmission characteristics used by GEM."

Mr. Ortiz-Soto and Dr. Midlam-Mohler provide comments on the default values for the engine fuel maps in subsection of 3.2.1 of this report.

3.3 USING THE STANDARD OF GOOD ENGINEERING JUDGMENT, THE PROGRAM EXECUTION IS OPTIMIZED BY THE CHOSEN METHODOLOGIES

One reviewer commented that he interprets this statement to be referring to "the performance of the code as an effective tool for this application [regulatory application]." The reviewer states the code seems to be developed in such a way that it provides detail on both the vehicle and

powertrain dynamics. Because the model is complex and is a “highly interconnected system,” he expresses concern about the model documentation and believes more detail should be provided about the physical models implemented. He feels that transparency in the details of the model is important for regulatory application and the model may suffer without sufficient detailing of the underlying physics and engineering assumptions.

3.4 CLARITY, COMPLETENESS AND ACCURACY OF THE OUTPUT/RESULTS (CO₂ EMISSIONS OR FUEL EFFICIENCY OUTPUT FILE)

Two reviewers stated the model output was clear and one commented that it was complete. One reviewer added, “The four tab format with the first tab being summary data and others being cycle data was sufficient.” A second review concluded, “The model reports the individual drive-cycle results and weighted average results, which is what is most important to the end user.” The reviewer added, “All the inputs needed to reproduce the results are reported.”

Two reviewers express concern about the clarity of the results with respect to the output file naming scheme.

Mr. Ortiz-Soto comments, “...naming the files based on date and time is not very useful or descriptive. When multiple simulations are performed, it becomes difficult to determine what file you should be looking into, unless you actually open it. The file names should include at least some sort of indication of what the simulation configuration was. The second problem I found was the lack of flexibility to specify where these output files are saved. There should be an option allowing the user to browse and select the main directory where these files are to be saved. As a final comment on this, there is really no reason for each of these files to be saved to a different folder if there is just a single output file. This simply adds an unnecessary layer to the file structure.”

Dr. Babajimopoulos raises a similar concern when he remarks, “It would be good if the message indicating where the results will be stored also include the drive (C:) in the path (e.g., ‘C:\GEM_Results\December_14_2010-0135PM instead of \GEM_Results\December_14_2010-0135PM).”

Regarding the accuracy of the output/results, Dr. Flowers indicates, “accuracy of the results is difficult to assess, since that requires specific comparison to experimental data to evaluate the performance of the model. Based on my testing efforts and experience, the results seem of reasonable magnitude for these kinds of vehicles.” Dr. Flowers concludes:

- “The model is quite detailed with regard to powertrain and vehicle dynamics. There is a danger here that imbedded assumptions can affect results in unexpected and undesirable ways. The example of the 3% difference in torque for analytical versus GEM simulation calculated torque for steady state operation may be indicative of these kinds of issues.”
- “Detailed description of the physics and assumptions imbedded in the models and submodels should be documented and made available to users.”
- “It may be worth considering if the model could be streamlined to provide greater clarity and transparency while still providing a tool for quantitatively estimating fuel consumption and GHG emissions.”

3.5 ANY RECOMMENDATIONS FOR SPECIFIC IMPROVEMENTS TO THE FUNCTIONING OR THE QUALITY OF THE OUTPUTS OF THE MODEL

The reviewers made several recommendations for improving the functioning and quality of the outputs. Two reviewer recommendations have been detailed in section 3.4 regarding the output file naming scheme. Additional reviewer recommendations are detailed below:

6. One reviewer recommends including additional results in the output. He believes, “It would be informative to have the fraction of each drive-cycle used in the average reported somewhere in the output.”
7. Dr. Midlam-Mohler suggests, “End users will likely want to see more detail in the output file than just the vehicle target speed and achieved speed. Making a limited number of “internal” parameters available to allow end users a glimpse inside the model without having to use Matlab-Simulink would be sufficient. These should be limited to things relevant to their inputs, such as aerodynamic drag over the cycle, rolling losses over the cycle, etc.”
8. Mr. Ortiz-Soto offers a couple recommendations for improving the quality of the outputs. He suggests for compliance purposes, “...it would be good to see the actual target value next to the simulation result, and probably some sort of percentage difference between these. It would give the manufacturer/user an idea of how their product performs with respect to the expected regulation standard.” Mr. Ortiz-Soto also believes some additional results will be helpful when he recommends, “...some additional results might be helpful for manufacturers to determine if the simulation is representative of their vehicle. Because many model parameters and vehicle operating strategies have been standardized using internal assumptions and algorithms, the overall behavior of the vehicle in question could end up being very different from what the vehicle manufacturer actually observes. This can result in a significant over-estimation of fuel consumption and CO₂ emissions, and possibly non-compliance. For this reason, it is fair that the manufacturer be able to assess the validity of the

simulation without having to investigate the model in detail. This could be achieved by providing a series of additional results, which could be related to the engine operation over the drive-cycles, the shifting strategy, the electrical system, etc.” He noted that it not practical to have to close each plot in order to see the next one or to run another simulation; he suggested that a small table with drive output would be useful to see along with the plots. He suggested that plots of the engine map and shifting strategy be included, along with various drive-cycle visitation points plotted on the engine map.

3.6 OTHER COMMENTS

The following subsections contain additional reviewer comments.

3.6.1 “Input” Format

Multiple reviewers suggested improvements to the input boxes to streamline its ease for the user; suggestions included:

- “The coefficient of aerodynamic drag can only be specified with a pull-down list of values from 0.50 to 0.85, with step 0.05. As a result, not all intermediate values for Cd can be specified, including the recommended values provided by EPA in Table 5 (e.g. 0.69, 0.76, 0.81 etc.). Considering the significant impact of Cd on fuel economy and its importance in achieving compliance, the value of Cd should be allowed to be entered in a textbox.”
- “...it is not clear why there should be a dropdown menu for the “Coefficient of Aerodynamic Drag” parameter. Furthermore, the dropdown menu allows the values to be overwritten by the user, so the dropdown menu has no real purpose... A better approach would be to just provide a sample value in the parameter name to give the user an idea of what would be an expected input in the box. Basically, it should look something like the “Steer Tire RR” and “Drive Tire RR” input boxes.”
- One reviewer suggests that input boxes should become inactive (“grayed out”) when it is not desirable for those input values to be changed.
- “The windows executable version has predefined values for C_d in a dropdown menu with preset values in increments of 0.02. The C_d value should just be an entry box, like the C_rr values.”
- “The inputs for weight reduction, speed limiter, and idle reduction are not consistent between the matlab version and the windows executable. For example in the matlab version. In matlab, zero “Weight Reduction” defaults to “N/A,” which causes an error in the windows version. The windows version does not accept “N/A” for idle reduction.”
- “The location of the “Vehicle Model Year” dropdown menu is not intuitive. This is one of the most important parameters of the simulation and it is part of the inputs that

affects the results, but it has been grouped with the identification parameters. These should be separated as they currently are, but somehow the “Vehicle Model Year” was left in the top section.”

- “Having radial buttons with all of the vehicle configurations in the “Regulatory Class” section is not necessary. It occupies space and reduces the GUI’s flexibility to add other parameters in the future. This type of list is probably better addressed through the use of a drop down menu. It would reduce the profile of this parameter list, and it would show much more clearly what vehicle type is being used. Currently, closer attention has to be paid to the GUI to notice which radio button of the ten available is selected, whereas with the dropdown menu it is only necessary to read what is displayed.”

3.6.2 Further Validation of the GEM Model

Two reviewers remarked that further validation is needed to ensure confidence of the model results.

Dr. Midlam-Mohler addresses model validation in remarking, “Based on the issues noted in (2) [Parameter values for Different Vehicle Classes] above, it is important to validate the model across vehicle classes. Because the model structure is relatively low-fidelity it has a greater burden of proof when “extrapolating” results. To have confidence in the model some further level of validation should be conducted.”

Dr. Flowers comments, “It should be confirmed whether the various controllers in the GEM model are well tuned and result in a vehicle response consistent with empirical data.”

3.6.3 Uncertainty/Sensitivity Analysis

One reviewer suggests that a sensitivity analysis should be conducted to better understand the propagation of error in the input parameters. He recommends that, “It would be useful to have a better understanding [of] the propagation of error in the input parameters. For the proposed configuration for the class 8 high-roof sleeper cab the sensitivity of the CO₂ result to errors in Cd is approximately 50%. This implies that a 10% error in Cd will result in a 5% error in prediction of CO₂ emissions. For rolling resistance, the impact of a 10% error in the tire rolling resistance causes a 2.3% error in prediction of CO₂ emissions. These sensitivities should be compared to the reduction in CO₂ emissions required as well as the accuracy of the key input parameters in the model. This analysis would also be useful in determining which parameters might be superfluous with respect to the desired output. As discussed above, there are some models which likely have more complexity than necessary.”

The reviewer concludes, “A rigorous study of the sensitivity of key input parameters should be conducted. Our ability to measure and estimate input parameters is not perfect, hence, the output

of the model is affected by this uncertainty. If our ability to measure the coefficient of drag is +/- x.y % then that has an impact on the model output. This uncertainty can then be compared to required accuracy to make a judgment on the validity of this method at estimating green house gas emissions or fuel economy.”

3.6.4 Complexity, Detail, Depth of Some Parts Seem Unnecessary

A couple reviewers note that they believe the model has a level of detail and complexity that may be unnecessary for the stated purpose of the model.

Mr. Ortiz-Soto provides a couple of examples of detail that seem unnecessary. He reports, “Some blocks go into deeper levels unnecessarily. Examples can be found in the electrical system and in the driver models. Although the approach used in this model of grouping models into blocks based on their physical components or functionality is fairly intuitive, adding extra layers can also make the model more difficult to follow if done excessively.” Adding to this, he comments, “Some models, such as the electrical system, appear to be extremely complex and detailed for this type of dedicated simulation. Unless there is a particular reason, such as future extensions to GEM for hybrid-electric trucks or different drive-cycles, where such details are necessary, then the electrical system model can probably be stripped down substantially without sacrificing much fidelity in the simulation.”

Dr. Midlam-Mohler similarly reports, “...that there is a higher than necessary level of fidelity in many of the models.” He suggests, “EPA could reduce the complexity of many of the models with little impact on the accuracy of the simulation – this would then lead to a reduced set of parameters that vary with vehicle class and therefore need to be determined.” Following up on this he concludes, “Several of the sub-models had complexity that far outweighed their impact on the results. The battery was one such sub-model which also contained some serious errors in its formulation. Many of these models could be simplified which will also reduce the number of parameters required...”

3.6.5 User Guide

One reviewer provides comments on the user guide. The reviewer believes that the model description, as presented in the user guide, is too detailed and may “generate unnecessary confusion to the users of GEM.” He provides examples of “features of the model that are irrelevant and outside the scope of GEM, even though these features are present in the model.”

4. References

Environmental Protection Agency (EPA). “Greenhouse Gas Emissions Model (GEM) User Guide.” EPA-420-B-10-039, October 2010.

Environmental Protection Agency (EPA). “Draft Regulatory Impact Analysis: Proposed Rulemaking to Establish Greenhouse Gas Emissions Standards and Fuel Efficiency Standards for Medium- and Heavy-Duty Engines and Vehicles.” EPA-420-D-10-901, October 2010.

Environmental Protection Agency (EPA) and National Highway Traffic Safety Administration (NHTSA). “Preamble: Greenhouse Gas Emissions Standards and Fuel Efficiency Standards for Medium and Heavy-Duty Engines and Vehicles.” EPA-HQ-OAR-2010-0162; NHTSA-2010-0079, October 2010.

Environmental Protection Agency (EPA). “EPA and NHTSA Propose First-Ever Program to Reduce Greenhouse Gas Emissions and Improve Fuel Efficiency of Medium- and Heavy-Duty Vehicles: Regulatory Announcement.” EPA-420-F-10-901, October 2010.

APPENDICES

Appendix A. Elements to be addressed in the Review of EPA’s GEM model

(The model and its documentation can be downloaded from the EPA website at: <http://www.epa.gov/otaq/climate/regulations>. Background information, the pre-publication draft Preamble, Regulations and Regulatory Impact Analysis, can also be found on the same website.)

EPA’s vehicle simulation model, GEM, was created to serve as the primary tool to certify Class 7/8 combination tractors and Classes 2b – 8 vocational vehicles in meeting EPA’s and NHTSA’s proposed vehicle GHG emission levels and fuel efficiency requirements. As both agencies’ proposed compliance tool, GEM needed the following modeling attributes:

- 1) capable of modeling a wide array of medium- and heavy-duty vehicles over different drive cycles;
- 2) contains open source code, providing transparency in the model’s operation;
- 3) freely available and easy to use by any user with minimal or no prior experience;
- 4) contains both optional and preset elements; and
- 5) managed by the Agencies for compliance purposes.

The design of GEM parallels the proposed regulations, which focus on the application of technologies having the largest impact on reducing vehicle GHG emission reductions or fuel consumption in the 2014-2017 timeframe. For the given timeframe, the model would allow various inputs to characterize a vehicle’s properties (e.g., weight, aerodynamics, and rolling resistance) and predict how the vehicle would behave when it to be operated over a particular driving cycle.

EPA has validated GEM based on the chassis test results from “SmartWay”-certified tractors tested at the Southwest Research Institute. Since many aspects of one tractor configuration (such as the engine, transmission, axle configuration, tire sizes, and control systems) are similar to those used on a manufacturer’s sister models, the validation work conducted on these vehicles is representative of the other Class 8 tractors.

The input values needed for the simulation model (e.g., drag coefficient, tire rolling resistance coefficients, tire/wheel weight reduction, vehicle speed limiter and extended idle reduction technologies) are obtained as manufacturer testing or model default values. At the present time, the agencies are proposing test procedures for generating aerodynamic drag and tire rolling resistance coefficient inputs. Likewise, the agencies are proposing a range for vehicle speed limiter and default extended idle reduction technology benefit variables. All other aspects of vehicle conformation as defined by the agencies are fixed within the model and are not variable for the purpose of compliance.

After parameters are input to the graphical user interface, GEM predicts the individual and cycle-weighted fuel consumption and CO₂ emissions for three proposed test cycles – a Transient cycle, a 55 mph steady-state cruise cycle, and a 65 mph steady-state cruise cycle. The model can also be used to determine a level of technology necessary for a vehicle to meet a specified GHG standard and allows a manufacturer to estimate the benefits and costs of those changes to a

particular vehicle for that level of GHG reductions.

In general, EPA is looking for the reviewer's opinion of the concepts and methodologies upon which the model relies and whether or not the model can be expected to execute these algorithms correctly. Toward this end, we suggest that reviewers comment on the following items:

- 1) EPA's overall approach to the stated purpose of the model (meet agencies' compliance requirements) and whether the particular attributes found in resulting model embodies that purpose.
- 2) The appropriateness and completeness of the contents of the overall model structure and its individual systems, and their component models, if applicable (i.e., using the MATLAB/Simulink version), such as:
 - a) The elements of each system to describe different vehicle categories;
 - b) The performance of each component model, including the reviewer's assessment of the underlying equations and/or physical principles coded into that component.
 - c) The input and output structures and how they interface with the model to obtain the expected result, i.e., fuel consumption and CO₂ over the given driving cycles; and
 - d) The default values used for the input file, as shown in the GEM User Guide.
- 3) Using the standard of good engineering judgment, the program execution is optimized by the chosen methodologies;
- 4) Clarity, completeness and accuracy of the output/results (CO₂ emissions or fuel efficiency output file); and
- 5) Any recommendations for specific improvements to the functioning or the quality of the outputs of the model.

In making comments to the model, reviewers should distinguish between recommendations for clearly defined improvements that can be readily made based on data or literature reasonably available to EPA and improvements that are more exploratory or dependent on information not readily available to EPA. Any comment(s) should be sufficiently clear and detailed to allow a thorough understanding by EPA or other parties familiar with the model. EPA would appreciate the reviewers not releasing any peer review materials or their comments to the public until the Agency makes its GEM model and supporting documentation public.

If a reviewer has questions as to what is required to complete this review or needs additional background materials, please have that person contact the RTI project manager. If a reviewer has a question about the EPA peer review process itself, please have that person contact Ms. Ruth Schenk in EPA's Quality Office by phone (734-214-4017) or e-mail schenk.ruth@epa.gov.

Curriculum Vitae: Aris Babajimopoulos

Personal

- Degrees
 - Ph.D. in Mechanical Engineering, February 2005 (conferred April 2005), The University of Michigan, Ann Arbor, MI
 - M.Sc. in Mechanical Engineering, August 2002, The University of Michigan, Ann Arbor, MI
 - Diploma in Mechanical Engineering, October 1998, Aristotle University of Thessaloniki, Thessaloniki, Greece
- Positions at the University of Michigan
 - Assistant Research Scientist, January 2006 – present
 - Research Fellow, February 2005 – January 2006
- Honors and Awards
 - 2006 SAE Excellence in Oral Presentation Award

Teaching

- **Ph.D. Committees**
 1. Mr. Michael Mosburger (member, chair: Volker Sick, Mechanical Engineering, expected 2011)
 2. Mr. Jerry Fuschetto (member, chair: Dennis Assanis, Mechanical Engineering, expected 2011)
 3. Dr. Jason Martz (member, chair: Dennis Assanis, Mechanical Engineering, October 2010)
 4. Dr. Seung Hwan Keum (member, co-chairs: Dennis Assanis and Hong Im, Mechanical Engineering, February 2009)
 5. Dr. Heejun Park (member, co-chairs: Dennis Assanis and Dohoy Jung, Mechanical Engineering, February 2009)
- **M.Sc. Committees**
 1. Mr. Prasad Shingne ((co-chair with Dennis Assanis, Mechanical Engineering, August 2010)
 2. Mr. Janardhan Kodavasal (co-chair with Dennis Assanis, Mechanical Engineering, May 2010)

3. Mr. Elliott Ortiz-Soto (co-chair with Dennis Assanis, Mechanical Engineering, May 2010)
 4. Mr. Sotiris Mamalis (co-chair with Dennis Assanis, Mechanical Engineering, December 2009)
 5. Mr. Anastasios Amoratis (co-chair with Dennis Assanis, Mechanical Engineering, June 2009)
 6. Mr. Prasad Challa (co-chair with Dennis Assanis, Mechanical Engineering, December 2008)
- **ME590 Students Supervised**
 1. Mr. Chang-Ping Lee (Winter term, 2009)
 2. Mr. Sourabh Goel (Winter term, 2009)
 - **UROP Students Supervised**
 1. Mr. Joshua Busuito (2 credits/term, September 2009 – April 2010)
 2. Ms. Christine Siew (3 credits/term, September 2006 – April 2007)
 - **Courses**
 1. ME 538: Advanced Internal Combustion Engines, Winter semester 2009 (Three lectures. Also prepared the three homework sets for the class and advised student teams on their class projects).

Research

- **Grants and Contracts:**
 1. “Advanced Combustion Controls – Enabling Systems and Solutions (ACCESS) for High Efficiency Light Duty Vehicles,” funded by the Department of Energy, National Energy Technology Laboratory, 9/30/2010 – 9/29/2014, total funding ~\$25,000,000 including 50% cost share, CO-PI (PI: Hakan Yilmaz, Robert Bosch LCC).
 2. “A University Consortium on Efficient and Clean High Pressure Lean Burn (HPLB) Engines,” funded by the Department of Energy, Office for Energy Efficiency and Renewable Energy, 9/1/2009 – 12/31/2012, total funding \$3,750,000, CO-PI (PI: Dennis Assanis).
 3. “Development of a High Fidelity Vehicle Energy Assessment Simulation and Implementation in the GT-Drive Framework,” funded by the TARDEC FED/CASSI Team, 9/1/2009 – 12/31/2010, total funding \$525,000, CO-PI with a share of approximately \$50,000 (PI: Dennis Assanis).
 4. “Thrust Area 4: JP-8 Engine Combustion Modeling,” plus-up project funded by the Department of Defense (U.S. Army) through the Automotive Research Center, 1/1/2009 – 12/31/2009, \$100,000, PI.
 5. General Motors-University of Michigan Engine Systems Research Collaborative Research Lab (GM/UM ESR CRL), Phase 3, funded by General Motors

Corporation, 1/1/2009 to 12/31/2013, total funding \$3,750,000, CO-PI with a share of approximately \$450,000 (PI: Dennis Assanis).

5. "Modeling and Experimental Study of the Boosted HCCI Engine," funded by General Motors Corporation, 7/1/2007 – 12/31/2009, total funding \$1,365,000, CO-PI with a share of approximately \$350,000 (PI: Dennis Assanis).
6. "Simulation-Based and Experimental Assessment of Variable Valve Timing Strategies for HCCI Engines," funded by Borg Warner, 1/1/2007 – 12/31/2009, total funding \$300,000, CO-PI (PI: Dennis Assanis).
7. "University Consortium on Low Temperature Combustion for High-Efficiency, Ultra-Low Emission Engines," funded by the Department of Energy, 1/1/2006 – 12/31/08, total funding \$4,697,000, CO-PI (PI: Dennis Assanis).
8. "Numerical Assessment of a Free Piston Linear Alternator for Series HEV (Hybrid Electric Vehicle)," funded by General Motors Corporation, 6/1/2005 – 5/31/07, total funding \$525,000, CO-PI (PI: Dennis Assanis).

- **Publications:**

- Articles in Journals and Transactions

1. Ortiz-Soto, E., Assanis, D.N. and Babajimopoulos, A. (2010) A Comprehensive Engine to Drive-Cycle Modeling Framework for the Evaluation of Future Engine and Combustion Technologies. Submitted to *International Journal of Engine Research*.
2. Keum, S., Park, H., Babajimopoulos, A., Assanis, D.N. and Jung, D. (2010) Modeling of Heat Transfer in Internal Combustion Engines with Variable Density Effect. Submitted to *International Journal of Engine Research*.
3. Martz, J.B., Middleton, R.J., Lavoie, G.A., Babajimopoulos, A. and Assanis, D.N. (2010) A Computational Study and Correlation of Premixed Isooctane-Air Laminar Reaction Front Properties under Spark Ignited and Spark Assisted Compression Ignition Engine Conditions. Accepted for publication in *Combustion and Flame*.
4. Mamalis, S., Nair, V., Andruskiewicz, P., Assanis, D. and Babajimopoulos, A. (UM); Wermuth, N. and Najt, P. (GM) (2010) Comparison of Different Boosting Strategies for Homogeneous Charge Compression Ignition Engines – A Modeling Study. *SAE International Journal of Engines*, vol. 3, no. 1, pp. 296-308 (Presented as SAE Paper 2010-01-0571 at the SAE World Congress, Apr 13-15, 2010, Detroit, MI).
5. Babajimopoulos, A., Challa, P., Lavoie, G.A. and Assanis, D.N. (2010) Model-based assessment of two variable cam timing strategies for HCCI engines: Recompression vs. rebreathing. Accepted for publication in the *ASME Journal of Engineering for Gas Turbines and Power* (also presented at the ASME Internal Combustion Engine Division 2009 Spring Technical Conference, May 3-6, 2009, Milwaukee, WI, as ASME Paper ICES2009-76103).

6. Babajimopoulos, A., Lavoie, G.A., Assanis, D.N. (2007) On the role of top dead center conditions in the combustion phasing of homogeneous charge compression ignition engines. *Combustion Science and Technology*, vol. 179, no. 9, pp. 2039-2063.
 7. Chang, K., Babajimopoulos, A., Lavoie, G.A., Filipi, Z.S., Assanis, D.N. (2006) Analysis of load and speed transitions in an HCCI engine using 1-D cycle simulation and thermal networks. *2006 SAE Transactions, Journal of Engines*, vol. 115, no. 3, pp. 621-633 (Presented as SAE Paper 2006-01-1087 at the SAE World Congress, Apr 3-7, 2006, Detroit, MI).
 8. Babajimopoulos, A., Assanis, D.N., Flowers, D.L., Aceves, S.M., Hessel, R.P. (2005) A fully coupled computational fluid dynamics and multi-zone model with detailed chemical kinetics for the simulation of premixed charge compression ignition engines. *International Journal of Engine Research*, vol. 6, no. 5, pp. 497-512.
 9. Aceves, S.M., Flowers, D.L., Espinosa-Loza, F., Babajimopoulos, A., Assanis, D.N. (2005) Analysis of premixed charge compression ignition combustion with a sequential fluid mechanics-multizone chemical kinetics model. *2005 SAE Transactions, Journal of Engines*, vol. 114, no. 3, pp. 252-262 (Presented as SAE Paper 2005-01-0115 at the SAE World Congress, Apr 11-14, 2005, Detroit, MI).
 10. Sjöberg, M., Dec, J.E., Babajimopoulos, A., Assanis, D.N. (2004) Comparing enhanced natural thermal stratification against retarded combustion phasing for smoothing of HCCI heat-release rates. *2004 SAE Transactions, Journal of Engines*, vol. 113, no. 3, pp. 1557-1575 (Presented as SAE Paper 2004-01-2994 at the Powertrain and Fluid Systems Conference and Exhibition, Oct 25-28, 2004, Tampa, FL).
 11. Babajimopoulos, A., Assanis, D.N., Fiveland, S.B. (2002) Modeling the effects of gas exchange processes on HCCI combustion and an evaluation of potential control through variable valve actuation. *2002 SAE Transactions, Journal of Fuels and Lubricants*, vol. 111, no. 4, pp. 1794-1809 (Presented as SAE Paper 2002-01-2829 at the Powertrain and Fluid Systems Conference and Exhibition, Oct 21-24, 2002, San Diego, CA; also included in *Homogeneous Charge Compression Ignition (HCCI) Engines – Key Research and Development Issues*, SAE PT-94, 2003).
- Articles in Refereed Conference Proceedings
1. Manofsky, L., Vavra, J., Babajimopoulos, A. and Assanis, D. (2010) Bridging the Gap between HCCI and SI: Spark-Assisted Compression Ignition. Submitted to the 2011 SAE World Congress.
 2. Delorme, A., Rousseau, A., Wallner, T., Ortiz-Soto, E., Babajimopoulos, A. and Assanis, D. (2010) Evaluation of Homogeneous Charge Compression Ignition (HCCI) Engine Fuel Savings for Various Electric Drive Powertrains. To be presented at the 25th World Battery, Hybrid and Fuel Cell Electric Vehicle Symposium & Exhibition, Nov 5-9, 2010, Shenzhen, China.

3. Shingne, P., Assanis, D. and Babajimopoulos, A. (UM); Keller, P., Roth, D. and Becker, M. (2010) Turbocharger Matching for a 4-Cylinder Gasoline HCCI Engine Using a 1D Engine Simulation. SAE Paper 2010-01-2143, Presented at the SAE Powertrains, Fuels and Lubricants Meeting, Oct 25-27, 2010, San Diego, CA.
4. Mamalis, S. and Babajimopoulos, A. (2010) Model-Based Estimation of Turbocharger Requirements for Boosting an HCCI Engine. ASME Paper ICEF2010-35122. Proceedings of the ASME Internal Combustion Engine Division 2010 Fall Technical Conference, Sep 12-15, San Antonio, TX.
5. Lee, C.-P., Goel, S., and Babajimopoulos, A. (2010) The Effects of Stroke-to-Bore Ratio on HCCI Combustion. SAE Paper 2010-01-0842, Presented at the SAE World Congress, Apr 13-15, 2010, Detroit, MI.
6. Hessel, R., Foster, D., Aceves, S., Davisson, M., Espinosa-Loza, F., Flowers, D., Pitz, W., Dec, J., Sjöberg, M. and Babajimopoulos, A. (2008) Modeling iso-octane HCCI using CFD with multi-zone detailed chemistry; Comparison to detailed speciation data over a range of lean equivalence ratios. SAE Paper 2008-01-0047, Presented at the SAE World Congress, Apr 14-17, 2008, Detroit, MI.
7. Murotani, T., Hattori, K., Sato, E., Chryssakis, C., Babajimopoulos, A. and Assanis, D.N. (2007) Simultaneous reduction of NO_x and soot in a heavy-duty diesel engine by instantaneous mixing of fuel and water. SAE Paper 2007-01-0125, Presented at the SAE World Congress, Apr 16-19, 2007, Detroit, MI.
8. Chang, K., Lavoie, G.A., Babajimopoulos, A., Filipi, Z.S. and Assanis, D.N. (2007) Control of a multi-cylinder HCCI engine during transient operation by modulating residual gas fraction to compensate for wall temperature effects. SAE Paper 2007-01-0204, Presented at the SAE World Congress, Apr 16-19, 2007, Detroit, MI.
9. Aceves, S.M., Flowers, D.L., Chen, J.-Y., Babajimopoulos, A. (2006) Fast prediction of HCCI combustion with an artificial neural network linked to a fluid mechanics code. SAE Paper 2006-01-3298, Presented at the Powertrain and Fluid Systems Conference and Exhibition, Oct 16-19, 2006, Toronto, Canada.
10. Flowers, D., Aceves, S., Babajimopoulos, A. (2006) Effect of charge non-uniformity on heat release and emissions in PCCI engine combustion. SAE Paper 2006-01-1363, Presented at the SAE World Congress, Apr 3-7, 2006, Detroit, MI.
11. Babajimopoulos, A., Lavoie, G.A. and Assanis, D.N. (2003) Modeling HCCI combustion with high levels of residual gas fraction - A comparison of two VVA strategies. SAE Paper 2003-01-3220, Presented at the Powertrain and Fluid Systems Conference and Exhibition, Oct 27-30, 2003, Pittsburgh, PA.
12. Babajimopoulos, A., Lavoie, G.A. and Assanis, D.N. (2003) Numerical modeling of the effects of temperature and composition stratification on HCCI combustion for high levels of residual gas fraction. *Proceedings of the 6th International Conference on Engines for Automobile*, Sep 14-19, 2003, Capri, Italy.

- Patents
 1. Assanis, D.N., Babajimopoulos, A., Filipi, Z.S., Kuo, T.-W., Lavoie, G.A., Najt, P.M., and Rask, R.B. (2009) Hybrid Powertrain System Using Free Piston Linear Alternator Engines. Patent application filed to the U.S. Patent Office, US Serial No. 12/504502, filed 16-JUL-2009.
- Book Chapters
 1. Aceves, S.M, Flowers, D.L., Dibble, R.W. and Babajimopoulos, A. (2007) Overview of modeling techniques and their application to HCCI/CAI engines. In Zhao, H. (Ed.) *HCCI and CAI engines for the automotive industry*, Chap. 18, pp. 456-474, Woodhead Publishing Limited, Cambridge, England.
- Articles in Non-Refereed Conference Proceedings
 1. Hessel, R., Foster, D., Aceves, S., Flowers, D, Pitz, B., Dec, J., Sjöberg, M. and Babajimopoulos, A. (2007) Modeling HCCI using CFD and detailed chemistry with experimental validation and a focus on CO emissions. *Proceedings of the 17th International Multidimensional Engine Modeling User's Group Meeting*, Apr 15, 2007, Detroit, MI.
 2. Babajimopoulos, A., Assanis, D.N., Flowers, D.L., Aceves, S.M., Hessel, R.P. (2005) A fully integrated CFD and multi-zone model with detailed chemical kinetics for the simulation of PCCI engines. *Proceedings of the 15th International Multidimensional Engine Modeling User's Group Meeting*, Apr 10, 2005, Detroit, MI.
- Presentations in Conferences without Proceedings
 1. Babajimopoulos, A., Manofsky, L., Shingne, P., Spater, J., Lavoie, G., and Assanis, D. (2009) UM FFVA Engine: Experimental Recompression Results and GT-Power Modeling. *HCCI University Working Group Meeting at USCAR*, October 8, 2009, Southfield, MI.
 2. Assanis, D.N., Lavoie, G., and Babajimopoulos, A. (2009) Advanced Combustion for High Efficiency Ultra-Clean Engines. Keynote Lecture, 6th US National Combustion Meeting, May 17-20, 2009, Ann Arbor, MI.
 3. Babajimopoulos, A., Nair, V., Lavoie, G. and Assanis, D. (2009) Exploring supercharged HCCI using GT-Power based simulation tool. *HCCI University Working Group Meeting at Sandia National Laboratories*, February 12, 2009, Livermore, CA.
 4. Babajimopoulos, A., Challa, P., Mamalis, S., Lavoie, G., Filipi, Z. and Assanis, D. (2008) System modeling of turbocharging for HCCI. *HCCI University Working Group Meeting at USCAR*, August 21, 2008, Southfield, MI.
 5. Babajimopoulos, A., Lavoie, G., Filipi, Z., Challa, P., Mamalis, S. and Assanis, D. (2008) System modeling of valve actuation strategies and turbocharging for HCCI. *HCCI University Working Group Meeting at Sandia National Laboratories*, March 20, 2008, Livermore, CA.

6. Babajimopoulos, A., Lavoie, G., Filipi, Z., Challa, P., and Assanis, D. (2007) System modeling of valve actuation strategies for HCCI with a realistic combustion model. *HCCI University Working Group Meeting at USCAR*, October 4, 2007, Southfield, MI.
7. Babajimopoulos, A., Lavoie, G., Filipi, Z., Mo, Y., Chang, K. and Assanis, D. (2007) A CFD-based HCCI combustion correlation for use in system models. *HCCI University Working Group Meeting at Sandia National Laboratories*, February 8, 2007, Livermore, CA.
8. Babajimopoulos, A., Lavoie, G.A., Assanis, D.N. (2006) On the role of top dead center conditions in the combustion phasing of homogeneous charge compression ignition engines. Oral only presentation at the Powertrain and Fluid Systems Conference and Exhibition, October 16-19, 2006, Toronto, Canada.
9. Chang, K., Lavoie, G., Babajimopoulos, A., Filipi, Z., and Assanis, D. (2006) Simulation of a multi-cylinder HCCI engine during transient operation by modulating RGF – Compensating for the wall temperature effects. *HCCI University Working Group Meeting at USCAR*, June 29, 2006, Southfield, MI.
10. Babajimopoulos, A., Lavoie, G., Filipi, Z., Im, H., Mo, Y., Chang, K., Hamosfakidis, V. and Assanis, D. (2006) HCCI modeling: System modeling of coolant temperature effect and update on CFD results. *HCCI University Working Group Meeting at Sandia National Laboratories*, February 9, 2006, Livermore, CA.
11. Babajimopoulos, A., Lavoie, G. and Assanis, D. (2005) Scaling of HCCI combustion phasing: The role of TDC conditions. *HCCI University Working Group Meeting at USCAR*, September 15, 2005, Southfield, MI.
12. Babajimopoulos, A., Lavoie, G., Filipi, Z., Mo, Y., Chang, K. and Assanis, D. (2005) Recent HCCI modeling results and application to system models. *HCCI University Working Group Meeting at Sandia National Laboratories*, February 3, 2005, Livermore, CA.
13. Assanis, D., Filipi, Z., Lavoie, G., Babajimopoulos, A., Chang, K. and Mo, Y. (2004) Modeling HCCI for control and system simulation. *HCCI University Working Group Meeting at USCAR*, June 24, 2004, Southfield, MI.
14. Babajimopoulos, A., Lavoie, G., Mo, Y. and Assanis, D. (2004) Developments in HCCI modeling at the University of Michigan. *HCCI University Working Group Meeting at Sandia National Laboratories*, January 29, 2004, Livermore, CA.
15. Assanis, D., Filipi, Z., Lavoie, G., Babajimopoulos, A. and Chang, J. (2003) Progress in HCCI thermo-kinetic Modeling and engine experiments. *HCCI University Working Group Meeting at USCAR*, June 26, 2003, Southfield, MI.
16. Babajimopoulos, A., Assanis, D. and Fiveland, S. (2002) Sequential use of an open cycle CFD code and a multi-zone model for assessment of VVA control strategies. *HCCI University Working Group Meeting at USCAR*, June 12, 2002, Southfield, MI.

- Invited Seminars

1. Babajimopoulos, A. (2008) An introduction to Homogeneous Charge Compression Ignition (HCCI). Dept. of Naval Engineering, National Technical University of Athens, September 22, 2008, Athens, Greece.
2. Babajimopoulos, A. (2008) An introduction to Homogeneous Charge Compression Ignition (HCCI) and the ongoing work at the University of Michigan. Graduate Seminar Series, Dept. of Mechanical Engineering, Marquette University, April 10, 2008, Milwaukee, WI.

Service

- Co-organizer for the Kinetically Controlled CI Combustion (including HCCI) session, SAE 2011 World Congress, April 12-14, 2011, Detroit, MI
- Co-organizer for the Kinetically Controlled CI Combustion (HCCI) session, SAE 2010 World Congress, April 13-15, 2010, Detroit, MI
- Review coordinator for the Low Temperature Combustion session, ASME Internal Combustion Engine Division 2009 Fall Technical Conference, September 27-30, 2009, Lucerne, Switzerland
- Co-organizer for the Homogeneous Charge Compression Ignition session, SAE 2009 International Powertrains, Fuels and Lubricants Meeting, June 15-17, 2009, Florence, Italy
- Co-chair for the Multi-dimensional Modeling session, ASME Internal Combustion Engine Division 2009 Spring Technical Conference, May 3-6, 2009, Milwaukee, WI
- Co-organizer for the Homogeneous Charge Compression Ignition session, SAE 2009 World Congress, April 20-23, 2009, Detroit, MI
- Judge, UM Engineering Graduate Student Symposium, November, 2006
- Reviewer for
 1. SAE/JSAE
 2. ASME/IMECE
 3. The Combustion Institute
 4. Transactions of the ASME – Journal of Engineering for Gas Turbines and Power
 5. International Journal of Engine Research
 6. Proceedings of the Institution of Mechanical Engineers, Part D, Journal of Automobile Engineering
 7. IEEE/ASME Transactions on Mechatronics
 8. Combustion and Flame
 9. Journal of Energy Resources Technology

10. Combustion Science and Technology

11. Energy

Brief Biography

Daniel Flowers is the Associate Program Leader for Combustion and Alternative Fuels at Lawrence Livermore National Laboratory, where his work focuses on experimental and analytical research in thermal sciences and combustion. He has been working in the area of Homogeneous Charge Compression Ignition (HCCI) engine combustion since joining LLNL in 1998. Flowers leads several combustion research projects at LLNL in the areas of HCCI, hydrogen and Diesel combustion. On leave from LLNL Flowers led research and development at Cleeves Engines, an energy research startup company. Flowers served as Associate Technical Editor of the ASME Journal of Energy Resource Technologies in 2007 and 2008. Flowers holds Ph.D. (2001), M.S. (1997), and B.S. (1996) degrees in Mechanical Engineering from the University of California, Davis.

Work History

Lawrence Livermore National Laboratory, September 1998 to present

Title: Principal Investigator/Project Leader

Responsibilities:

- Principal Investigator – DOE OFCVT Combustion and Fuels Programs (\$1M/FY07)
 - Leading Ongoing LLNL activities in HCCI research, developing multidimensional modeling tools
 - Leading collaborations with Universities and Other National Labs
 - Program highly ranked at annual program review
 - Integral part of a world recognized team that has developed the most advanced analysis tools for HCCI combustion
 - Extending analysis tools for HCCI combustion – Continuing to advance multidimensional HCCI combustion modeling tool
 - Continuing development of massively parallel tool for simulation of multidimensional HCCI and PCCI combustion
 - Collaborating with US auto industry partners to guide development of new combustion systems
 - Investigating HCCI applications for biofuels and non-standard fuels: biodiesel, “wet ethanol,” “trash gas”
- Principal Investigator – DOE NETL (\$300K/FY07)
 - Separate project on HCCI working with International Engine Company funded by NETL
 - Modeling to support International Engine’s HCCI Engine Development program
- Principal Investigator - DOE/OFCVT
 - Modeling of Hydrogen Spark Ignition Combustion (\$150K FY06)
 - Modeling of Smokeless Rich Diesel Combustion (\$150K FY06)
- Principal Investigator/Project Leader – HCCI engines for stationary power generation (California Energy Commission, 3 years \$2M)
 - Leading development of an experimental HCCI engine for stationary power generation applications
 - Completed 2006

Cleeves Engines Incorporated (San Carlos, CA), February 2008 to June 2009

Title: Senior Combustion Engineer

Responsibilities:

- Leading Research and Development activities on an advanced technology concept.
- Concept development advanced operating strategies for an advanced internal combustion engine strategy
- Developing test cell hardware, methods, and protocols for demonstration of engine

- concept
- Guiding and conducting numerical analysis activities for prototype engine development, including CFD (Fluent), Engine dynamic modeling (GT-Power), and FEA (Cosmos, Ansys)
- Cleevs Engines is an Energy Technology startup developing advance internal combustion engine concepts

Education

Ph.D in Mechanical Engineering – University of California, Davis

Dissertation: Combustion in Homogeneous Charge Compression Ignition Engines: Experiments and Detailed Kinetic Modeling

M.S. in Mechanical Engineering - University of California, Davis

Thesis: Application of Morphology Dependent Resonance Spectroscopy to Droplet Sizing

B.S. in Mechanical Engineering – University of California, Davis (Highest Honors)

Professional Activities

Associate Technical Editor, ASME Journal of Energy Resources Technology

The Combustion Institute, Member (Alternate on Executive Committee)

Society of Automotive Engineers, Member

American Society of Mechanical Engineers, Member

Symposium Co-Chair, Advanced Energy Systems, ASME IMECE, 2004

Session Organizer and Chair, Advanced Energy Systems, ASME IMECE, Multiple years

Session Chair, Society of Automotive Engineers, Multiple years

Mentoring and Education

Mentor to LLNL Graduate Research Fellows and LLNL Graduate Student Employees

Long-standing collaboration with Profs. Robert Dibble and J.Y. Chen at UC Berkeley.

Direction and Research Guidance to UC Berkeley Graduate Students.

Mentor and project leader to several LLNL Undergraduate Engineering Interns.

Invited Mini-course, Universidad de Guanajuato, Mexico: Introduction to Kiva3v.

Patent

Daniel L. Flowers, “Controlling and Operating Homogeneous Charge Compression Ignition (HCCI) Engines,” U.S. Patent 6,923,167

Book Chapter

S. M. Aceves, D. L. Flowers, R. W. Dibble and A. Babajimopoulos, “Overview of modeling techniques and their application to HCCI/CAI engines,” in HCCI and CAI engines for the automotive industry, Hua Zhao, Ed., in press.

Peer Reviewed Publications

Journal Papers

Killingsworth, N.J., Aceves, S.M., **Flowers, D.L.**, Espinosa-Loza, F.J., and Kristic, M., "HCCI Engine Combustion Timing Control: Optimizing Gains and Fuel Consumption Via Extremum Seeking," IEEE Transactions on Control Systems Technology, in press (2008).

D.L. Flowers, S.M. Aceves, R.W. Dibble, "Effect of Laser-induced Excitation of Oxygen on Ignition in HCCI Engines Analyzed by Numerical Simulations," *Combustion Theory And Modeling*, Vol. 11, No. 3, 2007: 455-468.

J.H. Mack, B.A. Buchholz, **D.L. Flowers** and R.W. Dibble. "Using Biofuel Tracers to Study Alternative Combustion Regimes," *Nuclear Instruments & Methods B* (2006) in press.

Aristotelis Babajimopoulos, Dennis Assanis, **Daniel Flowers**, Salvador Aceves, Randy Hessel "A Fully Integrated CFD and Multi-zone Model with Detailed Chemical Kinetics for the Simulation of PCCI Engines" *International Journal of Engine Research*, Volume 6, Number 5, October 2005, pp. 497-512(16).

Parag Mehresh, **Daniel Flowers**, Robert Dibble, "Experimental and Numerical Investigation of Effect of Fuel on Ion Sensor Signal to Determine Combustion Timing in HCCI Engines," *International Journal of Engine Research*, Volume 6, Number 5, October 2005, pp. 465-474(10).

Parag Mehresh, Jason Souder, **Daniel Flowers**, Uwe Riedel, Robert Dibble, "Combustion Timing in HCCI Engines Determined by Ion-Sensor: Experimental and Kinetic Modeling," *Proceedings of the Combustion Institute*, Vol 30, Part 2, 2005: 2693-2700.

Hunter Mack, Bruce Bucholtz, **Daniel Flowers**, Robert Dibble, "Investigation of HCCI Combustion of Diethyl Ether and Ethanol Mixtures Using Carbon 14 Tracing and Numerical Simulations," *Proceedings of the Combustion Institute*, Vol 30, Part 2, 2005: 2701-2709.

Martinez-Frias J, Aceves SM, **Flowers D**, Smith JR, Dibble R, "Thermal charge conditioning for optimal HCCI engine operation" *ASME* Vol. 124 No. 1, March 2002: 67-75.

Flowers, D. L., Aceves, S.M., Martinez-Frias, J., and Dibble, R. W., "Prediction of Carbon Monoxide and Hydrocarbon Emissions in Isooctane HCCI Engine Combustion Using Multi-Zone Simulations," *Proceedings of the Combustion Institute*, Vol 29, Part 1, 2002: 687-694.

Flowers, D. L., Aceves, S. M., Westbrook, C. K., Smith, J. R., Dibble, R. W., "Detailed Chemical Kinetics Simulation of HCCI Combustion Gas Composition Effects and Investigation of Control Strategies," *ASME Journal of Engineering for Gas Turbines and Power*, Vol. 123, No. 2, April 2001.

Santangelo, P. J., **Flowers, D. L.**, and Kennedy, I. M., "Demonstration of droplet size and vaporization rate measurements in the near field of a two-phase jet with droplet lasing spectroscopy," *Applied Optics*, 1998 Aug 20, Vol 37 No. 24: 5573-5578.

SAE Transactions Papers

Hessel, R.P, Aceves, S.M., **Flowers, D.L.**, "A Comparison on the Effect of Combustion Chamber Surface Area and In-Cylinder Turbulence on the Evolution of Gas Temperature Distribution from IVC to SOC: A Numerical and Fundamental Study," *SAE Paper 2006-01-0869 SAE Transactions, Journal of Engines*, 2006.

Aceves, S.M., **Flowers, D.L.**, "A Detailed Chemical Kinetic Analysis of Low-Temperature, Non-Sooting Diesel Combustion," SAE Paper 2005-01-0923, SAE Transactions, Journal of Engines, 2005.

Aceves, S.M., **Flowers, D. L.**, Espinosa-Loza, F.J., Babajimopoulos, A., Assanis, D., "Analysis of Premixed Charge Compression Ignition Combustion With a Sequential Fluid Mechanics-Multizone Chemical Kinetics Model," SAE Paper 2005-01-0115, SAE Transactions, Journal of Engines, 2005.

Salvador Aceves, **Daniel Flowers**, "Analysis of the Effect of Geometry Generated Turbulence on HCCI Combustion by Multi-Zone Modeling" SAE Paper 2005-01-2134, SAE Transactions, Journal of Engines, 2005.

Parag Mehresh, **Daniel Flowers**, Robert Dibble, "EGR effect on Ion Signal in HCCI Engines," SAE Paper 2005-01-2126, SAE Transactions, Journal of Engine, 2005.

Hunter Mack, Bruce Bucholtz, **Daniel Flowers**, Robert Dibble, "Effect of the Di-Tertiary Butyl Peroxide (DTBP) additive on HCCI Combustion of Fuel Blends of Ethanol and Diethyl Ether" SAE Paper 2005-01-2135, SAE Transactions, Journal of Fuels and Lubricants, 2005.

Salvador M. Aceves, **Daniel L. Flowers**, Francisco Espinosa-Loza, Joel Martinez-Frias, John E. Dec, Magnus Sjöberg, Robert W. Dibble and Randy P. Hessel, "Spatial Analysis of Emissions Sources for HCCI Combustion at Low Loads Using a Multi-Zone Model," SAE Paper 2004-01-1910, SAE Transactions, Journal of Fuels and Lubricants, 2004.

Daniel L. Flowers, Salvador M. Aceves, Joel Martinez-Frias, Randy Hessel, and Robert W. Dibble, "Effects of Mixing on Hydrocarbon and Carbon Monoxide Emissions, Predictions for Isooctane HCCI Engine Combustion Using a Multi-Zone Detailed Kinetics Solver," SAE Paper 2003-01-1821, SAE Transactions, Journal of Fuels and Lubricants, 2003.

Salvador M. Aceves, **Daniel L. Flowers**, Francisco Espinosa-Loza, Joel Martinez-Frias, Robert W. Dibble, Magnus Christensen, Bengt Johansson, Randy P. Hessel, "Piston-Liner Crevice Geometry Effect on HCCI Combustion by Multi-Zone Analysis," SAE Paper 2002-01-2869, SAE Transactions, Journal of Engines, Volume 111, pp. 2691-2698, 2002.

Aceves, S.M., Martinez-Frias, J., **Flowers, D. L.**, Smith, J. R., Dibble, R. W., "A Decoupled Model of Detailed Fluid Mechanics Followed By Detailed Chemical Kinetics for Prediction of Iso-Octane Hcci Combustion," SAE Paper 2001-01-3612, SAE Transactions, Journal of Fuels and Lubricants, 2001.

Aceves, S. M., **Flowers, D. L.**, Martinez-Frias, J., Smith, J. R., Westbrook, C. K., Pitz, W. J., Dibble, R. W. "Multi-Zone Analysis of Propane HCCI Combustion," SAE Paper 2001-01-1027, SAE Transactions, Journal of Engines, 2001.

Martinez-Frias, J. M., Aceves, S. M., **Flowers, D. L.**, Smith, J. R., Dibble, R. W., "HCCI Engine Control by Thermal Management," SAE Paper 2000-01-2869, SAE Transactions, Journal of Engines, 2000.

Aceves, S.M, **Flowers, D. L.**, Westbrook, C. K., Smith, J. R., Pitz,W., Dibble, R. W., Christensen, M., and Johansson, B., 2000, "A Multi-Zone Model for Prediction of HCCI Combustion and Emissions," SAE paper 2000-01-0327, SAE Transactions, Journal of Engines, 2000.

Other SAE Papers

Hessel, R.P., Foster, D., Steeper, R., Aceves, S.M., **Flowers, D.L.**, "Pathline Analysis of Full-cycle Four-stroke HCCI Engine Combustion Using CFD and Multi-Zone Modeling," SAE Paper 2008-01-0048.

Hessel, R., Babajimopoulos, A., Foster, D., Aceves, S., Davisson, M, Espinosa-Loza, F.J., Flowers, D.L., Pitz, W., Dec, J., Sjoberg, M., " Modeling Iso-octane HCCI using CFD with Multi-Zone Detailed Chemistry; Comparison to Detailed Speciation Data over a Range of Lean Equivalence Ratios, 2008-01-0047.

Flowers, D.L., Aceves, S.M, Martinez-Frias, J., "Improving Ethanol Life Cycle Energy Efficiency by Direct Utilization of Wet Ethanol in HCCI Engines," SAE Paper 2007-01-1867/JSAE Paper 20077037.

S.M. Aceves, **D.L.Flowers**, J.Y. Chen, A. Babajimopoulos, "Fast Prediction of HCCI Combustion With an Artificial Neural Network Linked to a Fluid Mechanics," SAE Paper 2006-01-3298.

R.P. Hessel, N. Abani, S. Aceves, **D. Flowers**, "Gaseous Fuel Injection Modelling Using a Gaseous Sphere Injection Methodology," SAE Paper 2006-01-3265.

Flowers, D.L., Aceves, S.M., Babajimopoulos, A., "Effect of Charge Non-uniformity on Heat Release and Emissions in PCCI Engine Combustion," SAE Paper 2006-01-1363.

Salvador M. Aceves, **Daniel Flowers**, Joel Martinez-Frias, Francisco Espinosa-Loza, William J. Pitz, Robert Dibble, "Fuel and Additive Characterization for HCCI Combustion," SAE paper 2003-01-1814.

Salvador M. Aceves, Joel Martinez-Frias, **Daniel Flowers**, J. Ray Smith, Robert Dibble, J.Y. Chen, "A Computer Generated Reduced Iso-Octane Chemical Kinetic Mechanism Applied to Simulation of HCCI Combustion," SAE Paper 2002-01-2870.

James W. Girard, Robert W. Dibble, **Daniel L. Flowers**, Salvador M. Aceves, "An Investigation of the Effect of Fuel-Air Mixedness on the Emissions from an HCCI Engine," SAE Paper 2002-01-1758.

Martinez-Frias, J., Aceves, S.M., **Flowers, D. L.**, Smith, J. R., Dibble, R. W., "Equivalence Ratio-Egr Control of Hcci Engine Operation and the Potential for Transition to Spark-Ignited Operation, " SAE Paper 2001-01-3613.

Flowers, D. L., Aceves, S. M., Martinez-Frias,J., Smith, J. R., Au, M. Y., Girard, J. W., Dibble, R. W., 2001, "Operation of a Four-Cylinder 1.9 L Propane Fueled Homogeneous Charge Compression Ignition Engine," SAE Paper 2001-01-1895.

Au, M., Girard, J. W., Dibble, R. W., Seibel, C., Maas, U., Aceves, S. M., **Flowers, D. L.**, Martinez-Frias, J., Smith, J. R., 2001, "Four-Cylinder HCCI Engine Operation with Exhaust Gas Recirculation," SAE Paper 2001-01-1894.

Flowers, D. L., Aceves, S. M., Smith, J. R., Torres, J., Girard, J., and Dibble, R. W., "HCCI in a CFR Engine: Experiments and Detailed Kinetic Modeling," SAE paper 2000-01-0328.

Aceves, S. M., Smith, J. R., Perkins, L. J., Haney, S. W., **Flowers, D. L.**, "Optimization of a CNG Series Hybrid Concept Vehicle," SAE paper 960234.

Other Conference Papers

Killingsworth NJ, Aceves SM, **Flowers DL**, Krstic M. "A simple HCCI engine model for control." IEEE Conference on Computer Aided Control System Design, 2006 IEEE International Conference on Control Applications, 2006 IEEE International Symposium on Intelligent Control. IEEE. 2006, pp. 6.

Walther, D.C., Fernandez-Pello, A.C., Dibble, R., Aceves, S.M., **Flowers, D.** "The use of hydrogen combustion for power generation" 3rd International Energy Conversion Engineering Conference, v 3, Collection of Technical Papers - 3rd International Energy Conversion Engineering Conference, 2005, p 1919-1938.

Flowers, Daniel L., Martinez-Frias, Joel, Espinosa-Loza, Francisco, Killingsworth, Nick, Aceves, Salvador M., Dibble, Robert, Kristic, Miroslav, Bining, Avtar, "Development and testing of a 6-cylinder HCCI engine for distributed generation," Proceedings of the 2005 Fall Technical Conference of the ASME Internal Combustion Engine Division, 2005, p 643-651.

Martinez-Frias, Joel, **Flowers, Daniel**, Aceves, Salvador M., Espinosa-Loza, Francisco, Dibble, Robert, "Thermal management for 6-cylinder HCCI engine: Low cost, high efficiency, ultra-low NOx power generation," Proceedings of the 2004 Fall Technical Conference of the ASME Internal Combustion Engine Division, 2004, p 833-839.

Martinez-Frias, Joel, Aceves, Salvador M., **Flowers, Daniel**, Smith, J. Ray, Dibble, Robert, "Exhaust energy recovery for control of a homogeneous charge compression ignition engine," American Society of Mechanical Engineers, Advanced Energy Systems Division (Publication) AES, v 40, 2000, p 349-356.

Santangelo, P.J. (Univ of California Davis); **Flowers, D.**; Kennedy, I.M. "Measurements of droplet size in the near field of a droplet laden jet using MDR spectroscopy," Chemical and Physical Processes in Combustion, Fall Technical Meeting, The Eastern States Section, 1997, p 265.

Thesis and Dissertation

Flowers, D. L., "Combustion in Homogeneous Charge Compression Ignition Engines: Experiments and Detailed Chemical Kinetic Simulations" Ph.D. Dissertation, University of California, Davis, 2001

Flowers, D. L., "Application of Morphology Dependent Resonance Spectroscopy to Droplet Sizing" Masters Thesis, University of California, Davis, 1997.

CURRICULUM VITAE
SHAWN W. MIDLAM-MOHLER, PH.D.
3938 Norbrook Dr.
Columbus, Ohio 43220
(614) 307-4176
midlam-mohler.1@osu.edu

EDUCATION

Engineering Education

Ph.D.	Mechanical Engineering The Ohio State University Dissertation Title: "Modeling, Control, and Diagnosis of a Diesel Lean NO _x Trap Catalyst"	Columbus, OH	6/2005
M.S.	Mechanical Engineering The Ohio State University Thesis Title: "A Novel Fuel-Operated Heater for Automotive Thermal Management"	Columbus, OH	3/2001
B.S.	Mechanical Engineering Wright State University Senior Design Project: "Aerodynamic Design and Simulation of a Wind-Turbine"	<i>Summa cum Laude</i> Dayton, OH	6/1999

Academic Fellowships

- Graduate Automotive Technology Education Program – Ph.D. Studies Source: Dept. of Energy
- Awarded to select graduate students conducting research supporting DOE goals for transportation research
- University Fellowship – M.S. Studies Source: Ohio State University
- Awarded in a university-wide search to attract high-caliber graduate students

**RESEARCH
EXPERIENCE**

Research Appointments

- Research Scientist** 10/2008 to present
Ohio State University Center for Automotive Research, Columbus, OH
- Conduct research in the area of clean and efficient transportation, including emissions reduction, Diesel engines, alternative combustion, hydrogen generation, heavy fuel atomization, and advanced powertrains
 - Directed and advised graduate students in this area of research
- Senior Research Associate** 11/2005 to 9/2008
Ohio State University Center for Automotive Research, Columbus, OH
- Conducted research in the area of clean and efficient transportation
 - Directed and advised graduate students in this area of research
- Research Associate II** 2/2004 to 10/2005
Ohio State University Center for Automotive Research, Columbus,
- Conducted research in the area of clean and efficient transportation

Research Intern

6/2003 to 9/2003

Ford Scientific Research Labs, Dearborn, MI

- Conducted research on emissions reductions for gasoline hybrid-electric vehicles
- Three-month assignment resulted in three Ford invention disclosures and two U.S. patents

Research Funding

As a PI or co-PI, Dr. Midlam-Mohler has averaged over a half million dollars in research per year since 2005. These projects are identified in the following sections.

Projects as PI / Co-PI:

\$50,000/1 years	Title: Analysis of Secondary Powertrain Systems in HEVs Source: CAR Industrial Consortium	Start: 10/2009 Role: PI
\$40,000/0.5 years	Title: Life Cycle Analysis of Landfill Derived Natural Gas Source: FirmGreen	Start: 4/2009 Role: PI
\$99,000/2 year	Title: Fleet Studies of Plug-In Electric Hybrid Vehicles Source: SMART@CAR Consortium	Start: 1/2009 Role: PI
\$2,000,000/3 years ¹	Title: EcoCAR Challenge Hybrid Electric Vehicle Project Source: US Department of Energy and numerous other sponsors	Start: 6/2008 Role: Co-PI
\$943,108/4 years	Title: Coordinated Diesel Engine and Aftertreatment Control Source: Cummins	Start: 4/2008 Role: PI
\$724,531/3 years	Title: Hierarchical Approach to Engine Modeling Source: General Motors	Start: 4/2007 Role: Co-PI
\$234,760/2 years	Title: Soot Filter Regeneration through External Heat Addition Source: Tenneco Automotive	Start: 11/2005 Role: Co-PI
\$673,550/3 years	Title: On-Board Fuel Reformation for Diesel Aftertreatment Source: Tenneco Automotive	Start: 11/2005 Role: Co-PI

Minor Projects as PI/co-PI:

\$45,000	Miscellaneous small projects Source: Hi-Stat, Henkel	2009
\$22,500	Miscellaneous small projects Source: National Energy Technology Lab, Nextech Materials	2008

Projects with Major Research Role (not co-PI):

\$940,863/4 years	Title: Next Generation Charge Estimation for IC Engines Source: General Motors	Start: 7/2004 Role: Researcher
\$1,327,954/5 years	Title: Next Generation AFR Control for IC Engines Source: General Motors	Start: 7/2004 Role: Researcher

¹ This is the estimated cost of the research conducted under this problem if funded from an external sponsor. This project is heavily leveraged by the Department of Energy, General Motors, Ohio State University, and a number of other sponsors through in-kind contributions as well as direct funding and fellowships.

Instructional Appointments

Adjunct Assistant Professor

7/2009 to present

Ohio State University Department of Mechanical Engineering, Columbus, OH

- Granted in recognition of significant educational service to the Mechanical Engineering Department
- Service includes one-on-one student advising, student project advising, and supervision of undergraduate research

Instructor

4/2007 to present

Ohio State University Department of Mechanical Engineering, Columbus, OH

- Sole instructor of record for two applied thermal and fluids courses on internal combustion engines

Course Development

ME 631 - Powertrain Laboratory (3 CR)

1/2009

Ohio State University Department of Mechanical Engineering, Columbus, OH

- Developed course material for two quarter hours of classroom lecture which reinforced lab work
- Developed eight new lab experiments based on in-depth knowledge of the automotive industry
- Facilitated donation of a gasoline engine from General Motors and a Diesel engine from Cummins, both with a calibration system to provide students access to cutting-edge equipment

ME 730 - Internal Combustion Engine Modeling (3 CR)

4/2007

Ohio State University Department of Mechanical Engineering, Columbus, OH

- Developed all new lecture material to bring in personnel research experience
- Developed new homework assignments to better engage students by building a fully functioning engine model in stages of greater fidelity and complexity
- Facilitated the donation of industry-standard engine simulation software for use by students
- Developed capstone project which allowed students to become engaged in a topic of interest

Seminar - Alternative Fuels Short Course

1/2007

Ohio State University Center for Automotive Research Distance Education Program

- Developed 10 hours of lecture and lecture notes for industrial distance education program
- Provided case studies of alternative-fueled vehicles to reinforce concepts for the industry audience

Teaching Experience

ME 631 – Powertrain Laboratory (3 CR)

Sole Instructor of Record

1/2010

Overall Teaching Rating: 5.0/5.0

Class Size: 15

ME 730 - Internal Combustion Engine Modeling (3 CR)

Sole Instructor of Record

4/2009

Overall Teaching Rating: 4.4/5.0

Class Size: 7

ME 631 – Powertrain Laboratory (3 CR)

Sole Instructor of Record

1/2009

Overall Teaching Rating: 4.8/5.0

Class Size: 12

ME 730 - Internal Combustion Engine Modeling (3 CR)

Sole Instructor of Record

4/2007

Overall Teaching Rating: 4.5/5.0

Class Size: 8

Academic Advising

Since 2005, Dr. Midlam-Mohler has become increasingly involved in student advising. He has served in an advisory or supervisory capacity to the following students at the M.S. and Ph.D. level:

<u>Degree</u>	<u>Student</u>	<u>Role</u>	<u>Graduation Date or Expected Graduation Date</u>
Ph.D.	Quiming Gong	Research Supervisor	2012
Vis. Scholar	Bernhard Grimm	Research Supervisor	2010
M.S.	John Davis	Co-Advisor	2011
Ph.D.	Jason Meyer	Research Supervisor	2011
Honors B.S.	Katherine Bovee	Acting Advisor	2010
Honors B.S.	John Davis	Acting Advisor	2010
Honors B.S.	Ryan Everett	Acting Advisor	2010
Ph.D.	Kenny Follen	Research Supervisor	2010
M.S.	Beth Bezaire	Acting Advisor	2010
M.S.	Brad Cooley	Acting Advisor	2010
M.S.	Chris Hoops	Acting Advisor	2010
M.S.	Ming Fang	Acting Advisor	2009
Honors B.S.	Chris Hoops	Acting Advisor	2009
M.S.	Dave Ortiz	Supervisor	2009
M.S.	Rajaram Maringanti	Acting Advisor	2009
M.S.	Joshua Supplee	Acting Advisor	2009
Vis. Scholar	Adalbert Wolany	Supervisor	2009
Ph.D.	Sai Rajagopalan	Committee Member	2009
Ph.D.	Sergio Hernandez	Acting co-advisor	2008
Vis. Scholar	Andrea Pezzini	Supervisor	2008
Vis. Scholar	Patrick Rebecchi	Supervisor	2008
Honors B.S.	Rhisee Bhatt	Acting co-advisor	2007
Vis. Scholar	Simone Bernasconi	Supervisor	2007
M.S.	Josh Cowgill	Acting co-advisor	2007
M.S.	Kenny Follen	Acting co-advisor	2007
M.S.	Courtney Coburn	Acting Advisor	2006
M.S.	Adam Vosz	Acting Advisor	2006
M.S.	Eric Snyder	Acting co-advisor	2005

Undergraduate Student Research Assistants:

Dr. Midlam-Mohler has supervised the following students on research outside of a formal degree program:

<u>Degree</u>	<u>Student</u>	<u>Role</u>	<u>Year</u>
B.S.	John Macauley	Supervisor	2009-10
B.S.	Alixandra Keil	Supervisor	2009-10
B.S.	Jennifer Loy	Supervisor	2009-10
B.S.	Sean Ewing	Supervisor	2009
B.S.	David Griffin	Supervisor	2009

B.S.	Ross Wang	Supervisor	2009
B.S.	Orlando Inoa	Supervisor	2008-09
B.S.	Al Godfrey	Supervisor	2008-09
B.S.	John Lutz	Supervisor	2008
B.S.	Konrad Svzed	Supervisor	2008
B.S.	Joshua Supplee	Supervisor	2007

Mentor for Local High School Students

Dr. Midlam-Mohler has mentored six local high school students for ~30 hours of activity per student since 2007.

Student Organization Advising

EcoCAR Challenge Hybrid Electric Vehicle Team 6/2008 - present
Ohio State University

- Co-advise 40 member (~80% undergraduate) student design project team competing in U.S. Department of Energy sponsored vehicle competition
- Oversee day-to-day operation of team as they design, build, and test a hybrid electric SUV
- Team won 1st place in first year, 4th place in second year
- Nominated by team for “NSF Advisor of the Year Award”

Challenge-X Hybrid Electric Vehicle Team 8/2006 – 6/2008
Ohio State University

- Co-advise primarily undergraduate team competing in Department of Energy Sponsored advanced technology vehicle completion
- Over the course of the four year competition from 2004 – 2008, OSU placed 3rd, 4th, 4th, and 3rd respectively in the premier advanced technology vehicle competition

Professional Development and Service - Education

Lecturer for Groups Touring the Ohio State Center for Automotive Research 1/2007 - present
Ohio State University Center for Automotive Research

- Provide 30 – 60 minute presentation and discussion on topic of energy use in transportation to groups
- Reached over 500 individuals including elementary school students, college students, and community groups

OSU Continuing Education Program, Columbus, OH 9/2010
Presenter

- Provided one hour seminar to practicing engineers on green vehicle design

Lilly Conference on College Teaching 11/2009
Miami University Teaching Conference

- Attended three day conference on college teaching

Teaching at Ohio State Orientation 9/2009
Ohio State University Faculty Development Workshop

- Attended the following seminars over the course of two and a half days: Introduction to Teaching and Learning; Fair and Efficient Grading; Designing Assignments Quizzes, and Tests; and Seven Habits of Effective Teachers - Universal Design for Learning; and Developing Effective Presentation Skills

OSU Continuing Education Program, Columbus, OH 9/2009
Presenter

- Provided one hour seminar to practicing engineers on green vehicle design

Ohio State Mechanical Engineering Curriculum Development Retreat, Columbus, OH 7/2009

Participant in Design Focus Group

- Requested by Dept. Chair to serve in Design Focus Group
- Participated with faculty colleagues and alumni to evaluate engineering curriculum as OSU

Summer Institute on Course Design 6/2009

Ohio State University Faculty Development Workshop

- Attended 15 hour, hands-on seminar on effective course design
- Learned structured techniques for developing courses
- Defined course goals, learning objectives, course content, and methods of assessment for a course

PROFESSIONAL SERVICE

Professional Service

Clean Fuels Ohio, Columbus, OH 9/2009 to present

Member of the Board of Directors

- Elected to Board of Directors of Clean Fuels Ohio, a non-profit committed to cleaner transportation fuels

State of Indiana 4/2009

Proposal Reviewer

- Reviewed multi-million dollar proposal for Indiana grant program in area of internal combustion engines

Natural Gas Fleet Stakeholders Meeting, Grove City, OH 11/2008

Panel Member

- Served as panel technical expert on alternative vehicular fuels
- Meeting attended by designees' from the Governor's office and from both of Ohio's U.S. Senators' staff

McMaster Fuel Ltd., Perrysburg, OH 9/2006 to 1/2007

Independent Consultant

- Provided analysis of a hydrogen production technique against other methods of hydrogen production
- Provided analysis of these techniques for emissions reduction
- Assisted McMaster Fuel Ltd. in making strategic decisions regarding their technology

Publication Reviewer Continuous

- Review numerous publications for conferences and journal submission of ASME, SAE, IEEE, *etc.*

PUBLICATIONS

Scholarly Publications

Journal Articles:

1. J. Meyer, S. Yurkovich, S. Midlam-Mohler, "An Approach for Cylinder Specific AFR Prediction," *in preparation* for submission to ASME Journal of Dynamic Systems, Measurements, and Controls.
2. S. Midlam-Mohler, R. Maringanti, M. Fang, "Inverse-Distance Interpolation Methods for Diesel Engine Combustion Control," *in preparation* for submission to ASME Journal of Dynamic Systems, Measurements, and Controls.

3. M. Canova, S. Midlam-Mohler, P. Pisu, A. Soliman, "Model-Based Fault Detection and Isolation for a Diesel Lean NOx Trap Aftertreatment System," *Control Engineering Practice*, November 2009.
4. M. Canova, S. Midlam-Mohler, Y. Guezennec, G. Rizzoni, "Mean Value Modeling and Analysis of HCCI Diesel Engines with External Mixture Formation," *ASME Journal of Dynamic Systems, Measurement and Control*, Vol. 131, No. 11, 2009.
5. M. Canova, S. Midlam-Mohler, Y. Guezennec, G. Rizzoni, "Theoretical and Experimental Investigation on Diesel HCCI Combustion with External Mixture Preparation," *International Journal of Vehicle Dynamics*, Volume 44, Nos 1-2, 2007.
6. N. Szabo, C. Lee, J. Trimboli, O. Figueroa, R. Ramamoorthy, S. Midlam-Mohler, A. Soliman, H. Verweij, P. Dutta and S. Akbar, "Ceramic-Based Chemical Sensors, Probes and Field-Tests in Automobile Engines," *Journal of Materials Science*, November, 2003.

Conference Papers:

1. Qi. Gong, S. Midlam-Mohler, V. Marano, G. Rizzoni, Y. Guezennec, "Statistical analysis based PHEV fleet data study", 2010 IEEE Vehicle Power and Propulsion Conference, September, 2010.
2. Kerem Bayar, Beth Bezaire, Brad Cooley, John Kruckenberg, Eric Schact, Shawn Midlam-Mohler, Giorgio Rizzoni, "Design of an Extended-Range Electric Vehicle for the EcoCAR Challenge", ASME 2010 International Design Engineering Technical Conference, August, 2010.
3. J. Meyer, S. Yurkovich, S. Midlam-Mohler, "An AFR Control Architecture Comparison: Phase Lock Loop Versus Duty Cycle Control," 2010 American Controls Conference, June, 2010.
4. R. Maringanti, S. Midlam-Mohler, M. Fang, F. Chiara, M. Canova, "Set-Point Generation using Kernel-Based Methods for Closed-Loop Combustion Control of a CIDI Engine," ASME DSCC2009, September, 2009.
5. J. Meyer, S. Rajagopalan, S. Midlam-Mohler, Y. Guezennec, S. Yurkovich, "Application of an Exhaust Geometry Based Delay Prediction Modal to an Internal Combustion Engine," ASME DSCC2009, September, 2009.
6. M. Fang, S. Midlam-Mohler, R. Maringanti, F. Chiara, M. Canova, "Optimal Performance of Cylinder-by-Cylinder and Fuel Bank Controllers for a CIDI Engine," ASME DSCC2009, September, 2009.
7. S. Midlam-Mohler, E. Marano, S. Ewing, D. Ortiz, G. Rizzoni, "PHEV Fleet Data Collection and Analysis," IEEE VPPC09, September 2009.
8. L. Headings, G. Washington, S. Midlam-Mohler, J. Heremans, "Thermoelectric Power Generation for Hybrid-Electric Vehicle Auxiliary Power," Proc. SPIE Int. Conference on Smart Structures and Materials, 2009, Vol. 7290, No. 13.
9. M. Canova, S. Midlam-Mohler, G. Rizzoni, F. Steimle, D. Boland, M. Bargende, "A Simulation Study of an E85 Engine APU for a Series Hybrid Electric Vehicle," 9th Stuttgart International Symposium on Automotive and Engine Technology, Stuttgart, Germany, 2009.
10. S. Rajagopalan, S. Midlam-Mohler, S. Yurkovich, Y. Guezennec, K. Dudek, "Control Oriented Modeling of a Three Way Catalyst Coupled with Oxygen Sensors," ASME Dynamic System and Controls Conference, Ann Arbor, MI, 2008.
11. L. Headings, S. Midlam-Mohler, G. Washington, and J. P. Heremans, "High Temperature Thermoelectric Auxiliary Power Unit for Automotive Applications," ASME Conference on Smart Materials, Adaptive Structures and Intelligent Systems, 2008, Paper #610.
12. K. Sevel, M. Arnett, K. Koprubasi, C. Coburn, M. Shakiba-Heref, K. Bayar, G. Rizzoni, Y. Guezennec, S. Midlam-Mohler, "Cleaner Diesel Using Model-Based Design and Advanced Aftertreatment," SAE 2008-01-0868, 2008 International Congress, Detroit, MI, April 2008.
13. K. Dudek, B. Montello, J. Meyer, S. Midlam-Mohler, Y. Guezennec, and S. Yurkovich, "Rapid Engine Calibration for Volumetric Efficiency and Residuals by Virtual Engine Mapping," International Congress on Virtual Power Train Creation 2007, Munich, Germany, October 24-25, 2007.
14. M. Canova, S. Midlam-Mohler, Y. Guezennec, A. Soliman, and G. Rizzoni, "Control-Oriented Modeling of NOx Aftertreatment Systems," SAE ICE'07 Conference, Capri, Italy, September 2007.
15. M. Canova, F. Chiara, J. Cowgill, S. Midlam-Mohler, Y. Guezennec, G. Rizzoni, "Experimental Characterization of Mixed-Mode HCCI/DI Combustion on a Common Rail Diesel Engine," 8th International Conference on Engines for Automobile (ICE2007), Capri, Italy.
16. M. Canova, F. Chiara, M. Flory, S. Midlam-Mohler, Y. Guezennec, G. Rizzoni, "Experimental Characterization of Mixed Mode HCCI/DI Combustion on a Common Rail Diesel Engine," submitted to SAE ICE'07 Conference, Capri, Italy, September 2007.

17. M. Canova, M. Flory, Y. Guezennec, S. Midlam-Mohler, G. Rizzoni, and F. Chiara, "Dynamics and Control of DI and HCCI Combustion in a multi-cylinder Diesel engine," Paper 44, submitted to 5th IFAC Symposium on Advances in Automotive Control, Pajaro Dunes/Seascape, CA, August 2007.
18. A. Vosz, S. Midlam-Mohler, and Y. Guezennec, "Experimental Investigation of Switching Oxygen Sensor Behavior Due to Exhaust Gas Effects," Proc. of IMECE '06, Paper IMECE 2006-14915, Chicago, IL, November 2006.
19. S. Midlam-Mohler and Y. Guezennec, "A Temperature-Based Technique for Temporally and Spatially Resolved Lean NO_x Trap Catalyst NO_x Measurements," Proc. of IMECE '06, Paper IMECE 2006-14887, Chicago, IL, November 2006.
20. M. Canova, S. Midlam-Mohler, Y. Guezennec, G. Rizzoni, L. Garzarella, M. Ghisolfi, and F. Chiara, "Experimental Validation for Control-Oriented Modeling of Multi-Cylinder HCCI Diesel Engines," Proc. of IMECE '06, Paper IMECE 2006-14110, Chicago, IL, November 2006.
21. A. Soliman, S. Midlam-Mohler, Z. Zou, Y. Guezennec, and G. Rizzoni, "Modeling and Diagnostics of NO_x Aftertreatment Systems," Proc. FISITA '06, Yokohama, Japan, October 2006.
22. Z. Zou, S. Midlam-Mohler, R. Annamalai, Y. Guezennec, V. Subramaniam, "Literature Survey of On-Board Hydrogen Generation Methods for Diesel Powertrains," Global Powertrain Conference, Novi, MI, Not Peer Reviewed, September 2006.
23. K. Follen, S. Midlam-Mohler, Y. Guezennec, "Diesel Particulate Filter Regeneration with an External Burner," Global Powertrain Conference, Novi, MI, Not Peer Reviewed, September 2006.
24. S. Midlam-Mohler and Y. Guezennec, "Regeneration Control for a Bypass-Regeneration Lean NO_x Trap System," American Control Conference '06, Minneapolis, MN, Invited paper, June 2006.
25. A. Soliman, I. Choi, S. Midlam-Mohler, Y. Guezennec, G. Rizzoni, "Modeling and Diagnostics Of NO_x After-Treatment Systems," SAE Paper 2006-05-0208, 2006 International Congress, Detroit, MI, April 2006.
26. S. Midlam-Mohler and Y. Guezennec, "Design, Modeling and Validation of a Flame Reformer for LNT External By-Pass Regeneration," SAE Paper 2006-01-1367, 2006 SAE International Congress, Detroit, MI, April 2006.
27. S. Midlam-Mohler, and Y. Guezennec, "Modeling of a Partial Flow Diesel, Lean NO_x Trap System," Proc. of IMECE '05, Paper IMECE 2005-80834, Orlando, FL, November 2005.
28. M. Canova, L. Garzarella, M. Ghisolfi, S. Midlam-Mohler, Y. Guezennec, and G. Rizzoni, "A Control-Oriented Mean-Value Model of HCCI Diesel Engines with External Mixture Formation," Proc. of IMECE '05, Paper IMECE 2005-79571, Orlando, FL, November 2005.
29. A. Soliman, P. Jackson, S. Midlam-Mohler, Y. Guezennec, and G. Rizzoni, "Diagnosis of a NO_x Aftertreatment System," ICE 2005 7th International Conference on Engines for Automobiles, Capri, Italy, September 2005.
30. M. Canova, L. Garzarella, M. Ghisolfi, S. Midlam-Mohler, Y. Guezennec, and G. Rizzoni, "A Mean-Value Model of a Turbo-Charged HCCI Diesel Engine with External Mixture Formation," ICE 2005 7th International Conference on Engines for Automobiles, Capri, Italy, September 2005.
31. M. Canova, R. Garcin, S. Midlam-Mohler, Y. Guezennec, and G. Rizzoni, "A Control-Oriented Model of Combustion Process in HCCI Diesel Engines," American Control Conference '05, Portland, OR, June 2005.
32. C. Musardo, B. Staccia, S. Midlam-Mohler, Y. Guezennec, and G. Rizzoni, "Supervisory Control for NO_x Reduction of an HEV with a Mixed-Mode HCCI/CIDI Engine," American Control Conference '05, Portland, OR, June 2005.
33. M. Canova, A. Vosz, D. Dumbauld, R. Garcin, S. Midlam-Mohler, Y. Guezennec, and G. Rizzoni, "Model and Experiments of Diesel Fuel HCCI Combustion with External Mixture Formation," 6th Stuttgart International Symposium on Motor Vehicles and Combustion Engines, Stuttgart, Germany, Not peer reviewed, February 2005.
34. S. Midlam-Mohler, S. Haas, Y. Guezennec, M. Bargende, G. Rizzoni, S. Haas, and H. Berner, "Mixed-Mode Diesel HCCI/DI with External Mixture Preparation," Paper F2004V258, Proc. FISITA '04 World Congress, Barcelona, Spain, May 2004.
35. Y. Guezennec, C. Musardo, B. Staccia, S. Midlam-Mohler, E. Calo, P. Pisu, and G. Rizzoni, "Supervisory Control for NO_x Reduction of an HEV with a Mixed-Mode HCCI/DI Engine," Paper F2004F233, Proc. FISITA '04 World Congress, Barcelona, Spain, May 2004.
36. M. Gilstrap, G. Anceau, C. Hubert, M. Keener, S. Midlam-Mohler, K. Stockmeier, J-M Vespasien, Y. Guezennec, F. Ohlemacher, and G. Rizzoni, "The 2002 Ohio State University FutureTruck – the BuckHybrid002," 2003 SAE International Congress and Exposition, Detroit, MI, March 2003.

37. Y. Guezennec, S. Midlam-Mohler, M. Tateno, and M. Hopka, "A 2-Stage Approach to Diesel Emission Management in Diesel Hybrid Electric Vehicles," Proc. 2002 IFAC Meeting, Barcelona, Spain, July 2002.
38. M. Hopka, A. Brahma, Q. Ma, S. Midlam-Mohler, G. Paganelli, Y. Guezennec, and G. Rizzoni, "Design, Development and Performance of Buckeyebriid: The Ohio State Hybrid Electric FutureTruck 2001," SAE SP-1701, Not peer reviewed, March 2002.

Scholarly Presentations Independent of Paper Publications:

1. S. Midlam-Mohler and Y. Guezennec, "Lean NOx Trap Modeling Based on Novel Measurement Techniques," CLEERS Conference Workshop 3, Not peer reviewed, May 4, 2006.
2. S. Midlam-Mohler, and Y. Guezennec, "Design, Modeling and Validation of a Flame Reformer for LNT External By-Pass Regeneration," 2005 DEER Conference, Chicago, IL, Not peer reviewed, August 2005.
3. M. Canova, S. Midlam-Mohler, Y. Guezennec, and G. Rizzoni, "Control-Oriented Modeling of HCCI Combustion," 2005 DEER Conference, Chicago, IL, Not peer reviewed, August 2005.
4. S. Midlam-Mohler and Y. Guezennec, 2004 DEER Conference, San Diego, CA, Not peer reviewed, August 2004.
5. S. Midlam-Mohler, Y. Guezennec, G. Rizzoni, M. Bargende, and S. Haas, "Mixed-Mode Diesel HCCI with External Mixture Preparation," 2003 DEER Conference, Newport, R. I., Not peer reviewed, August 2003.
6. S. Midlam-Mohler, Y. Guezennec, "An Active, Thermo-Chemically Managed Diesel NOx After-Treatment System," CLEERS Conference Workshop 2, Not peer reviewed, October 11, 2001.

Intellectual Property Activity

Issued Patents:

1. S. Midlam-Mohler, B. Masterson, "System System for Controlling NOx Emissions During Restarts of Hybrid and Conventional Vehicles," U.S. Patent 7,257,493, awarded 3/21/07.
2. S. Midlam-Mohler, "System and Method for Reducing NOx Emissions after Fuel Cut-Off Events," U.S. Patent 7,051,514, awarded 5/30/06.

Patent Applications:

1. S. Liu, K. Dudek, S. Rajagopalan, S. Yurkovich, Y. Hu, Y. Guezennec, S. Midlam-Mohler, "Off-Line Calibration of Universal Tracking Air Fuel Ratio Regulators," U.S. Patent Application 20090271093, 10/29/2009.
2. S. Rajagopalan, K. Dudek, S. Liu, S. Yurkovich, S. Midlam-Mohler, Y. Guezennec, Y. Hu, "Universal Tracking Air-Fuel Regulator for Internal Combustion Engines, U.S. Patent Application 20090266052, 10/29/2009.
3. K. Dudek, S. Rajagopalan, S. Yurkovich, Y. Guezennec, S. Midlam-Mohler, L. Avallone, I. Anilovich, "Air Fuel Ratio Control System for Internal Combustion Engines," U.S. Patent Application 20090048766, 2/19/2009.
4. Y. Guezennec and S. Midlam-Mohler, Shawn, "Fuel Preparation System for Combustion Engines, Fuel Reformers and Engine Aftertreatment," U. S. Patent Application 20040124259, 7/1/04
5. S. Midlam-Mohler and B. Masterson, "System and Methods for the Reduction of NOx Emissions after Fuel Cut-Off Events," U.S. Patent application 20060021326, filed 2/2/03.
6. S. Midlam-Mohler and B. Masterson, "Strategy for Controlling NOx Emissions During Hot Restarts for Hybrid and Conventional Vehicles," U.S. Patent Application 20060021330, filed 2/2/03.

Patent Applications in Preparation:

1. J. Meyer, S. Midlam-Mohler, K. Dudek, S. Yurkovich, Y. Guezennec, Topic: Engine emissions control, Status: submitted to patent office 9/09.
2. J. Meyer, S. Midlam-Mohler, K. Dudek, S. Yurkovich, Y. Guezennec, Topic: Engine emissions control, Status: submitted to patent office 9/09.
3. S. Midlam-Mohler, S. Rajagopalan, K. Dudek, S. Yurkovich, Y. Guezennec, Topic: Catalyst modeling for improved emissions control, Status: Patent application being prepared by outside counsel.

Curriculum Vitae

ELLIOTT ORTIZ-SOTO

EDUCATION

UNIVERSITY OF MICHIGAN – ANN ARBOR (U – M) **In Progress** **Ann Arbor, MI**
PhD Pre-Candidate in Mechanical Engineering (4th Year)

Relevant Graduate Coursework: Turbulent Combustion, Turbulent Flow, Combustion Processes, Advanced Internal Combustion Engines, Hybrid Electric Vehicles, Gas Turbine Propulsion, Advanced Heat Transfer, Advanced Fluid Mechanics, Advanced Thermodynamics, Computational Fluid Dynamics, Internal Combustion Engines, Heat Transfer Physics, Partial Differential Equations, Probability & Statistics

UNIVERSITY OF MICHIGAN – ANN ARBOR **May 2010** **Ann Arbor, MI**
Master of Science in Mechanical Engineering

Thesis: Dual-Mode SI-HCCI Operation for Improved Drive-Cycle Fuel Economy: Modeling Framework Development and Implementation in Comparative Fuel-Economy Study

MASSACHUSETTS INSTITUTE OF TECHNOLOGY (MIT) **June 2006** **Cambridge, MA**
Bachelor of Science in Mechanical Engineering **GPA: 4.2/5.0**

Language Concentration in German

Thesis: Design of Oil Consumption Measuring System to Determine the Effects of Evolving Oil Sump Composition over Time on Diesel Engine Performance and Emissions

RESEARCH

WALTER E. LAY AUTOMOTIVE LAB (U – M) **Fall 2007 – Present** **Ann Arbor, MI**

- Researching the physics behind novel combustion approaches, involving high pressures, ultra high dilution, spark-assisted compression ignition (SACI) and alternative fuels, and began combustion modeling and coding work for the implementation in GT-Power as user-developed subroutines.
- Developed complete heat release analysis program in Matlab for improved experimental heat release analysis of multi-mode combustion engines and future combustion model development.
 - ❖ Increased computational speed and functionality through full Matlab implementation
 - ❖ Superior accuracy in temperature, heat transfer and heat release calculations through:
 - Better properties estimation using in-house properties and equilibrium functions (based on JANAF tables).
 - Updated residual estimation techniques for unconventional valve actuation strategies.
 - Single-zone and two-zone heat release analysis options to account for various combustion modes.
 - ❖ Fully functional Matlab GUI for enhanced utility and ease of use.
- Developed complete modeling and simulation framework for fuel-economy evaluation and mode transition studies of Dual-Mode SI-HCCI engines involving:
 - ❖ Detailed system-level engine models of spark-ignition (SI) and HCCI engines using GT-Power
 - ❖ Experimental validation of engine, combustion, heat transfer, knock, and emissions submodels based on Fully-Flexible Valve Actuation Engine at the U-M Auto Lab.
 - ❖ Full range SI and HCCI engine operating map generation using Design of Experiments optimization
 - ❖ Flexible architecture vehicle model using a coupled GT-Suite/Simulink approach for intuitive physical modeling and improved controls development
 - ❖ Drive-cycle simulations to assess real fuel-economy benefits of Dual-Mode SI-HCCI operation over conventional SI engines
- Performed simulation study exploring the potential synergy between the HCCI engine system and three hybrid electric vehicle (HEV) configurations, proposed the supervisory control strategy to maximize the benefits combining the two technologies.

- ❖ Developed Matlab/Simulink conventional, split-hybrid and parallel-hybrid vehicle models
- ❖ Implemented fuel-consumption maps for SI and HCCI engines and created bsfc-optimized shifting strategies for each engine operating mode.
- ❖ Developed rule-based control strategy to maximize HCCI engine operation and minimize mode transitions
- Developed new HCCI engine cycle simulation using a zero-dimensional thermodynamic combustion approach with detailed chemical kinetics within the Cantera-Matlab environment, and investigated the effects of engine speed, fueling and variable valve actuation on ignition timing
- Proposed practical design to achieve constant-volume combustion using advanced split-cycle engine concept and performed a modeling study to compare efficiency benefits over conventional and other split-cycle engines.

OAK RIDGE NATIONAL LABORATORY (ORNL) Summer 2010 Oak Ridge, TN
Fuels, Engines and Emissions Research Center (FEERC)

- Started work on improved experimental engine heat release analysis program for in-depth evaluation of multi-mode combustion, model development and validation.
- Researched current state-of-the-art flame propagation and chemical kinetics models for SI and HCCI combustion simulation, and evaluated their possible implementation as simplified models for system-level simulations.

OAK RIDGE NATIONAL LABORATORY (ORNL) Summer 2009 Oak Ridge, TN
Fuels, Engines and Emissions Research Center (FEERC)

- Began work on comprehensive, physics-based Spark-Assisted HCCI model for use in system-level simulations.
- Presented in detail components and implementation of the U-M HCCI Combustion correlation.
- Developed improved GT-Power engine model of experimental single-cylinder engine with fully-flexible valve actuation capable of multi-mode SI and HCCI operation.
- Performed validation study of engine and combustion models with available experimental data.

SLOAN AUTOMOTIVE LABORATORY (MIT) Fall 2005 – Spring 2006 Cambridge, MA

- Set up experimental single-cylinder diesel engine for emissions and oil consumption studies
- Studied formation and evolution of inorganic emissions from different diesel fuel compositions and evaluated its effect on diesel particulate filter performance

WORK EXPERIENCE

M RACING Fall 2009 – Present Ann Arbor, MI
Formula SAE Powertrain Division

- Serving as experienced modeling consultant for development of improved engine model in GT-Power.
- Current engine model capable of reproducing similar experimental engine behavior; expected improvements with further model enhancements in near future.

FORD MOTOR COMPANY Summer 2008 Dearborn, MI
Intern – Transmission/Driveline Research & Advanced Engineering

- Performed hydraulic, transmission and vehicle level simulations (Matlab/Simulink & Ford Software), validated models with experimental data for *Stop-Start w/ Assisted Direct Start (Micro-Hybrid)* technology development.
- Studied formation and evolution of inorganic emissions from different diesel fuel compositions and evaluated its effect on diesel particulate filter performance.

FORD MOTOR COMPANY Summer 2007 Livonia, MI
Intern – Automatic Transmission New Product Center (Electro-Hydraulic Components)

- Assessed theoretical performance of competitive 6-speed automatic transmission pumps.
- Established target comparison metrics and presented preliminary data suggesting design improvements for increased efficiency.

ZF FRIEDRICHSHAFEN AG July 2006 – December 2006 Friedrichshafen, Germany
Intern – Automatic Transmission New Product Center (Electro-Hydraulic Components)

- Worked on new simulation approaches with Dymola (Modelica) and prepared training material for new users.
- Researched new control techniques for disturbance reduction in future hybrid transmission systems.
- Optimized powertrain/vehicle level models for real-time simulations (DSpace) used in pre-development and serial production projects.

FORD MOTOR COMPANY

Summer 2005

Dearborn, MI

Intern – Automatic Transmission New Product Center (Electro-Hydraulic Components)

- Tested and analyzed competitive air induction system performance in environmental wind tunnels.
- Presented data to recommend and support possible air induction system redesign/placement.

MIT MOTORSPORTS

Fall 2005 – Spring 2006

Cambridge, MA

Formula SAE Powertrain Division

- Redesigned complete formula race car air induction system.

PUBLICATIONS

- **Ortiz-Soto, E.**, Babajimopoulos, A., Lavoie, G., Assanis, D., “A Comprehensive Engine to Drive-Cycle Modeling Framework for the Evaluation of Future Engine and Combustion Technologies,” International Journal of Engine Research (IJER). (Submitted)
- Lawler, B., **Ortiz-Soto, E.**, Gupta, R., Peng, H., and Filipi, Z.S, “Hybrid Electric Vehicle Powertrain and Control Strategy Optimizatio to Maximize the Synergy with a Gasoline HCCI Engine,” SAE Paper 11PFL-0963. (Submitted)
- Delorme, A., Rousseau, A., Wallner, T., **Ortiz-Soto, E.**, Babajimopoulos, A., and Assanis, D., “Evaluation of Homogeneous Charge Compression Ignition (HCCI) Engine Fuel Savings for Various Electric Drive Powertrains,” The 25th World Battery, Hybrid and Fuel Cell Electric Vehicle Symposium & Exhibition, Shenzhen, China, November 5-9, 2010.

PRESENTATIONS

- **Ortiz-Soto, E.**, Babajimopoulos, A., Lavoie, G., and Assanis, D., “Dual-Mode SI-HCCI Operation for Improved Drive-Cycle Fuel Economy: Engine Modeling and Map Generation Framework,” USCAR, May 12, 2010
- **Ortiz-Soto, E.**, Babajimopoulos, A., Lavoie, G., and Assanis, D., “Dual-Mode SI-HCCI Operation for Improved Drive-Cycle Fuel Economy: Modeling Framework Development,” Low Temperature Combustion (LTC) University Consortium Meeting, USCAR, October 7-8, 2010

PROFESSIONAL DEVELOPMENT

- *GT-Power Advanced Training Seminar*, November 2010
- Direction in Engine-Efficiency and Emissions Research (DEER) Conference, September 2010
- High-Pressure Lean Burn (HPLB) Consortium Meeting, USCAR, October 2010
- Princeton-CEFRC Summer Program on Combustion: 2010 Session, June 27 – July 3, 2010
- Low Temperature Combustion (LTC) Consortium Meeting, USCAR, October 2009
- WINDPOWER 2009 Conference, May 2009
- Society of Automotive Engineering (SAE) World Congress, April 2008
- *High Performance Engine Design and Development Seminar*, April 2008
- U-M Graduate School Recruiter @ SHPE Conference, October 2007
- Certified Engineering in Training (E.I.T)

AWARDS & ACHIEVEMENTS

- 2010 and 2009 ScholarPOWER Award for Master’s Student Achievement, University of Michigan – Ann Arbor
- Awarded GEM Fellowship for PhD (2009) and Master’s (2007) studies in Mechanical Engineering
- 2006 and 2005 Lufthansa Award for Excellence in German Studies, Massachusetts Institute of Technology

PROFESSIONAL ORGANIZATIONS

- Society of Automotive Engineers (SAE)

- American Society of Mechanical Engineers (ASME)
- Society of Hispanic Professional Engineers (SHPE)
- Alliance for Graduate Education and the Professoriate (AGEP)
- Latino Engineering Graduate Organization (LEGO)

SKILLS

- **Languages:** Fully bilingual and bicultural (English and Spanish). Fluent in German.
- **Computer:** Matlab/Simulink, GT-Power/GT-Suite, Fortran, Mathematica, Fluent, SolidWorks and MS Office

Aris Babajimopoulos
2325 Leslie Circle
Ann Arbor, MI 48105

12/22/2010

Tony Lentz
RTI International
3040 Cornwallis Road
RTP, NC 27709

Dear Mr. Lentz,

Enclosed is my review of the EPA GEM model. In reviewing the material, I did not encounter any real or perceived conflicts of interest. Please note that this review was conducted outside of my normal job duties as an Asst. Research Scientist at the W.E. Lay Automotive Laboratory of the University of Michigan.

I appreciate the opportunity to review the EPA GEM model and hope that my comments are helpful. I would be happy to address any questions or concerns that may arise.

Sincerely,

Aris Babajimopoulos, PhD

enclosure

Daniel L. Flowers, Ph.D.
San Leandro, CA 94577
dlfenergyconsulting@gmail.com

12/27/2010

Tony Lentz
RTI International
3040 Cornwallis Road
RTP, NC 27709

Mr. Lentz,

Enclosed is my review of the EPA GEM model. In reviewing the material, I did not encounter any real or perceived conflicts of interest. This review was conducted as a private consultant outside of my normal job duties as a member of the technical staff at Lawrence Livermore National Laboratory.

I appreciate the opportunity to review the model and hope that my comments are helpful to the review process.

Sincerely,

Daniel L. Flowers

enclosure

3938 Norbrook Drive
Columbus, Ohio 43220
12/11/2010

Tony Lentz
RTI International
3040 Cornwallis Road
RTP, NC 27709

Mr. Lentz,

Enclosed is a review of the EPA GEM model. In reviewing the material, I did not encounter any real or perceived conflicts of interest. This review was conducted outside of my normal job duties as a Research Scientist at the Ohio State University Center for Automotive Research; however, my experience from this position was invaluable for conducting the review.

I appreciate the opportunity to review the model and hope that my comments are helpful to the review process.

Sincerely,

Shawn Midlam-Mohler

enclosure

2373 Leslie Circle
Ann Arbor, MI 48105
01/11/2011

Tony Lentz
RTI International
3040 Cornwallis Road
RTP, NC 27709

Mr. Lentz,

Enclosed is a review of the EPA's Greenhouse-Gas Emissions Model (GEM). During the review process, I did not encounter any real or perceived conflicts of interest. This peer review was conducted outside of my normal job duties as a Research Assistant at the University of Michigan Walter E. Lay Automotive Laboratory; however, my work at the lab has provided me with the knowledge and experience that was indispensable for conducting the review.

I appreciate the opportunity to become part of the reviewer team and hope this review provides some useful feedback in the development and improvement of the GEM compliance simulation tool.

Best regards,

Elliott Ortiz-Soto

enclosure

Review of Greenhouse gas Emissions Model (GEM)

Reviewer: Aris Babajimopoulos, PhD
Dept. of Mechanical Engineering
University of Michigan

Documents reviewed:

1. Greenhouse Gas Emissions Model (GEM) User Guide
EPA-420-B-10-039 (October 2010)
Filename: 420b10039.pdf
2. gem-v1.0-executable.zip
3. gem-v1.0-matlab.zip

Introduction

The new Greenhouse gas Emissions Model (GEM), developed by EPA as a tool for the determination of compliance with the newly proposed GHG emissions and fuel economy standards for Class 7 and 8 combination tractors and Class 2b-8 vocational vehicles, is essentially a very detailed and complex transient truck simulation. The stated goal of EPA for GEM is the assessment of the impact of tractor cab design (through its effect on drag coefficient) and/or truck tires (through changes in rolling resistance and weight reduction) on a vehicle's compliance with the new standards. The main objectives of this review can be summarized as follows:

1. Assess the model's completeness and functionality and check for errors (technical or of implementation).
2. Comment on EPA's overall approach to the stated purpose of the model.

The review is organized as follows: First comments are offered on the main model components and assumptions, as found in the Matlab/Simulink version of GEM, followed by some general comments on the Matlab code. Then some comments on the GEM user guide are provided, followed by comments on the GEM executable. Finally, there is a discussion about the appropriateness of GEM as a tool for determining vehicle compliance.

Main model components and assumptions

The model is indeed very complete and covers all these components that affect overall vehicle performance and fuel economy. The Simulink model is well organized. The use of many Goto and From blocks allows for a clean model; however it makes it a little more difficult to follow for someone who is not familiar with the model. The Matlab codes are also very well structured, well documented and easy to follow.

After detailed examination of the model, I have reached the conclusion that the assumptions used in the model are reasonable and the model itself is free of major errors of implementation. I only have three comments: one addresses the complexity of the submodel for the electric system; one touches on the fact that engine fuel maps, transmission and final drive are prescribed in the model; and one has to do with the default value for the density of air. To facilitate the discussion, Table 1 includes the inputs and simulation results for a baseline vehicle (Class 8 – Sleeper cab – high roof, MY 2010), as well as several results for runs with the same exact vehicle and single parameter variation.

Electric system submodel

The model of the electric subsystem is particularly detailed and convoluted. GEM includes submodels for the starter, alternator, battery and electric accessories. This complexity seems unnecessary for the stated purposes of GEM. Careful examination of the results reveals that the starter has almost zero effect on overall fuel economy and CO₂ emissions. Moreover, the overall effect of the electrical system on fuel economy and CO₂ emissions is almost negligible. Table 1 shows that if the electric load is totally ignored (by overriding the

elec_torq signal and setting it to zero), the simulation results change by 0.2-0.4% for all tests.

Unless it is intended in the future to use GEM for the simulation of hybrid vehicles, it is hard to justify such model complexity, particularly since the load from the mechanical accessories is simply modeled as a constant power demand. It would be just as simple to model the electric load as a constant power demand. Doing something along these lines, i.e. adding the value of `electric.acc.power` to `engine.acc.power` and then setting `electric.acc.power` to zero, produces results very close to the baseline ones for the steady state cycles and the weighted fuel consumption and is off by 0.5% for the transient cycle.

Engine, transmission and final drive

It is stated in the GEM user guide, that EPA is primarily interested in assessing the impact of aerodynamic drag coefficient, tire rolling resistance and tire weight reduction on fuel economy and CO2 emissions. For this purpose, engine fuel maps and drivetrain parameters are hardwired in the model and the user has no option of changing them. However, it seems counterintuitive that a tool for determining compliance with emissions standards would ignore efforts on the part of the manufacturers to make improvements on the engine itself. Moreover, in order to take full advantage of any improvements in combustion and engine-out emissions, the vehicle transmission needs to be optimized for a particular vehicle/engine/driving schedule combination, so that the engine can operate near its optimum efficiency points at all times. To illustrate this point, Table 1 includes a comparison of the baseline vehicle, with final drive ratio equal to 2.64:1, with the same vehicle but with final drive ratio changed to 2.77:1. This relatively small change in final drive ratio (~5%), results in worse fuel economy for all tests (on the order of 3%), simply by forcing the engine to operate at a less efficient region of the fuel map.

This point will be revisited in the discussion on the appropriateness of GEM as a tool for determining vehicle compliance.

Density of air

The specified air density value (1.1071 kg/m³) in 'ambient_param.m' seems to be rather low. Using the gas constant for air (287 J/kg.K) and the specified temperature (293 K) and pressure (101325 Pa), the density can be calculated to be 1.205 kg/m³. As it can be seen in Table 1, this difference of around 8.8% in air density does not have a great impact on the model predictions for the transient cycle (approximately 0.5%), however it changes the results for the steady-state cycles by 4-5% (worse fuel economy, due to increased drag).

General comments on the Matlab code

- Cross-platform compatibility: Using the hardwired file separator (\) makes the model incompatible with platforms other than windows. Consider defining file

names using the Matlab function 'fullfile'. For example, instead of the command `load('drive_cycles\ARB_Transient')`, one can use the command `load(fullfile('drive_cycles', 'ARB_Transient'))`. The Matlab model contains a total of 3 `load` and 10 `run` statements using the `\` separator. By making the aforementioned change 13 times, I was able to execute the Matlab model on both a Mac and a Linux machine.

- **Robustness:** Code contains hooks for future additions, but some of them seem unnecessary. For example, `i_sim` as a case number index is hardwired to be equal to 1. If the value changed, the code would not work without modifications, considering that the arrays it points to have not been defined as such (`veh_type`, `c_d`, `c_rr_steer`, etc.). Currently the code works only because `i_sim` is always equal to 1.

General comments on the GEM user guide

The GEM user guide is overall well written and clear. There are only some minor issues:

- The model description is too detailed, referring to features of the model that are irrelevant and outside the scope of GEM, even though these features are present in the model. For example, there is reference to the road gradient that can be specified, although this is never actually done; it is stated that either a 12 or 24 volt standard lead acid can be modeled, although in reality only one type of battery is modeled; in the description of the Mechanical Accessory Block, Power Take Off is mentioned. This detailed description of the model may generate unnecessary confusion to the users of GEM.
- In the discussion of the Electric Accessory component of the model, it is stated that "all vehicles have a number of electrical loads...and these are already taken into account in the fuel map." This is a troubling statement. It is indeed standard practice to include accessory loads (both electrical and mechanical) in the fuel map, by effectively changing the brake torque of the fuel map. However, in GEM, the electrical load is actually calculated at every time step, which means that the fuel maps that are used should not include the impact of any accessory loads. Hopefully, this is indeed the case and this statement was included by error.

GEM download, installation and execution

The download and installation instructions, which are included in the GEM user guide, are very clear. Installation was absolutely trouble free.

Comments on GEM executable

- The coefficient of aerodynamic drag can only be specified with a pull-down list of values from 0.50 to 0.85, with step 0.05. As a result, not all intermediate values for C_d can be specified, including the recommended values provided by EPA in Table 5

(e.g. 0.69, 0.76, 0.81 etc.). Considering the significant impact of Cd on fuel economy and its importance in achieving compliance, the value of Cd should be allowed to be entered in a textbox.

- In the GEM user guide, it is stated that the coefficient of drag is only required for combination tractors and *no input is required* for vocational trucks (page 8). However, when one selects the Heavy Heavy-Duty vocational vehicle, it is still possible to change the value of Cd through the pull-down menu. Moreover, the selected value seems to indeed influence the fuel economy prediction. Similarly to Cd, the GEM user guide states that the input for Vehicle Speed Limiter is only available for combination tractors and no input is *allowed* for vocational trucks. Nevertheless, it is indeed possible to enter a value for vehicle speed limiter for a vocational truck and this value has an effect on overall fuel economy. Table 2 shows the inputs and results for 3 simulated cases for a Heavy Heavy-Duty vocational truck. The first case is the baseline case. The inputs for the second case are the same as the baseline ones, except that Cd is changed from 0.8 to 0.6. Similarly, for the third case, all inputs are the same as the baseline ones, except that the vehicle speed is limited to 55 mph instead of 65 mph. It can be seen clearly in Table 2 that both Cd and speed limiter influence the results for Cases 2 and 3. If this behavior is not desired, either the underlying code should be modified to ignore these inputs for vocational trucks and use the default values or the GUI should be modified, so that when a vocational truck is selected from the regulatory class list, the corresponding input fields should become inactive (“grayed out”).
- Minor comments:
 - It would be good if the message indicating where the results will be stored also include the drive (C:) in the path (e.g. ‘C:\GEM_Results\December_14_2010-0135PM instead of \GEM_Results\December_14_2010-0135PM’)
 - The fact that the three figures must be closed one after the other before the program execution ends is a little confusing, at least initially. It would be nice if this behavior could change.

GEM as a tool for determining vehicle compliance

GEM is a very detailed vehicle simulation that could capture with reasonable accuracy the impact of changes in aerodynamic drag coefficient, tire rolling resistance and tire weight reduction on overall vehicle fuel economy and CO2 emissions. The model itself is almost too detailed for this purpose, but this should not be a problem, provided that not all details of the model are discussed in such great length with the users.

However, as mentioned in the discussion about the engine, transmission and final drive, it is hard to envision a compliance tool that does not account for fuel economy improvements coming from the development of advanced combustion technologies by the engine manufacturers. If the assumption is that engines will be relatively similar for the same class

vehicles coming from different manufacturers, then it is safe to assume that GEM would be an appropriate tool for determining compliance with fuel economy and CO2 emissions standards based on vehicle design changes alone. Nevertheless, if it were anticipated that trucks of the same class from different manufacturers would use engines with significantly different fuel maps, it would be proper to allow for the provision to change the engine fuel map and transmission characteristics used by GEM.

Table 1. Effects of the variation of various model parameters on the simulation results for a baseline vehicle (Class 8 – Sleeper cab – high roof, MY 2010)

	Baseline	No electrical accessories	Electrical acc. power added to mechanical acc. power	Final drive equal to 2.77 instead of 2.64	Air density equal to 1.205 instead of 1.1071
Model Inputs					
Coefficient of Aerodynamic Drag	0.69				
Steer Tire Rolling Resistance [kg/metric ton]	7.8				
Drive Tire Rolling Resistance [kg/metric ton]	8.2				
Vehicle Speed Limiter [mph]	N/A				
Vehicle Weight Reduction [lbs]	N/A				
extendedIdleReductionLabel	N/A				
Transient Cycle Simulation					
Fuel Consumption for Entire Cycle [mpg]	3.51	3.51	3.49	3.38	3.49
CO2 Emissions [g/ton-mile]	152.86	152.52	153.64	158.68	153.41
55 mph Steady-State Cycle Simulation					
Fuel Consumption during Steady State [mpg]	7.40	7.43	7.41	7.28	7.15
CO2 Emissions [g/ton-mile]	72.38	72.14	72.32	73.59	74.98
65 mph Steady-State Cycle Simulation					
Fuel Consumption during Steady State [mpg]	6.19	6.21	6.20	6.01	5.91
CO2 Emissions [g/ton-mile]	86.52	86.22	86.40	89.22	90.67
Cycle-Weighted Results					
Weighted Fuel Consumption [mpg]	6.17	6.19	6.17	5.99	5.90
--> in gal/1000 ton-mile	8.70	8.67	8.69	8.97	9.08
Weighted CO2 Emission [g/ton-mile]	88.57	88.27	88.49	91.29	92.40

Table 2. Impact of Cd and vehicle speed limiter on the simulation results for a Heavy Heavy-Duty – Vocational Truck (Class 8)

	Case 1	Case 2	Case 3
Model Inputs			
Coefficient of Aerodynamic Drag	0.8	0.6	0.8
Steer Tire Rolling Resistance [kg/metric ton]	9	9	9
Drive Tire Rolling Resistance [kg/metric ton]	9	9	9
Vehicle Speed Limiter [mph]	65	65	55
Vehicle Weight Reduction [lbs]	0	0	0
extendedIdleReductionLabel	0	0	0
Transient Cycle Simulation			
Percent Time Missed by 2mph [%]	1.51	1.5	1.51
Fuel Consumption for Entire Cycle [mpg]	3.51	3.55	3.51
CO2 Emissions [g/ton-mile]	152.74	150.89	152.74
55 mph Steady-State Cycle Simulation			
Percent Time Missed by 2mph [%]	0.23	0	0.23
Fuel Consumption during Steady State [mpg]	6.47	7.24	6.47
CO2 Emissions [g/ton-mile]	82.75	74.04	82.75
65 mph Steady-State Cycle Simulation			
Percent Time Missed by 2mph [%]	0	0	0
Fuel Consumption during Steady State [mpg]	5.34	6.18	6.48
CO2 Emissions [g/ton-mile]	100.41	86.69	82.75
Cycle-Weighted Results			
Weighted Fuel Consumption [mpg]	4.81	5.3	5.23
--> in gal/1000 ton-mile	11.66	10.9	11.02
Weighted CO2 Emission [g/ton-mile]	118.68	111	112.15

Review of EPA GEM model for as a tool for evaluation of medium and heavy-duty vehicle GHG emissions

Daniel L. Flowers, Ph.D.
danflowers@gmail.com

19 Dec 2010

This report reviews the methodology developed by EPA for evaluating greenhouse gas (GHG) emissions reductions from medium and heavy-duty road vehicles [1]. This model focuses on GHG emissions improvements based on vehicle drag reduction and rolling resistance reduction, and would be used by EPA as a regulatory tool to evaluate compliance by vehicle manufacturers.

In general, the goal of this program is to provide a framework for fairly evaluating GHG emissions from medium and heavy-duty vehicles [2]. Thus, a key mission of this review is evaluating how well the modeling approach developed serves as a regulatory and compliance tool.

We reviewers have been asked to comment on the model with regard to 5 specific items:

- 1) EPA's overall approach to the stated purpose of the model (meet agencies' compliance requirements) and whether the particular attributes found in resulting model embodies that purpose.
- 2) The appropriateness and completeness of the contents of the overall model structure and its individual systems, and their component models, if applicable (i.e., using the MATLAB/Simulink version), such as:
 - a) The elements of each system to describe different vehicle categories;
 - b) The performance of each component model, including the reviewer's assessment of the underlying equations and/or physical principles coded into that component.
 - c) The input and output structures and how they interface with the model to obtain the expected result, i.e., fuel consumption and CO₂ over the given driving cycles; and
 - d) The default values used for the input file, as shown in the GEM User Guide.
- 3) Using the standard of good engineering judgment, the program execution is optimized by the chosen methodologies;
- 4) Clarity, completeness and accuracy of the output/results (CO₂ emissions or fuel efficiency output file); and

- 5) Any recommendations for specific improvements to the functioning or the quality of the outputs of the model.

Detailed discussion of each of these items will be described in the following sections.

Item 1) Overall approach

Based on the description of the proposed use in rulemaking (EPA-420-D-10-901) [1], the overall approach is to provide a neutral framework upon which different vehicles from different manufacturers can be compared. The idea of this approach is to eliminate manufacturer differences by looking only at the external vehicle loss characteristics: drag coefficient and coefficients of rolling resistance. For vehicles from different manufacturers in each regulatory subcategory, there are several assumptions made about the vehicle characteristics:

1. The frontal area is the same
2. Accessory power required is the same
3. Vehicle mass is the same
4. Distribution of weight on drive, steering, and trailer tires is the same
5. The engine is the same
6. The transmission and driveline losses are the same

For a regulatory subcategory of vehicles (e.g. Class 8 Sleeper Cab High Roof), assumptions 1, 2, and 3 are very reasonable. Frontal area is likely very similar for subcategory vehicles, and vehicle mass is likely to be similar based on gross vehicle regulated weight. Accessory loads vary from truck to truck and application-to-application, so constant accessory load for all is a reasonable approximation.

Assumptions 4, 5, and 6 are not necessarily fully justified. With regard to assumption 4, for non-vocational trucks, the overall rolling resistance is specified as 42.5% trailer, 42.5% drive wheels, and 15% steering wheels. This has a potential to penalize a vehicle that has reduced cab mass and biased the load towards the trailer. However, it is likely to be a small effect and does not seem likely to be frequently significant.

Assumptions 5 and 6 are more problematic. The engine and transmission can be suitably sized to the load characteristics. In this case, the engine and transmission is not optimized to the vehicle. This issue will be discussed quantitatively and in greater detail in the next section of this review. Consider a Class 8 tractor with a drag coefficient of 0.69 that has the engine optimally sized for the engine and transmission on the drive cycle. Reducing the drag coefficient by 13% to 0.60 will reduce the load requirements, shifting the operation to lower load on the engine. Diesel engine achieve highest efficiency at highest load and efficiency decreases with decreasing load. Thus the lower drag vehicle may operate on a lower efficiency part of the engine map.

In practice, the engine and transmission can be appropriately sized to best take advantage of the reduced overall vehicle load. By requiring only one engine and transmission be used, drag reduction efforts could be penalized.

The danger exists that the manufacturers would be encouraged to optimize vehicles to meet the characteristics that will give the best performance with the simulation tool, instead of optimizing the vehicle to achieve the true goals of reducing fuel consumption and GHG emissions.

Overall, the concept of using a generic vehicle model has merit to limit the need to test the myriad possible vehicle configurations. The use of a generic powertrain (engine and transmission) is problematic because a well-integrated powertrain can significantly improve vehicle performance.

Item 2) Functional aspects of the overall model and model components

This section focuses on verification that the model works as expected, as well as how the model parameters and components affect the prediction of fuel consumption and GHG emissions in context of regulatory use. The first step is a sanity check on the results of the model compared with direct calculation.

Determining fuel consumption analytically requires working backwards from the forces and accelerations on the vehicle to the engine fuel consumption map. Equation 1 shows gross engine power in terms of vehicle parameters based on working backwards from the forces on the vehicle. The full derivation with description of the parameters is in the appendix.

$$P_{engine,gross} = \frac{1}{\eta_{tr}} \left(c_{rr} mg \cos(\beta) V + \frac{1}{2} \rho c_d A_f V^3 + mg \sin(\beta) V + maV + \sum_{k=1}^N (I_k \ddot{\theta}_k \dot{\theta}_k) \right) + P_{acc} \quad (1)$$

At constant speed and zero grade, the net acceleration and gravity terms become zero.

$$P_{engine,gross} = \frac{1}{\eta_{tr}} \left(c_{rr} mg V + \frac{1}{2} \rho c_d A_f V^3 \right) + P_{acc} \quad (2)$$

Table 1 below shows a comparison between the output of the GEM simulation model and torque based on calculating equation (2) for the same parameters. The vehicle configuration used for Table 1 is from the GEM manual for the “Class 8 Combination - Sleeper Cab - High Roof [ref].” Torque is compared for the constant speed portions of the 55 mph drive cycle and the 65 mph drive cycle.

The GEM simulation code calculates engine torque and speed, not power directly. In Table 1 the engine speed from the GEM simulation is used with the analytically determined power to determine analytical engine torque.

Table 1 – Comparison of GEM simulation predictions to the calculations based on equations derived in Appendix 1. Comparisons are for “veh_type(i_sim) = 1” “Class 8 Combination - Sleeper Cab - High Roof.” The engine is the first map “veh_year=1” in engine_map_455.m

Property	Units	55 mph	65 mph	Source
Air density	kg/m ³	1.1071	1.1071	GEM model: ambient_param.m
Gravitational acceleration	m/s ²	9.8066	9.8066	GEM model: ambient_param.m
Vehicle frontal area	m ²	9.8	9.8	GEM model: run_preproc.m
Vehicle static mass	kg	31978	31978	GEM model: run_preproc.m
Drag coefficient	No units	0.69	0.69	Input
Drive wheels coefficient of rolling resistance	No units	0.0082	0.0082	Input
Steer wheels coefficient of rolling resistance	No units	0.0078	0.0078	Input
Trailer wheels coefficient of rolling resistance	No units	0.006	0.006	GEM model: run_preproc.m
Rolling resistance fraction from drive wheels	No units	0.425	0.425	GEM model: run_preproc.m
Rolling resistance fraction from steer wheels	No units	0.15	0.15	GEM model: run_preproc.m
Rolling resistance fraction from trailer wheels	No units	0.425	0.425	GEM model: run_preproc.m
Net coefficient of rolling resistance	No units	0.007205	0.007205	Calculated
Mechanical Accessory Power	W	1000	1000	GEM model: run_preproc.m
Electrical Accessory Power	W	360	360	GEM model: run_preproc.m
Vehicle Speed	Mph	55	65	GEM model: specified by drive cycle (Mild_55_mph.mat, Mild_65_mph.mat)
Vehicle Speed	m/s	24.6	29.1	Calculated
Vehicle acceleration	m/s ²	0	0	GEM model: constant speed section of drive cycle used for analysis
Vehicle driving grade	Degrees	0	0	GEM model: specified by drive cycle (Mild_55_mph.mat, Mild_65_mph.mat)
Aerodynamic force on vehicle	N	2262.8	3160.5	Calculated
rolling resistance force on vehicle	N	2259.5	2259.5	Calculated
Total resistive force on vehicle	N	4522.3	5419.9	Calculated
Vehicle power requirement	kW	111.2	157.5	Calculated
Engine speed	Rpm	1266.5	1495.6	Output from GEM Model: Simulink model "GEM_manual_v1/ engine/ engine/ engine_fuel_flow"
Transmission efficiency	No units	0.98	0.98	Output from GEM Model: Simulink model "GEM_manual_v1/ transmission/ gear/ gear_engaged"
Engine Power required	kW	114.8	162.1	Calculated
Engine Torque	N-m	865.7	1034.8	Calculated (using engine speed from GEM simulation)
Engine Torque	N-m	892.5	1066.2	Output from GEM Model: Simulink model "GEM_manual_v1/ engine/ engine/ engine_fuel_flow"
Difference in analytical versus GEM simulated torque	%	3.0	3.0	Calculated

For this case, the analytical torque is 3% lower than the torque determined by the GEM simulation model. A possible explanation of this discrepancy may come from the formulation of the GEM model. In the GEM model the desired vehicle speed is specified and the vehicle dynamic system responds to try to meet that by providing needed engine torque. The vehicle speed is calculated in the subroutine of the Simulink Model “GEM_manual_v1/vehicle/chassis/vehicle_speed” as shown in Figure 2.

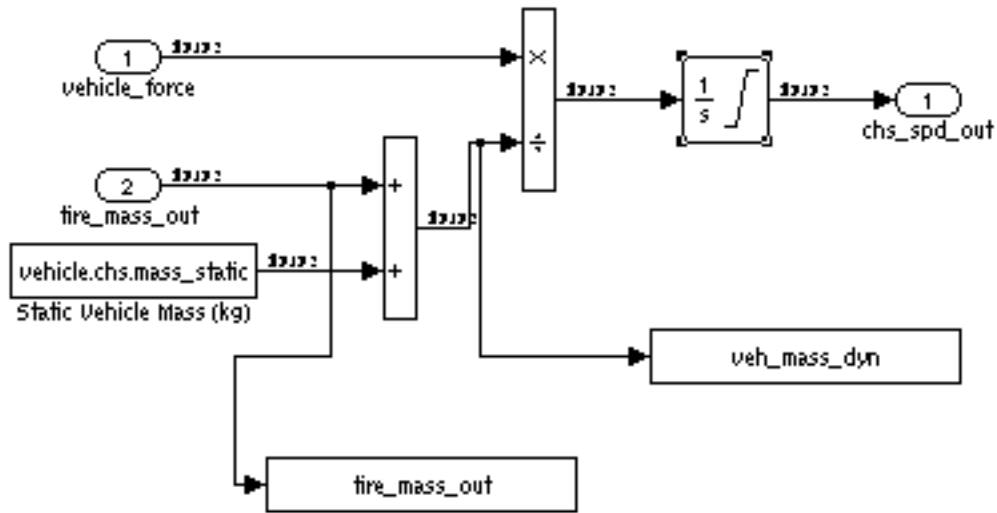

Figure 1 - Section of the GEM Simulink model where vehicle speed is calculated.

The vehicle speed comes from integrating the force balance.

$$\sum F = m_{eff} a = m_{eff} \frac{dV}{dt} \quad (3)$$

$$V(t) = \frac{1}{m_{eff}} \int_0^t (\sum F) dt \quad (4)$$

The GEM model uses an “effective mass” formulation that includes powertrain inertial effects. In the GEM code, the vehicle static mass (vehicle.chsmass_static) is added to the representative powertrain inertial mass (tire_mass_out). For steady speed vehicle operation the powertrain inertial mass should be zero. Figure 2 shows the vehicle inertial mass (tire_mass_out) for the constant desired vehicle speed period of the 55 mph drive cycle. The inertial mass of 1693 kg during the steady speed demand region represents 5% of the static vehicle mass. Figure 2 shows that the inertial mass term is not zero during the constant-desired-speed portion of the drive cycle. Figure 3 shows the vehicle chassis speed varies during the constant speed period of the 65 mph drive cycle.

The 3% discrepancy between analytical and GEM simulated torque may be due to the speed variation during this portion of the drive cycle. The consistency of the model vehicle dynamics with actual vehicle dynamics is a possible way to assess

whether the model is representative of actual vehicle dynamics. Figure 4 shows engine torque during the acceleration ramp leading up to the 55 mph steady speed demand region of operation. Comparing actual engine torque response to this dynamic torque response would be a way of assessing whether the dynamics are reasonable or not. The quality of these response dynamics will be even more critical for transient drive cycle analysis.

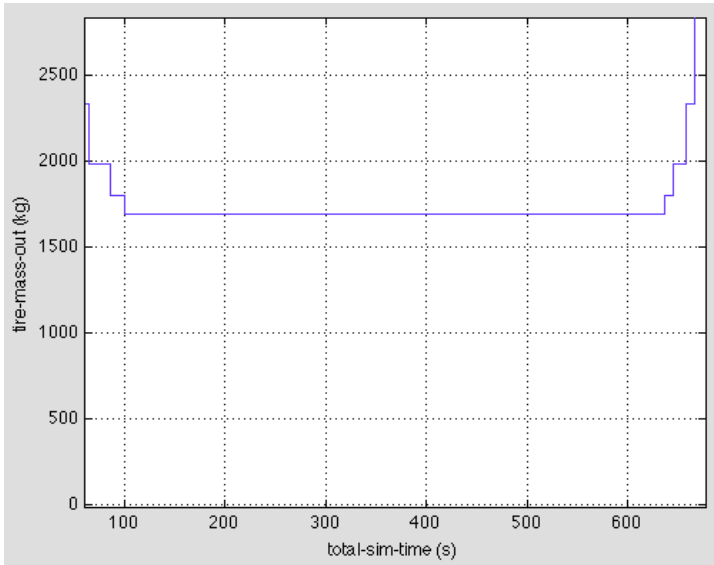

Figure 2 - Inertial mass during the constant speed demand portion of the 55 mph drive cycle.

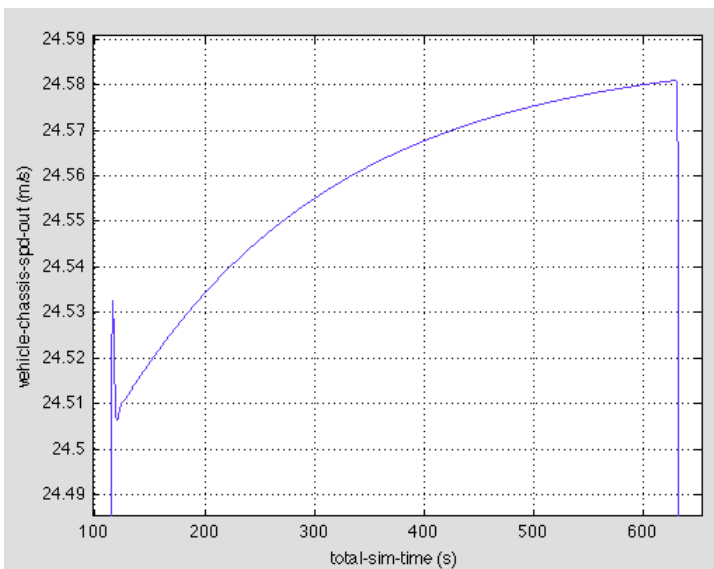

Figure 3 - Actual vehicle chassis speed during the constant speed demand portion of the 55 mph drive cycle.

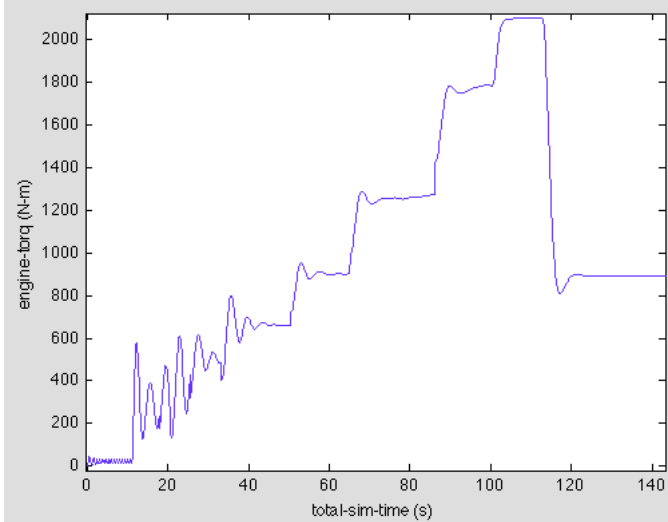

Figure 4 - Engine torque during acceleration ramp in 55 mph drive cycle.

The next sanity check is whether the fuel consumption and GHG emissions are correctly calculated based on the engine torque and speed. Figure 5 shows the torque versus engine speed contour map. Table 2 shows a comparison of off-line calculations of the output parameters from the 55 mph and 65 mph cases in table 1 to the output from the GEM simulation code. The torque and speed used for these calculations are the torque and speed calculated by the GEM simulation code, not analytically calculated torque and speed from table 1. Very small error (less than 0.3%) between off-line and GEM simulation calculations is seen. These differences could be attributed to round off or the averaging used for off-line calculations.

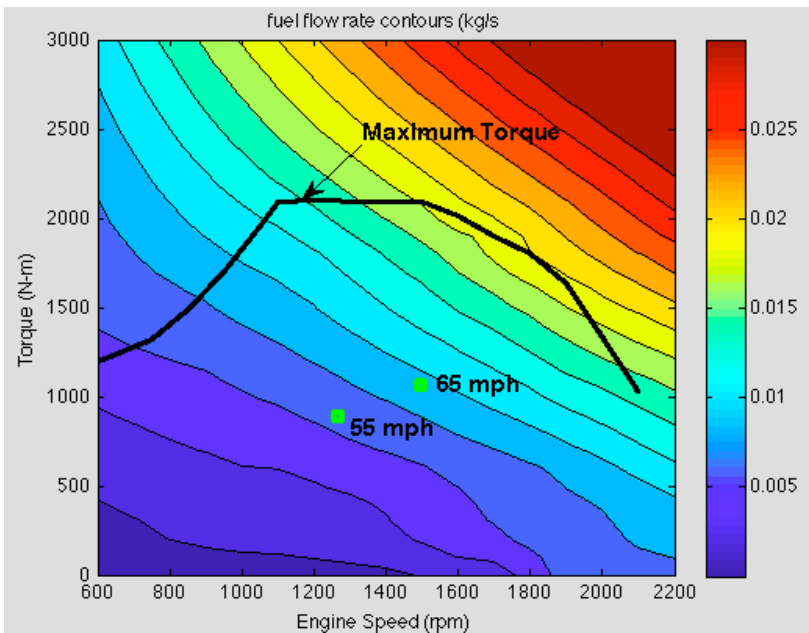

Figure 5 - contours of fuel flow rate versus engine speed and torque for 15L engine from "engine_map_455.m".

Table 2 - Comparison of GEM simulation and direct interpolation of fuel flow for 55 mph and 65 mph cases in Table 1. Comparisons are for “veh_type(i_sim) = 1” “Class 8 Combination - Sleeper Cab - High Roof.” The engine is the first map “veh_year=1.”

Property	Units	55 mph	65 mph	Source
Engine speed	Rpm	1266.5	1495.6	GEM simulation
Engine torque	N-m	892.5	1066.2	GEM simulation
Fuel flow rate	kg/s	0.00660	0.00932	GEM simulation
Fuel flow rate	kg/s	0.00661	0.00934	Interpolated from map in engine_map_455.m
Difference in calculated versus GEM simulated fuel flow	%	0.2	0.2	Calculated
Fuel density	kg/L	0.847	0.847	From “engine.cyl.fuel_desity” in engine_map_455.m
Volumetric fuel flow rate	L/s	0.00780	0.0110	Calculated
Volumetric fuel flow rate	gal/hr	7.417	10.5	Calculated
Vehicle speed	miles/hr	55	65	Desired steady state speed from drive cycle
Fuel consumption	miles/gal	7.42	6.21	Calculated
Fuel consumption	miles/gal	7.40	6.19	GEM simulation results
Difference in calculated versus GEM simulated fuel consumption	%	0.2	0.3	Calculated
Payload	Ton	19	19	From run_preproc.m
CO2 to ton-mile conversion	g CO2/ (mpg* payload)	10180	10180	From run_preproc.m
CO2 emissions	g/(ton-mile)	72.21	86.56	Calculated
CO2 emissions	g/(ton-mile)	72.38	86.52	GEM simulation results
Difference in calculated versus GEM simulated CO2 emission		0.2	0.05	Calculated

Following up on the earlier discussion of engine and vehicle integration, Table 3 shows an example of the effect of engine sizing on overall vehicle performance when drag reductions are implemented. The comparison is again for the “Class 8 – Sleeper Cab – High Roof” vehicle used for the calculations in Tables 1 and 2. Three cases are shown: 1) base case with drag coefficient of 0.69 and engine_map_455.m veh_year=1 engine, 2) base case with drag coefficient reduced to 0.60, and 3) base case with drag coefficient reduced to 0.60, and engine downsized to 90% of original engine. As an approximation of downsizing, the engine map, torque, and maximum torque are scaled by a factor of 0.9. This scaling is representative of the performance changes that could be achieved by, for example, reducing the displacement of the engine, or changing the turbocharger parameters.

The results in Table 3 show that a generic engine has limitations demonstrating benefits of drag reduction strategies. The vehicle with reduced drag and reduced engine size has lower fuel consumption and lower CO2 emissions than the vehicle with just reduced drag coefficient. With a generic engine, this model would give a manufacturer that reduces vehicle drag without consideration of vehicle, engine and powertrain integration the same performance as a manufacturer that does further optimization of the vehicle. This example is a very simplistic reduction. With further effort greater performance benefits are likely to be realized.

Table 3 - Comparison of reduction of fuel consumption and CO2 emissions due to drag coefficient reductions and engine-vehicle integration. Comparisons are for “veh_type(i_sim)=1” “Class 8 Combination - Sleeper Cab - High Roof.” The engine is the first map “veh_year=1” in engine_map_455.m. Calculated values come from the GEM simulation code.

Property	Units	Base case	Reduced drag	Reduced drag, reduced engine size
Drag coefficient	no units	0.69	0.6	0.6
Engine scaling	no units	1	1	0.9
Steer wheels coefficient of rolling resistance	no units	0.0078	0.0078	0.0078
Drive wheels coefficient of rolling resistance	no units	0.0082	0.0082	0.0082
Fuel consumption, transient	Mpg	3.51	3.53	3.64
Fuel consumption, 55 mpg steady	Mpg	7.40	7.80	7.96
Fuel consumption, 65 mpg steady	Mpg	6.19	6.66	6.70
Fuel consumption, cycle weighted	Mpg	6.17	6.60	6.66
Improvement in cycle weighted fuel consumption relative to base case	%	0.00	6.97	7.94
CO2 emissions, transient	g/ton-mile	152.47	151.67	147.15
CO2 emissions, 55 mpg steady	g/ton-mile	72.38	68.65	67.27
CO2 emissions, 65 mpg steady	g/ton-mile	86.52	80.48	69.92
CO2 emissions, cycle weighted	g/ton-mile	88.55	82.98	82.15
Improvement in cycle weighted CO2 relative to base case	%	0.00	6.29	7.23

Item 3) Program execution

The objective of this section is to evaluate if by “Using the standard of good engineering judgment, the program execution is optimized by the chosen methodologies.” I interpret this to be asking about the performance of the code as an effective and efficient tool for this application.

The code overall seems to be developed in a way that provides detail on the vehicle and powertrain dynamics. The model, like the vehicle it simulates, is a complex and highly interconnected system. There are many submodels in this code, and there are many imbedded assumptions that are not directly apparent without a great deal of reverse engineering. It is often difficult to test and verify submodels in isolation because they are highly interconnected with the main model and significant effort would be required to recreate inputs suitable for the submodel to run on its own. A general rule in modeling is that the level of complexity of the model should be the minimum level needed to answer the question posed.

The documentation available on the model does not provide a detailed description of the physical models implemented. This kind of detailed documentation is needed to fully understand the model and modeling assumptions involved.

Transparency in the details of the model is important for a regulatory application. Transparency of this model may suffer without detailed supporting documentation on the physics and engineering assumptions underlying each model and submodel.

Item 4) Clarity, completeness and accuracy of output

The model output is overall clear and complete. The model reports the individual drive-cycle results and weighted average results, which is what is most important to the end user. All the inputs needed to reproduce the results are reported. I would suggest that the a code version also be included, so if the code is changed in the future it will be clear from which version an output file evolved.

Accuracy of the results is difficult to assess, since that requires specific comparison to experimental data to evaluate the performance of the model. Based on my testing efforts and experience, the results seem of reasonable magnitude for these kinds of vehicles.

Item 5) Recommendations for improvements

Following are small issues I noticed during my review of the code.

- 1) The syntax in the m-files is not compatible with unix, specifically the directory backslash “\” vs forward slash “/”.
- 2) The windows executable version has predefined values for C_d in a dropdown menu with preset values in increments of 0.02. The C_d value should just be an entry box, like the C_rr values.
- 3) The inputs for weight reduction, speed limiter, and idle reduction are not consistent between the matlab version and the windows executable. For example in the matlab version. In matlab, zero “Weight Reduction” defaults to “N/A,” which causes an error in the windows version. The windows version does accept “N/A” for idle reduction.
- 4) It would be informative to have the fraction of each drive-cycle used in the average reported somewhere in the output.
- 5) The fuel density variable is “engine.cyl.fuel_desity.” For clarity and consistency I would recommend changing this to “engine.cyl.fuel_density.”

Conclusions

- 1) My main concern with the overall approach is the standardization of the vehicle and powertrain combination. This seems to have potential to devalue efforts towards vehicle and powertrain integration and optimization towards GHG reduction.
- 2) The model is quite detailed with regard to powertrain and vehicle dynamics. There is a danger here that imbedded assumptions can effect results in unexpected and undesirable ways. The example of the 3% difference in torque for analytical versus GEM simulation calculated torque for steady state operation may be indicative of these kinds of issues.
- 3) It should be confirmed whether the various controllers in the GEM model are well tuned and result in a vehicle response consistent with empirical data.

- 4) Detailed description of the physics and assumptions imbedded in the models and submodels should be documented and made available to users.
- 5) It may be worth considering if the model could be streamlined to provide greater clarity and transparency while still providing a tool for quantitatively estimating fuel consumption and GHG emissions.

References:

- 1) "Greenhouse Gas Emissions Model (GEM) User Guide," EPA-420-B-10-039, October 2010.
- 2) Jeongwoo Lee, "Vehicle Inertia Impact on Fuel Consumption of Conventional and Hybrid Electric Vehicles Using Acceleration and Coast Driving Strategy," Ph.D. Dissertation, Virginia Polytechnic Institute, 2009, http://scholar.lib.vt.edu/theses/available/etd-09172009-234744/unrestricted/ETD_PhD_Dissertation_Jeongwoo_Lee.pdf
- 3) <http://www.epa.gov/otaq/climate/regulations.htm>
- 4) Uwe Kiencke, Lars Nielsen, "Automotive Control Systems: For Engine, Driveline, and Vehicle," Springer; 2nd edition, 2005.

Appendix: Derivation of vehicle and engine power formulas

Figure a6 shows a free-body diagram of the forces and accelerations on a vehicle. This vehicle has mass m , acting about the center of gravity. Further reading on these derivations is available in the literature [3, 4]. Gravitational acceleration is treated separately here from the vehicle acceleration.

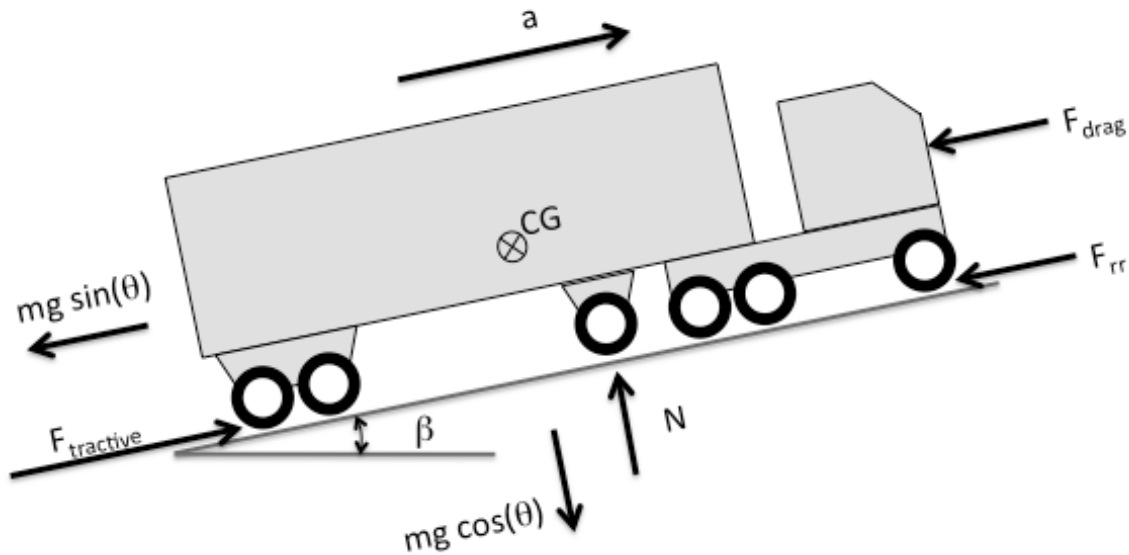

Figure a6 - Free body diagram showing forces and accelerations on a vehicle

The net forces on the vehicle in the direction of movement are:

$$F_{tractive} - F_{rr} - F_{drag} - mg \sin(\theta) = ma \quad (a1)$$

$F_{tractive}$ = required propulsive force on the vehicle

F_{rr} = resistive force due to rolling resistance

F_{drag} = resistive force due to aerodynamic drag

a = net vehicle acceleration in the direction of travel

m = vehicle mass (static vehicle mass)

g = gravitational acceleration

β = angle of vehicle travel relative to gravity normal direction.

The engine transmits torque through the powertrain to the wheels. At the wheels, the torque transferred becomes the propulsive (or tractive) force. Figure a7 shows a schematic of the transfer of torque from engine, through the rotating components of the powertrain, to the force acting on the ground to propel the vehicle.

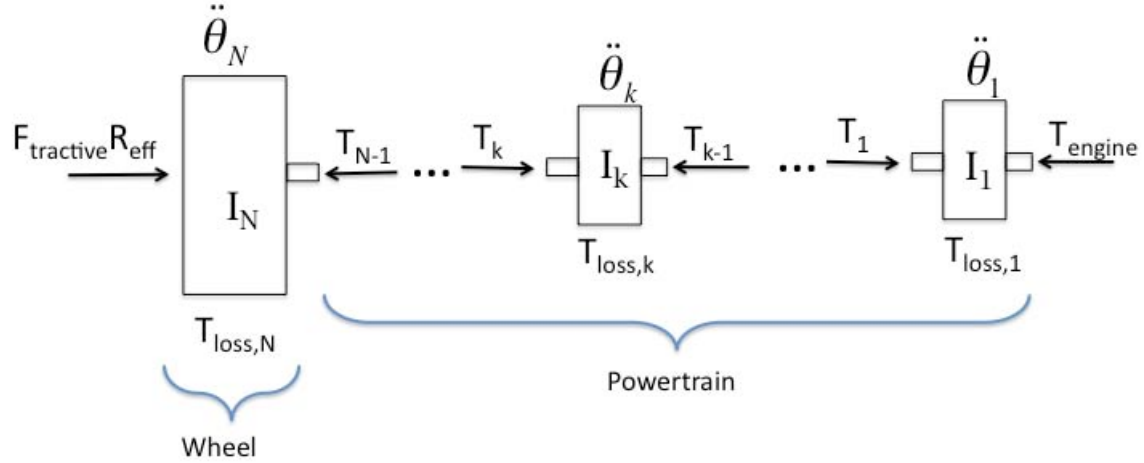

Figure a7 - Torque transfer from the engine, through the powertrain, to the tires.

There are many rotating components in the powertrain, and the engine torque (T_{engine}) is not fully transmitted to the powertrain through frictional loss and due to rotational accelerations. Figure a2 represents the powertrain with N rotational components, each k component having a mass moment of inertia (I_k) and angular acceleration ($\ddot{\theta}_k$). Each component in the powertrain may have frictional losses ($T_{loss,k}$).

$$T_k - T_{k-1} - T_{loss,k} = I_k \ddot{\theta}_k \quad (a2)$$

The tractive force can be calculated from the sum of the moment balance between the engine and all powertrain components, including the wheels. R_{eff} is the effective radius of the wheel over which wheel torque transfers to tractive force.

$$F_{tractive} \cdot R_{eff} = T_{engine} - \sum_{k=1}^N (I_k \ddot{\theta}_k - T_{loss,k}) \quad (a3)$$

The tractive power ($P_{tractive}$) can be determined by calculating the product of torque and angular velocity for every component in the powertrain.

$$P_{tractive} = T_{engine} \dot{\theta}_{engine} - \sum_{k=1}^N (I_k \ddot{\theta}_k \dot{\theta}_k - T_{loss,k} \dot{\theta}_k) = P_{engine} - \sum_{k=1}^N (I_k \ddot{\theta}_k \dot{\theta}_k - T_{loss,k} \dot{\theta}_k) \quad (a4)$$

For convenience, the powertrain power losses are often defined as a transmission efficiency, η_{th} .

$$\sum_{k=1}^N (T_{loss,k} \dot{\theta}_k) = (\eta_{tr} - 1) P_{engine} \quad (a5)$$

The transmission efficiency could be estimated or determined experimentally. Combining equations (a4) and (a5) results in the following equation.

$$P_{tractive} = \eta_{tr} P_{engine} - \sum_{k=1}^N (I_k \ddot{\theta}_k \dot{\theta}_k) \quad (a5)$$

Equation (a1) can also be used to determine power by multiplying the forces by vehicle speed, V .

$$P_{tractive} = F_{rr} V + F_{drag} V + mg \sin(\theta) V + maV \quad (a6)$$

The rolling resistance is defined in terms of a rolling resistance coefficient (c_{rr}) and the normal force of the vehicle ($N=mg \cos(\beta)$).

$$F_{rr} = c_{rr} mg \cos(\beta) \quad (a7)$$

Aerodynamic drag is defined in terms of air density (ρ), drag coefficient (c_d), vehicle frontal area (A_f), and vehicle speed.

$$F_{drag} = \frac{1}{2} \rho c_d A_f V^2 \quad (a8)$$

Combining (a5-a8), vehicle tractive power can be used relate engine power to

$$P_{tractive} = c_{rr} mg \cos(\beta) V + \frac{1}{2} \rho c_d A_f V^3 + mg \sin(\beta) V + maV = \eta_{tr} P_{engine} - \sum_{k=1}^N (I_k \ddot{\theta}_k \dot{\theta}_k) \quad (a9)$$

$$P_{engine} = \frac{1}{\eta_{tr}} \left(c_{rr} mg \cos(\beta) V + \frac{1}{2} \rho c_d A_f V^3 + mg \sin(\beta) V + maV + \sum_{k=1}^N (I_k \ddot{\theta}_k \dot{\theta}_k) \right) \quad (a10)$$

Equation (a10) completely describes the power demand upon an engine due to external forces and powertrain dynamics.

The engine may support vehicle accessory loads (e.g. air conditioning, lights), and these accessory loads will be removed from the engine before the transmission. Since accessory power (P_{acc}) is removed before the transmission, accessory power can be directly added to the engine power demand. Fuel consumption maps are based on gross engine power ($P_{engine,gross}$) or torque and engine speed.

$$P_{engine,gross} = \frac{1}{\eta_{tr}} \left(c_{rr} mg \cos(\beta) V + \frac{1}{2} \rho c_d A_f V^3 + mg \sin(\beta) V + maV + \sum_{k=1}^N (I_k \ddot{\theta}_k \dot{\theta}_k) \right) + P_{acc} \quad (a11)$$

A common practice is to simplify the powertrain inertia characteristics from the final term in equation (a10) to a proportionality scaling of the vehicle acceleration (maV) [ref]. The effective mass (m_{eff}) can be calculated dynamically or approximated.

$$maV + \sum_{k=1}^N (I_k \ddot{\theta}_k \dot{\theta}_k) = m_{eff} aV \quad (a12)$$

Using this effective mass definition gives engine power in terms of five power demand terms: rolling resistance, aerodynamic drag, gravity, acceleration, and accessories.

$$P_{engine,gross} = \frac{1}{\eta_{tr}} \left(c_{rr} mg \cos(\beta) V + \frac{1}{2} \rho c_d A_f V^3 + mg \sin(\beta) V + m_{eff} a V \right) + P_{acc} \quad (a13)$$

PEER REVIEW:

GEM Vehicle Model

Review Conducted for:

U.S. EPA

Review Conducted By:

Shawn Midlam-Mohler

Review Period:

11/19/2010 – 12/12/2010

Contents

Summary.....	4
Introduction.....	5
Objective 1: Capable of modeling a wide array of vehicles over different drive cycles.....	5
Objective 2: Contains open source code, providing transparency in the model.....	5
Objective 3: Freely available and easy to use by any user	6
Objective 4: Contains both optional and preset elements.....	6
Objective 5: Managed by the Agencies for compliance purposes.....	6
Model Structure Evaluation	7
Ambient Subsystem	7
Driver Subsystem.....	7
GEM Manual Misleading	7
Driver PID Values not Configurable	8
Gear Shifting Control.....	8
Electric Subsystem.....	8
Electrical System Parameters not Adjusted with Vehicle Class.....	8
Alternator Model – Current Regulation and Control.....	8
Alternator Model – Accessory Torque	9
Starter Model Complexity.....	10
Pb Battery Model Accuracy.....	10
Pb Battery Model Complexity	11
Electrical Accessories not Adjusted by Vehicle Class	12
Engine Subsystem:.....	12
GEM Manual is Unclear	12
Closed Throttle Engine Torque.....	12

Engine Decel Fuel Cut-Off.....	12
Closed Throttle Engine Fuel Consumption.....	13
Overall Structure of Engine Model.....	13
Mechanical Accessories not Adjusted by Vehicle Class	14
Transmission Subsystem.....	14
Transmission Model Parameters should Change by Class:	14
Vehicle Subsystem.....	14
Vehicle Model Parameters should Change by Class	14
Vehicle Frontal Area.....	14
Vehicle Weight Reduction for Rotating Components:	15
Vehicle Weight Reduction not Implemented for Certain Classes of Vehicle	15
Vehicle Loss Parameters.....	15
GEM Input and Output Files.....	17
Format of Output File (xml)	17
Clarity of Output File.....	17
Content of Output File	17
Standard Input Values Specified in GEM Manual	17
Miscellaneous Comments.....	18
Adjustment of Model Parameters for Different Vehicle Classes.....	18
Model Fidelity.....	18
Sensitivity of Parameters	18
Conclusions.....	20

Summary

The model fidelity of the type proposed should be capable of achieving the desired objectives. The model reviewed, however, has a number of issues which cast doubt upon the specific implementation of the model. Specifically, a number of issues were found in the electrical subsystem as well as the engine subsystem. In many cases, it is felt that the level of modeling used in subsystems, the electrical subsystem being one excellent example, are more complicated than necessary given the relatively low impact on the desired outcome.

From the supporting material, it is clear that the model did an acceptable job at modeling a Class 8 SmartWay truck. Further validation across the range of vehicles being modeled would be appropriate to provide confidence to the end users and ensure the model is doing an acceptable job at modeling green house gas emissions.

It is also recommended that a better understanding of the propagation of uncertainty in the key model input parameters be evaluated. For instance, key parameters like the drag coefficient and coefficient of rolling resistance can be measured with a certain degree of uncertainty. It is possible to determine how these errors propagate through the model and impact the end result of fuel consumption or greenhouse gas emissions. These results should be one part of the overall evaluation of the model. This level of uncertainty should then be compared to the end use of the model and the expected resolution required to distinguish between different technologies.

Introduction

The peer review directives suggested addressing a number of different issues. The first topic was an overall assessment of the model to meet the stated objectives. In the following subsections, there are some high-level comments on the ability of the proposed model to achieve the five attributes listed in the peer review statement.

Objective 1: Capable of modeling a wide array of vehicles over different drive cycles

The model fidelity of the type proposed should be capable of achieving the desired objectives. The model reviewed, however, has a number of issues which cast doubt upon the specific implementation of the model. Specifically, a number of issues were found in the electrical subsystem as well as the engine subsystem. In many cases, it is felt that the level of modeling used in subsystems, the electrical subsystem being one excellent example, are more complicated than necessary given the relatively low impact on the desired outcome.

From the supporting material, it is clear that the model did an acceptable job at modeling a Class 8 SmartWay truck. Further validation across the range of vehicles being modeled would be appropriate to provide confidence to the end users and ensure the model is doing an acceptable job at modeling green house gas emissions.

Objective 2: Contains open source code, providing transparency in the model

Providing source code as a Simulink diagram is necessary for this objective but not sufficient. Additional documentation on the equations and references behind the Simulink code should be developed and released to the public. Even an experienced Simulink user finds it difficult to follow somebody else's code. The code provided is actually laid out quite well but more documentation is necessary to avoid confusion. Inexperienced Simulink users would not be able to follow the code directly and thus would rely much more heavily on the supporting documentation. In later sections there is some critique regarding the current GEM manual in how it describes certain aspects of the model. These issues should be addressed as documentation is refined.

Objective 3: Freely available and easy to use by any user

The compiled version of the code is free and easy to use. The Simulink version requires a Matlab license which is not free but fairly common in industry.

Objective 4: Contains both optional and preset elements

The current structure satisfied this objective.

Objective 5: Managed by the Agencies for compliance purposes

By releasing an official and unalterable executable version of the model this objective is met. Providing only a “source-code” version (*i.e.* Simulink code) would be problematic from many perspectives.

Model Structure Evaluation

The overall approach of using a relatively simple model structure based in Matlab-Simulink is sound provided that models are calibrated and validated to a sufficient level. In the following subsections, there are comments on various issues found in the various sub-models in the model. The following is a summary of what follows:

1. Ambient Subsystem: No issues were found in this very simple subsystem.
2. Driver Subsystem: No major issues were found in this subsystem.
3. Electrical Subsystem: Several serious problems were found in this subsystem. Most notably, there are serious flaws in the battery model, the alternator model, and alternator control.
4. Engine Subsystem: There were problems found in this subsystem which need addressed. The main concerns in this subsystem are from the method use to model the engine at negative brake torque values.
5. Transmission Subsystem: No major issues were found in this very simple subsystem.
6. Vehicle Subsystem: Some issues were found in this subsystem.

Ambient Subsystem

The ambient subsystem contains only parameters to describe the ambient conditions. There were no relevant comments on this subsystem.

Driver Subsystem

The driver subsystem is typical of those found in other models of similar fidelity. There were no major issues found within the Driver Subsystem. The following subsections contain some comments on models or controls within this subsystem.

GEM Manual Misleading

The manual describes that the driver block in a misleading fashion. One sentence in particular: “The search for the proper vehicle speed occurs at every simulation time step.” This seems to imply it is something other than a simple PID control.

Driver PID Values not Configurable

From experience, there are times when the PID gains for a driver may need to be adjusted in order to drive a particular velocity profile. The PID values are fixed in the current model. If an end-user has a vehicle in which the driver does a poor job there is no recourse to correct this. It may be worth adding this as an “advanced feature” or using a more sophisticated control concept. For example, the driving trace is known as are the overall vehicle characteristics for each class, it would not be terribly difficult to augment the current PID control with a feedforward component. This being said, large errors in velocity tracking were never observed in exercising the model.

Gear Shifting Control

The gear shifting strategy was only evaluated by observation. It appears to follow the prescribed shift schedule as desired.

Electric Subsystem

Very significant issues were found in the electric subsystem which require attention. In particular, the battery model appears to an error which causes battery voltage to decrease with battery state of charge which is exactly opposite of the desired behavior. Furthermore, it appears that the sign convention used for the starter, accessories, alternator have the wrong sense. The alternator generates negative current which decreases SOC. The other two currents, which are current sinks, actually increase the SOC of the battery. Even with the above issues aside, the alternator model appears to not consider the mechanical to electrical efficiency of the device and the control is naïve of actual alternator capabilities and control. These issues and others of more minor consequence are described below.

Electrical System Parameters not Adjusted with Vehicle Class

Many of the model parameters used in the electrical system are not changed based on class of vehicle. Many of these would change based on the class of vehicle.

Alternator Model – Current Regulation and Control

The alternator model is particularly difficult to follow from the Simulink code. It appears that alternator current is directly a function of speed, which is not correct for modern alternators

which can regulate voltage quite effectively. Figure 1 shows simulation results for a 45 mph simulation case. This shows a few strange behaviors: 1) the voltage drops to 10 volts by 500 seconds (the vehicle starts moving at 375 sec.); 2) the behavior of the voltage is erratic and not typical of what happen in practice. The second point is a direct result of the control that is applied to the alternator model in that it turns the alternator on at full rated capacity until it reaches a setpoint and then turns it off until voltage drops below a setpoint. This will result in much higher internal I^2R losses than a more appropriate and more realistic model/control that allows the alternator to actually modulate current.

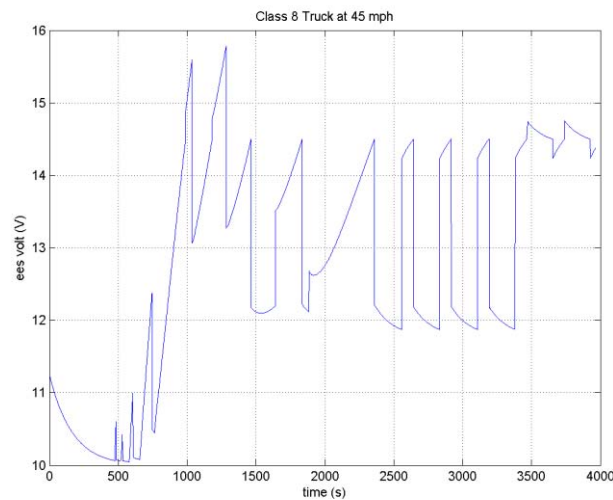

Figure 1: Irregular Voltage of Battery

Alternator Model – Accessory Torque

It appears that the alternator torque is only a function of alternator electrical power demand without accounting for the alternator efficiency. This part of the model is shown in Figure 2. If this is the case then the model is underestimating the accessory torque required to operate the alternator. In looking through the m-file associated with the alternator there was no obvious efficiency parameter for the alternator which further raises doubt.

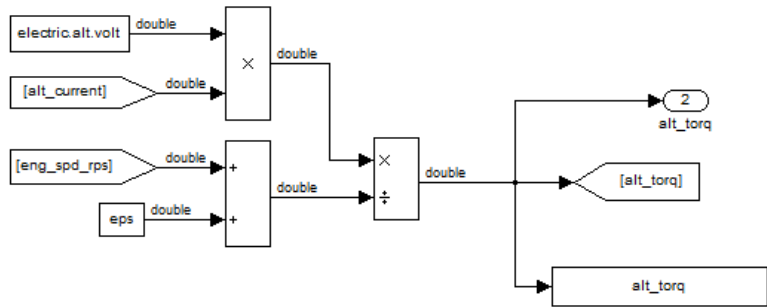

Figure 2: Possible Error in Alternator Mechanical Torque Calculation

Starter Model Complexity

Given the relative unimportance of the starter in the overall performance of the model, the starter model is quite complex. With this level of model, it is clear that parameters should change with the engine class – this is currently not implemented in the model.

Pb Battery Model Accuracy

Investigating the battery model independently led to the discovery of extremely disturbing behavior. With the battery removed and the SOC initialized at zero, a 1-C charge at 352 amps at 20 deg. C was simulated. The battery SOC moved from 0 to 100 in roughly 3600 seconds, which was expected. What was not expected was that the value of “ees_volts” behaves exactly counter to what it would in an actual battery – with increasing SOC the voltage drops very quickly to a minimum value and stays there. The open circuit voltage, which is map based, behaves as expected. Figures showing the results of this test are shown in Figure 3. This behavior was observed in the vehicle simulation as well although it is difficult to observe because of the other dynamics involved.

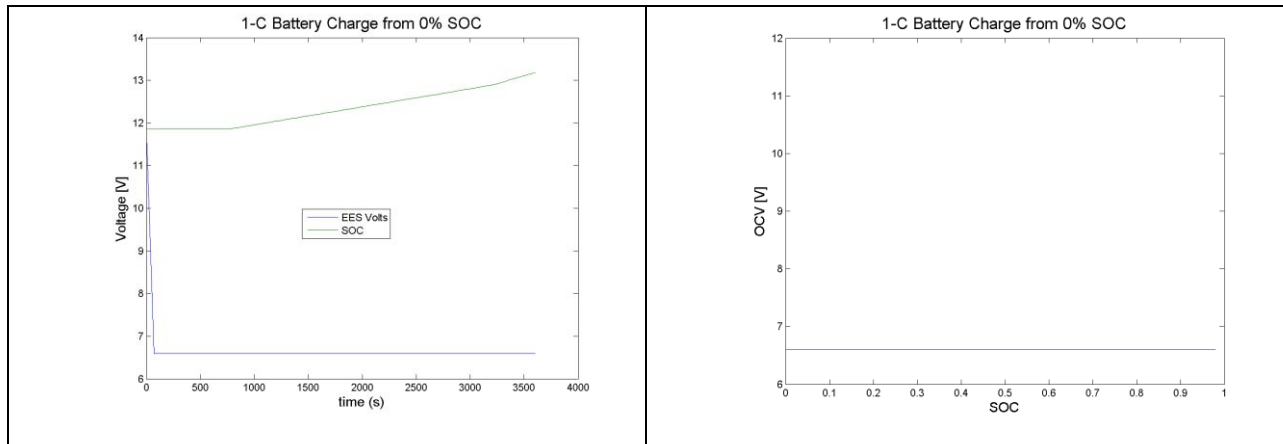

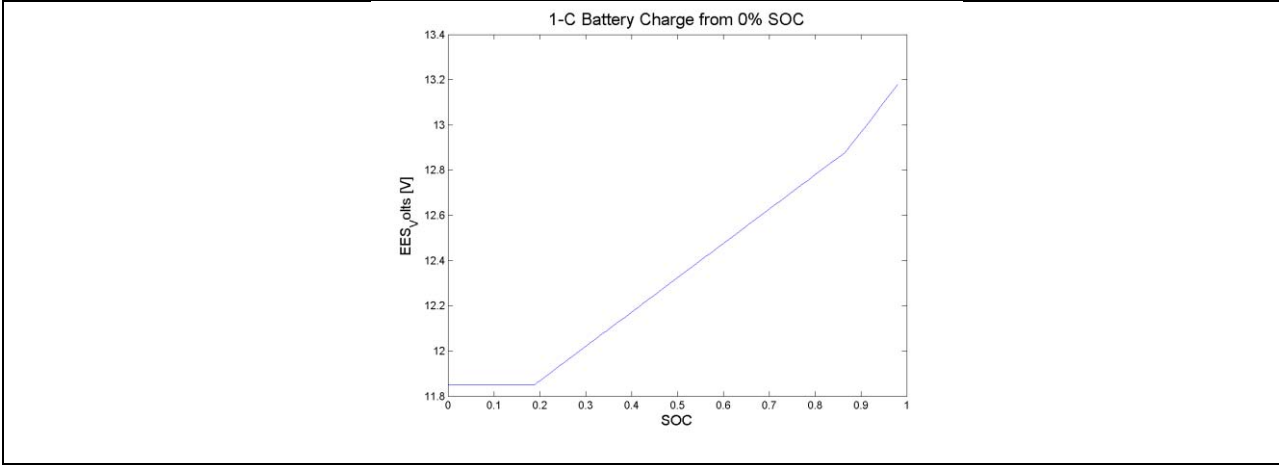

Figure 3: Junction of Three Currents

Further investigation of the electrical system model yielded further inaccuracies. In the model, there is a junction of three different currents: starter, alternator, and accessory current (Figure 4). If one disconnects the alternator current and leaves the starter and accessory current connected (*i.e.* disable the ability to charge the battery) one finds that the battery SOC increases. If one disconnects the loads and applies an alternator current manually (required because of the alternator control and initial SOC) you find the SOC decreases. In both of these cases the “ees_volt” value goes the opposite direction of the SOC.

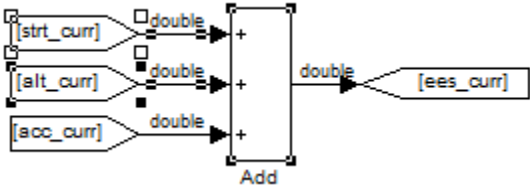

Figure 4: Junction of Three Currents

Pb Battery Model Complexity

The battery appears to be unnecessarily complicated with respect to the objective of the model. In particular, modeling the thermal dynamics of the battery seems excessive. Over the transient cycle for a Class 8 truck, the battery changes temperature by less than one degree. Generally, more complicated models than necessary require more calibration parameters and could be more prone to inaccurate results. This level of complexity seems unnecessary.

Electrical Accessories not Adjusted by Vehicle Class

The electrical accessory load is not adjusted by vehicle class. The electrical accessory loads are not constant between classes.

Engine Subsystem:

The issues found in the engine subsystem are not as serious as those in the electrical subsystem, yet they still need to be addressed. The method of handling negative brake torques in the model does not seem to be appropriate. Because the engine model is one of the most important in the simulator it must be as accurate as possible. Although not a technical flaw, many of the variable names in the model are confusing or irrational, such as “closing throttle torque” and “closed throttle torque” – use of such language leads one to question the model structure and calibration.

GEM Manual is Unclear

The manual’s description of the engine model is misleading. In particular, the sentence “This map is adjusted automatically by taking into account three different driving types: acceleration, braking, and coasting.” This text is not very descriptive of what is actually in the model.

Closed Throttle Engine Torque

Closed “throttle” is an inappropriate way to describe this parameter for a Diesel engine. Diesel engines can have throttles but they are used for purposes other than load control. The values seem to be the identical for each of the engine classes as well as being contrived numbers since it is precisely equal to -5. This would impact the rate of deceleration and potentially have an impact on overall fuel economy predictions.

Engine Decel Fuel Cut-Off

There is no implementation of fuel cut-off during decelerations. This is a feature that is implemented on at least some heavy-duty Diesel engines. This can be observed by plotting the fuel flow rate during the transient cycle.

Closed Throttle Engine Fuel Consumption

The method used to calculate “closed throttle” fuel consumption is not clear. The part of the code which does this is shown in Figure 5. The use of variable such as “closed throttle torque” and “closing throttle torque” do not inspire confidence in the model as they are non-standard terms – particularly for a Diesel engine. It is difficult to understand exactly why this calculation should result in a valid fuel flow.

It is possible in a lab setting to measure fuel consumption from max rated torque down to zero brake torque. With a motoring dyno, it is then possible to measure fuel consumption at negative brake torques until the engine reaches a condition where it injects a minimum amount of fuel, or in many cases, absolutely no fuel. It is understood that not all engines will have these “negative brake torque” fuel maps available, however, there are approximate ways of modeling this, such as techniques based on the popular Willans Line method.

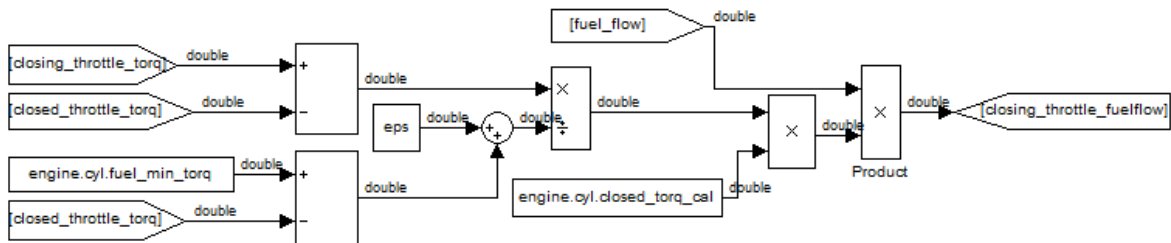

Figure 5: Closed-Throttle Fuel Flow Calculation

Overall Structure of Engine Model

A map-based engine model should be sufficient to achieve the desired objectives. The engine model implemented in the current version of the software does not appear to be as well implemented as it could be. Given the importance of this in the overall objectives of the simulator this needs to be addressed. Using fuel maps which have torque indices ranging from a negative brake torque to the maximum rated torque would alleviate much of the uncertainty in the model. Driver accelerator requests should then be linearly scaled from minimum value to the maximum value on this map with the exception of idle conditions in which alternative measure must be taken. This approach also automatically takes into account deceleration fuel cut-off as well.

Mechanical Accessories not Adjusted by Vehicle Class

The mechanical accessory load is not adjusted by vehicle class. The mechanical accessory loads are not constant between classes.

Transmission Subsystem

There were no serious model issues found in this subsystem. As with many other subsystems, there are a number of parameters which should change with vehicle class.

Transmission Model Parameters should Change by Class:

There are many transmission parameters which currently do not depend on vehicle class, such as clutch and gear inertias. In vehicles which across this range of classes the inertias are likely much different. These parameters can be found in “transmission_manual_param.m”.

Vehicle Subsystem

There were no modeling errors noted in the vehicle subsystem, however, there are a number of things which could be taken as recommendation. The most serious item is considered to be the fact that the “Vehicle Weight Reduction” parameter is specifically cited as being able to model light-weight wheels. The existing model structure would not accurately do this as it does not take into account the inertial aspect of the wheels which would have a greater impact on the vehicle.

Vehicle Model Parameters should Change by Class

There are many vehicle model parameters which currently do not change with vehicle class and should. There are a number of driveline component inertias which do not appear to change with vehicle class. These parameters can be found in “vehicle_param.m”.

Vehicle Frontal Area

The impact of tractor cab design is one of the key technologies that this simulation is intended to evaluate. The equations used to model drag is the typical $0.5 * C_d * A * \text{velocity}^2$. The proposed approach constrains the frontal area (A) to fixed values that depend on vehicle class. This could dis-incentivize novel cab designs which result in smaller frontal areas for a

given class of vehicle. It is recommended that allowing the frontal area be an input parameter to the model. In certain disciplines it is common to parameterize a model using a lumped $Cd \cdot A$ term because of their interrelation.

Vehicle Weight Reduction for Rotating Components:

The “Vehicle Weight Reduction” parameter is described as a way to accommodate, among other things, lighter weight wheels. Simply subtracting wheel weight from payload will underestimate the impact that light-weight wheels will have on the vehicle because it neglects the rotating inertia of the wheels. This could be accommodated given information on the rotating inertia of the wheels and subtracting it from the appropriate tire inertias in the mode – this would be in addition to the weight reduction already implemented.

Vehicle Weight Reduction not Implemented for Certain Classes of Vehicle

The code used to adjust vehicle mass for weight reductions does not do so for many of the vehicle classes. This is shown in Figure 6 below.

```
% Define Vehicle Payload (ton) and Weight Reduction (lb)
% ... in case there is weight reduction
if isempty(weight_reduce) == 0
    % class 8 combination truck
    if veh_type(i_sim) <= 5
        payload(i_sim) = 19 + (weight_reduce(i_sim)*lb2ton)/3;
    % class 7 combination truck
    elseif veh_type(i_sim) == 6 || veh_type(i_sim) == 7
        payload(i_sim) = 12.5 + (weight_reduce(i_sim)*lb2ton)/3;
    % class 8 vocational truck
    elseif veh_type(i_sim) == 8
        payload(i_sim) = 19;
    % class 6-7 vocational truck
    elseif veh_type(i_sim) == 9
        payload(i_sim) = 5.6;
    % class 2b-5 vocational truck
    elseif veh_type(i_sim) == 10
        payload(i_sim) = 2.85;
    end
end
```

Figure 6: Vehicle Weight Reduction Code from run_preproc.m

Vehicle Loss Parameters

The vehicle loss parameters used, mainly rolling resistance and drag coefficient, use very basic models. Essentially, the rolling losses are characterized entirely by a single constant per tire and a single drag coefficient is used to model the aerodynamic losses. Relying on a single

parameter may not be sufficient to model these losses accurately. An alternative would be to allow alternative forms of entering this data. It is understood that these standards are being under development – but it is certainly possible that these parameters are not well modeled by a constant.

GEM Input and Output Files

The directions provided for the peer review requested some specific information regarding the input and output of the mode. The following subsections address these issues.

Format of Output File (xml)

The .xml format used in the output file will be problematic for some users. Most operating systems opt to open .xml files with programs (MS Word, internet browsers) which do not meaningfully display the results. The manual states clearly that MS Excel should be used to open the file, however, certain users may not heed this warning. It may be beneficial to remind the user from the software after they click the “RUN” button on the compiled code.

Clarity of Output File

The formatting of the output file was clear. The four tab format with the first tab being summary data and others being cycle data was sufficient.

Content of Output File

End users will likely want to see more detail in the output file than just the vehicle target speed and achieved speed. Making a limited number of “internal” parameters available to allow end users a glimpse inside the model without having to use Matlab-Simulink would be sufficient. These should be limited to things relevant to their inputs, such as aerodynamic drag over the cycle, rolling losses over the cycle, *etc.*

Standard Input Values Specified in GEM Manual

It was requested that reviewers comment the proposed standard parameters for the different vehicle classes shown in the GEM manual. Unfortunately, the reviewer does not have the required expertise to make an assessment of the proposed values.

Miscellaneous Comments

The following subsections contain observations which did not fit into the previous sections.

Adjustment of Model Parameters for Different Vehicle Classes

A number of parameters were noted which should change with respect to the vehicle class. The reviewer is certain that there are others that were not noted in this review. It is recommended that the EPA investigate this and take an appropriate action. In many cases, these components will not have a serious impact on the overall performance of the vehicle. By way of example, many of the inertias simulated in the model will not have a large impact on the results in contrast to the large inertia of the vehicle. If this is the case, then these inertias could be discarded from the model with little impact on performance. If the detailed inertias remain in the model, then they should accurately reflect the vehicle class.

Model Fidelity

One overall comment is that there is a higher than necessary level of fidelity in many of the models. By way of example, the battery model is particularly complicated and contributes very little to the outcome of the simulation. There are also a great number of relatively small inertias that are modeled, such as the starter motor inertia. These inertias contribute very little to the type of results that are sought after in this simulation.

The added level of detail also comes with an additional practical consideration in that the models require a great deal more parameters to describe the vehicles in each class. By way of example, the starter inertia of a Class 2b truck is much different than a Class 8 truck. If the starter is modeled as a zero inertia element, then it does not need a defined inertia. If there is an inertia parameter, then it should be a representative number even if it does not have a major impact on the simulation. EPA could reduce the complexity of many of the models with little impact on the accuracy of the simulation – this would then lead to a reduced set of parameters that vary with vehicle class and therefore need to be determined.

Sensitivity of Parameters

It would be useful to have a better understanding the propagation of error in the input parameters. For the proposed configuration for the class 8 high-roof sleeper cab the sensitivity

of the CO₂ result to errors in Cd is approximately 50%. This implies that a 10% error in Cd will result in a 5% error in prediction of CO₂ emissions. For rolling resistance, the impact of a 10% error in the tire rolling resistance causes a 2.3% error in prediction of CO₂ emissions. These sensitivities should be compared to the reduction in CO₂ emissions required as well as the accuracy of the key input parameters in the model. This analysis would also be useful in determining which parameters might be superfluous with respect to the desired output. As discussed above, there are some models which likely have more complexity than necessary.

Conclusions

The overall modeling fidelity and structure of the GEM model should be able meet the objectives of the EPA. There are a number of issues with the current version of the GEM model which would need to be addressed to best meet the objectives. These issues were described in greater detail above, but in summary fit mainly into the following major points:

1. Accuracy of Sub-Models Structure: A number of errors were found in models within GEM. None of these errors are expected to contribute to larger errors to the output results but should be corrected nonetheless.
2. Parameter values for Different Vehicle Classes: Throughout many of the subsystems there are a number of minor parameters which should be changed with vehicle class. Philosophically, if the model has a parameter that should change with vehicle class then it should change with class. If it is determined that changing the parameter with vehicle class has not significant impact on the model results then that parameter should be considered for elimination.
3. Model Complexity: Several of the sub-models had complexity that far outweighed their impact on the results. The battery was one such sub-model which also contained some serious errors in its formulation. Many of these models could be simplified which will also reduce the number of parameters required which impacts the comment in (2) above.
4. Sensitivity Analysis: A rigorous study of the sensitivity of key input parameters should be conducted. Our ability to measure and estimate input parameters is not perfect, hence, the output of the model is affected by this uncertainty. If our ability to measure the coefficient of drag is +/- x.y % then that has an impact on the model output. This uncertainty can then be compared to required accuracy to make a judgment on the validity of this method at estimating green house gas emissions or fuel economy.
5. Model Validation at other Classes: Based on the issues noted in (2) above, it is important to validate the model across vehicle classes. Because the model structure is relatively low-fidelity it has a greater burden of proof when “extrapolating” results. To have confidence in the model some further level of validation should be conducted.

EPA GEM Peer Review

*Elliott Ortiz-Soto
PhD Pre-Candidate
Mechanical Engineering
University of Michigan – Ann Arbor*

The following document reviews the Greenhouse Gas Emissions Model (GEM) from a user's point of view, as well as providing a more detailed evaluation of the modeling approach and assumptions. The review first addresses the executable version of GEM as a black-box simulation from an end-user standpoint, commenting and suggesting improvements on the overall GUI layout, usability and output. The second part looks into the Matlab/Simulink version of GEM. In this case, I attempt to give a more thorough and detailed evaluation of the code, assumptions and underlying physical models. The review is organized as a bulleted list, and it does not follow a particular order, although I did try to arrange the comments by similar subjects. I hope this review provides some useful feedback in the development and improvement of the GEM compliance simulation tool.

GEM Executable and Output

This section provides general feedback on the GEM executable and its output.

- The location of the “Vehicle Model Year” dropdown menu is not intuitive. This is one of the most important parameters of the simulation and it is part of the inputs that affects the results, but it has been grouped with the identification parameters. These should be separated as they currently are, but somehow the “Vehicle Model Year” was left in the top section.
- Having radial buttons with all of the vehicle configurations in the “Regulatory Class” section is not necessary. It occupies space and reduces the GUI's flexibility to add other parameters in the future. This type of list is probably better addressed through the use of a drop down menu. It would reduce the profile of this parameter list, and it would show much more clearly what vehicle type is being used. Currently, closer attention has to be paid to the GUI to notice which radio button of the ten available is selected, whereas with the dropdown menu it is only necessary to read what is displayed.
- On the other hand, it is not clear why there should be a dropdown menu for the “Coefficient of Aerodynamic Drag” parameter. Furthermore, the dropdown menu allows the values to be overwritten by the user, so the dropdown menu has no real purpose. Typically dropdown menus are used to provide the user with a set of fixed options, which are usually not numerical values. A better approach would be to just provide a sample value in the parameter name to give the user an idea of what would be an expected input in the box.

Basically, it should look something like the “Steer Tire RR” and “Drive Tire RR” input boxes.

- The same issue is seen in the “Speed Limiter” input box. There is no real reason why there has to be another dropdown menu. If there are minimum and maximum values for the speed limiter, this should simply be stated either in the GUI or in the documentation, and just allow the user to input whatever integer value they require within these limits.
- A similar observation can be made regarding the “Extended Idle Reduction” parameter. According to the documentation, this parameter is an on/off option. Providing another dropdown menu, which can also be overwritten, is simply confusing. This gives the impression that any number of values, maybe between 0 and 5, can be used as inputs, which I am not sure is the case here. A checkbox object should be used for this type of on/off parameter.
- It appears that some options are only available when a certain “Regulatory Class” is selected, such as the “Vehicle Speed Limiter”, “Vehicle Weight Reduction” and “Extended Idle Reduction”. But from the GUI, it is not clear which ones can be selected with the various vehicle types. It is generally useful to gray-out the options that are not available in relation to another parameter. For example, if one of the vocational vehicles is selected as the Regulatory Class, the three options mentioned above should be grayed-out, letting the user know unambiguously that these are not available with this vehicle class. Currently, it is not clear whether the code is robust enough so that these options are not applied when a certain vehicle is selected, or if you would just obtain incorrect results if these were to be selected unknowingly.
- One significant drawback I found relates to the output file naming scheme. First of all, naming the files based on date and time is not very useful or descriptive. When multiple simulations are performed, it becomes difficult to determine what file you should be looking into, unless you actually open it. The file names should include at least some sort of indication of what the simulation configuration was. The second problem I found was the lack of flexibility to specify where these output files are saved. There should be an option allowing the user to browse and select the main directory where these files are to be saved. As a final comment on this, there is really no reason for each of these files to be saved to a different folder if there is just a single output file. This simply adds an unnecessary layer to the file structure. If multiple outputs were generated, then it would make some sense, but currently, there is a single xml file within a folder with the exact same name.
- When the simulations are run, a series of plots with the drive-cycle profiles are generated. It is not very practical to have to close each of these in order for the next one to show. These should either be generated in different windows or, preferably, in a single tabbed window with all three plots. It should also not be necessary to close the plots for another simulation

to begin. This way, various simulations could be performed and the users could clearly see how the parameters varied affect the vehicle behavior without having to create the plots themselves. A small table with some drive-cycle output, such as the one given in the xml files, would also be useful to see together with these plots.

- Within the output file, there are three sheets with the drive-cycle traces. Plots should be automatically generated because the explicit profile is not of much use unless it is plotted.
- Miles per gallon (MPG) is generally assumed to be a measure of fuel economy, not fuel consumption. Although this is a small detail, it might be worth revising to be consistent with the industry standard. Adding the fuel consumption equivalent in gallons/ hp-hr (liters/hp-hr) or liters/100 km might also be useful.
- For compliance purposes, it would be good to see the actual target value next to the simulation result, and probably some sort of percentage difference between these. It would give the manufacturer/user an idea of how their product performs with respect to the expected regulation standard.
- Although the idea of the current program is to reduce complexity and provide only the necessary information for compliance purposes, some additional results might be helpful for manufacturers to determine if the simulation is representative of their vehicle. Because many model parameters and vehicle operating strategies have been standardized using internal assumptions and algorithms, the overall behavior of the vehicle in question could end up being very different from what the vehicle manufacturer actually observes. This can result in a significant over-estimation of fuel consumption and CO₂ emissions, and possibly non-compliance. For this reason, it is fair that the manufacturer be able to assess the validity of the simulation without having to investigate the model in detail. This could be achieved by providing a series of additional results, which could be related to the engine operation over the drive-cycles, the shifting strategy, the electrical system, etc. Exactly what parameters these should be might not be so simple to determine, but it could provide some confidence in the simulation results.

Matlab/Simulink GEM Model

This section provides an evaluation of the GEM Matlab/Simulink model and simulation.

- General comments on the GUI and Matlab simulation:
 - The internal names (tags) for the objects (buttons, dropdown menus, etc.) in the Matlab GUI script should be more explicitly named for clarity and understanding of the GUI functionality.
 - Default parameters should be assigned in the GUI opening function so the user has a better idea of what to select or provide as input.

- The date is not automatically imported as in the executable, and the simulation crashes if the user forgets to write it in.
- If the model is run with any of the Stateflow blocks open, it increases the simulation time substantially.
- In general, the Simulink model is well organized and intuitive. The use of the following modeling techniques and Simulink components make the model particularly elegant and easy to understand:
 - Multiple “Bus” elements and collecting them into a “System Bus” to keep signals clearly labeled and organized.
 - “GoTo” tags to avoid excessive model clutter with connections between blocks.
 - Stateflow instead of explicit Simulink logic blocks, which greatly simplifies development and implementation of the various logic controllers.
 - Signal-activated blocks to avoid additional logic blocks for signal generation and routing.
- Even though the use of various “mux” and “demux” components, as well as a series of component Buses and an overall System Bus is a very elegant modeling approach, it seems that many of the signals are also being output separately, which somehow defeats the purpose of having a Bus. I am sure there is some reasoning behind this, but I would have expected this Bus component to be used more widely, routing the signals directly to/from the Bus everywhere they are required.
- Some blocks go into deeper levels unnecessarily. Examples can be found in the electrical system and in the driver models. Although the approach used in this model of grouping models into blocks based on their physical components or functionality is fairly intuitive, adding extra layers can also make the model more difficult to follow if done excessively.
- Is it necessary to have an “Ambient Bus”? The Bus component is used to collect signals calculated in the model, whereas the ambient parameters are all prescribed and fixed. They could just as easily be called as a variable from the workspace wherever they are needed (this seems to be what is typically done in the model anyway).
- In the pre-processing file, where the parameters for the individual configurations are selected, there appears to be a lot of repeated code and “if/else statements”. Most of these parameters can simply be collected in arrays, which can then be indexed using the “veh_type” variable. This way they can be included in the original parameter files, as they are more explicit and easier to read by a user than having to review a long pre-processing script with many conditional statements. It would also take advantage of Matlab’s array operations, which are

usually more efficient than “for loops” or “if statements”, as well as removing a lot of the repeated code. This will most likely result in improved code performance.

- Control for most of the vehicle components seems to be achieved by fairly standard PID controllers. Usually the gains for these controllers are tuned to a specific plant, but in this case they remain fixed for all the vehicle configurations. Were these gains tuned for all the plants individually and then somehow averaged to account for all of them, or were they computed for a single vehicle? Although for the test cases do not show any major problems with following the prescribed velocity profile, simulation of some vehicles or with a different set of parameters could possibly suffer if the controller gains are not appropriate. For the driver, for example, more elaborate, robust and reusable driver models exist, and it might be useful to investigate the possibility of incorporating one of these in order to avoid possible issues with the simulations.
- In a related comment, Simulink offers pre-developed PID blocks in which only the gains must be prescribed. Is there any particular reason why the PID controllers have been explicitly created? It might help reduce the profile of the individual models if these were to be employed.
- The engine speed appears to be calculated within the Accessories block, which is not very intuitive when reviewing the model. I would expect this to be within the main Engine block and then passed to the other engine-related blocks from there.
- In both the Gear and Clutch blocks of the Transmission model, it is assumed that the gears and clutch are either fully engaged, where they pass the total torque being input, or fully disengaged, where they pass zero torque. Although this might be a fair simplification for the given modeling purposes, there are simple models that can calculate the transmitted torque based on the gear/clutch slip or speed differential. This will add a little more complexity to the model, but it should result in more realistic vehicle behavior.
- The electric components and EES seem to be fixed for all the vehicles in the simulation, but in reality the electrical system is probably designed for a given application to account for the particular load requirements. It is understandable that due to the complexity of acquiring parameters such as these, the system model is standardized, but it could also result in simulation inaccuracies. It might be more appropriate to provide at least some basic scaling capability for the overall electrical system so that with one or two additional inputs, the electrical components and EES are scaled to match the actual setup more closely.
- A similar observation can be made regarding the starter and alternator models. Both appear to be parameterized based on HD Class 8 components. Does this mean that these components are oversized when used in smaller vehicle classes? If so, would they not impart a larger load on the engine, or require a larger amount of electrical power to operate when

compared to a right-sized component? These are most likely not critical components of the model due to the drive-cycles being used, but again, a scaling factor, even if it is an internal value, should be applied to ensure these are representative of the actual system in the vehicle.

- There seems to be an internal option for an acceleration test. Will this be made available to manufacturer users? Acceleration tests are in general much simpler to perform than a full transient drive-cycle, so providing this optional capability might give the manufacturers another way of validating the model. If acceleration numbers are completely different, then it would be hard to expect that a transient drive-cycle simulation would be at all representative of the real vehicle.
- One of the most important input data for a fuel economy drive-cycle simulation is the engine mechanical load and fuel consumption maps. The mechanical load maps are usually simple because only the WOT (or Diesel equivalent) values are required, but obtaining full range fuel consumption values is much more difficult. Several engine maps appear to be available for each vehicle class, but making these completely standard with a prescribed displacement volume and operating range might be a limiting factor for some manufacturers. A more flexible approach would be to have normalized load and fuel consumption maps, given in BMEP and BSFC values. The current maps can be easily converted into BMEP and BSFC with the data available. The user could then provide the engine displacement and possibly another key parameter such as rated torque or power and the engine speed, and an algorithm could automatically manipulate the normalized maps to obtain more representative absolute values for the engine in question. Even though this compliance tool assumes that the engines have already been certified, the fuel economy and CO₂ values that the simulation predicts are directly related to the maps given, and manufacturers might want to ensure the engines in their vehicles are properly accounted for.
- The closed throttle or motoring torque in all of the engine maps is -5 N-m, except at the idle speed. This might be a reasonable simplifying assumption, but in general the motoring torque increases with engine speed due to the rise in friction. It might be worth adding some sort of speed dependence to ensure correct engine decelerating behavior during non-fueling conditions.
- The shifting strategy can also be considered a significant factor affecting vehicle behavior in a drive-cycle simulation such as this. Moreover, they tend to be very specific to the combined engine/vehicle configuration, making them hard to obtain from manufacturers or extrapolate from ones currently available. The shifting strategy shown in the transmission parameter file is only a function of vehicle speed, whereas shifting, in general, is load dependent as well. When load is included as a dependency factor, the shifting strategy has to be related directly to specific engine map. Most likely these shifting speeds are for WOT, but at lower loads the strategy tends to be slightly different to maximize fuel economy. In my experience, it is possible to develop reasonable shifting maps optimized for fuel economy

based on a given engine map. This is usually achieved by finding the most efficient engine speed at various engine load intervals, thus creating an optimum engine operating line, which can be related to the vehicle speed through the various gear ratios. The goal of the shifting strategy is then to maintain the engine operating as close to this line as possible. This approach works well for low/mid load operation. For high loads, where acceleration and gradeability are more important, the shifting maps should be corrected, which can be done in this case using the available WOT shifting speed numbers. Internally generated shifting maps would also allow for engine map scaling as mentioned above, without requiring new shifting strategy data.

- As part of the simulation output and the suggestion for some additional data provided to the user, it would be interesting if plots of the engine map and shifting strategy are included. A simple assessment of these could give the user a good idea about the appropriateness of the given modeling assumptions for their vehicle setup being evaluated. As an extension of this, the various drive-cycle visitation points could be plotted on the engine map as well.
- Some models, such as the electrical system, appear to be extremely complex and detailed for this type of dedicated simulation. Unless there is a particular reason, such as future extensions to GEM for hybrid-electric trucks or different drive-cycles, where such details are necessary, then the electrical system model can probably be stripped down substantially without sacrificing much fidelity in the simulation.
- Similarly, the Stateflow engine logic controller contains some states, such as the ones with the engine off, which are probably not seen in any of the simulations, except at the first time step. There is no stop-start functionality or cold-start behavior, so it might not be necessary to have a full starter model and the engine logic could be somewhat simplified. Another related model simplification could be removing the idle controller. A saturation block in Simulink could be used to limit the engine operation to a minimum idling speed without having an additional controller that can end up slowing down the simulation and increasing the complexity of the model.
- There is a block in the engine model called “trans gear shift” whose output does not appear to be actually used anywhere. This block also has a PID controller. It is not clear to me why this block is needed, but if it is not, then it should definitely be removed to prevent the controller from slowing down the simulation unnecessarily when the block is activated.
- In general, the rest of the model looks good. I have looked into the various submodels, in particular for the engine, transmission and vehicle, and they seem to follow the correct approaches. Overall, the model is in great shape and should be a strong starting point for a dedicated simulation oriented to compliance purposes.

EPA's Response to Peer Reviewer Comments

EPA Response to Peer Review

Overall, the reviewers' comments toward the Greenhouse gas Emissions Model (GEM) are positive and constructive, which can be summarized as follows:

- Accuracy of systems (i.e., driver, electric, ambient, engine, vehicle and transmission)
- Parameter sensitivity study related to coefficient of aerodynamic drag (C_d) and coefficient of tire rolling resistance (C_{rr}) to fuel economy or CO_2 emissions
- More model validation
- Model documentation
- Equations, references, etc.

At a component level, it can be further summarized as follows

- Driver model with better feed forward components and more configurable PID (proportional–integral–derivative) gains
- More consistent electric and accessory models
- Environment model with more realistic air density and ambient temperature
- Engine model improvements

Many changes have been made since GEM was first released to the public. One of the key changes is the driver system model. The enhanced system uses a target vehicle driving speed to estimate vehicle torque demand at any given time. Then, the power required to drive the vehicle is derived to estimate the required accelerator and braking pedal positions. If the driver misses the vehicle speed target, a PID controller applies speed correction logic that adjusts accelerator and braking pedal positions for matching targeted vehicle speed at every simulation time step. The driver system, with its feed-forward driver controls, more realistically models driving behavior.

Electric system model is modified to use constant electrical power to simulate vehicle electronics power consumption. The values for electronic and accessory power consumption are modeled as constant over all classes of vehicles. The reason behind modeling power consumption in such a manner is that the certification with use of GEM is done on a relative basis by comparing the new vehicle model result with the pre-selected engine and vehicle result, where all vehicle models use the same electrical and accessory power. The difference in selecting electrical or accessory power consumption is not critical and has no impact on the final certification results. Since GEM is not used to model absolute vehicle emissions, assigning default parameters in the model achieves this objective, even if the absolute emissions may differ from those predicted. In other system-level development, the value for ambient density of air has been changed to represent more realistic conditions, in accordance with standard SAE practices.

All bugs noted by the peer reviewers have been identified and fixed with the exception of the implementation of an algorithm for “deceleration fuel cut-off” during zero throttle deceleration. The agencies recognize that different manufacturers have different fuel cut-off control logics and it would be challenging to implement all control logics without manufacturers providing the data for final model validation. Consequently, we are delaying implementation of a fuel cut-off strategy until a future rulemaking.

In this phase of rulemaking, the agencies have decided to regulate engines and vehicles separately, except for heavy-duty pickups and vans. We believe this separation is the most appropriate way to achieve the near-term reductions without introducing substantial new testing burden on heavy-duty vehicle manufacturers. In the future, though, it may be desirable to certify vehicles and their engines to a complete vehicle standard using a complete chassis test procedure or a more fully-integrated vehicle model to determine emissions levels for combination tractors and some vocational vehicles. At that point, it would be necessary to use fuel maps specific to the engines installed in the vehicles being certified. In this first phase of GHG emission regulation, though, the GEM model uses fixed engine maps to prevent double counting emission reductions from engine improvements (which are subject to compliance with engine standards) and then again in the truck model (to comply with vehicle standards). Further, in direct response to reviewer comments on the GEM engine system, the engine brake torque value at the closed throttle position is no longer negative in the engine fuel map.

As described in the Regulatory Impact Analysis (RIA) Chapter 4, GEM has been validated and benchmarked against test data as well as other well known vehicle simulation tools since GEM was first released to the public. We extended the model validation to both Class 7 and Class 8 vehicles using test data. We also benchmarked GEM’s model prediction against the GT-Drive model which is commonly used in industry.

A sensitive analysis of coefficient of aerodynamic drag (Cd) and coefficient of rolling resistance (Crr) was conducted following the reviewers’ comments. The study shows that the vehicle behavior follows an almost linear relationship between these input parameters and CO₂ emissions. Charts in RIA Chapter 2 show the linear trend of the GEM inputs relative to the CO₂ emissions results. Nonlinearity is fairly weak in the range of variation of those input parameters. Therefore, it is acceptable for the GEM to take as inputs a linear average of fleet Cds and a linear average of tire rolling resistances, or Crr.

The agencies fully recognize the importance of the transmission to overall vehicle performance. However, as noted in the peer review, GEM is not designed to model different transmissions. Likewise, transmission improvements are not part of the technology package on which the GHG emission standard for these vehicles is predicated. GEM’s purpose is to quantify the relative effectiveness of a limited suite of technologies and not to discern the absolute GHG emissions or fuel consumption of whole trucks. As such, the agencies decided to model only those parameters most easily associated with vehicle greenhouse gas emissions reductions. For example, in a sleeper cab combination tractor, parameters identified to be the most significant include Cd, Crr, weight reduction, governed vehicle speed, and extended idle reduction. Transmission improvements could potentially be evaluated as an innovative credit and thus be utilized for demonstrating compliance on that basis.