

Document Header Information

Document Type:	Voucher	Document Name:	VCH20113956
Travel Authorization Number:	101005341	Trip Name:	Nashville & Johnson City, TN / Atlanta & Columbus, GA - Site visits
TA Date:	09/09/20	Currency:	USD
Organization:	VAVACO 101 OFFICE OF THE SECRETARY	Current Status:	CREATED
Purpose:	SITE VISIT	Document Detail:	Nashville & Johnson City, TN / Atlanta & Columbus, GA - Site visits
Type Code:	REGULAR TDY		

Traveler Profile

Name:	WILKIE, ROBERT L	ID:	(b)(6)
TID:	(b)(6)	Organization:	VAVACO 101 OFFICE OF THE SECRETARY
Title:	SECRETARY OF VETERANS	Duty Station:	Washington, DC
Security Cl:		Card:	IBA HLDR NON EXEMPT
Office Address:	810 Vermont Ave NW Washington, DC 20420	EMAIL:	(b)(6)@va.gov
Office Phone:	(b)(6)	Cell Phone:	
Home Address:		Home Phone:	(b)(6)
Alternate Address:		Alternate Phone:	

Document Information

Trip Number:	1			
Purpose:	Nashville & Johnson City, TN / Atlanta & Columbus, GA - Site visits			
Itinerary Locations				
From	To	Itinerary Location	Purpose	Per Diem Rates
09/01/20	09/02/20	NASHVILLE, TN	SITE VISIT	223.00 / 61.00
09/02/20	09/03/20	JOHNSON CITY, TN	SITE VISIT	96.00 / 55.00
09/03/20	09/04/20	ATLANTA, GA	SITE VISIT	157.00 / 66.00

Document Totals

Total Expenses:	1,809.36
Reimbursable Expenses:	770.94
Non-Reimbursable Expenses:	1,038.42
Advance Applied:	.00
Net to Traveler:	119.32
Net to Government:	1,038.42
Pay to Charge Card:	651.62

Document Totals by Expense Category

Expense Category	Cost	Advance Amount
Com. Carrier	1,023.67	.00
Lodging-Per Diem	554.69	.00
M&IE-Per Diem	216.25	.00
Transxn Fees	14.75	.00
Total Expenses:	1,809.36	.00

Trip 1 Details

Expenses					
Trip#: 1	Total Non-Per Diem Expenses:		1,121.61	Total Per Diem Expenses: 687.75	
Date	Description	Category	Cost	Pay Method	Per Diem
09/01/2020	Airline Flight	Com. Carrier	1,023.67	CBA	
09/01/2020	Lodging	Lodging-Per Diem	218.50	IBA	*

09/01/2020	Hotel Taxes	Lodging-Per Diem	35.82	IBA	
09/01/2020	M&IE	M&IE-Per Diem	45.75	OTHER	*
09/01/2020	Government Vehicle	Transportation	.00	OTHER	
09/02/2020	Lodging	Lodging-Per Diem	96.00	IBA	*
09/02/2020	Hotel Taxes	Lodging-Per Diem	15.84	IBA	
09/02/2020	M&IE	M&IE-Per Diem	55.00	OTHER	*
09/03/2020	Lodging	Lodging-Per Diem	157.00	IBA	*
09/03/2020	Hotel Taxes	Lodging-Per Diem	31.53	IBA	
09/03/2020	M&IE	M&IE-Per Diem	66.00	OTHER	*
09/04/2020	M&IE	M&IE-Per Diem	49.50	OTHER	*
09/04/2020	Government Vehicle	Transportation	.00	OTHER	
09/09/2020	TDY Voucher Fee	Transxn Fees	14.75	CBA	

Per Diem Allowances

Trip#: 1 Total Per Diem Allowances: 687.75

Date	Rate	Ldg Cost	Ldg Allowed	M&IE Cost	M&IE Allowed	B L D Conf%
09/01/2020	223.00/ 61.00	218.50	218.50	45.75	45.75	
09/02/2020	96.00/ 55.00	96.00	96.00	55.00	55.00	
09/03/2020	157.00/ 66.00	157.00	157.00	66.00	66.00	
09/04/2020	157.00/ 66.00	0.00	0.00	49.50	49.50	

Advance of Funds

Cannot print default advance form.
Unable to find an other authorization for cash advance.

Account Summary for the Selected Trip

Org: VAVACO 101 OFFICE OF THE SECRETARY	Label: VA VACO 101 OSVA	Acct Code: 000000A0011010004 0142A1101 20/2172	1,809.36
Expense Category: Com. Carrier	Fiscal Year: 2020	Amount: 1,023.67	
Expense Category: Lodging-Per Diem	Fiscal Year: 2020	Amount: 554.69	
Expense Category: M&IE-Per Diem	Fiscal Year: 2020	Amount: 216.25	
Expense Category: Transxn Fees	Fiscal Year: 2020	Amount: 14.75	
Total:			1,809.36

Payment Detail Information

Organization	Label	Accounting String	Payment Method	Amount
VAVACO 101 OFFICE OF THE SECRETARY	VA VACO 101 OSVA	000000A0011010004 0142A1101 20/2172	CBA	1,038.42
VAVACO 101 OFFICE OF THE SECRETARY	VA VACO 101 OSVA	000000A0011010004 0142A1101 20/2172	IBA	554.69
VAVACO 101 OFFICE OF THE SECRETARY	VA VACO 101 OSVA	000000A0011010004 0142A1101 20/2172	OTHER	216.25

Totals by Label

VAVACO 101 OFFICE OF THE SECRETARY VA VACO 101 OSVA Total 000000A0011010004 0142A1101 20/2172 1,809.36

Totals by Payment Method

CBA Total	1,038.42
IBA Total	554.69
OTHER Total	216.25

Attachments

Attachments Exist

Receipt Checklist

Date	Description	Cost
09/01/20	AIR Airline Flight	\$1,023.67
09/01/20	Lodging	\$218.50
09/01/20	Hotel Taxes	\$35.82
09/02/20	Lodging	\$96.00
09/02/20	Hotel Taxes	\$15.84
09/03/20	Lodging	\$157.00
09/03/20	Hotel Taxes	\$31.53

Audits

Audit Name	Result	Reason
------------	--------	--------

Document History 09/09/2020 Voucher: VCH20113956

Copyright 1989-2009 Concur Government Edition: Concur Inc. WILKIE, ROBERT L (b)(6)

STATUS	DATE	TIME	SIGNATURE NAME	REASON
CREATED	09/09/2020	6:10AM EST	(b)(6)	

I certify that the electronic signatures listed above are valid and on file

(b)(6) _____ 09/09/2020

SIGNED DATE

I certify this claim is true and correct to the best of my knowledge and belief, and that payment or credit has not been received by me or the traveler (if signed by alternate representative). I understand there are severe criminal and civil penalties for knowingly submitting a false, fictitious or fraudulent claim (18 U.S.C. Section 287 and 1001, and 31 U.S.C. Section 3729).

Document Signatures

Traveler/Preparer Name: Robert L. Wilkie
Traveler/Preparer Signature: *Robert L. Wilkie*
Date: 9/9/20
Approver Name: _____
Approver Signature: _____
Date: _____

FOR OFFICIAL USE ONLY – DO NOT DISTRIBUTE
FINAL 2

THE HONORABLE ROBERT L. WILKIE
SECRETARY OF VETERANS AFFAIRS
NASHVILLE, TN – MOUNTAIN HOME, TN – ATLANTA, GA – COLUMBUS, GA
TRAVEL ITINERARY
SEPTEMBER 1-4, 2020

TRAVELING PARTY:

The Honorable Robert Wilkie
Michael Meador, Special Assistant to the Secretary
Traci Scott, Senior Advisor for Strategic Communications
Cathy Haverstock, Acting Assistant Secretary for Congressional and Legislative Affairs

(b)(6)

EXECUTIVE PROTECTION:

(b)(6); (b)(7)(C) Special Agent (DL)

(b)(6); (b)(7)(C)

(b)(6); (b)(7)(C) Special Agent (Adv-TN)
Special Agent (Adv-GA)

EVENT / SITE POCs:

Sandra Glover, Chief Communications Officer, VISN 9

(b)(6)

(b)(6) EA to the Medical Center Director, Tennessee Valley HCS

(b)(6) EA to the Medical Center Director, Mountain Home VAMC

(b)(6) Director, Mountain Home National Cemetery

James J. Corbin, Deputy PAO, VISN 7 (GA)

(b)(6) Acting EA-Atlanta VAMC

(b)(6) EA-Atlanta VAMC

Sheila M. Austin, PAO-Columbus VA Clinic

(b)(6) Health System Specialist-Columbus VA Clinic

(b)(6)

SCHEDULING POCs:

Chelsea Childress, Special Assistant, OSVA (Adv-TN)

Albert Guerrero, Special Assistant, OSVA (Adv-GA)

(b)(6) Travel Coordinator, OSVA

(b)(6)

Tuesday, September 1, 2020

Attire: Business

Weather: Washington, DC H-80°; L-71° - Showers
Nashville, TN H-91°; L-76° - Isolated Thunderstorms

1645-1700 ERT / ARRIVE REAGAN NATIONAL AIRPORT (DCA) (15 min)

1 Aviation Circle, Washington, DC 20001

Drive time: 15 min / 4.9 miles

1800 WHEELS UP TO NASHVILLE INTERNATIONAL AIRPORT (BNA)

American Airlines 5163 DCA-BNA 1800-1851, 1 hr 51 min

**FOR OFFICIAL USE ONLY – DO NOT DISTRIBUTE
FINAL 2**

1851 **WHEELS DOWN TO NASHVILLE INTERNATIONAL AIRPORT (BNA)**
1 Terminal Dr., Nashville, TN 37214

1911-1926 **ERT / ARRIVE THE WESTIN NASHVILLE (15 min)**
807 Clark Place, Nashville, TN 37203
Drive time: 15 min / 9.0 miles

RON

Wednesday, September 2, 2020

Attire: Business

Weather:	Nashville, TN	H-87°; L-74° - Isolated Thunderstorms
	Mountain Home, TN	H-87°; L-70° - Partly Cloudy

0748-0800 **ERT / ARRIVE TENNESSEE VALLEY HEALTHCARE SYSTEM (12 min)**
1310 24th Ave S, Nashville, TN 37212
Drive time: 12 min / 2.4 miles

Greeted by:

- Ms. Cynthia Breyfogle, Network Director, VISN 9
- Ms. Jennifer Vedral-Baron, Health System Director, TVHS

0800-0810 **INTRODUCTION TO COVID-19 ENTRANCE SCREENING AREA (10 min)**

Location: TVHS Main Lobby Entrance

Employee COVID-19 Self screening protocol questions attached or use your smart phone and click on link:

<https://www.va.gov/covid19screen> to complete the online screening, or open your camera and hold up phone to QR code.



0810-0855 **LEADERSHIP BRIEFING (45 min)**

Location: Multi-Purpose Conference Room, B-104

Topics:

- COVID 19 Operations
- Community Care
- Mental Health
- Women’s Health
- Challenges
- Opportunities

**FOR OFFICIAL USE ONLY – DO NOT DISTRIBUTE
FINAL 2**

Attendees: (20)

- The Honorable Robert L. Wilkie, Secretary of Veterans Affairs
- Mr. Michael Meador, Special Assistant to the Secretary
- Ms. Traci Scott, Senior Advisor for Strategic Communications
- Ms. Cathy Haverstock, Acting Assistant Secretary for Congressional and Legislative Affairs
- Ms. Chelsea Childress, Special Assistant, OSVA
- (b)(6), Acting Executive Director, VBA
- (b)(6), Assistant Veterans Service Center Manager, VBA
- Ms. Cynthia Breyfogle, Network Director, VISN 9
- Ms. Jennifer Vedral-Baron, Health System Director, TVHS
- Ms. Marianne Myers, Interim Deputy Health System Director, TVHS
- Mr. Ken Turner, Associate Director, TVHS
- Mr. Chris Vadnais, Acting Assistant Director, TVHS
- Dr. John Nadeau, Chief of Staff, TVHS
- Dr. (b)(6) Deputy Chief of Staff, TVHS
- Ms. Cynthia Johnson, Associate Director for Patient Care Services (ADPCS), TVHS
- Ms. Kathleen Nieves, Deputy ADPCS, TVHS
- Sandra Glover, Public Affairs Officer, VISN 9
- (b)(6) Executive Assistant to the Director, TVHS
- Peggy Bloechl, Acting Public Affairs Officer, TVHS
- (b)(6) Public Affairs Specialist, TVHS

0855-0905 COIN RECOGNITION (10 min)

Location: Multi-Purpose Conference Room, B-104

Recipients: (8)

- Mr. (b)(6) Safety Officer
- Ms. (b)(6) RN, Acting Chief Nurse for Medicine
- Mr. (b)(6) Corporal, Police Service
- Dr. (b)(6), Chief of Dental Service
- Mr. (b)(6), Operations and Maintenance Supervisor
- Mr. (b)(6) Decedent Affairs Clerk
- Dr. (b)(6) Deputy Chief of Staff
- Ms. (b)(6) Joint Commission Accreditation Readiness Coordinator

0905-0910 EXECUTIVE TIME (5 min)

**FOR OFFICIAL USE ONLY – DO NOT DISTRIBUTE
FINAL 2**

0910-0940 FACILITY TOUR (45 min)

Tour Led By:

- Ms. Cynthia Breyfogle, Network Director, VISN 9
- Ms. Jennifer Vedral-Baron, Health System Director, TVHS

Highlighted Areas

- 2nd Floor Volunteer Station (b)(6) Chief Experience Officer and Tucker the Service Dog
- Cardiology Clinic – Dr. (b)(6) Chief of Staff
- Transplant Clinic - Dr. (b)(6) Acting Chief of Transplant Service

0940-0955 RECORD VIDEO MESSAGE TO STAFF (15 min)

Location: Executive Suite, Ms. (b)(6) Office, C-104K

Attendees:

- The Honorable Robert L. Wilkie, Secretary of Veterans Affairs
- Ms. Cynthia Breyfogle, Network Director, VISN 9
- Ms. Jennifer Vedral-Baron, Health System Director, TVHS

Support Staff for Video:

- Peggy Bloechl, Acting Public Affairs Officer, TVHS
- (b)(6) Public Affairs Specialist, TVHS
- (b)(6) Public Affairs Specialist, TVHS

0955-1000 MEDIA PREP (5 min)

Location: Executive Suite, Executive Conference Room, C-105

1000-1025 MEDIA AVAILABILITY (25 min)

Location: Front Entrance to TVHS (Canopy in place for inclement weather)

1030-1046 ERT / ARRIVE INTERNATIONAL PLAZA VA CLINIC (16 min)

2 International Plaza, Nashville, TN 37217

Drive time: 16 min / 8.5 miles

Greeted by:

- Ms. Jennifer Vedral-Baron, Health System Director, TVHS
- Dr. (b)(6) Associate Chief of Staff for Ambulatory Care, TVHS
- Mr. (b)(6) Nurse Manager, International Plaza VA Clinic, TVHS

1050-1055 INTRODUCTION TO COVID-19 ENTRANCE SCREENING AREA (5 min)

Location: Suite 300, Digital Screening

**FOR OFFICIAL USE ONLY – DO NOT DISTRIBUTE
FINAL 2**

- 1055-1125 LEADERSHIP BRIEFING / FACILITY TOUR (30 min)**
Tour Led By (b)(6) Nurse Manager, International Plaza VA Clinic, TVHS
Highlighted Areas
- Lobby
 - Whole Health Area
 - Mental Health Group Rooms
 - Primary Care Brief, Dr. (b)(6) Associate Chief of Staff for Ambulatory Care, TVHS
- 1130-1136 ERT / ARRIVE LUNCH (6 min)**
Drive time: 6 min / 2.6 miles
- 1136-1233 LUNCH (57 min)**
- 1233-1238 ERT / ARRIVE NASHVILLE INTERNATIONAL AIRPORT (BNA) (5 min)**
1 Terminal Dr., Nashville, TN 37214
Drive time: 5 min / 3.6 miles
- 1238-1346 EXECUTIVE TIME (1 hr 8 min)**
- 1346-1426 GATE TRANSITION / AIRCRAFT BOARDING (40 min)**
- 1426 WHEELS UP TO TRI-CITIES AIRPORT (TRI)**
American Airlines 4499 BNA-CLT 1426-1700, 1 hr 34 min
Layover at CLT: 1 hr 10 min
American Airlines 4814 CLT-TRI 1810-1912, 1 hr 2 min
Total travel time: 3 hr 46 min
- 1912 WHEELS DOWN TO TRI-CITIES AIRPORT (TRI)**
2525 Highway 75, Blountville, TN 37617
- 1932-1957 ERT / ARRIVE DOUBLETREE BY HILTON JOHNSON CITY (25 min)**
211 Mockingbird Ln., Johnson City, TN 37604
Drive time: 25 min / 13.0 miles
- RON**

**FOR OFFICIAL USE ONLY – DO NOT DISTRIBUTE
FINAL 2**

Thursday, September 3, 2020

Attire: Business

Weather:	Mountain Home, TN	H-87°; L-70° - Partly Cloudy
	Atlanta, GA	H-92°; L-73° - Mostly Sunny

0835-0845 ERT / ARRIVE JAMES H. QUILLEN VA MEDICAL CENTER (10 min)

Corner of Lamont & Veterans Way, Mountain Home, TN 37684

Drive time: 10 min / 2.7 miles

Greeted by:

- Ms. Cynthia Breyfogle, VISN 9 Network Director
- Mr. Dean Borsos, Medical Center Director

0845-0855 INTRODUCTION TO COVID-19 ENTRANCE SCREENING AREA (10 min)

Location: Self Screening

Employee COVID-19 Self screening protocol questions attached or use your smart phone and click on link:

<https://www.va.gov/covid19screen> to complete the online screening, or open your camera and hold up phone to QR code.



If staff have answered **yes** to any of the screening questions, please contact occupational health for additional screening at 423-926-1171 extension (b)(6)

0900-0950 VIRTUAL TOWNHALL WITH SENATOR TILLIS (50 min)

Location: Building 8, Room 212, Director's Conference Room

0950-0955 EXECUTIVE TIME (5 min)

0955-1040 LEADERSHIP BRIEFING (45 min)

Location: Building 8, Room 212, Director's Conference Room

Topics:

- Facility Operational Briefing
- COVID-19 Response
- Western Market Operations

Attendees: (13)

- The Honorable Robert L. Wilkie, Secretary of Veterans Affairs
- Mr. Michael Meador, Special Assistant to the Secretary
- Ms. Traci Scott, Senior Advisor for Strategic Communications
- Ms. Cathy Haverstock, Acting Assistant Secretary for Congressional and Legislative Affairs
- Ms. Chelsea Childress, Special Assistant, OSVA
- Ms. Cynthia Breyfogle, VISN 9 Network Director
- Mr. Dean Borsos, Medical Center Director
- Dr. David Hecht, Chief of Staff
- Ms. Deborah Eddy, Associate Director for Patient Care Services

**FOR OFFICIAL USE ONLY – DO NOT DISTRIBUTE
FINAL 2**

- Dr. Harold Dillon, Chief, Quality Management
- Dr. Angela May, Deputy Chief of Staff
- Ms. (b)(6) Acting Associate Director
- Mr. Paul Windsor, Executive Assistant/Acting Public Affairs Officer

1040-1045 Ui PATH ROBOTIC AUTOMATION DEMO (5 min)

Location: Building 8, Room 212, Director's Conference Room

Presenters (b)(6) & (b)(6)

1045-1055 COIN RECOGNITION (10 min)

Location: Building 8, Room 212, Director's Conference Room

Recipients: (5)

- Mr. (b)(6) Continuous Readiness Coordinator
- Ms. (b)(6) Patient Safety Manager
- Mr. (b)(6) Engineering Service
- Mr. (b)(6) Business Office
- Mr. (b)(6) Logistics Service

1055-1140 FACILITY TOUR (45 min)

*Tour will be conducted via golf cart and Congressman Roe will join SECVA

Tour Led By:

- Ms. Cynthia Breyfogle, VISN 9 Network Director
- Mr. Dean Borsos, Medical Center Director

Highlighted Areas

- COVID-19 Testing Tent (View from the outside)
- Remote Laboratory
- Outpatient Mental Health

1140-1145 MEDIA PREP (5 min)

Location: Building 160, Room 412, Mental Health Suite

1145-1210 MEDIA AVAILABILITY (25 min)

Location: Building 160, Outdoor patio

1215-1220 ERT / ARRIVE MOUNTAIN HOME NATIONAL CEMETERY (5 min)

*Co-located on the Medical Center Campus

215 Heroes Drive, Mountain Home, TN 37684

Drive time: 5 min / .6 miles

Greeted by:

- Mr. (b)(6) Director, Mountain Home National Cemetery

**FOR OFFICIAL USE ONLY – DO NOT DISTRIBUTE
FINAL 2**

1220-1250 CEMETERY TOUR (30 min)

Notable Burials:

- Mr. Walter Preston Brownlow, Tennessee Congressman (*Exit Golf Carts*)
- Sergeant Henry G. Buhrman, Civil War, Medal of Honor Recipient
- Lieutenant Frederick Clarence Buck, Civil War, Medal of Honor Recipient
- Seaman Thomas Smith, Civil War, Medal of Honor Recipient
- Staff Sergeant Junior James Spurrier, World War II, Medal of Honor Recipient

1250-1255 ERT / ARRIVE LUNCH LOCATION (5 min)

Drive time: 5 min / .9 miles

1300-1315 CALL WITH ATLANTA GOVERNOR BRIAN P. KEMP (15 min)

**Call in vehicle - SECVA to call Governor Kemp's Mobile (b)(6)*

POC: Ms. (b)(6) Scheduler Governor Kemp, (b)(6)

1315-1400 LUNCH (45 min)

1400-1430 ERT / ARRIVE TRI-CITIES AIRPORT (TRI) (30 min)

2525 Highway 75, Blountville, TN 37617

Drive time: 30 min / 18.1 miles

1430-1509 EXECUTIVE TIME (39 min)

1509-1549 GATE TRANSITION / AIRCRAFT BOARDING (40 min)

1549 WHEELS UP TO HARTSFIELD-JACKSON ATLANTA INTERNATIONAL AIRPORT (ATL)

Delta Airlines 4839 TRI-ATL 1549-1700, 1 hr 11 min

1700 WHEELS DOWN TO HARTSFIELD-JACKSON ATLANTA INTERNATIONAL AIRPORT (ATL)

6000 N. Terminal Pkwy, Atlanta, GA 30320

1720-1735 ERT / ARRIVE ATLANTA MARRIOTT MARQUIS (15 min)

265 Peachtree Center Ave, Atlanta, GA 30303

Drive Time: 15 min / 12 miles

RON

**FOR OFFICIAL USE ONLY – DO NOT DISTRIBUTE
FINAL 2**

Friday, September 4, 2020

Attire: Business

Weather:	Atlanta, GA	H-92°; L-72° - Sunny
	Washington, DC	H-86°; L-63° - Mostly Sunny

0640-0700 ERT / ARRIVE ATLANTA VA MEDICAL CENTER (20 min)

1670 Clairmont Rd, Decatur, GA 30033

Drive Time: 20 min / 7.8 miles

Greeted By:

- Joe D. Battle, Interim Director, VA Southeast Network
- Ann R. Brown, FACHE, Director, Atlanta VAHCS

0705-0710 INTRODUCTION TO COVID-19 ENTRANCE SCREENING AREA (5 min)

Employee Screening Entrance (Parking Deck E); questionnaire, temp checks, masks required

0715-0725 MESSAGE RECORDING FOR MR. OSCAR GADSON (10 min)

Location: Atrium or TBD

Congratulatory message of 2-3 minutes

0730-0815 LEADERSHIP BRIEFING (45 min)

Location: Director's Conference Room, 3A-207

Topics:

- VBA Overview – Al Bocchicchio, Director, Atlanta Regional Office
- AVAHCS Overview – Executive Leadership Team, Atlanta VAHCS
 - COVID Response
 - Moving Forward Plan
 - Suicide Prevention

Attendees: (15)

- The Honorable Robert L. Wilkie, Secretary of Veterans Affairs
- Mr. Michael Meador, Special Assistant to the Secretary
- Ms. Traci Scott, Senior Advisor for Strategic Communications
- Ms. Cathy Haverstock, Acting Assistant Secretary for Congressional/Legislative Affairs
- Mr. Al Bocchicchio, Veterans Benefit Administration, Director, Atlanta Regional Office
- Mr. Joe D. Battle, Interim Director, VA Southeast Network
- Ms. Ann R. Brown, FACHE, Director, Atlanta VAHCS
- Lance Davis, PharmD, Deputy Director, Atlanta VAHCS
- Ivan Correa, MD, Chief of Staff, Atlanta VAHCS
- Connie Hampton, DNP, Associate Director for Patient Care Services, Atlanta VAHCS
- (b)(6) FACHE, Interim Associate Director, Atlanta VAHCS
- (b)(6) MD, Deputy Chief of Staff, Atlanta VAHCS
- Ms. (b)(6) Deputy Director, OPIA Southeast Region
- Mr. (b)(6) Deputy Director of Communications, VA Southeast Network
- Ms. (b)(6) Acting Executive Assistant to Director, Atlanta VAHCS

**FOR OFFICIAL USE ONLY – DO NOT DISTRIBUTE
FINAL 2**

0820-0830 COIN RECOGNITION (10 min)

Location: Director's Conference Room, 3A-207

Recipients: (5)

- Dr. (b)(6) Chief of Infectious Diseases
- Ms. (b)(6), Nurse Manager, Atlanta VA Clinic and Women's Wellness
- Mr. (b)(6), Procurement Analyst, Supply Chain Management
- Mr. (b)(6) Audiovisual Specialist, Medical Media Service
- Ms. (b)(6), Housekeeping Aide, Environmental Service

0830-0835 EXECUTIVE TIME (5 min)

0835-0920 FACILITY TOUR (45 min)

Tour Led By:

- Ann R. Brown, FACHE, Director, Atlanta VAHCS
- Joe D. Battle, Interim Director, VA Southeast Network
- Ms. (b)(6) Acting Executive Assistant to Director, Atlanta VAHCS

Highlighted Areas:

- Cardiology - Electrophysiology (EP) Lab, Cath Lab (at location – Ivan Correa, MD, Chief of Staff, Atlanta VAHCS)
- Eagles Nest Community Living Center (at location – Lance Davis, PharmD, Deputy Director, Atlanta VAHCS; (b)(6), FACHE, Interim Associate Director, Atlanta VAHCS)
- COVID Operations: Front Screening, Centralized Check-in, Pharmacy – Parking Deck L (at location – Connie Hampton, DNP, Associate Director for Patient Care Services, Atlanta VAHCS)
- COVID Emergency Department, Veterans Learning Center (at location – (b)(6) (b)(6) MD, Deputy Chief of Staff, Atlanta VAHCS)

0920-0925 MEDIA PREP (5 min)

Location: Veterans Learning Center – 1C 460 (private office)

0925-0950 MEDIA AVAILABILITY (25 min)

Location: Outdoor Location

0955-1200 ERT / ARRIVE LUNCH (2 hrs 5 min)

Drive time: 2 hrs 5 min / 115 miles

1200-1210 ORDER LUNCH (10 min)

**Lunch will be a stop during the drive*

**FOR OFFICIAL USE ONLY – DO NOT DISTRIBUTE
FINAL 2**

- 1215-1225 ERT / ARRIVE COLUMBUS VA CLINIC (10 min)**
1310 13th Ave, Columbus, GA 31901
Drive time: 10 min / TBD
Greeted By:
- Joe D. Battle, Interim Director VA Southeast Network (VISN 7)
 - Amir Farooqi, FACHE Interim Director, Central Alabama Veterans Health Care System
- 1225-1230 INTRODUCTION TO COVID-19 ENTRANCE SCREENING AREA (5 min)**
- 1230-1300 LEADERSHIP BRIEFING / FACILITY TOUR (30 min)**
Tour Led By:
- Dr. (b)(6) Chief Medical Officer, Ft. Benning VA Clinic and Columbus CBOC
 - Ms (b)(6) Nurse Manager, Ft. Benning VA Clinic and Columbus CBOC
 - Joe D. Battle, Interim Director VA Southeast Network (VISN 7)
 - Amir Farooqi, FACHE Interim Director, Central Alabama Veterans Health Care System
 - Brian Yee, M,D., Chief of Staff, Central Alabama Veterans Health Care System
- Highlighted Areas:
- Primary Care
 - TeleHealth
 - Women Veterans Health Program
 - Mental Health
- 1300-1305 EXECUTIVE TIME (5 min)**
- 1305-1310 MEDIA PREP (5 min)**
Location: Conference Room
- 1310-1335 PRESS CONFERENCE (25 min)**
Location: Outside Entry Way
- 1340-1515 ERT / ARRIVE ATLANTA HARTSFIELD INTERNATIONAL AIRPORT (1 hr 35 min)**
600 N Terminal Pkwy, Atlanta, GA 30320
Drive Time: 1 hr 35 min / 97.6 miles
- 1515-1547 EXECUTIVE TIME (32 min)**
- 1547-1627 GATE TRANSITION / BOARDING (40 min)**
- 1627 WHEELS UP TO REAGAN NATIONAL AIRPORT (DCA)**
Delta Airlines 1749 ATL-DCA 1627-1815, 1 hr 48 min
- 1815 WHEELS DOWN TO REAGAN NATIONAL AIRPORT (DCA)**

**FOR OFFICIAL USE ONLY – DO NOT DISTRIBUTE
FINAL 2**

1835-1850 **ERT / ARRIVE RESIDENCE** (*15 min*)
Drive time: 15 min / 16.7 miles

MC

4-Sep McD's	\$6.62
2-Sep Hardees	\$9.16
3-Sep Cracker Barrel	\$16.69
3-Sep Ted S Montana grill	\$53.00
1-Sep Popeyes	\$11.46
Total	\$96.93

Westin Nashville
 807 Clark Place
 Nashville, TN 37203
 United States
 Tel: 615-248-2800 Fax: 629-800-5221

THE WESTIN
 NASHVILLE

ROBERT WILKIE

(b)(6)

Page Number : 1 Invoice Nbr : 424282
 Guest Number : 402807
 Folio ID : A
 Arrive Date : 01-SEP-20 13:03
 Depart Date : 02-SEP-20
 No. Of Guest : 1
 Room Number : 1116
 Marriott Bonvoy Number : (b)(6)

Tax ID :

Westin Nashvil BNAWI SEP-02-2020 07:18 (b)(6)

Date	Time	Reference	Description	Charges (USD)	Credits (USD)
01-SEP-20	02:35	RT1116	Room Chrg - Govt./Military	218.50	
01-SEP-20	02:35	RT1116	State Tax	20.21	
01-SEP-20	02:35	RT1116	Occupancy Tax	13.11	
01-SEP-20	02:35	RT1116	City Tax	2.50	
02-SEP-20	04:53	VI	Visa (b)(6)		-254.32
** Total				254.32	-254.32
*** Balance				0.00	

Tell us about your stay. www.westin.com/reviews

Continued on the next page



Duluth Government
 2860 Peachtree Ind. Blvd., Suite 1000
 Duluth, GA 30097
 Phone: (877) 813-5900

Thursday, 20AUG 2020 12:14 PM EDT

Passengers: ROBERT WILKIE (101005341/ 101005341)

Agency Reference Number: 25PALI

Click here to view your current itinerary or ETicket receipt on-line: viewtrip.travelport.com

Do you have your REAL ID to travel? Click HERE for more information.

Enjoy parking discounts from Duluth Travel Inc HERE

AIR	Tuesday, 1SEP 2020		
American Airlines OPERATED BY PSA AIRLINES AS AMERICAN EAGLE From: Washington Reagan Natl DC, USA To: Nashville TN, USA Stops: Nonstop Seats: 18D Equipment: CRJ-700 Canadair Regional Jet DEPARTS DCA TERMINAL C Frequent Flyer Number: <input type="text" value="(b)(6)"/> American Airlines Confirmation number is EDYZNF		Flight Number: 5163 Depart: 6:00 PM Arrive: 6:51 PM Duration: 1 hour(s) 51 minute(s) Status: CONFIRMED	Class: G- Coach/Economy Miles: 552 / 883 KM

HOTEL	Tuesday, 1SEP 2020		
The Westin Nashville (WESTIN) 807 Clark Place Nashville TN US 37203 Number of Rooms: 1 Phone: 16152482800 Rate: USD 218.50 Check Out: Wednesday, 2SEP 2020 Room Type: GOVA00 Guaranteed to: VI***** <input type="text" value="(b)(6)"/> Hotel cancellation policy: CANCEL PERMITTED UP TO 01 DAYS BEFORE ARRIVAL. 254.32 CANCEL FEE PER ROOM.		Confirmation Number: 95854113 Fax: 16298005056 Room GUARANTEED TO VISA Reserved For: WILKIE ROBERT	

AIR	Wednesday, 2SEP 2020		
American Airlines OPERATED BY REPUBLIC AIRWAYS AS AMERICAN EAGLE From: Nashville TN, USA To: Charlotte NC, USA Stops: Nonstop		Flight Number: 4499 Depart: 2:26 PM Arrive: 5:00 PM Duration: 1 hour(s) 34 minute(s)	Class: G- Coach/Economy

Seats: 22D

Status: CONFIRMED

Miles: 329 / 526 KM

Equipment: EMBRAER EMB 175

Frequent Flyer Number: (b)(6)

American Airlines Confirmation number is EDYZNF

AIR	Wednesday, 2SEP 2020	
------------	-----------------------------	-------------------------------------------------------------------------------------

American Airlines

OPERATED BY PIEDMONT AIRLINES AS AMERICAN EAGLE

Flight Number: 4814

Class: G- Coach/Economy

From: Charlotte NC, USA

Depart: 6:10 PM

To: Tri Citites Regional, TN, USA

Arrive: 7:12 PM

Stops: Nonstop

Duration: 1 hour(s) 2 minute(s)

Seats: 17A

Status: CONFIRMED

Miles: 121 / 194 KM

Equipment: ERJ-145 Jet

Frequent Flyer Number: (b)(6)

American Airlines Confirmation number is EDYZNF

HOTEL	Wednesday, 2SEP 2020	
--------------	-----------------------------	-------------------------------------------------------------------------------------

Doubletree By Hilton Johnson C (DOUBLETREE)
211 Mockingbird Lane Johnson City TN 37604

Number of Rooms: 1

Confirmation Number: 93569573

Phone: 1-423-929-2000

Fax: 1-423-929-1783

Rate: USD 96.00

Room GUARANTEED TO VISA

Check Out: Thursday, 3SEP 2020

Reserved For: WILKIE ROBERT

Room Type: A04A78

Guaranteed to: VI***** (b)(6)

Hotel cancellation policy: 48 HR CANCELLATION REQUIRED

Approximate total: TTL-111.84 USD

AIR	Thursday, 3SEP 2020	
------------	----------------------------	---------------------------------------------------------------------------------------

Delta Air Lines

OPERATED BY ENDEAVOR AIR DBA DELTA CONNECTION

Flight Number: 4839

Class: L- Coach/Economy

From: Tri Citites Regional, TN, USA

Depart: 3:49 PM

To: Atlanta GA, USA

Arrive: 5:00 PM

Stops: Nonstop

Duration: 1 hour(s) 11 minute(s)

Seats: 07C

Status: CONFIRMED

Miles: 229 / 366 KM

Equipment: CRJ-Canadair Regional Jet

ARRIVES ATL TERMINAL S

Frequent Flyer Number: (b)(6)

Fare Basis: LCA

Delta Air Lines Confirmation number is HTK2HZ

HOTEL	Thursday, 3SEP 2020	
--------------	----------------------------	---------------------------------------------------------------------------------------

Atlanta Marriott Marquis (MARRIOTT)
265 Peachtree Center AVE Ne Atlanta GA US 30303

Number of Rooms: 1

Confirmation Number: 95356391

Phone: 14045210000

Fax: 14045866128

Rate: USD 157.00

Room GUARANTEED TO VISA

Check Out: Friday, 4SEP 2020

Reserved For: WILKIE ROBERT

Room Type: GOVA00

Guaranteed to: VI*****(b)(6)

Hotel cancellation policy: CANCEL PERMITTED UP TO 01 DAYS BEFORE ARRIVAL. 188.53 CANCEL FEE PER ROOM.

AIR	Friday, 4SEP 2020	
------------	--------------------------	--

Delta Air Lines From: Atlanta GA, USA To: Washington Reagan Natl DC, USA Stops: Nonstop Seats: 16D Equipment: Airbus A321 Jet DEPARTS ATL TERMINAL S - ARRIVES DCA TERMINAL B Frequent Flyer Number: (b)(6) Fare Basis: LCADCA Delta Air Lines Confirmation number is HTK2HZ	Flight Number: 1749 Class: L- Coach/Economy Depart: 4:27 PM Arrive: 6:15 PM Duration: 1 hour(s) 48 minute(s) Status: CONFIRMED Miles: 541 / 866 KM
---------------------------------------------------------------------------------------------------------------------------------------------------------------------------------------------------------------------------------------------------------------------------------------------------------------------------------------------------------------------------------------------------	--------------------------------------------------------------------------------------------------------------------------------------------------------------------------------------------------

Ticket/Invoice Information

Ticket for: ROBERT WILKIE
Date issued: 08/20/2020 Invoice nbr: 636827
Ticket Nbr: 0067613078190 Electronic Tkt: Yes Amount: (b)(4) USD
Form of Payment: VI*****00215

Ticket for: ROBERT WILKIE
Date issued: 08/20/2020 Invoice nbr: 636826
Ticket Nbr: 0017613078189 Electronic Tkt: Yes Amount: (b)(4) USD
Form of Payment: VI*****00215

Service Fee: ROBERT WILKIE
Date issued: 08/20/2020 Invoice Nbr: 636827
Document Nbr: 8900808124275 Amount: (b)(4) USD
Form of Payment: VI*****00215

Service Fee: ROBERT WILKIE
Date issued: 08/20/2020 Invoice Nbr: 636826
Document Nbr: 8900808124274 Amount: (b)(4) USD
Form of Payment: VI*****00215

Base Fare: (b)(4)
Tax: (b)(4)
Air Fare: (b)(4) (Vlxxxx00215)
Total Air Fare: (b)(4)
Service Fee: (b)(4) (Vlxxxx00215)
Total Invoiced: 1023.67

Click here 24 hours in advance to obtain boarding passes:

[American](#)
[DELTA](#)

Click here to review Baggage policies and guidelines:

[American](#)
[DELTA](#)

Check operating carrier website for any policies that may vary.

ZPIZAMERICAN AIR TICKET WAS CHARGED TO VI XXXXXXXXXXXXX0215
ZPIZAMERICAN AIR ELECTRONIC TICKET NUMBER IS 0017613078189
ZPIZINVOICE NUMBER IS 006368
ZPIZSERVICE FEE*****(b)(4)

ZPIZTICKETED FARE***** (b)(4) *****
ZPIZTOTAL CHARGE*****\$509.51
CB/CGEBILLING/ATRS/2020-08-20T14.59.00Z
ZPIZDELTA TICKET WAS CHARGED TO VI XXXXXXXXXXXXX0215
ZPIZDELTA ELECTRONIC TICKET NUMBER IS 0067613078190
ZPIZINVOICE NUMBER IS 006368
ZPIZSERVICE FEE***** (b)(4) *****
ZPIZTICKETED FARE***** (b)(4) *****
ZPIZTOTAL CHARGE*****\$514.16
CB/CGEBILLING/ATRS/2020-08-20T15.00.00Z

DUE TO RECENT CHANGES IN THE GOV CITY PAIR PROGRAM
YOUR AIR RESERVATIONS ARE SUBJECT TO CANCELLATION
BY THE AIRLINES IF NOT TICKETED AT LEAST 48 HOURS
PRIOR TO SCHEDULED DEPARTURE. PLEASE ENSURE ALL
NECESSARY APPROVALS ARE PROCESSED IN ACCORDANCE
WITH YOUR AGENCY'S BUSINESS RULE BUT NO LESS THAN 3
BUSINESS DAYS PRIOR TO DEPARTURE. THIS 48 HOUR
CANCELLATION RULE DOES NOT APPLY TO YOUR
INTERNATIONAL RESERVATIONS UNLESS YOUR TRIP HAS
DOMESTIC CONNECTIONS ON MORE THAN ONE AIRLINE OR
THESE RESERVATIONS WILL REQUIRE SEPARATE TICKETS.

101005341

**For travel agent assistance and emergencies, please call 1-877-813-5900.

Your TMC Code is "11T" Duluth Travel

New TSA guidelines

<https://www.tsa.gov/news/releases/2019/04/04/tsa-reminds-travelers-real-id-identification-requirements>



211 Mockingbird Lane • Johnson City, TN 37604
 Phone (423) 929-2000 • Fax (423) 929-1783
 Reservations
 www.doubletree.com

Name & Address

WILKIE, ROBERT

(b)(6)

UNITED STATES OF AMERICA

Room 533/NK1
 Arrival Date 9/2/2020 4:26:00 PM
 Departure Date 9/3/2020

Adult/Child 1/0
 Room Rate 96.00

Rate Plan: CVT
 HH # (b)(6)
 AL:
 Car:

Confirmation Number: 93569573

9/3/2020



DATE	REFERENCE	DESCRIPTION	AMOUNT
9/2/2020	1931439	GUEST ROOM	\$96.00
9/2/2020	1931439	ROOM SALES TAX	\$9.12
9/2/2020	1931439	CITY ROOM TAX	\$6.72
9/3/2020	1931503	VS (b)(6)	(\$111.84)
		BALANCE	\$0.00
EXPENSE REPORT SUMMARY			
		9/2/2020 STAY TOTAL	
ROOM AND TAX		\$111.84	\$111.84
DAILY TOTAL		\$111.84	\$111.84

Hilton Honors® stays are posted within 72 hours of checkout. To check your earnings or book your next stay at more than 5,700 hotels and resorts in 113 countries, please visit Honors.com



ACCOUNT NO
 VS (b)(6)

CARD MEMBER NAME
 WILKIE, ROBERT

ESTABLISHMENT NO & LOCATION ESTABLISHMENT ADDRESS TO TRANSMIT TO CARD HOLDER FOR PAYMENT

CARD MEMBER'S SIGNATURE
 X

DATE OF CHARGE FOLIO NO./CHECK NO.
 9/3/2020 508937 A

AUTHORIZATION INITIAL
 002960

PURCHASES & SERVICES

TAXES

TIPS & MISC

TOTAL AMOUNT -111.84

MERCHANDISE AND/OR SERVICES PURCHASED ON THIS CARD SHALL NOT BE RESOLD OR RETURNED FOR A CASH REFUND.

PAYMENT DUE UPON RECEIPT - 1.5% PER MONTH INTEREST CHARGE WILL BE APPLIED TO ALL PAST DUE INVOICES.





ATLANTA MARRIOTT MARQUIS

GUEST FOLIO

617	WILKIE/R	157.00	09/04/20	11:00	48032
ROOM	NAME	RATE	DEPART	TIME	ACCT#
GK			09/03/20	08:03	
TYPE			ARRIVE	TIME	
75					

ROOM	ADDRESS	PAYMENT	MBV#:	XXXXX (b)(6)
CLERK				

DATE	REFERENCES	CHARGES	CREDITS	BALANCES DUE
09/03	ROOM TR	617, 1	157.00	
09/03	STATE TX	617, 1	13.97	
09/03	CITY TAX	617, 1	12.56	
09/03	GA RMFEE	GA RMFEE	5.00	
09/04	VS CARD			\$188.53

TO BE SETTLED TO: VISA CURRENT BALANCE .00

THANK YOU FOR CHOOSING THE ATLANTA MARRIOTT MARQUIS!

See our "Privacy & Cookie Statement" on Marriott.com

Your Marriott Bonvoy points/miles earned on your eligible earnings will be credited to your account. Check your Marriott Bonvoy Account Statement for updated activity. See members.marriott.com for new Marriott Bonvoy benefits.



ATLANTA MARRIOTT MARQUIS
265 PEACHTREE CENTER
ATLANTA GA 30303

Treat yourself to the comfort of Marriott Hotels in your home. Visit ShopMarriott.com.

This statement is your only receipt. You have agreed to pay in cash or by approved personal check or to authorize us to charge your credit card for all amounts charged to you. The amounts shown in the credit column opposite any credit card entry in the reference column above will be charged to the credit card number set forth above. (The credit card company will bill in the usual manner.) If for any reason the credit card company does not make payment on this account, you will owe us such amount. If you are direct billed, in the event payment is not made within 25 days after check-out, you will owe us interest from the check-out date on any unpaid amount at the rate of 1.5% per month (ANNUAL RATE 18%), or the maximum allowed by law, plus the reasonable cost of collection, including attorney fees.

Signature X

Traveler

Passenger Name: WILKIE, ROBERT	e-Ticket Number: 0067613078190	Reservation Number: 25PALI	Issue Date: August 20, 2020
Invoice Number: 00636827	Total Charges to Date: USD 1023.67		

Agency Details

Agency Phone:
877-813-5900

Fare Information**Form Of Payment:**

VI XXXX XXXX XXXX 0215

Fare:	USD (b)(4)
Taxes and Carrier-imposed fees:	USD (b)(4)
	USD (b)(4)
Total Airfare:	USD (b)(4)
Service Fee: (MCO Number : 8900808124275)	USD (b)(4)
Total Invoice:	USD 514.16

Trip Information**Flight - American Airlines (AA) - 5163 - September 01, 2020**

Confirmation Number: EDYZNF	Status: Confirmed	
Depart: Ronald Reagan National Arpt (DCA) DC 6:00 PM	Arrive: Nashville (BNA) TN 6:51 PM	Class Of Service: Economy

Flight - American Airlines (AA) - 4499 - September 02, 2020

Confirmation Number:	Status:
-----------------------------	----------------

EDYZNF Confirmed

Depart:	Arrive:	Class Of Service:
Nashville (BNA)	Charlotte (CLT)	Economy
TN	NC	
2:26 PM	5:00 PM	

Flight - American Airlines (AA) - 4814 - September 02, 2020

Status:
Confirmed

Depart:	Arrive:	Class Of Service:
Charlotte (CLT)	Tri City Regional Arpt (TRI)	Economy
NC	TN	
6:10 PM	7:12 PM	

Flight - Delta Air Lines (DL) - 4839 - September 03, 2020

Confirmation Number: HTK2HZ
Status: Confirmed

Depart:	Arrive:	Class Of Service:
Tri City Regional Arpt (TRI)	Hartsfield Jackson Intl Arpt	Economy
TN	(ATL)	
3:49 PM	GA	
	5:00 PM	

Flight - Delta Air Lines (DL) - 1749 - September 04, 2020

Confirmation Number: HTK2HZ
Status: Confirmed

Depart:	Arrive:	Class Of Service:
Hartsfield Jackson Intl Arpt	Ronald Reagan National Arpt	Economy
(ATL)	(DCA)	
GA	DC	
4:27 PM	6:15 PM	

Misc - June 16, 2021

Location Info: Phone:
Other Info: Number of Persons: 1

Remark: THIS DATE FOR
ACCOUNTING PURPOSES ONLY

Agent Comments

DUE TO RECENT CHANGES IN THE GOV CITY PAIR PROGRAM
YOUR AIR RESERVATIONS ARE SUBJECT TO CANCELLATION
BY THE AIRLINES IF NOT TICKETED AT LEAST 48 HOURS
PRIOR TO SCHEDULED DEPARTURE. PLEASE ENSURE ALL
NECESSARY APPROVALS ARE PROCESSED IN ACCORDANCE
WITH YOUR AGENCYS BUSINESS RULE BUT NO LESS THAN 3
BUSINESS DAYS PRIOR TO DEPARTURE. THIS 48 HOUR
CANCELLATION RULE DOES NOT APPLY TO YOUR
INTERNATIONAL RESERVATIONS UNLESS YOUR TRIP HAS
DOMESTIC CONNECTIONS ON MORE THAN ONE AIRLINE OR
THESE RESERVATIONS WILL REQUIRE SEPARATE TICKETS.

101005341

ZPIZAMERICAN AIR TICKET WAS CHARGED TO VI XXXXXXXXXXXX0215

ZPIZAMERICAN AIR ELECTRONIC TICKET NUMBER IS 0017613078189

ZPIZINVOICE NUMBER IS 006368

ZPIZSERVICE FEE***** (b)(4)

ZPIZTICKETED FARE***** (b)(4)

ZPIZTOTAL CHARGE*****\$509.51

CB/CGEBILLING/ATRS/2020-08-20T14.59.00Z

ZPIZDELTA TICKET WAS CHARGED TO VI XXXXXXXXXXXX0215

ZPIZDELTA ELECTRONIC TICKET NUMBER IS 0067613078190

ZPIZINVOICE NUMBER IS 006368

ZPIZSERVICE FEE***** (b)(4)

ZPIZTICKETED FARE***** (b)(4)

ZPIZTOTAL CHARGE*****\$514.16

CB/CGEBILLING/ATRS/2020-08-20T15.00.00Z

Traveler

Passenger Name: WILKIE, ROBERT@	e-Ticket Number: 0017613078189	Reservation Number: 25PALI	Issue Date: August 20, 2020
Invoice Number: 00636826	Total Charges to Date: USD 1023.67		

Agency Details

Agency Phone:
877-813-5900

Fare Information**Form Of Payment:**

VI XXXX XXXX XXXX 0215

Fare:	USD (b)(4)
Taxes and Carrier-imposed fees:	USD
	USD
Total Airfare:	USD
Service Fee: (MCO Number : 8900808124274)	USD
Total Invoice:	USD 509.51

Trip Information**Flight - American Airlines (AA) - 5163 - September 01, 2020**

Confirmation Number: EDYZNF	Status: Confirmed
---------------------------------------	-----------------------------

Depart: Ronald Reagan National Arpt (DCA) DC 6:00 PM	Arrive: Nashville (BNA) TN 6:51 PM	Class Of Service: Economy
-------------------------------------------------------------------------	----------------------------------------------------	-------------------------------------

Flight - American Airlines (AA) - 4499 - September 02, 2020

Confirmation Number:	Status:
-----------------------------	----------------

EDYZNF Confirmed

Depart:	Arrive:	Class Of Service:
Nashville (BNA)	Charlotte (CLT)	Economy
TN	NC	
2:26 PM	5:00 PM	

Flight - American Airlines (AA) - 4814 - September 02, 2020

Status:
Confirmed

Depart:	Arrive:	Class Of Service:
Charlotte (CLT)	Tri City Regional Arpt (TRI)	Economy
NC	TN	
6:10 PM	7:12 PM	

Flight - Delta Air Lines (DL) - 4839 - September 03, 2020

Confirmation Number: HTK2HZ
Status: Confirmed

Depart:	Arrive:	Class Of Service:
Tri City Regional Arpt (TRI)	Hartsfield Jackson Intl Arpt	Economy
TN	(ATL)	
3:49 PM	GA	
	5:00 PM	

Flight - Delta Air Lines (DL) - 1749 - September 04, 2020

Confirmation Number: HTK2HZ
Status: Confirmed

Depart:	Arrive:	Class Of Service:
Hartsfield Jackson Intl Arpt	Ronald Reagan National Arpt	Economy
(ATL)	(DCA)	
GA	DC	
4:27 PM	6:15 PM	

Misc - June 16, 2021

Location Info: Phone:
Other Info: Number of Persons: 1

Remark: THIS DATE FOR
ACCOUNTING PURPOSES ONLY

Agent Comments

DUE TO RECENT CHANGES IN THE GOV CITY PAIR PROGRAM
YOUR AIR RESERVATIONS ARE SUBJECT TO CANCELLATION
BY THE AIRLINES IF NOT TICKETED AT LEAST 48 HOURS
PRIOR TO SCHEDULED DEPARTURE. PLEASE ENSURE ALL
NECESSARY APPROVALS ARE PROCESSED IN ACCORDANCE
WITH YOUR AGENCYS BUSINESS RULE BUT NO LESS THAN 3
BUSINESS DAYS PRIOR TO DEPARTURE. THIS 48 HOUR
CANCELLATION RULE DOES NOT APPLY TO YOUR
INTERNATIONAL RESERVATIONS UNLESS YOUR TRIP HAS
DOMESTIC CONNECTIONS ON MORE THAN ONE AIRLINE OR
THESE RESERVATIONS WILL REQUIRE SEPARATE TICKETS.

101005341

ZPIZAMERICAN AIR TICKET WAS CHARGED TO VI XXXXXXXXXXXX0215

ZPIZAMERICAN AIR ELECTRONIC TICKET NUMBER IS 0017613078189

ZPIZINVOICE NUMBER IS 006368

ZPIZSERVICE FEE***** (b)(4)

ZPIZTICKETED FARE***** (b)(4)

ZPIZTOTAL CHARGE*****\$509.51

CB/CGEBILLING/ATRS/2020-08-20T14.59.00Z

ZPIZDELTA TICKET WAS CHARGED TO VI XXXXXXXXXXXX0215

ZPIZDELTA ELECTRONIC TICKET NUMBER IS 0067613078190

ZPIZINVOICE NUMBER IS 006368

ZPIZSERVICE FEE***** (b)(4)

ZPIZTICKETED FARE***** (b)(4)

ZPIZTOTAL CHARGE*****\$514.16

CB/CGEBILLING/ATRS/2020-08-20T15.00.00Z

Document Header Information

Document Type:	Voucher	Document Name:	VCH21000345
Travel Authorization Number:	101005899	Trip Name:	West Haven, CT and Providence, RI - Site visits
TA Date:	09/23/20	Currency:	USD
Organization:	VAVACO 101 OFFICE OF THE SECRETARY	Current Status:	CREATED
Purpose:	SITE VISIT	Document Detail:	West Haven, CT and Providence, RI - Site visits
Type Code:	REGULAR TDY		

Traveler Profile

Name:	WILKIE, ROBERT L	ID:	(b)(6)
TID:	(b)(6)	Organization:	VAVACO 101 OFFICE OF THE SECRETARY
Title:	SECRETARY OF VETERANS AFFAIRS	Duty Station:	Washington, DC
Security Cl:		Card:	IBA HLDR NON-EXEMPT
Office Address:	810 Vermont Ave NW Washington, DC 20420	EMAIL:	(b)(6)@va.gov
Office Phone:	(b)(6)	Cell Phone:	
Home Address:		Home Phone:	(b)(6)
Alternate Address:		Alternate Phone:	

Document Information

Trip Number: 1
Purpose: West Haven, CT and Providence, RI - Site visits

Itinerary Locations

From	To	Itinerary Location	Purpose	Per Diem Rates
09/16/20	09/17/20	ORANGE, CT	SITE VISIT	114.00 / 61.00

Document Totals

Total Expenses:	568.80
Reimbursable Expenses:	222.60
Non-Reimbursable Expenses:	346.20
Advance Applied:	.00
Net to Traveler:	23.77
Net to Government:	346.20
Pay to Charge Card:	198.83

Document Totals by Expense Category

Expense Category	Cost	Advance Amount
Com. Carrier	331.70	.00
Lodging-Per Diem	131.10	.00
M&IE-Per Diem	91.50	.00
Transxn Fees	14.50	.00
Total Expenses:	568.80	.00

Trip 1 Details**Expenses**

Trip#: 1	Total Non-Per Diem Expenses:	363.30	Total Per Diem Expenses:	205.50	
Date	Description	Category	Cost	Pay Method	Per Diem
09/16/2020	Airline Flight	Com. Carrier	331.70	CBA	
09/16/2020	Lodging	Lodging-Per Diem	114.00	IBA	*
09/16/2020	Hotel Taxes	Lodging-Per Diem	17.10	IBA	
09/16/2020	M&IE	M&IE-Per Diem	45.75	OTHER	*
09/16/2020	Government Vehicle	Transportation	.00	OTHER	
09/17/2020	M&IE	M&IE-Per Diem	45.75	OTHER	*
09/17/2020	Government Vehicle	Transportation	.00	OTHER	
09/23/2020	TDY Voucher Fee	Transxn Fees	14.50	CBA	

Per Diem Allowances

Trip#: 1		Total Per Diem Allowances:				205.50
Date	Rate	Ldg Cost	Ldg Allowed	M&IE Cost	M&IE Allowed	B L D Cont%
09/16/2020	114.00/ 61.00	114.00	114.00	45.75	45.75	
09/17/2020	114.00/ 61.00	0.00	0.00	45.75	45.75	

Advance of Funds

Account Summary for the Selected Trip

Org: VAVACO 101 OFFICE OF THE SECRETARY	Label: VA VACO 101 OSVA	Acct Code: 000000A0011010004 0142A1101 20/2172	568.80
Expense Category: Com. Carrier	Fiscal Year: 2020	Amount: 331.70	
Expense Category: Lodging-Per Diem	Fiscal Year: 2020	Amount: 131.10	
Expense Category: M&IE-Per Diem	Fiscal Year: 2020	Amount: 91.50	
Expense Category: Transxn Fees	Fiscal Year: 2020	Amount: 14.50	
Total:			568.80

Payment Detail Information

Organization	Label	Accounting String	Payment Method	Amount
VAVACO 101 OFFICE OF THE SECRETARY	VA VACO 101 OSVA	000000A0011010004 0142A1101 20/2172	CBA	346.20
VAVACO 101 OFFICE OF THE SECRETARY	VA VACO 101 OSVA	000000A0011010004 0142A1101 20/2172	IBA	131.10
VAVACO 101 OFFICE OF THE SECRETARY	VA VACO 101 OSVA	000000A0011010004 0142A1101 20/2172	OTHER	91.50

Totals by Label

VAVACO 101 OFFICE OF THE SECRETARY	VA VACO 101 OSVA Total	000000A0011010004 0142A1101 20/2172	568.80
------------------------------------	------------------------	-------------------------------------	--------

Totals by Payment Method

CBA Total	346.20
IBA Total	131.10
OTHER Total	91.50

Attachments

Attachments Exist

Receipt Checklist

Date	Description	Cost
09/16/20	AIR Airline Flight	\$331.70
09/16/20	Lodging	\$114.00
09/16/20	Hotel Taxes	\$17.10

Audits

Audit Name	Result	Reason
------------	--------	--------

Document History 09/30/2020 Voucher: VCH21000345

Copyright 1989-2009 Concur Government Edition: Concur Inc. WILKIE, ROBERT L. (b)(6)

STATUS	DATE	TIME	SIGNATURE NAME	REASON
CREATED	09/23/2020	11:01AM EST	(b)(6)	

I certify that the electronic signatures listed above are valid and on file

(b)(6) _____ 30 Sep 2020
SIGN DATE

I certify this claim is true and correct to the best of my knowledge and belief, and that payment or credit has not been received by me or the traveler (if signed by alternate representative). I understand there are severe criminal and civil penalties for knowingly submitting a false, fictitious or fraudulent claim (18 U.S.C. Sections 287 and 1001, and 31 U.S.C. Section 3729).

Document Signatures

Traveler Name: Robert L. Wilkie

Traveler Signature: *Robert L. Wilkie*

Date: 5 OCT 20

Approver Name: _____

Approver Signature: _____

Date: _____

Note

\$23.77 net to SECVA

\$198.83 pay to government charge card (IBA)

FOR OFFICIAL USE ONLY – DO NOT DISTRIBUTE
FINAL 1
THE HONORABLE ROBERT WILKIE
SECRETARY OF VETERANS AFFAIRS
TRAVEL ITINERARY
WEST HAVEN / NEWINGTON, CT
SEPTEMBER 16-17, 2020

TRAVELING PARTY:

The Honorable Robert Wilkie
 Michael Meador, Special Assistant to the Secretary
 Traci Scott, Senior Advisor for Strategic Communications

(b)(6)

EXECUTIVE PROTECTION:

(b)(6); (b)(7)(C) Special Agent (DL)
 Special Agent, (Adv)

(b)(6); (b)(7)(C) c
 c

EVENT / SITE POCs:

(b)(6), Executive Assistant to the Director, VA Connecticut Healthcare System

(b)(6)

SCHEDULING POCs:

Edward “Ted” Diaz, Staff Assistant, OSVA (Adv)
 (b)(6) Travel Coordinator, OSVA
 (b)(6) - Travel Coordinator, OSVA

(b)(6)

Wednesday, September 16, 2020

Attire: Business

Weather: Washington, DC H-76°; L-62° - Partly Cloudy
 West Haven, CT H-74°; L-61° - Mostly Cloudy

1530-1545 ERT / ARRIVE WASHINGTON REAGAN NATIONAL AIRPORT (15 min)
 1 Aviation Circle, Arlington, VA
 Drive time: 15 min / 3.6 miles

1643 WHEELS UP TO HARTFORD BRADLEY INTERNATIONAL AIRPORT (BDL)
 American Airlines 4584, DCA-PHL, 1643-1748, 1 hr 5 min
 Layover Philadelphia, PA 53 min
 American Airlines 5069, PHL-BDL, 1841-1953, 1 hr 12 min
 Total Travel Time: 3 hr 10 min

1953 WHEELS DOWN HARTFORD BRADLEY INTERNATIONAL AIRPORT (BDL)
 Schoephoester Rd, Windsor Locks, CT 06096

2010-2115 ERT / ARRIVE COURTYARD NEW HAVEN ORANGE/MILFORD (1 hr)
 136 Marsh Hill Rd., Orange, CT 06477
 Drive Time: 1 h / 58.8 miles

RON

**FOR OFFICIAL USE ONLY – DO NOT DISTRIBUTE
FINAL 1**

Thursday, September 17, 2020

Attire: Business

Weather:	West Haven, CT	H-79°; L-58° - Mostly Cloudy
	Newington, CT	H-74°; L-58° - Sunny
	Washington, DC	H-78°; L-60° - Cloudy

0725-0745 ERT / ARRIVE VA CONNECTICUT HEALTHCARE SYSTEM, WEST HAVEN CAMPUS (20 min)

950 Campbell Ave. West Haven, CT 06516

Drive Time: 10 min / 3.8 miles

Greeted By:

- Mr. Barrett Franklin, VISN 1 Deputy Network Director
- Alfred Montoya, Director, VA Connecticut Healthcare System, West Haven Campus
- John Callahan, Deputy Director
- Dr. Michael Kozal, Chief of Staff
- Dr. Bernadette Jao, Associate Director for Patient Care & Nursing Services
- Ross Hildonen, Assistant Director
- (b)(6) HSS/EA to the Director
- (b)(6); (b)(7)(C) Chief, Police Service

0745-0755 INTRODUCTION TO COVID-19 ENTRANCE SCREENING AREA (10 min)

0800-0845 LEADERSHIP BRIEFING (45 min)

Location: Building 2, Donaldson Center

Topics:

- COVID-19 Snapshot
- Research
- Clinical and Educational Missions
- Construction Projects

Attendees:

- Mr. Barrett Franklin, VISN 1 Deputy Network Director
- Alfred Montoya, Director
- John Callahan, Deputy Director
- Dr. Michael Kozal, Chief of Staff
- Dr. (b)(6) Deputy Chief of Staff
- Dr. Bernadette Jao, Associate Director for Patient Care & Nursing Services (ADPCNS)
- Susan Trimboli, Deputy Associate Director for Patient Services
- Ross Hildonen, Assistant Director
- (b)(6) Strategic Business Partner
- Dr. (b)(6) Medical Director of HPACT (Homeless Patient Care Aligned Team)
- Dr. (b)(6), Director, Hospital Epidemiology and Infection Prevention
- (b)(6), HSS/EA to the Director
- (b)(6); (b)(7)(C), Chief, Police Service
- (b)(6), Chief, Quality Management

**FOR OFFICIAL USE ONLY – DO NOT DISTRIBUTE
FINAL 1**

- Dr. (b)(6), Chief, Occupational Health Services
- Mr. (b)(6), HSS to the ADPCNS

0845-0855 COIN RECOGNITION (10 min)

Location: Building 2, 3rd Floor, Community Living Center/Chapel

Recipients:

- (b)(6) CLC Long Term Resident; Vietnam Veteran (USMC) *Due to COVID precautions, Mr. (b)(6) will be coined separately in the CLC Chapel.
- Dr. (b)(6) Primary Care Team, Infectious Disease Specialty
- (b)(6) Telehealth Clinic Technician
- (b)(6) Emergency Manager
- (b)(6) Supervisor, Virology Laboratory
- (b)(6) Voluntary Services

0855-0940 FACILITY TOUR (45 min)

Tour Led By: Alfred Montoya, Director

Highlighted Areas:

- Community Living Center / Chapel
- Laboratory, Building 1
- 6 East (COVID-19 Ward)

0945-0950 EXECUTIVE TIME

0950-0955 MEDIA PREP (5 min)

Location: Building 2, 5th Floor, Executive Suite

0955-1000 TRANSITION TO MEDIA AVAILABILITY

1000-1025 MEDIA AVAILABILITY (25 min)

Location: Across from the main entrance to the VAMC

- Local NBC Affiliate

1030-1115 ERT / ARRIVE NEWINGTON VA CLINIC (45 min)

555 Willard Ave. Newington, CT 06111

Urgent Care Entrance

Drive Time: 45 min / 40 mile

Greeted By:

- Mr. Barrett Franklin, VISN 1 Deputy Network Director
- Alfred Montoya, Director, VA Connecticut Healthcare System, West Haven Campus

1115-1125 INTRODUCTION TO COVID-19 ENTRANCE SCREENING AREA (10 min)

1125-1210 FACILITY TOUR / LEADERSHIP BRIEFING (45 min)

Led By: Alfred Montoya, Director

**FOR OFFICIAL USE ONLY – DO NOT DISTRIBUTE
FINAL 1**

Highlighted Areas:

- Urgent Care
- Primary Care
- COVID Screening Area

Attendees:

- Mr. Barrett Franklin, VISN 1 Deputy Network Director
- Alfred Montoya, Director
- Dr. Bernadette Jao, ADPCNS
- Dr. Michael Kozal, Chief of Staff
- Dr. (b)(6) Director of Primary Care
- Ross Hildonen, Assistant Director

- 1210-1220 COIN RECOGNITION (10 min)**
Location: 1st Floor Primary Care Waiting Area
Recipient: Dr. (b)(6) Primary Care Team, Telemedicine
- 1220-1225 EXECUTIVE TIME (5 min)**
- 1225-1230 MEDIA PREP (5 min)**
Location: Director's Suite
- 1230-1300 MEDIA HOLD (30 min)**
Location: Director's Suite
- 1310-1345 ERT / ARRIVE HARTFORD BRADLEY INTERNATIONAL AIRPORT (BDL)**
Schoephoester Rd, Windsor Locks, CT 06096
Drive Time: 35 min / 29 mile
- 1350-1435 LUNCH (45 min)**
- 1435-1449 EXECUTIVE TIME (14 min)**
- 1449-1529 GATE TRANSITION / AIRCRAFT BOARDING (45 min)**
- 1529 WHEELS UP WASHINGTON REAGAN NATIONAL AIRPORT**
American Airlines 4364, BDL-PHL, 1529-1649, 1 hr 20 min
Layover Philadelphia, PA, 1 hr 52 min
American Airlines 2392, PHL-DCA, 1841-1945, 1 hr 4 min
Total Travel Time: 4 hr 16 min
- 1945 WHEELS DOWN WASHINGTON REAGAN NATIONAL AIRPORT (DCA)**
1 Aviation Circle, Arlington, VA
- 2000-2015 ERT / ARRIVE RESIDENCE (15 min)**
Drive Time: 15 min / ## miles

Courtyard by Marriott® New Haven Orange
136 Marsh Hill Rd, Orange, Ct 06477 P 203.799.2200
Marriott.com/HVNCO

Robert Wilkie

(b)(6)

Room: 302
Room Type: GENR
Number of Guests: 1
Rate: \$114.00

Clerk: (b)(6)

Arrive: 16Sep20 Time: 02:06PM Depart: 17Sep20 Time: 06:57AM Folio Number: 99906

DATE	DESCRIPTION	CHARGES	CREDITS
16Sep20	Market Beverage	6.00	
16Sep20	Sales Tax	0.44	
16Sep20	Market Packaged Food	6.00	
16Sep20	Sales Tax	0.44	
16Sep20	Market Packaged Food	7.00	
16Sep20	Sales Tax	0.51	
16Sep20	Room Charge	114.00	
16Sep20	Room Tax	17.10	
17Sep20	Visa		151.49
Card #: VIXXXXXXXXXXX (b)(6) XXXX			
Amount: 151.49 Auth: 010924			

BALANCE: 0.00

Marriott Bonvoy Account # XXXX (b)(6) Your Marriott Bonvoy points/miles earned on your eligible earnings will be credited to your account. Check your Marriott Bonvoy account statement or your online statement for updated activity.

See our "Privacy & Cookie Statement" on Marriott.com.

Traveler

Passenger Name: WILKIE, ROBERT@	e-Ticket Number: 0017613729825	Reservation Number: NY3PSX	Issue Date: September 15, 2020
Invoice Number: 00637320	Total Charges to Date: USD 618.72		

Agency Details**Agency Phone:**

877-813-5900

Fare Information**Form Of Payment:**

VI XXXX XXXX XXXX 0215

Fare:	USD (b)(4)
Taxes and Carrier-imposed fees:	USD
	USD
Total Airfare:	USD
Service Fee: (MCO Number : 8900808209618)	USD
Total Invoice:	USD 276.81

Trip Information**Flight - American Airlines (AA) - 4584 - September 16, 2020****Status:**

Cancelled

Depart: Washington-National (DCA) DC 4:43 PM	Arrive: Philadelphia (PHL) PA 5:48 PM	Class Of Service: Economy
--------------------------------------------------------------	-------------------------------------------------------	-------------------------------------

Flight - American Airlines (AA) - 4584 - September 16, 2020**Status:**

Confirmed

Depart:	Arrive:	Class Of Service:
Washington-National (DCA)	Philadelphia (PHL)	First Class
DC	PA	
4:43 PM	5:48 PM	

Flight - American Airlines (AA) - 5069 - September 16, 2020

Status:
Confirmed

Depart:	Arrive:	Class Of Service:
Philadelphia (PHL)	Hartford (BDL)	Economy
PA	CT	
6:41 PM	7:53 PM	

Flight - American Airlines (AA) - 4364 - September 17, 2020

Confirmation Number:	Status:
BXLISN	Confirmed

Depart:	Arrive:	Class Of Service:
Hartford (BDL)	Philadelphia (PHL)	First Class
CT	PA	
3:29 PM	4:49 PM	

Flight - American Airlines (AA) - 2392 - September 17, 2020

Status:
Confirmed

Depart:	Arrive:	Class Of Service:
Philadelphia (PHL)	Washington-National (DCA)	Economy
PA	DC	
6:41 PM	7:45 PM	

Misc - July 08, 2021

Location Info:	Other Info:
Phone:	Number of Persons: 1
	Remark: THIS DATE FOR
	ACCOUNTING PURPOSES ONLY

Agent Comments

DUE TO RECENT CHANGES IN THE GOV CITY PAIR PROGRAM
YOUR AIR RESERVATIONS ARE SUBJECT TO CANCELLATION
BY THE AIRLINES IF NOT TICKETED AT LEAST 48 HOURS
PRIOR TO SCHEDULED DEPARTURE. PLEASE ENSURE ALL
NECESSARY APPROVALS ARE PROCESSED IN ACCORDANCE
WITH YOUR AGENCYS BUSINESS RULE BUT NO LESS THAN 3
BUSINESS DAYS PRIOR TO DEPARTURE. THIS 48 HOUR
CANCELLATION RULE DOES NOT APPLY TO YOUR
INTERNATIONAL RESERVATIONS UNLESS YOUR TRIP HAS
DOMESTIC CONNECTIONS ON MORE THAN ONE AIRLINE OR
THESE RESERVATIONS WILL REQUIRE SEPARATE TICKETS.

101005899
ZPIZAMERICAN AIR TICKET WAS CHARGED TO VI XXXXXXXXXXXX0215
ZPIZAMERICAN AIR ELECTRONIC TICKET NUMBER IS 0017613251330
ZPIZINVOICE NUMBER IS 006372
ZPIZSERVICE FEE***** (b)(4)
ZPIZTICKETED FARE***** (b)(4)
ZPIZTOTAL CHARGE*****\$341.91
CB/CGEBILLING/ATRS/2020-09-11T16.09.00Z

101005899
ZPIZAMERICAN AIR TICKET WAS CHARGED TO VI XXXXXXXXXXXX0215
ZPIZAMERICAN AIR ELECTRONIC TICKET NUMBER IS 0017613251330
ZPIZINVOICE NUMBER IS 006372
ZPIZSERVICE FEE***** (b)(4)
ZPIZTICKETED FARE***** (b)(4)
ZPIZTOTAL CHARGE*****\$341.91
CB/CGEBILLING/ATRS/2020-09-15T13.25.00Z

ZPIZAMERICAN AIR TICKET WAS CHARGED TO VI XXXXXXXXXXXX0215
ZPIZAMERICAN AIR ELECTRONIC TICKET NUMBER IS 0017613729825
ZPIZINVOICE NUMBER IS 006373
ZPIZSERVICE FEE***** (b)(4)
ZPIZTICKETED FARE***** (b)(4)
ZPIZTOTAL CHARGE*****\$276.81
CB/CGEBILLING/ATRS/2020-09-15T13.34.00Z

Traveler**Passenger Name:**

WILKIE, ROBERT@

e-Ticket Number:

0017613251330

Reservation Number:

NY3PSX

Issue Date:

September 11, 2020

Invoice Number:

00637240

Total Charges to Date:

USD 618.72

Agency Details**Agency Phone:**

877-813-5900

Fare Information**Form Of Payment:**

VI XXXX XXXX XXXX 0215

Fare:

USD (b)(4)

Taxes and Carrier-imposed fees:

USD

USD

Total Airfare:

USD

Service Fee: (MCO Number : 8900808193788)

USD

Total Invoice:

USD 341.91

Trip Information**Flight - American Airlines (AA) - 4584 - September 16, 2020****Status:**

Cancelled

Depart:

Washington-National (DCA)

DC

4:43 PM

Arrive:

Philadelphia (PHL)

PA

5:48 PM

Class Of Service:

Economy

Flight - American Airlines (AA) - 4584 - September 16, 2020**Status:**

Confirmed

Depart:	Arrive:	Class Of Service:
Washington-National (DCA)	Philadelphia (PHL)	First Class
DC	PA	
4:43 PM	5:48 PM	

Flight - American Airlines (AA) - 5069 - September 16, 2020

Status:
Confirmed

Depart:	Arrive:	Class Of Service:
Philadelphia (PHL)	Hartford (BDL)	Economy
PA	CT	
6:41 PM	7:53 PM	

Flight - American Airlines (AA) - 4364 - September 17, 2020

Confirmation Number:	Status:
BXLISN	Confirmed

Depart:	Arrive:	Class Of Service:
Hartford (BDL)	Philadelphia (PHL)	First Class
CT	PA	
3:29 PM	4:49 PM	

Flight - American Airlines (AA) - 2392 - September 17, 2020

Status:
Confirmed

Depart:	Arrive:	Class Of Service:
Philadelphia (PHL)	Washington-National (DCA)	Economy
PA	DC	
6:41 PM	7:45 PM	

Misc - July 08, 2021

Location Info:	Other Info:
Phone:	Number of Persons: 1
	Remark: THIS DATE FOR
	ACCOUNTING PURPOSES ONLY

Agent Comments

DUE TO RECENT CHANGES IN THE GOV CITY PAIR PROGRAM
YOUR AIR RESERVATIONS ARE SUBJECT TO CANCELLATION
BY THE AIRLINES IF NOT TICKETED AT LEAST 48 HOURS
PRIOR TO SCHEDULED DEPARTURE. PLEASE ENSURE ALL
NECESSARY APPROVALS ARE PROCESSED IN ACCORDANCE
WITH YOUR AGENCYS BUSINESS RULE BUT NO LESS THAN 3
BUSINESS DAYS PRIOR TO DEPARTURE. THIS 48 HOUR
CANCELLATION RULE DOES NOT APPLY TO YOUR
INTERNATIONAL RESERVATIONS UNLESS YOUR TRIP HAS
DOMESTIC CONNECTIONS ON MORE THAN ONE AIRLINE OR
THESE RESERVATIONS WILL REQUIRE SEPARATE TICKETS.

101005899
ZPIZAMERICAN AIR TICKET WAS CHARGED TO VI XXXXXXXXXXXX0215
ZPIZAMERICAN AIR ELECTRONIC TICKET NUMBER IS 0017613251330
ZPIZINVOICE NUMBER IS 006372

ZPIZSERVICE FEE***** (b)(4)

ZPIZTICKETED FARE***** (b)(4)

ZPIZTOTAL CHARGE*****\$341.91

CB/CGEBILLING/ATRS/2020-09-11T16.09.00Z

101005899
ZPIZAMERICAN AIR TICKET WAS CHARGED TO VI XXXXXXXXXXXX0215
ZPIZAMERICAN AIR ELECTRONIC TICKET NUMBER IS 0017613251330
ZPIZINVOICE NUMBER IS 006372

ZPIZSERVICE FEE***** (b)(4)

ZPIZTICKETED FARE***** (b)(4)

ZPIZTOTAL CHARGE*****\$341.91

CB/CGEBILLING/ATRS/2020-09-15T13.25.00Z

ZPIZAMERICAN AIR TICKET WAS CHARGED TO VI XXXXXXXXXXXX0215
ZPIZAMERICAN AIR ELECTRONIC TICKET NUMBER IS 0017613729825
ZPIZINVOICE NUMBER IS 006373

ZPIZSERVICE FEE***** (b)(4)

ZPIZTICKETED FARE***** (b)(4)

ZPIZTOTAL CHARGE*****\$276.81

CB/CGEBILLING/ATRS/2020-09-15T13.34.00Z



Duluth Government
 2860 Peachtree Ind. Blvd., Suite 1000
 Duluth, GA 30097
 Phone: (877) 813-5900

Tuesday, 15SEP 2020 8:39 AM EDT

Passengers: ROBERT WILKIE (101005899/ 101005899)

Agency Reference Number: NY3PSX

Click here to view your current itinerary or ETicket receipt on-line: viewtrip.travelport.com

Do you have your REAL ID to travel? Click HERE for more information.

Enjoy parking discounts from Duluth Travel Inc HERE

AIR	Wednesday, 16SEP 2020		
American Airlines			
OPERATED BY REPUBLIC AIRWAYS AS AMERICAN EAGLE		Flight Number: 4584	Class: G- Coach/Economy
From: Washington Reagan Natl DC, USA		Depart: 4:43 PM	
To: Philadelphia PA, USA		Arrive: 5:48 PM	
Stops: Nonstop		Duration: 1 hour(s) 5 minute(s)	
Seats: 13C		Status: CONFIRMED	Miles: 127 / 203 KM
Equipment: EMBRAER EMB 175			
DEPARTS DCA TERMINAL C			
Frequent Flyer Number: (b)(6)			
Fare Basis: GCADCA			
American Airlines Confirmation number is BXLISN			

AIR	Wednesday, 16SEP 2020		
American Airlines			
OPERATED BY PSA AIRLINES AS AMERICAN EAGLE		Flight Number: 5069	Class: G- Coach/Economy
From: Philadelphia PA, USA		Depart: 6:41 PM	
To: Bradley Intl/Hartford CT, USA		Arrive: 7:53 PM	
Stops: Nonstop		Duration: 1 hour(s) 12 minute(s)	
Seats: 12C		Status: CONFIRMED	Miles: 195 / 312 KM
Equipment: CRJ-700 Canadair Regional Jet			
DEPARTS PHL TERMINAL F			
Frequent Flyer Number: (b)(6)			
SEATS NOT AVAILBLE. AIRPORT CHECK-IN			
Fare Basis: GCADCA			
American Airlines Confirmation number is BXLISN			

HOTEL	Wednesday, 16SEP 2020		
<u>Courtyard Orange Marriott (COURTYARD BY MARRIOTT)</u>			
136 Marsh Hill RD Orange CT 06477			
Number of Rooms: 1		Confirmation Number: 75096092	

Phone: 1 203 799-2200

Fax: 1 203 799-2626

Rate: USD 114.00

Room GUARANTEED TO VISA

Check Out: Thursday, 17SEP 2020

Reserved For: WILKIE ROBERT

Room Type: GOVA00

Guaranteed to: VI*****

Hotel cancellation policy: CANCEL PERMITTED UP TO 01 DAYS BEFORE ARRIVAL. 131.10 CANCEL FEE PER ROOM.

AIR	Thursday, 17SEP 2020	
American Airlines		
OPERATED BY REPUBLIC AIRWAYS AS AMERICAN EAGLE		
Flight Number: 4364	Class: G- Coach/Economy	
From: Bradley Intl/Hartford CT, USA	Depart: 3:29 PM	
To: Philadelphia PA, USA	Arrive: 4:49 PM	
Stops: Nonstop	Duration: 1 hour(s) 20 minute(s)	
Seats: 20D	Status: CONFIRMED	Miles: 195 / 312 KM
Equipment: EMBRAER EMB 175		
Frequent Flyer Number: <input type="text" value="(b)(6)"/>		
Fare Basis: GCADCA		
American Airlines Confirmation number is BXLISN		

AIR	Thursday, 17SEP 2020	
American Airlines		
Flight Number: 2392		
Class: G- Coach/Economy		
From: Philadelphia PA, USA		
To: Washington Reagan Natl DC, USA		
Depart: 6:41 PM		
Arrive: 7:45 PM		
Stops: Nonstop		
Duration: 1 hour(s) 4 minute(s)		
Seats: 22D		
Status: CONFIRMED		
Miles: 127 / 203 KM		
Equipment: Airbus Jet		
ARRIVES DCA TERMINAL C		
Frequent Flyer Number: <input type="text" value="(b)(6)"/>		
Fare Basis: GCADCA		
American Airlines Confirmation number is BXLISN		

Ticket/Invoice Information

Ticket for: ROBERT WILKIE
Date issued: 09/15/2020 Invoice nbr: 637320
Ticket Nbr: 0017613729825 Electronic Tkt: Yes Amount: USD
Form of Payment: VI*****00215

Service Fee: ROBERT WILKIE
Date issued: 09/15/2020 Invoice Nbr: 637320
Document Nbr: 8900808209618 Amount: USD
Form of Payment: VI*****00215

Base Fare:
Tax:
Air Fare: (Ixxxx00215)
Total Air Fare:
Service Fee: (Ixxxx00215)
Total Invoiced: 276.81

Click here 24 hours in advance to obtain boarding passes:

[American](#)

Click here to review Baggage policies and guidelines:

[American](#)

Check operating carrier website for any policies that may vary.

ZPIZAMERICAN AIR TICKET WAS CHARGED TO VI XXXXXXXXXXXXX0215
ZPIZAMERICAN AIR ELECTRONIC TICKET NUMBER IS 0017613251330
ZPIZINVOICE NUMBER IS 006372
ZPIZSERVICE FEE***** (b)(4) *****
ZPIZTICKETED FARE***** (b)(4) *****
ZPIZTOTAL CHARGE*****\$341.91
CB/CGEBILLING/ATRS/2020-09-11T16.09.00Z

ZPIZAMERICAN AIR TICKET WAS CHARGED TO VI XXXXXXXXXXXXX0215
ZPIZAMERICAN AIR ELECTRONIC TICKET NUMBER IS 0017613251330
ZPIZINVOICE NUMBER IS 006372
ZPIZSERVICE FEE***** (b)(4) *****
ZPIZTICKETED FARE***** (b)(4) *****
ZPIZTOTAL CHARGE*****\$341.91
CB/CGEBILLING/ATRS/2020-09-15T13.25.00Z

ZPIZAMERICAN AIR TICKET WAS CHARGED TO VI XXXXXXXXXXXXX0215
ZPIZAMERICAN AIR ELECTRONIC TICKET NUMBER IS 0017613729825
ZPIZINVOICE NUMBER IS 006373
ZPIZSERVICE FEE***** (b)(4) *****
ZPIZTICKETED FARE***** (b)(4) *****
ZPIZTOTAL CHARGE*****\$276.81
CB/CGEBILLING/ATRS/2020-09-15T13.34.00Z

DUE TO RECENT CHANGES IN THE GOV CITY PAIR PROGRAM
YOUR AIR RESERVATIONS ARE SUBJECT TO CANCELLATION
BY THE AIRLINES IF NOT TICKETED AT LEAST 48 HOURS
PRIOR TO SCHEDULED DEPARTURE. PLEASE ENSURE ALL
NECESSARY APPROVALS ARE PROCESSED IN ACCORDANCE
WITH YOUR AGENCYS BUSINESS RULE BUT NO LESS THAN 3
BUSINESS DAYS PRIOR TO DEPARTURE. THIS 48 HOUR
CANCELLATION RULE DOES NOT APPLY TO YOUR
INTERNATIONAL RESERVATIONS UNLESS YOUR TRIP HAS
DOMESTIC CONNECTIONS ON MORE THAN ONE AIRLINE OR
THESE RESERVATIONS WILL REQUIRE SEPARATE TICKETS.

1010O5899
1010O5899

**For travel agent assistance and emergencies, please call 1-877-813-5900.

Your TMC Code is "11T" Duluth Travel

New TSA guidelines

<https://www.tsa.gov/news/releases/2019/04/04/tsa-reminds-travelers-real-id-identification-requirements>

Document Header Information

Document Type: Voucher Document Name: VCH21001820
 Travel Authorization Number: 101005928 Trip Name: Florida, California, Montana
 TA Date: 10/07/20 Currency: USD
 Organization: VAVACO 101 OFFICE OF THE SECRETARY Current Status: CREATED
 Purpose: SITE VISIT Document Detail: Site visits in Miami, FL; Long Beach and Riverside, CA; Billings, Helena/Fort Harrison, Missoula, and Kalispell, MT.
 Type Code: REGULAR TDY

Traveler Profile

Name: WILKIE, ROBERT L ID: (b)(6)
 TID: (b)(6) Organization: VAVACO 101 OFFICE OF THE SECRETARY
 Title: SECRETARY OF VETERANS Duty Station: Washington, DC
 Security Cl: Card: IBA HLDR NON EXEMPT
 Office Address: 810 Vermont Ave NW
 Washington, DC 20420 EMAIL: (b)(6)@va.gov
 Office Phone: (b)(6) Cell Phone:
 Home Address: Home Phone:
 Alternate Address: Alternate Phone:

Document Information

Trip Number: 1
 Purpose: Site visits in Miami, FL; Long Beach and Riverside, CA; Billings, Helena/Fort Harrison, Missoula, and Kalispell, MT.

Itinerary Locations

From	To	Itinerary Location	Purpose	Per Diem Rates
09/23/20	09/24/20	MIAMI, FL	SITE VISIT	119.00 / 66.00
09/24/20	09/25/20	RIVERSIDE, CA	SITE VISIT	107.00 / 66.00
09/25/20	09/26/20	BILLINGS, MT	SITE VISIT	96.00 / 55.00
09/26/20	09/28/20	HELENA, MT	SITE VISIT	103.00 / 66.00
09/28/20	09/29/20	KALISPELL, MT	SITE VISIT	96.00 / 61.00

Document Totals

Total Expenses: 4,093.68
 Reimbursable Expenses: 1,066.94
 Non-Reimbursable Expenses: 3,026.74
 Advance Applied: .00
 Net to Traveler: 110.61
 Net to Government: 3,026.74
 Pay to Charge Card: 956.33

Document Totals by Expense Category

Expense Category	Cost	Advance Amount
Com. Carrier	3,012.24	.00
Lodging-Per Diem	657.69	.00
M&IE-Per Diem	409.25	.00
Transxn Fees	14.50	.00
Total Expenses:	4,093.68	.00

Trip 1 Details

Expenses					
Trip#: 1	Total Non-Per Diem Expenses:		3,083.43	Total Per Diem Expenses:	1,010.25
Date	Description	Category	Cost	Pay Method	Per Diem

09/23/2020	Airline Flight	Com. Carrier	3,012.24	CBA	
09/23/2020	Lodging	Lodging-Per Diem	96.00	IBA	*
09/23/2020	Hotel Taxes	Lodging-Per Diem	12.35	IBA	
09/23/2020	M&IE	M&IE-Per Diem	49.50	OTHER	*
09/23/2020	Government Vehicle	Transportation	.00	OTHER	
09/24/2020	Lodging	Lodging-Per Diem	107.00	IBA	*
09/24/2020	Hotel Taxes	Lodging-Per Diem	14.18	IBA	
09/24/2020	M&IE	M&IE-Per Diem	66.00	OTHER	*
09/24/2020	Government Vehicle	Transportation	.00	OTHER	
09/25/2020	Lodging	Lodging-Per Diem	96.00	IBA	*
09/25/2020	Hotel Taxes	Lodging-Per Diem	9.68	IBA	
09/25/2020	M&IE	M&IE-Per Diem	55.00	OTHER	*
09/25/2020	Government Vehicle	Transportation	.00	OTHER	
09/26/2020	Lodging	Lodging-Per Diem	103.00	IBA	*
09/26/2020	Hotel Taxes	Lodging-Per Diem	10.24	IBA	
09/26/2020	M&IE	M&IE-Per Diem	66.00	OTHER	*
09/26/2020	Government Vehicle	Transportation	.00	OTHER	
09/27/2020	Lodging	Lodging-Per Diem	103.00	IBA	*
09/27/2020	Hotel Taxes	Lodging-Per Diem	10.24	IBA	
09/27/2020	M&IE	M&IE-Per Diem	66.00	OTHER	*
09/27/2020	Government Vehicle	Transportation	.00	OTHER	
09/28/2020	Lodging	Lodging-Per Diem	96.00	IBA	*
09/28/2020	M&IE	M&IE-Per Diem	61.00	OTHER	*
09/28/2020	Government Vehicle	Transportation	.00	OTHER	
09/29/2020	M&IE	M&IE-Per Diem	45.75	OTHER	*
09/29/2020	Government Vehicle	Transportation	.00	OTHER	
10/07/2020	TDY Voucher Fee	Transxn Fees	14.50	CBA	

Per Diem Allowances

Trip#: 1 Total Per Diem Allowances: 1,010.25

Date	Rate	Ldg Cost	Ldg Allowed	M&IE Cost	M&IE Allowed	B L D Conf%
09/23/2020	119.00/ 66.00	96.00	96.00	49.50	49.50	
09/24/2020	107.00/ 66.00	107.00	107.00	66.00	66.00	
09/25/2020	96.00/ 55.00	96.00	96.00	55.00	55.00	
09/26/2020	103.00/ 66.00	103.00	103.00	66.00	66.00	
09/27/2020	103.00/ 66.00	103.00	103.00	66.00	66.00	
09/28/2020	96.00/ 61.00	96.00	96.00	61.00	61.00	
09/29/2020	96.00/ 61.00	0.00	0.00	45.75	45.75	

Advance of Funds

Cannot print default advance form.
Unable to find an other authorization for cash advance.

Account Summary for the Selected Trip

Org: VAVACO 101 OFFICE OF THE SECRETARY Label: VA VACO 101 OSVA Acct Code: 000000A0011010004 0142A1101 20/2172 4,093.68			
Expense Category: Com. Carrier	Fiscal Year: 2020	Amount: 3,012.24	
Expense Category: Lodging-Per Diem	Fiscal Year: 2020	Amount: 657.69	
Expense Category: M&IE-Per Diem	Fiscal Year: 2020	Amount: 409.25	
Expense Category: Transxn Fees	Fiscal Year: 2020	Amount: 14.50	
Total:			4,093.68

Payment Detail Information

Organization	Label	Accounting String	Payment Method	Amount
VAVACO 101 OFFICE OF THE SECRETARY	VA VACO 101 OSVA	000000A0011010004 0142A1101 20/2172	CBA	3,026.74
VAVACO 101 OFFICE OF THE SECRETARY	VA VACO 101 OSVA	000000A0011010004 0142A1101 20/2172	IBA	657.69
VAVACO 101 OFFICE OF THE SECRETARY	VA VACO 101 OSVA	000000A0011010004 0142A1101 20/2172	OTHER	409.25

Totals by Label

VAVACO 101 OFFICE OF THE SECRETARY	VA VACO 101 OSVA	Total	000000A0011010004 0142A1101 20/2172	4,093.68
------------------------------------	------------------	-------	-------------------------------------	----------

Totals by Payment Method

CBA Total	3,026.74
IBA Total	657.69

Attachments

Attachments Exist

Receipt Checklist

Date	Description	Cost
09/23/20	AIR Airline Flight	\$3,012.24
09/23/20	Lodging	\$96.00
09/23/20	Hotel Taxes	\$12.35
09/24/20	Lodging	\$107.00
09/24/20	Hotel Taxes	\$14.18
09/25/20	Lodging	\$96.00
09/25/20	Hotel Taxes	\$9.68
09/26/20	Lodging	\$103.00
09/26/20	Hotel Taxes	\$10.24
09/27/20	Lodging	\$103.00
09/27/20	Hotel Taxes	\$10.24
09/28/20	Lodging	\$96.00

Audits

Audit Name	Result	Reason
COST COMPARISON	FAIL	Voucher COST (TRIP 1) IS NOT WITHIN 25% OF COST (TA20133183) Voucher cost is more than 125% greater than total estimated cost from Travel Authorization. Justification is required.
	Traveler Justification:	Flights changed during TDY and the cost increased.

Document History 10/07/2020 Voucher: VCH21001820

Copyright 1989-2009 Concur Government Edition: Concur Inc. WILKIE, ROBERT L. (b)(6)

STATUS	DATE	TIME	SIGNATURE NAME	REASON
CREATED	10/07/2020	6:21AM EST	(b)(6)	

I certify that the electronic signatures listed above are valid and on file

(b)(6) SIGNED DATE: 10/7/2020

I certify this claim is true and correct to the best of my knowledge and belief, and that payment or credit has not been received by me or the traveler (if signed by alternate representative). I understand there are severe criminal and civil penalties for knowingly submitting a false, fictitious or fraudulent claim (18 U.S.C. Sections 287 and 1001, and 31 U.S.C. Section 3729)

Document Signatures

Traveler/Preparer Name:

Traveler/Preparer Signature:

Date:

Approver Name:

Approver Signature:

Date:

Robert Wilkie

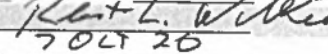

7 OCT 20

FOR OFFICIAL USE ONLY – DO NOT DISTRIBUTE
FINAL 9

THE HONORABLE ROBERT WILKIE
SECRETARY OF VETERANS AFFAIRS
TRAVEL ITINERARY

MIAMI, FL – LONG BEACH, CA – RIVERSIDE, CA - BILLINGS, MT – HELENA/FORT
HARRISON, MT – MISSOULA, MT – KALISPELL, MT
SEPTEMBER 23-29, 2020

TRAVELING PARTY:

The Honorable Robert Wilkie
Jon Rychalski, Assistant Secretary for Management and Chief Financial Officer (*Helena & Kalispell Only*)
Michael Meador, Special Assistant to the Secretary
Traci Scott, Senior Advisor for Strategic Communications
Christopher Anderson, Senior Advisor, OCLA

(b)(6)

EXECUTIVE PROTECTION:

(b)(6); (b)(7)(C) Special Agent (DL)
(b)(6); (b)(7)(C) Special Agent (Adv-Miami)
(b)(6); (b)(7)(C) Special Agent (Adv-CA)
(b)(6); (b)(7)(C) Special Agent (Adv-MT)
(b)(6); (b)(7)(C) Special Agent (MT)
(b)(6); (b)(7)(C) Special Agent (MT)

(b)(6); (b)(7)(C)

EVENT / SITE POCs:

Mary Kay Rutan, VA Sunshine Healthcare Network (VISN 8-Miami)
Shane Suzuki, Public Affairs, Miami VAMC
Timothy Vermillion, Director, Miami Vet Center
(b)(6), Health Systems Specialist, Long Beach VAHCS
Gina Farrisee, Executive Director, National Cemetery Administration
(b)(6), Congressional Liaison, Montana VA Health Care System
Anton Johnson, Readjustment Counselor Tech, Missoula Vet Center
Adam Jones, Veteran Outreach Program Specialist, Kalispell Vet Center
(b)(6), Director, Denver OPIA
(b)(6), PA Specialist, Denver OPIA

(b)(6)

SCHEDULING POCs:

Albert Guerrero, Travel Coordinator, OSVA (Adv-Miami)
Matt Webb, Special Assistant, OSVA (Adv-CA)
Chelsea Childress, Special Assistant, OSVA (Adv-MT)
(b)(6) Travel Coordinator, OSVA
(b)(6) Travel Coordinator, OSVA

(b)(6)

**FOR OFFICIAL USE ONLY – DO NOT DISTRIBUTE
FINAL 9**

Wednesday, September 23, 2020

Attire: Business

Weather:	Washington, DC	H-81°; L-55° - Sunny
	Miami, FL	H-87°; L-72° - Partly Cloudy

0545-0600 ERT / ARRIVE WASHINGTON REAGAN NATIONAL AIRPORT *15 min*)

1 Aviation Circle, Arlington, VA

Drive time: 15 min / 3.6 miles

0658 WHEELS UP MIAMI INTERNATIONAL AIRPORT (MIA)

American Airlines 391, DCA-MIA, 0658-0934, Nonstop

Total Travel Time: 2 hr 36 min

0934 WHEELS DOWN MIAMI INTERNATIONAL AIRPORT (MIA)

2100 NW 42ND Ave, Miami, FL 33126

0950-1010 ERT / ARRIVE MIAMI VA HEALTHCARE SYSTEM *(20 min)*

1201 N.W. 16th St. Miami, FL 33125

Drive Time: 20 min / 7.2 miles

Greeted by:

- Dr. Miguel LaPuz, Director, VISN 8
- Ms. Kalautie JangDhari, Director, Miami VA Healthcare System

1010-1020 INTRODUCTION TO COVID-19 ENTRANCE SCREENING AREA *(10 min)*

All patients and staff are screened before entry with a temperature check and a questionnaire.

The questionnaire can be completed on your smartphone, by texting “screen” to 53079, clicking <https://www.va.gov/covid19screen/> or using the QR code below.



If you choose to not use the online screening questionnaire, you will be screened in person by being asked a series of basic questions about your current health status.

If anyone answers yes to any of the screening questions, or has a fever, will be referred to secondary screening conducted by a health care provider.

**FOR OFFICIAL USE ONLY – DO NOT DISTRIBUTE
FINAL 9**

1020-1120 LEADERSHIP BRIEFING (1 hr)

Location: Director's Conference Room

Topics:

- Miami VA COVID Response
- Miami VA Moving Forward Plan
- General Miami VA Update
 - Veteran Suicide Prevention
 - Art Therapy

Attendees: (14)

- The Honorable Robert Wilkie
- Michael Meador, Special Assistant to the Secretary
- Traci Scott, Senior Advisor for Strategic Communications
- Chris Anderson, Senior Advisor, Office of Congressional and Legislative Affairs
- Dr. Miguel LaPuz, Director, VISN 8
- Ms. Kalautie JangDhari, Director, Miami VAHS
- Dr. Vincent DeGennaro, Chief of Staff, Miami VAHS
- Mr. Froy Garza, Associate Director, Miami VAHS
- Dr. Marilly Cadavid, Associate Director for Patient Care Services (interim), Miami VAHS
- Ms. Raquel Bulford-Frazier, Assistant Director, Miami VAHS
- Dr. (b)(6) Chief of Infectious Disease Section, Miami VAHS and VISN 8
- Dr. (b)(6), Suicide Prevention Coordinator, Miami VAHS
- Ms. (b)(6) Chief, Recreation Therapy, Miami VAHS
- Dr. (b)(6) Chief, Mental Health, Miami VAHS

1120-1135 COIN RECOGNITION (15 min)

Location: Director's Conference Room*

Recipients: (8)

- Ms. (b)(6) RN, Nurse Manager of Emergency Department
- (b)(6) Environmental Management Service, CLC, Miami VAHS
- Ms. (b)(6) Chief Occupational Health, Miami VAHS
- Mr. (b)(6) RN, CLC, Miami VAHS
- Ms. (b)(6) RN, CLC, Miami VAHS
- Dr. (b)(6) Chief of Infectious Disease Section, Miami VAHS and VISN 8
- Dr. Vincent DeGennaro, COS, Miami VAHS
- Ms. (b)(6) Gold Star (b)(6) of Bruce W. Carter, Medal of Honor Recipient and VA Medical Center's namesake; former president of the American Gold Star Mothers; and multi-decade volunteer. *In Director's Office

1135-1140 EXECUTIVE TIME (5 min)

1140-1225 FACILITY TOUR (45 min)

**FOR OFFICIAL USE ONLY – DO NOT DISTRIBUTE
FINAL 9**

Tour Led By:

- Ms. Kalautie JangDhari, Director Miami VAHS,
- Dr. Miguel LaPuz, Director VISN 8
- Shane Suzuki, Miami VAHS PAO

Highlighted Areas:

- New VCS Canteen
- COVID Renovations in Emergency Department

1230-1245 ERT / ARRIVE LUNCH (15 min)

1245-1315 LUNCH (30 min)

1315-1335 ERT / ARRIVE MIAMI VET CENTER (20 min)

8280 NW 27th St #511, Doral, FL 33122

Drive Time: 20 min / 7 miles

Greeted by: Dr. Timothy Vermillion, Director

1340-1345 MEDIA PREP (5 min)

Location: Director's Office

1345-1400 MEDIA AVAILABILITY (15 min)

Location: Director's Office

Interview: (Zoom call)

- WTVJ (NBC, Miami); Reporter: Jackie Nespral

1405-1425 FACILITY TOUR (20 min)

Tour Led By: Dr. Timothy Vermillion, Director

Highlighted Areas:

- Large Group Room
- Work Center

1430-1440 COIN RECOGNITION (10 min)

Location: Large Group Room

Recipients: (5)

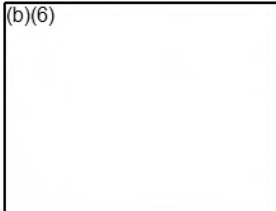
- (b)(6)
- 
-
-
-
-

1445-1505 ERT / ARRIVE MIAMI AIRPORT MARRIOTT (20 min)

1201 NW, S Le Jeune Rd Bldg A, Miami, FL 33126

**FOR OFFICIAL USE ONLY – DO NOT DISTRIBUTE
FINAL 9**

Drive Time: 20 min / 6 miles

RON

Thursday, September 24, 2020		Attire: Business
Weather:	Miami, FL	H-89°; L-74° - Partly Cloudy
	Long Beach, CA	H-81°; L-64° - Partly Cloudy
	Riverside, CA	H-93°; L-62° - Sunny

0710-0715 ERT / ARRIVE MIAMI INTERNATIONAL AIRPORT (MIA) (5 min)

2100 NW 42ND Ave, Miami, FL 331267

Drive Time: 5 min / 1.5 miles

0715-0755 EXECUTIVE TIME (40 mins)

0755-0835 GATE TRANSITION / BOARDING (40 min)

0835 WHEELS UP TO LOS ANGELES INTERNATIONAL AIRPORT (LAX)

American Airlines 1228 MIA-LAX 0835-1103, 5 hr 28 min

Total travel time: 5 hr 28 min

1103 WHEELS DOWN ANGELES INTERNATIONAL AIRPORT (LAX)

1 World Way, Los Angeles, CA 90045

1130-1200 ERT / ARRIVE LUNCH LOCATION (30 min)

Drive Time: TBD min / TBD miles

1200-1230 LUNCH (30 min)

1230-1315 VA LONG BEACH HEALTHCARE SYSTEM (45 min)

5901 East 7th Street, Building 150, SCI Long Beach, CA

Drive Time: 45 min / 26.4 miles

Greeted By:

Walt Dannenberg, Medical Center Director

Michael Fisher, VISN 22 Network Director

Rich Beam, Public Affairs Officer

(b)(6) Health Systems Specialist

1315-1320 INTRODUCTION TO COVID-19 ENTRANCE SCREENING AREA(5 min)

Location: Bldg. 150, Spinal Chord Injury Unit

All patients and staff are screened before entry with a temperature check and a questionnaire.

Updated by: Chelsea Childress

Mission Operations

9/24/2020 1:52 PM

**FOR OFFICIAL USE ONLY – DO NOT DISTRIBUTE
FINAL 9**

The questionnaire can be completed on your smartphone, by texting “screen” to 53079, clicking <https://www.va.gov/covid19screen/> or using the QR code below.



If you choose to not use the online screening questionnaire, you will be screened in person by being asked a series of basic questions about your current health status.

If anyone answers yes to any of the screening questions, or has a fever, will be referred to secondary screening conducted by a health care provider.

1325-1410 LEADERSHIP BRIEFING (45 min)

Location: Bldg. 164, Learning Center

Topics:

- Lean Transformation and High Reliability Organization
- COVID-19 Response
- Stellate Ganglion Block (SBG) and Veteran Mental Evaluation Team (VMET)
- Construction

Attendees:

- The Honorable Robert Wilkie, Secretary of Veterans Affairs
- Michael Meador, Special Assistant to the Secretary
- Traci Scott, Senior Advisor for Strategic Communications
- Christopher Anderson, Special Assistant, OCLA
- Mr. Michael Fisher, Network Director
- Mr. Walt Dannenberg, Medical Center Director
- Mr. Bryan Arnette, Acting Associate Director
- Dr. Elizabeth Aubry, Chief of Staff
- Dr. (b)(6) Deputy Chief of Staff
- Mr. Cory Ramsey, Associate Director Of Patient Care Services
- Dr. Marla Weiss, Deputy Associate Director of Patient Care Services
- Ms. Michelle Harkey, Acting Assistant Director
- Mr. Richard Beam, Public Affairs Officer
- Mr. (b)(6), Health System Specialist (GHATP)
- Ms. (b)(6) Health System Specialist

1410-1420 COIN RECOGNITION (10 min)

Location: Bldg. 164, Learning Center

Recipients: (6)

**FOR OFFICIAL USE ONLY – DO NOT DISTRIBUTE
FINAL 9**

- (b)(6) (Acting Disaster Emergency medical Personnel System (DEMPS) Coordinator)
- Mr. (b)(6) (Chief of Logistics)
- Mr. (b)(6) (COVID-19 Hospital Incident Command Planner)
- Dr. (b)(6) (Nursing Supervisor, Infectious Prevention)
- Dr. (b)(6) (Infection Prevention)
- Mr. (b)(6) (Chief of Engineering)

1420-1425 EXECUTIVE TIME (5 min)

1425-1430 MEDIA PREP (5 min)

Location: Bldg 164, BRC Conference Room F109

1430-1455 MEDIA AVAILABILITY (25 min)

Location: 126 South Lawn off Parking Lot B
TV Interview: KCAL(CBS, Los Angeles)

1500-1545 FACILITY TOUR (45 min)

Tour Led By: Mr. Rich Beam, Public Affairs Officer
Highlighted Areas:

- Mobile Medical Hospital
- Spinal Cord Injury Unit
- Major Charles Soltes Mural at the Blind Rehab Center

1545-1715 ERT / ARRIVE MARRIOTT RIVERSIDE CONVENTION CENTER (1 hr 30 min)

3400 Market Street, Riverside, CA 92501

Drive time: 1 hr 30 min / 52.9 miles

**Prep Call for Virtual MT. Tribal Officials Engagement @ 1600
SECVA to call (872) 701-0185, Conference ID: (b)(6) #*

Attendees:

The Honorable Robert L. Wilkie, Secretary of Veterans Affairs
Mr. Michael Meador, Special Assistant to the Secretary
Mr. Thayer Verschoor, Executive Director, IGA
Ms. Stephanie Birdwell, Director of Tribal Government Relations
Mr. (b)(6) Relations Specialist, IGA
Ms. Traci Scott, Senior Advisor for Strategic Communications
Mr. Christopher Anderson, Senior Advisor, OCLA
Ms. (b)(6), Director of Mission Operations, OSVA
Ms. Chelsea Childress, Special Assistant, OSVA
Mr. Ralph Gigliotti, VISN 19 Network Director
Ms. Sunaina Kumar, VISN 19 Deputy Network Director
Mr. (b)(6), VISN 19 Minority Program Manager
Ms. (b)(6), VISN 19 EA to the Network Director

**FOR OFFICIAL USE ONLY – DO NOT DISTRIBUTE
FINAL 9**

Dr. Judy Hayman, MTVAHCS Executive Director

RON

Friday, September 25, 2020	Attire: Business
Weather: Riverside, CA	H-91°; L-61° - Sunny
Billings, MT	H-81°; L-54° -Partly Cloudy

0715-0720 MEDIA PREP (5 min)

Location:

0720-0745 MEDIA AVAILABILITY (25 min)

Radio Interview:

Location:

0745-0810 BREAKFAST ON OWN (30 min)

0810-0830 ERT / ARRIVE RIVERSIDE NATIONAL CEMETERY (20 min)

22495 Van Buren Boulevard, Riverside, CA 92518

Drive time: 20 min / 12 miles

Greeted by:

Randy Reeves, USMA,

Gina Farrissee, NCA Executive Director,

(b)(6) Cemetery Director,

0830-0845 EXECUTIVE TIME (15 min)

0845-1000 AMERICAN INDIAN VETERANS MEMORIAL GROUNDBREAKING CEREMONY

(1 hr 15 min)

Run of Show:

- 0845-0900: Indian Hill Drummers & Dancers (Pre-Ceremony performance)
- 0900-0905: Introduction of Guests
 - *Location: Ceremony location – POW/MIA Memorial*
 - *Master of Ceremonies-*(b)(6)
- 0905-0908: National Anthem
 - *Participants:* (b)(6) *Chairperson of Indian Veterans Committee*
- 0908-0912: Opening Blessing
 - *Participant* (b)(6)
- 0912-0914: RNC Directors welcome & introduction of Native American Speaker
 - *Participant:* (b)(6)
- 0914-0919: Native American Speaker
 - *Participant: TBD*
- 0919-0921: Introduction of USMA
 - *Participant:* (b)(6)
- 0921-0926: USMA

**FOR OFFICIAL USE ONLY – DO NOT DISTRIBUTE
FINAL 9**

- *Participant: USMA*
- 0926-0928: Introduction of Keynote Speaker
 - *Participant: USMA*
- 0928-0935: Keynote Speaker
 - *Participant: SECVA*
- 0935-0959: Groundbreaking
 - *Participants: TBD*

Location: NAI Memorial Site

Note: Ushers will lead participants to site, (b)(6) will announce for all attendees to remain in their seats until Official Party departs.

- 0959 – 1000: Ceremony End Announcement
 - *Participant: (b)(6) RNCSC*

1005-1045 ERT / ARRIVE LUNCH LOCATION

1045-1145 LUNCH

1145-1200 ERT/ARRIVE ONTARIO INTERNATIONAL AIRPORT (ONT) (15 mins)
2500 E Airport Dr Ontario, CA 91761

1200-1240 GATE TRANSITION / AIRCRAFT BOARDING (40 min)

1240 WHEELS UP TO BILLINGS LOGAN INTERNATIONAL AIRPORT (BIL)
American Airlines 2945 ONT-DFW 1240-1737, 2 hr 57 min
Layover at DFW: 1 hr 23 min
American Airlines 4247 DFW-BIL 1900-2052, 2 hr 52 min
Total travel time: 7 hr 12 min

2052 WHEELS DOWN TO BILLINGS LOGAN INTERNATIONAL AIRPORT (BIL)
1901 Terminal Circle, Billings, MT 59105

2112-2129 ERT / ARRIVE HILTON GARDEN INN BILLINGS (17 mins)
2465 Grant Rd, Billings, MT 59102
Drive time: 17 min / 6.3 miles

RON

**FOR OFFICIAL USE ONLY – DO NOT DISTRIBUTE
FINAL 9**

Saturday, September 26, 2020

Attire: Business

Weather: Billings, MT H-74°; L-50° - Mostly Sunny
Helena/Fort Harrison, MT H-69°; L-46° - Partly Cloudy

0900-1000 VIRTUAL MT TRIBAL OFFICIALS ENGAGEMENT (1 hr)

Location: Hilton Garden Inn Billings, Columbus Board Room

Meeting Link (with camera): [Join Microsoft Teams Meeting](#)

Join by phone (no camera): 872-701-0185 Conference ID: (b)(6)

Engagement Moderated By: Mr. (b)(6) VISN 19 Minority Program Manager

Agenda:

- Opening Prayer
- Introductions:
 - Ms. Stephanie Birdwell, Director of Tribal Government Relations
 - Mr. (b)(6) VISN 19 Minority Program Manager
- Opening Remarks
 - Honorable Robert L. Wilkie, Secretary of Veterans Affairs
- Discussion/Questions:
 - Moderated By: Mr. (b)(6) VISN 19 Minority Program Manager
 - Tribal Officials
- Closing Remarks
 - Honorable Robert L. Wilkie, Secretary of Veterans Affairs

Attendees: (23)

- The Honorable Robert L. Wilkie, Secretary of Veterans Affairs (In-Person)
- Mr. Michael Meador, Special Assistant to the Secretary (In-Person)
- Ms. Traci Scott, Senior Advisor for Strategic Communications (In-Person)
- Mr. Christopher Anderson, Senior Advisor, OCLA (In-Person)
- Ms. Sunaina Kumar, VISN 19 Deputy Network Director (In-Person)
- Dr. Judy Hayman, MTVAHCS Executive Director (In-Person)
- Mr. (b)(6) VISN 19 Minority Program Manager (In-Person)
- (b)(6) VBA Tribal Outreach Supervisor (In Person)
- Koryn Van Elmeren, Acting VBA Director (Virtual)
- Mr. Thayer Verschoor, Executive Director, IGA (Virtual)
- Ms. Stephanie Birdwell, Director of Tribal Government Relations (Virtual)
- Mr. (b)(6) Relations Specialist, IGA (Virtual)
- Rocky Mountain Tribal Leaders Council, Billings, MT (Virtual)
- Crow Nation, Crow Tribal Executive Branch, Crow Agency, MT (Virtual)
- Northern Cheyenne Nation, Northern Cheyenne Tribal Council, Lame Deer, MT (Virtual)
- Assiniboine-Sioux Nation, Fort Peck Tribal Executive Board, Poplar, MT (Virtual)

**FOR OFFICIAL USE ONLY – DO NOT DISTRIBUTE
FINAL 9**

- Assiniboine/ Gros-Ventre Nation, Fort Belknap Indian Community Council, Harlem, MT (Virtual)
- Chippewa Cree Nation, Chippewa Cree of Rocky Boy Executive Branch, Box Elder, MT (Tentative) (Virtual)
- Little Shell Tribe of Chippewa Indians of Montana, Little Shell Tribe, Great Falls, MT (Tentative) (Virtual)
- Blackfeet Nation, Blackfeet Tribal Business Council, Browning, MT (Tentative) (Virtual)
- Piikani Nation, Piikani Nation Administration, Brocket, AB (Tentative) (Virtual)
- Flathead Nation, Confederated Salish & Kootenai Tribal Council, Pablo, MT (Virtual)
- Shoshone-Bannock Tribes, Fort Hall Business Council, Fort Hall, ID (Tentative) (Virtual)
- Eastern Shoshone Nation, Eastern Shoshone Business Council, Ft Washakie, WY (Virtual)
- Northern Arapaho Nation, Northern Arapaho Business Council, Ft Washakie, WY (Tentative) (Virtual)
- Helena Indian Alliance of Montana, Helena, MT (Tentative) (Virtual)

1000-1100 EXECUTIVE TIME (1 hr)

1100-1110 ERT / ARRIVE LUNCH LOCATION (10 min)

1110-1210 LUNCH (1 hr)

1210-1550 ERT / ARRIVE DOUBLETREE BY HILTON HELENA DOWNTOWN (4 hr 40 min)

22 North Last Chance Gulch, Helena, MT 59601

Drive time: 3 hr 40 min / 231 miles

RON

Sunday, September 27, 2020

Attire: Casual

Weather: Helena/Fort Harrison, MT H-69°; L-47° - Partly Cloudy

TBD TBD

DOUBLETREE BY HILTON HELENA DOWNTOWN

22 North Last Chance Gulch, Helena, MT 59601

RON

**FOR OFFICIAL USE ONLY – DO NOT DISTRIBUTE
FINAL 9**

Monday, September 28, 2020

Attire: Business

Weather:	Helena/Fort Harrison, MT	H-71°; L-45° - Partly Cloudy
	Missoula, MT	H-72°; L-44° - Partly Cloudy
	Kalispell, MT	H-71°; L-42° - Mostly Sunny

0745-0800 ERT / ARRIVE FORT HARRISON VA MEDICAL CENTER (15 min)

3687 Veterans Drive, Fort Harrison, MT 59636

Drive time: 15 min / 5.4 miles

Greeted by:

- Ms. Sunaina Kumar, VISN 19 Deputy Network Director
- Dr. Judy Hayman, MTVAHCS Executive Director

0800-0810 INTRODUCTION TO COVID-19 ENTRANCE SCREENING AREA (10 min)

Location: Honors Drive, Fort Harrison, MT 59636

All patients and staff are screened before entry with a temperature check and a questionnaire.

The questionnaire can be completed on your smartphone, by texting “screen” to 53079, clicking <https://www.va.gov/covid19screen/> or using the QR code below.



If you choose to not use the online screening questionnaire, you will be screened in person by being asked a series of basic questions about your current health status.

If anyone answers yes to any of the screening questions, or has a fever, will be referred to secondary screening conducted by a health care provider.

0810-0855 LEADERSHIP BRIEFING (45 min)

Location: Recreation Hall (1st Floor of the Hospital Building)

Topics:

- COVID-19 Response
- MTVAHCS Successes
- MTVAHCS Challenges

Attendees: (17)

- The Honorable Robert L. Wilkie, Secretary of Veterans Affairs
- Mr. Greg Gianforte, U.S. Representative for Montana (*Tentative*)
- Mr. Steve Daines, U.S. Senator for Montana

**FOR OFFICIAL USE ONLY – DO NOT DISTRIBUTE
FINAL 9**

- Mr. Jon Tester, U.S. Senator for Montana (*Tentative*)
- Mr. Jon Rychalski, Assistant Secretary for Management and Chief Financial Officer
- Mr. Michael Meador, Special Assistant to the Secretary
- Ms. Traci Scott, Senior Advisor for Strategic Communications
- Mr. Christopher Anderson, Senior Advisor, OCLA
- Ms. Chelsea Childress, Special Assistant, OSVA
- Ms. Sunaina Kumar, VISN 19 Deputy Network Director
- Dr. Judy Hayman, MTVAHCS Executive Director
- Dr. JP Maganito, MTVAHCS Chief of Staff
- Mr. Daniel Caufield, MTVAHCS Associate Director
- Ms. Vicki Thennis, Acting MTVAHCS Associate Director of Patient Care Services
- Mr. Michael Crouse, Fort Harrison Regional Office (VBA) Director
- Mr. (b)(6) VISN 19 Minority Program Manager
- Dr. (b)(6) MTVAHCS Chief Behavioral Health

0855-0905 COIN RECOGNITION (10 min)

Location: Recreation Hall (1st Floor of the Hospital Building)

Recipients: (4)

- (b)(6) MTVAHCS Emergency Manager
- (b)(6) MTVAHCS Pathology and Laboratory Supervisor
- (b)(6) Congressional Liaison
- (b)(6) RN MTVAHCS

0905-0910 EXECUTIVE TIME (5 min)

0910-0955 FACILITY TOUR (45 min)

Tour Led By:

- Ms. Sunaina Kumar, VISN 19 Deputy Network Director
- Dr. Judy Hayman, MTVAHCS Executive Director
- Ms. (b)(6) MTVAHCS Congressional Liaison

Highlighted Areas

- Campus Tour (Vehicle Tour)
- New Primary Care Building
- Primary Care and Emergency Department (1st Floor)
- New Employee Orientation (SECVA to provide 5-minute welcome)
- Canteen
- EMS Engagement (Main Lobby)

0955-1000 MEDIA PREP (5 min)

Location: Rec Hall

**FOR OFFICIAL USE ONLY – DO NOT DISTRIBUTE
FINAL 9**

1000-1020 MEDIA AVAILABILITY (20 min)

Location:

- Indoor: Rec Hall
- Outdoor: Front of Parade Ground

1030-1040 ERT / ARRIVE LUNCH LOCATION (10 min)

1040-1050 ORDER LUNCH (10 min)

1050-1245 ERT / ARRIVE MISSOULA VA CLINIC (1 hr 55 min)

2687 Palmer Street, Suite C, Missoula, MT 59808

Drive time: 1 hr 55 min

Greeted by:

- Dr. Judy Hayman, MTVAHCS Director
- Dr. JP Maganito, MTVAHCS Chief of Staff
- Mr. (b)(6) Clinic Manager

1245-1250 INTRODUCTION TO COVID-19 ENTRANCE SCREENING AREA (5 min)

Location: David J. Thatcher VA Clinic, foyer of the Primary Care building

All patients and staff are screened before entry with a temperature check and a questionnaire.

The questionnaire can be completed on your smartphone, by texting “screen” to 53079, clicking <https://www.va.gov/covid19screen/> or using the QR code below.



If you choose to not use the online screening questionnaire, you will be screened in person by being asked a series of basic questions about your current health status.

If anyone answers yes to any of the screening questions, or has a fever, will be referred to secondary screening conducted by a health care provider.

1250-1320 LEADERSHIP BRIEFING / FACILITY TOUR (30 min)

Tour Led By:

- Dr. Judy Hayman, MTVAHCS Director
- Dr. JP Maganito, MTVAHCS Chief of Staff
- Mr. (b)(6) Clinic Manager

**FOR OFFICIAL USE ONLY – DO NOT DISTRIBUTE
FINAL 9**

Highlighted Areas

- Call Center (2nd floor PT/BH Bldg)
- Physical Therapy/Behavioral Health (1st floor PT/BH Bldg)
- Primary Care Clinic (1st floor Primary Care Bldg)

Coin Recipient (1) (Will be done along tour route)

- Ms. (b)(6) Lead Charge Nurse

1320-1325 MEDIA PREP (5 min)
Location: Conference Room by Tele-Health

1325-1350 MEDIA AVAILABILITY (25 min)
Location:

- Outdoor: In front of Primary Care Building

1355-1410 ERT / ARRIVE MISSOULA VET CENTER (15 min)
910 Brooks Street, Missoula, MT 59801
Drive time: 15 min / 3.3 miles
Greeted by:

- Ms. Meaghan Lee-Moriarity, Missoula Vet Center Director (Tentative)
- Anton Johnson, Readjustment Counselor Tech, Missoula Vet Center

1415-1435 FACILITY TOUR (20 min)
Tour Led By:

- Ms. Meaghan Lee-Moriarity, Missoula Vet Center Director (Tentative)

1440-1710 ERT / ARRIVE HOMEWOOD SUITES BY HILTON KALISPELL (2 hr 30 min)
195 Hutton Ranch Rd, Kalispell, MT 59901
Drive time: 2 hr 30 min / 122 miles

RON

Tuesday, September 29, 2020

Attire: Business

Weather:	Kalispell, MT	H-73°; L-44° - Sunny
	Washington, DC	H-77°; L-59° - AM Showers

0825-0830 ERT / ARRIVE KALISPELL VA CLINIC (5 min)
31 Three Mile Dr. Suite 102, Kalispell, MT 59901
Drive time: 5 min / 1.8 miles
Greeted by:

- Dr. Judy Hayman, MTVAHCS Director
- Dr. JP Maganito, MTVAHCS Chief of Staff
- Ms. (b)(6) Clinic Manager

Updated by: Chelsea Childress
Mission Operations
9/24/2020 1:52 PM

**FOR OFFICIAL USE ONLY – DO NOT DISTRIBUTE
FINAL 9**

0830-0835 INTRODUCTION TO COVID-19 ENTRANCE SCREENING AREA (5 min)

Location: Main Clinic Entrance

All patients and staff are screened before entry with a temperature check and a questionnaire.

The questionnaire can be completed on your smartphone, by texting “screen” to 53079, clicking <https://www.va.gov/covid19screen/> or using the QR code below.



If you choose to not use the online screening questionnaire, you will be screened in person by being asked a series of basic questions about your current health status.

If anyone answers yes to any of the screening questions, or has a fever, will be referred to secondary screening conducted by a health care provider.

0835-0905 LEADERSHIP BRIEFING / FACILITY TOUR (30 min)

Tour Led By:

- Dr. Judy Hayman, MTVAHCS Director
- Dr. JP Maganito, MTVAHCS Chief of Staff
- Ms. (b)(6) Clinic Manager

Highlighted Areas

- Primary Care
- Behavioral Health

Coin Recipient (1) (Will be done along tour route)

- (b)(6) MSA Lead

0905-0910 MEDIA PREP (5 min)

Location: Clinic Manager’s Office (Office 11)

0910-0935 MEDIA AVAILABILITY (25 min)

Location:

- Outdoor: Side of VA Clinic Building

0940-0945 ERT / ARRIVE KALISPELL VET CENTER (5 min)

690 North Meridian Road, Suite 101, Kalispell, MT 59901

Drive time: 5 min / .5 miles

Greeted by:

- Ms. (b)(6), LCSW, Kalispell Vet Center Director

**FOR OFFICIAL USE ONLY – DO NOT DISTRIBUTE
FINAL 9**

- 0950-1010 FACILITY TOUR (20 min)**
Tour Led By: Ms. (b)(6) LCSW, Kalispell Vet Center Director
- 1010-1100 EXECUTIVE TIME (50 min)**
- 1100-1105 ERT / ARRIVE LUNCH LOCATION (5 min)**
Drive time: 5 min
- 1105-1130 LUNCH (25 min)**
- 1130-1145 ERT / ARRIVE GLACIER PARK INTERNATIONAL AIRPORT (15 min)**
4170 US-2, Kalispell, MT 59901
Drive time: 15 min / 9.7 miles
- 1145-1200 EXECUTIVE TIME (15 min)**
- 1200-1230 AIRCRAFT BOARDING (30 min)**
- 1230 WHEELS UP TO REAGAN NATIONAL AIRPORT (DCA)**
American Airlines 2922 FCA-DFW 1230-1655, 3 hr 25 min
Layover at DFW: 1 hr 55 min
American Airlines 2752 DFW-DCA 1850-2250, 3 hr 0 min
Total travel time: 8 hr 20 min
- 2250 WHEELS DOWN TO REAGAN NATIONAL AIRPORT (DCA)**
- 2305 ERT / ARRIVE RESIDENCE (15 min)**
Drive time: 15 min / 16.7 miles

MC

**FOR OFFICIAL USE ONLY – DO NOT DISTRIBUTE
FINAL 9**

TOTAL TIME BY LOCATION:

Fort Harrison VA Medical Center	2 hr 25 min
Missoula VA Clinic	35 min
Missoula Vet Center	20 min
Kalispell VA Clinic	35 min
Kalispell Vet Center	20 min

MAPS

Day 1 (Miami)



Day 2 (Miami)



**FOR OFFICIAL USE ONLY – DO NOT DISTRIBUTE
FINAL 9**

Billings, MT



Helena/Fort Harrison, MT



Missoula, MT



Kalispell, MT



LOCATION(S)

DRIVE TIME

MILES

Billings Logan International Airport – Hilton Garden Inn Billings	17 min	6.3 miles
Hilton Garden Inn Billings – Lunch Location	10 min	TBD
Lunch Location – DoubleTree Helena	3 hr 40 min	231 miles
DoubleTree Helena – Fort Harrison VA Medical Center	15 min	5.3 miles
Fort Harrison VA Medical Center – Lunch Location	10 min	TBD
Lunch Location – Missoula VA Clinic	20 min	TBD
Missoula VA Clinic – Missoula Vet Center	15 min	3.3 miles
Missoula Vet Center – Homewood Suites Kalispell	2 hr 30 min	122 miles
Homewood Suites Kalispell – Kalispell VA Clinic	5 min	1.8 miles
Kalispell VA Clinic – Kalispell Vet Center	5 min	.5 miles
Kalispell Vet Center – Lunch Location	TBD	TBD
Lunch Location – Glacier Park International Airport	22 min	10 miles

MOTORCADE LOAD PLAN

FOR OFFICIAL USE ONLY – DO NOT DISTRIBUTE
FINAL 9

23-24 September 2020 (Miami, FL)

ALL MOVEMENTS:

LIMO:

CHASE:

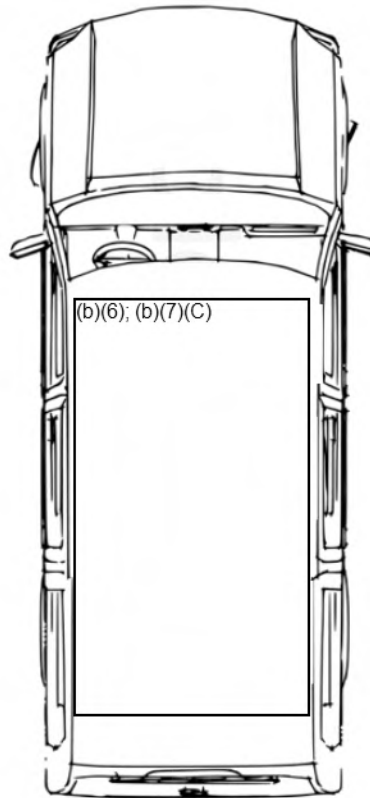
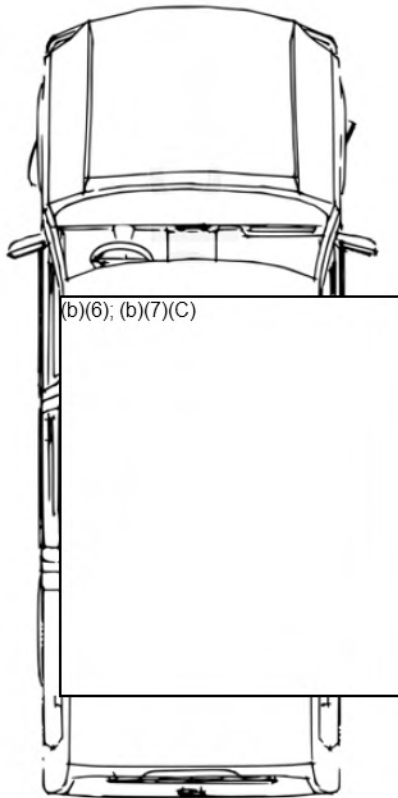

MOTORCADE LOAD PLAN

**FOR OFFICIAL USE ONLY – DO NOT DISTRIBUTE
FINAL 9**

24-25 September 2020 (Long Beach-Riverside, CA)

ALL MOVEMENTS:

LIMO:

CHASE:

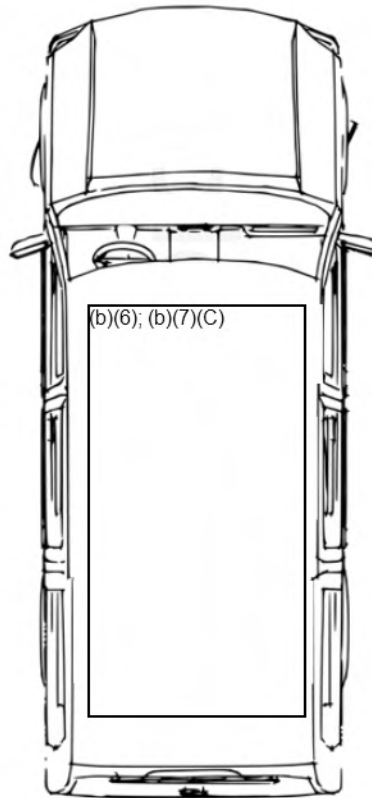
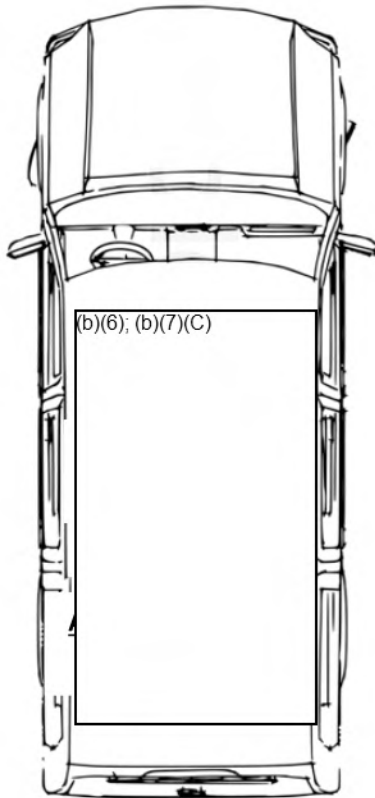

SEPTEMBER 25-27, 2020

FOR OFFICIAL USE ONLY – DO NOT DISTRIBUTE
FINAL 9

MOVEMENT: BILLINGS – HELENA/FORT HARRISON

LIMO:

CHASE:

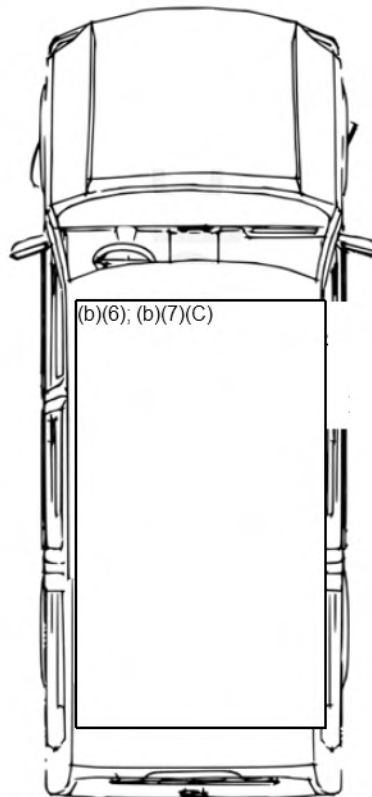
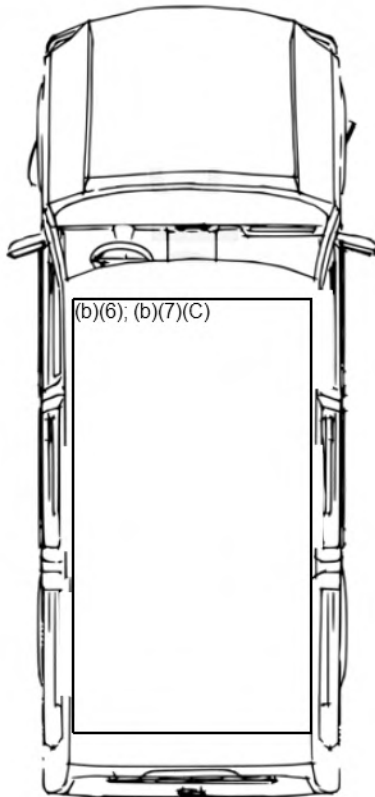

SEPTEMBER 28-29, 2020

FOR OFFICIAL USE ONLY – DO NOT DISTRIBUTE
FINAL 9

MOVEMENT: HELENA/FORT HARRISON – MISSOULA - KALISPELL

LIMO:

CHASE:

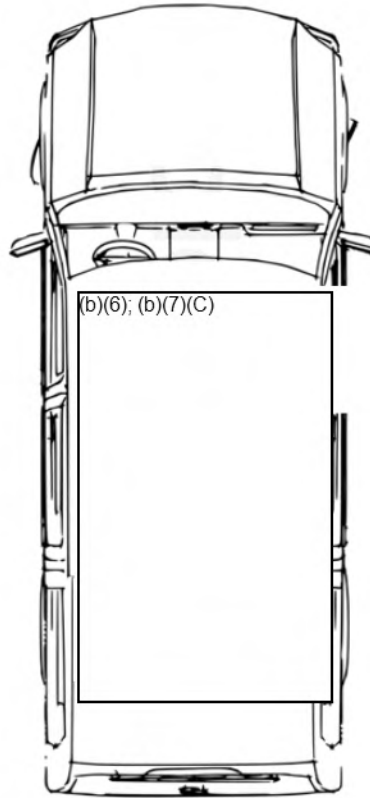
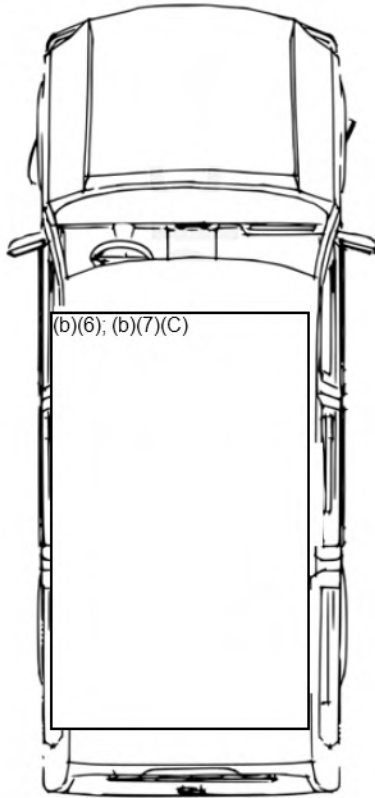

23-Sep Mini bar hotel, FL	\$8.13
23-Sep Wendy	\$7.70
24-Sep Versailles Rest	\$47.96
24-Sep MIA airport	\$11.96
24-Sep In N Out burger	\$7.72
24-Sep Mission Inn hotel dinner	\$61.29
25-Sep Raising Cane's	\$9.19
25-Sep Mini bar hotel Billings, MT	\$18.25
26-Sep Subway	\$8.58
26-Sep Hotel market, Helena, MT	\$24.00
27-Sep Winbag Saloon	\$37.00
28-Sep McD's	\$5.70
28-Sep Buffalo Wild Wing	\$28.78
28-Sep Hotel market, Kalispell, MT	\$3.50
29-Sep IHOP	\$18.88
Total	\$298.64



MIAMI AIRPORT MARRIOTT

GUEST FOLIO

771 WILKIE/ROBERT 95.00 09/24/20 12:00 26621
 ROOM NAME RATE DEPART TIME ACCT#
 CK VACO GROUP 09/23/20 11:15
 TYPE ARRIVE TIME
 223
 PASSPORT:
 ROOM CA
 CLERK ADDRESS PAYMENT MBV#: XXXX(b)(6)

DATE	REFERENCES	CHARGES	CREDITS	BALANCES DUE
09/23	PANTRY	8182 771	8.13	
09/23	RM REV	771, 1	95.00	
09/23	ST TAX	771, 1	6.65	
09/23	OCC TAX	771, 1	5.70	
09/24	CCARD-VS			115.48
				00

See our "Privacy & Cookie Statement" on Marriott.com



MIAMI AIRPORT MARRIOTT
1201 NW LEJEUNE RD
MIAMI : FL 33126

Treat yourself to the comfort of Marriott Hotels in your home. Visit ShopMarriott.com.

This statement is your only receipt. You have agreed to pay in cash or by approved personal check or to authorize us to charge your credit card for all amounts charged to you. The amounts shown in the credit column opposite any credit card entry in the reference column above will be charged to the credit card number set forth above. (The credit card company will bill in the usual manner.) If for any reason the credit card company does not make payment on this account, you will owe us such amount. If you are direct billed, in the event payment is not made within 25 days after check-out, you will owe us interest from the check-out date on any unpaid amount at the rate of 1.5% per month (ANNUAL RATE 18%), or the maximum allowed by law, plus the reasonable cost of collection, including attorney fees.

Signature X



RIVERSIDE MARRIOTT

GUEST FOLIO

1018 WILKIE/ROBERT 107.00 09/25/20 07:15 3208
 ROOM NAME RATE DEPART TIME ACCT#
 NKNC (b)(6)
 TYPE ARRIVE TIME
 111
 ROOM ADDRESS VSXXXXXXXXXX (b)(6) MBV#: XXX (b)(6)
 CLERK PAYMENT

DATE	REFERENCES	CHARGES	CREDITS	BALANCES DUE
09/24	GOVRNMT 1018, 1	107.00		
09/24	OCC.TAX 1018, 1	13.91	A	
09/24	CAL.FEE 1018, 1	.27	F	
09/25	CCARD-VS		121.18	
	PAYMENT RECEIVED BY: VISA XXXXXXXXXXXX (b)(6)			.00

DESCRIPTION		SUMMARY OF TAXES		TAXED AMOUNT	TAX
F	CAL TAX			.00	.27
	NET CHARGES	TAX		CREDITS	FOLIO
	120.91	.27		121.18	.00

See our "Privacy & Cookie Statement" on Marriott.com



RIVERSIDE MARRIOTT
 3400 MARKET STREET
 RIVERSIDE CA 92501
 951-784-8000 FAX 951-369-7127

Treat yourself to the comfort of Marriott Hotels in your home. Visit ShopMarriott.com.

This statement is your only receipt. You have agreed to pay in cash or by approved personal check or to authorize us to charge your credit card for all amounts charged to you. The amounts shown in the credit column opposite any credit card entry in the reference column above will be charged to the credit card number set forth above. (The credit card company will bill in the usual manner.) If for any reason the credit card company does not make payment on this account, you will owe us such amount. If you are direct billed, in the event payment is not made within 25 days after check-out, you will owe us interest from the check-out date on any unpaid amount at the rate of 1.5% per month (ANNUAL RATE 18%), or the maximum allowed by law, plus the reasonable cost of collection, including attorney fees.

Signature X



HILTON GARDEN INN-BILLINGS
 2465 GRANT ROAD
 BILLINGS, MT 59102
 United States of America
 TELEPHONE 406-655-8800 • FAX 406-655-8802
 Reservations
 www.hilton.com or 1 800 HILTONS

WILKIE, ROBERT

Room No: 431/K1RZ
 Arrival Date: 9/25/2020 5:47:00 PM
 Departure Date: 9/26/2020 10:41:00 AM
 Adult/Child: 2/0
 Cashier ID: (b)(6)
 Room Rate: 96.00
 AL:
 HH # (b)(6)
 VAT #
 Folio No/Che 416586 A

(b)(6)

UNITED STATES OF AMERICA

Confirmation Number: 3113877707

HILTON GARDEN INN-BILLINGS 10/7/2020 7:59:00 AM

DATE	DESCRIPTION	ID	REF NO	CHARGES	CREDIT	BALANCE
9/25/2020	PANTRY	(b)(6)	1609103	\$3.25		
9/25/2020	PANTRY ALLOWANCE		1609109		(\$3.25)	
9/25/2020	GUEST ROOM		1609216	\$96.00		
9/25/2020	RM-STATE TAX		1609216	\$7.68		
9/25/2020	RM-TBID TAX		1609216	\$2.00		
9/26/2020	PANTRY		1609314	\$2.25		
9/26/2020	*GREAT AMERICAN GRILL		1609316	\$16.00		
9/26/2020	VS (b)(6)		1609360		(\$123.93)	
BALANCE						\$0.00

THANK YOU FOR STAYING WITH US! YOU MAY RECEIVE A SURVEY FROM US AFTER YOU CHECK OUT. IF YOU ARE UNABLE TO SCORE US A 10 ON EVERY ASPECT OF YOUR STAY PLEASE STOP BY THE FRONT DESK AND ASK TO SPEAK TO THE MANAGER ON DUTY. WE WOULD LOVE YOUR FEEDBACK!



22 N Last Chance Gulch • Helena, MT 59601
 406-443-2200 • 406-442-4030
 For reservations across the nation
 www.doubletree.com or 1-800-222-TREE

Name & Address

WILKIE, ROBERT

(b)(6)

UNITED STATES OF AMERICA

Room 307/NKR
 Arrival Date 9/26/2020 1:01:00 PM
 Departure Date 9/28/2020

Adult/Child 1/0
 Room Rate 103.00

Rate Plan: GVT
 HH # (b)(6)
 AL:
 Car:

Confirmation Number: 97841596

9/28/2020



DATE	REFERENCE	DESCRIPTION	AMOUNT
9/26/2020	179350	MADE MARKET	\$12.00
9/26/2020	179385	GUEST ROOM	\$103.00
9/26/2020	179385	RM OCCUPANCY TAX	\$8.24
9/26/2020	179385	CITY TOURISM FEE	\$2.00
9/27/2020	178527	MADE MARKET	\$12.00
9/27/2020	179550	GUEST ROOM	\$103.00
9/27/2020	179550	RM OCCUPANCY TAX	\$8.24
9/27/2020	179550	CITY TOURISM FEE	\$2.00
9/28/2020	179619	VS (b)(6)	(\$250.48)
		BALANCE	\$0.00

Hilton Honors (R) stays are posted within 72 hours of checkout. To check your earnings or book your next stay at more than 5,700 hotels and resorts in 113 countries, please visit Honors.com



ACCOUNT NO.
 VS (b)(6)

CARD MEMBER NAME
 WILKIE, ROBERT

ESTABLISHMENT NO. & LOCATION ESTABLISHMENT AGREES TO TRANSFER TO CARD HOLDER FOR PAYMENT

CARD MEMBER'S SIGNATURE
 X

DATE OF CHARGE 9/28/2020 FOLIO NO./CHECK NO. 69622 A

AUTHORIZATION 073913 INITIAL

PURCHASES & SERVICES

TAXES

TIPS & MISC.

TOTAL AMOUNT -260.48

PAYMENT DUE UPON RECEIPT



MERCHANDISE AND/OR SERVICES PURCHASED ON THIS CARD SHALL NOT BE RESOLD OR RETURNED FOR A CASH REFUND.

HOMewood SUITES BY HILTON®



195 Hutton Ranch Road • Kalispell, MT 59901
 Phone (406) 755-8080 • Fax (406) 755-8086
 Reservations
 www.homewoodsuites.com or 1-800-CALL-HOME®

Name & Address

WILKIE, ROBERT

(b)(6)

UNITED STATES OF AMERICA

Suite 408/NKS
 Arrival Date 9/28/2020 4:29:00 PM
 Departure Date 9/29/2020 7:50:00 AM

Adult/Child 2/0
 Room Rate 96.00

Rate Plan: GVT
 HH # (b)(6)
 AL:
 Car:

Folio

Confirmation Number: 96269276

9/29/2020



DATE	REFERENCE	DESCRIPTION	AMOUNT
9/28/2020	477864	2x waters	\$3.50
9/28/2020	477946	GUEST ROOM EXEMPT	\$96.00
9/29/2020	477998	VS (b)(6)	(\$99.50)
		BALANCE	\$0.00

Hilton Honors(R) stays are posted within 72 hours of checkout. To check your earnings or book your next stay at more than 5,700 hotels and resorts in 113 countries, please visit Honors.com

Introducing Suite Selection. Check in online at homewoodsuites.com and choose the floor, the location and the suite you'll call home. Check out a demonstration at suiteselectiondemo.com.



ACCOUNT NO.
VS (b)(6)

CARD MEMBER NAME
WILKIE, ROBERT

ESTABLISHMENT NO. & LOCATION ESTABLISHMENT ADDRESS TO TRANSMIT TO CARDHOLDER FOR PAYMENT

DATE OF CHARGE 9/29/2020 FOLIO NO./CHECK NO. 151021 A

AUTHORIZATION 075267 INITIAL

PURCHASES & SERVICES

TAXES

TIPS & MISC

TOTAL AMOUNT -99.50

RESTAURANTS AND/OR SERVICES PURCHASED ON THIS CARD SHALL NOT BE REFUND OR RETURNED FOR A CASH REFUND.

PAYMENT DUE UPON RECEIPT

Traveler

Passenger Name:

WILKIE, ROBERT@

e-Ticket Number:

0017613729996-997

Reservation Number:

3X34WF

Issue Date:

September 19, 2020

Invoice Number:

00637482

Total Charges to Date:

USD 3012.24

Agency Details



Agency Phone:

877-813-5900

Fare Information

Form Of Payment:

VI XXXX XXXX XXXX 0215

Fare:

USD (b)(4)

Taxes and Carrier-imposed fees:

USD

USD

Total Airfare:

USD

Service Fee: (MCO Number : 8900808227130)

USD

Total Invoice:

USD 1143.80

Trip Information

Flight - American Airlines (AA) - 391 - September 23, 2020

Confirmation Number:

USUGRC

Status:

Confirmed

Depart:

Washington-National (DCA)

DC

6:58 AM

Arrive:

Miami International (MIA)

FL

9:34 AM

Class Of Service:

Economy

Flight - American Airlines (AA) - 1228 - September 24, 2020

Confirmation Number:

USUGRC

Status:

Confirmed

Depart:	Arrive:	Class Of Service:
Miami International (MIA)	Los Angeles (LAX)	Economy
FL	CA	
8:35 AM	11:03 AM	

Flight - American Airlines (AA) - 2945 - September 25, 2020

Confirmation Number:	Status:
USUGRC	Confirmed

Depart:	Arrive:	Class Of Service:
Ontario (ONT)	Dallas/FortWorth (DFW)	Economy
CA	TX	
12:40 PM	5:37 PM	

Flight - American Airlines (AA) - 4247 - September 25, 2020

Status:
Confirmed

Depart:	Arrive:	Class Of Service:
Dallas/FortWorth (DFW)	Billings (BIL)	Economy
TX	MT	
7:00 PM	8:52 PM	

Flight - American Airlines (AA) - 2922 - September 29, 2020

Confirmation Number:	Status:
USUGRC	Confirmed

Depart:	Arrive:	Class Of Service:
Kalispell/Glacier National Pk (FCA)	Dallas/FortWorth (DFW)	Economy
MT	TX	
12:30 PM	4:55 PM	

Flight - American Airlines (AA) - 2752 - September 29, 2020

Status:
Confirmed

Depart:	Arrive:	Class Of Service:
----------------	----------------	--------------------------

Dallas/FortWorth (DFW)	Washington-National (DCA)	Economy
TX	DC	
6:50 PM	10:50 PM	

Misc - July 13, 2021

Location Info:

Phone:

Other Info:

Number of Persons: 1

Remark: THIS DATE FOR

ACCOUNTING PURPOSES ONLY

Agent Comments

DUE TO RECENT CHANGES IN THE GOV CITY PAIR PROGRAM
 YOUR AIR RESERVATIONS ARE SUBJECT TO CANCELLATION
 BY THE AIRLINES IF NOT TICKETED AT LEAST 48 HOURS
 PRIOR TO SCHEDULED DEPARTURE. PLEASE ENSURE ALL
 NECESSARY APPROVALS ARE PROCESSED IN ACCORDANCE
 WITH YOUR AGENCY'S BUSINESS RULE BUT NO LESS THAN 3
 BUSINESS DAYS PRIOR TO DEPARTURE. THIS 48 HOUR
 CANCELLATION RULE DOES NOT APPLY TO YOUR
 INTERNATIONAL RESERVATIONS UNLESS YOUR TRIP HAS
 DOMESTIC CONNECTIONS ON MORE THAN ONE AIRLINE OR
 THESE RESERVATIONS WILL REQUIRE SEPARATE TICKETS.

101005928
 ZPIZAMERICAN AIR TICKET WAS CHARGED TO VI XXXXXXXXXXXX0215
 ZPIZAMERICAN AIR ELECTRONIC TICKET NUMBER IS 0017613729875
 ZPIZINVOICE NUMBER IS 77 I00
 ZPIZSERVICE FEE***** (b)(4)
 ZPIZTICKETED FARE***** (b)(4)
 ZPIZTOTAL CHARGE*****\$1868.44
 CB/CGEBILLING/ATRS/2020-09-16T14.35.00Z

101005928
 101005928
 ZPIZAMERICAN AIR TICKET WAS CHARGED TO VI XXXXXXXXXXXX0215
 ZPIZAMERICAN AIR ELECTRONIC TICKET NUMBER IS 0017613729996
 ZPIZINVOICE NUMBER IS 97 I00
 ZPIZSERVICE FEE***** (b)(4)
 ZPIZTICKETED FARE***** (b)(4)
 ZPIZTOTAL CHARGE*****\$1143.80
 CB/CGEBILLING/ATRS/2020-09-19T18.49.00Z

Expense Receipt

101005928

101005928

ZPIZAMERICAN AIR TICKET WAS CHARGED TO VI XXXXXXXXXXXX0215

ZPIZAMERICAN AIR ELECTRONIC TICKET NUMBER IS 0017613729996

ZPIZINVOICE NUMBER IS 97 I00

ZPIZSERVICE FEE***** (b)(4)

ZPIZTICKETED FARE*****

ZPIZTOTAL CHARGE*****\$1143.80

CB/CGEBILLING/ATRS/2020-09-19T21.05.00Z

Trip Information

Flight - American Airlines (AA) - 391 - September 23, 2020

Confirmation Number:	Status:
USUGRC	Confirmed

Traveler

Passenger Name: WILKIE, ROBERT@	e-Ticket Number: 0017613729875-877	Reservation Number: 3X34WF	Issue Date: September 16, 2020
Invoice Number: 00637371	Total Charges to Date: USD 3012.24		

Agency Details

Agency Phone:
877-813-5900

Fare Information**Form Of Payment:**

VI XXXX XXXX XXXX 0215

Fare:	USD (b)(4)
Taxes and Carrier-imposed fees:	USD
	USD
Total Airfare:	USD
Service Fee: (MCO Number : 8900808212619)	USD
Total Invoice:	USD 1868.44

Trip Information**Flight - American Airlines (AA) - 391 - September 23, 2020**

Confirmation Number: USUGRC	Status: Confirmed
---------------------------------------	-----------------------------

Depart: Washington-National (DCA) DC 6:58 AM	Arrive: Miami International (MIA) FL 9:34 AM	Class Of Service: Economy
--------------------------------------------------------------	--------------------------------------------------------------	-------------------------------------

Flight - American Airlines (AA) - 1228 - September 24, 2020

Confirmation Number: USUGRC	Status: Confirmed
---------------------------------------	-----------------------------

Depart:	Arrive:	Class Of Service:
Miami International (MIA)	Los Angeles (LAX)	Economy
FL	CA	
8:35 AM	11:03 AM	

Flight - American Airlines (AA) - 2945 - September 25, 2020

Confirmation Number:	Status:
USUGRC	Confirmed

Depart:	Arrive:	Class Of Service:
Ontario (ONT)	Dallas/FortWorth (DFW)	Economy
CA	TX	
12:40 PM	5:37 PM	

Flight - American Airlines (AA) - 4247 - September 25, 2020

Status:
Confirmed

Depart:	Arrive:	Class Of Service:
Dallas/FortWorth (DFW)	Billings (BIL)	Economy
TX	MT	
7:00 PM	8:52 PM	

Flight - American Airlines (AA) - 2922 - September 29, 2020

Confirmation Number:	Status:
USUGRC	Confirmed

Depart:	Arrive:	Class Of Service:
Kalispell/Glacier National Pk (FCA)	Dallas/FortWorth (DFW)	Economy
MT	TX	
12:30 PM	4:55 PM	

Flight - American Airlines (AA) - 2752 - September 29, 2020

Status:
Confirmed

Depart:	Arrive:	Class Of Service:
----------------	----------------	--------------------------

Dallas/FortWorth (DFW)	Washington-National (DCA)	Economy
TX	DC	
6:50 PM	10:50 PM	

Misc - July 13, 2021

Location Info:

Phone:

Other Info:

Number of Persons: 1

Remark: THIS DATE FOR

ACCOUNTING PURPOSES ONLY

Agent Comments

DUE TO RECENT CHANGES IN THE GOV CITY PAIR PROGRAM
 YOUR AIR RESERVATIONS ARE SUBJECT TO CANCELLATION
 BY THE AIRLINES IF NOT TICKETED AT LEAST 48 HOURS
 PRIOR TO SCHEDULED DEPARTURE. PLEASE ENSURE ALL
 NECESSARY APPROVALS ARE PROCESSED IN ACCORDANCE
 WITH YOUR AGENCY'S BUSINESS RULE BUT NO LESS THAN 3
 BUSINESS DAYS PRIOR TO DEPARTURE. THIS 48 HOUR
 CANCELLATION RULE DOES NOT APPLY TO YOUR
 INTERNATIONAL RESERVATIONS UNLESS YOUR TRIP HAS
 DOMESTIC CONNECTIONS ON MORE THAN ONE AIRLINE OR
 THESE RESERVATIONS WILL REQUIRE SEPARATE TICKETS.

101005928
 ZPIZAMERICAN AIR TICKET WAS CHARGED TO VI XXXXXXXXXXXX0215
 ZPIZAMERICAN AIR ELECTRONIC TICKET NUMBER IS 0017613729875
 ZPIZINVOICE NUMBER IS 77 I00
 ZPIZSERVICE FEE***** (b)(4)
 ZPIZTICKETED FARE***** (b)(4)
 ZPIZTOTAL CHARGE*****\$1868.44

CB/CGEBILLING/ATRS/2020-09-16T14.35.00Z

101005928

101005928

ZPIZAMERICAN AIR TICKET WAS CHARGED TO VI XXXXXXXXXXXX0215
 ZPIZAMERICAN AIR ELECTRONIC TICKET NUMBER IS 0017613729996
 ZPIZINVOICE NUMBER IS 97 I00
 ZPIZSERVICE FEE***** (b)(4)
 ZPIZTICKETED FARE***** (b)(4)
 ZPIZTOTAL CHARGE*****\$1143.80

CB/CGEBILLING/ATRS/2020-09-19T18.49.00Z

Expense Receipt

101005928

101005928

ZPIZAMERICAN AIR TICKET WAS CHARGED TO VI XXXXXXXXXXXX0215

ZPIZAMERICAN AIR ELECTRONIC TICKET NUMBER IS 0017613729996

ZPIZINVOICE NUMBER IS 97 I00

ZPIZSERVICE FEE***** (b)(4)

ZPIZTICKETED FARE***** (b)(4)

ZPIZTOTAL CHARGE*****\$1143.80

CB/CGEBILLING/ATRS/2020-09-19T21.05.00Z



Duluth Government
 2860 Peachtree Ind. Blvd., Suite 1000
 Duluth, GA 30097
 Phone: (877) 813-5900

Monday, 21SEP 2020 2:12 PM EDT

Passengers: ROBERT WILKIE (101005928/ 101005928)

Agency Reference Number: 3X34WF

Click here to view your current itinerary or ETicket receipt on-line: viewtrip.travelport.com

Fare Quote total: 1082.23 USD -- not guaranteed until ticketed

Do you have your REAL ID to travel? Click HERE for more information.

Enjoy parking discounts from Duluth Travel Inc HERE

AIR	Wednesday, 23SEP 2020		
American Airlines From: Washington Reagan Natl DC, USA To: Miami FL, USA Stops: Nonstop Seats: 11D Equipment: Boeing 737-800 Jet DEPARTS DCA TERMINAL C Frequent Flyer Number: (b)(6) Fare Basis: GCADCA American Airlines Confirmation number is USUGRC		Flight Number: 0391 Depart: 6:58 AM Arrive: 9:34 AM Duration: 2 hour(s) 36 minute(s) Status: CONFIRMED MEAL: REFRSHMNT/COMP	Class: G- Coach/Economy Miles: 923 / 1477 KM

HOTEL	Wednesday, 23SEP 2020		
Miami Airport Marriott (MARRIOTT) 1201 Nw Le Jeune RD Building A Miami FL US 33126 Number of Rooms: 1 Phone: 13056495000 Rate: USD 95.00 Check Out: Thursday, 24SEP 2020 Room Type: GOVA00 Guaranteed to: VI***** (b)(6) Hotel cancellation policy: CANCEL PERMITTED UP TO 01 DAYS BEFORE ARRIVAL. 107.35 CANCEL FEE PER ROOM.		Confirmation Number: 80445750 Fax: 13056423369 Room GUARANTEED TO VISA Reserved For: WILKIE ROBERT	

AIR	Thursday, 24SEP 2020		
American Airlines From: Miami FL, USA To: Los Angeles CA, USA Stops: Nonstop Seats: 14C		Flight Number: 1228 Depart: 8:35 AM Arrive: 11:03 AM Duration: 5 hour(s) 28 minute(s) Status: CONFIRMED	Class: G- Coach/Economy Miles: 2339 / 3742 KM

Equipment: Airbus A321 Jet

MEAL: REFRSHMNT/COMP

Frequent Flyer Number: (b)(6)

Fare Basis: GCA

American Airlines Confirmation number is USUGRC

HOTEL Thursday, 24SEP 2020



Marriott Riverside Conv Center (MARRIOTT)

3400 Market Street Riverside CA US 92501

Number of Rooms: 1

Confirmation Number: 77047976

Phone: 19517848000

Fax: 19513697127

Rate: USD 107.00

Room GUARANTEED TO VISA

Check Out: Friday, 25SEP 2020

Reserved For: WILKIE ROBERT

Room Type: GOVA00

Guaranteed to: VI***** (b)(6)

Hotel cancellation policy: CANCEL PERMITTED UP TO 01 DAYS BEFORE ARRIVAL. 121.18 CANCEL FEE PER ROOM.

AIR Friday, 25SEP 2020



American Airlines

Flight Number: 2945

Class: G- Coach/Economy

From: Ontario CA, USA

Depart: 12:40 PM

To: Dallas/Ft Worth TX, USA

Arrive: 5:37 PM

Stops: Nonstop

Duration: 2 hour(s) 57 minute(s)

Seats: 15A

Status: CONFIRMED

Miles: 1193 / 1909 KM

Equipment: Airbus A321 Jet

MEAL: REFRSHMNT/COMP

DEPARTS ONT TERMINAL 4

Frequent Flyer Number: (b)(6)

AISLE/WINDOW NOT AVAILABLE. MIDDLE CONFIRMED.CHECK AT CKIN

Fare Basis: GCA

American Airlines Confirmation number is USUGRC

AIR Friday, 25SEP 2020



American Airlines

Flight Number: 4247

Class: G- Coach/Economy

OPERATED BY ENVOY AIR AS AMERICAN EAGLE

From: Dallas/Ft Worth TX, USA

Depart: 7:00 PM

To: Billings MT, USA

Arrive: 8:52 PM

Stops: Nonstop

Duration: 2 hour(s) 52 minute(s)

Seats: 13D

Status: CONFIRMED

Miles: 1085 / 1736 KM

Equipment: EMBRAER EMB 175

Frequent Flyer Number: (b)(6)

Fare Basis: GCA

American Airlines Confirmation number is USUGRC

HOTEL Friday, 25SEP 2020



Hilton Garden INN Billings (HILTON GARDEN INN)

2465 Grant Road Billings MT 59102

Number of Rooms: 1

Confirmation Number: 3115802335

Phone: 1-406-655-8800

Fax: 1-406-655-8802

Rate: USD 96.00

Room GUARANTEED TO VISA

Check Out: Saturday, 26SEP 2020

Reserved For: WILKIE ROBERT

Room Type: A01A0A

Guaranteed to: VI***** (b)(6)

Hotel cancellation policy: CXL 1 DAY PRIOR TO ARRIVAL

Approximate total: TTL-104.72 USD

HOTEL Saturday, 26SEP 2020



Doubletree By Hilton Helena (DOUBLETREE)

22 N Last Chance Gulch Helena MT 59601

Number of Rooms: 1

Phone: -406-447-6666

Rate: USD 103.00

Check Out: Monday, 28SEP 2020

Room Type: A00A08

Confirmation Number: 97841596

Fax: 0-406-442-4030

Room GUARANTEED TO VISA

Reserved For: WILKIE ROBERT

Guaranteed to: VI*****

Hotel cancellation policy: 48 HR CANCELLATION REQUIRED

Approximate total: TTL-226.48 USD

HOTEL Monday, 28SEP 2020



Homewood Suites By Hilton Kali (HOMEWOOD SUITE)

195 Hutton Ranch Road Kalispell MT 59901

Number of Rooms: 1

Phone: 1-406-755-8080

Rate: USD 96.00

Check Out: Tuesday, 29SEP 2020

Room Type: GOV

Confirmation Number: 96269276

Fax: 1-406-755-8086

Hotel cancellation policy: 24HRS PRIOR OF ARRIVAL

AIR Tuesday, 29SEP 2020



American Airlines

From: Kalispell MT, USA

To: Dallas/Ft Worth TX, USA

Stops: Nonstop

Seats: 11C

Equipment: Boeing 737-800 Jet

Frequent Flyer Number

Fare Basis: SDGDCA

American Airlines Confirmation number is USUGRC

Flight Number: 2922

Depart: 12:30 PM

Arrive: 4:55 PM

Duration: 3 hour(s) 25 minute(s)

Status: CONFIRMED

MEAL: REFRSHMNT/COMP

Class: S- Coach/Economy

Miles: 1395 / 2232 KM

AIR Tuesday, 29SEP 2020



American Airlines

From: Dallas/Ft Worth TX, USA

To: Washington Reagan Natl DC, USA

Stops: Nonstop

Seats: 12C

Equipment: Boeing 737-800 Jet

ARRIVES DCA TERMINAL C

Frequent Flyer Number

Fare Basis: SDGDCA

American Airlines Confirmation number is USUGRC

Flight Number: 2752

Depart: 6:50 PM

Arrive: 10:50 PM

Duration: 3 hour(s) 0 minute(s)

Status: CONFIRMED

MEAL: REFRSHMNT/COMP

Class: S- Coach/Economy

Miles: 1177 / 1883 KM

[Click here to review Baggage policies and guidelines:](#)

American

Check operating carrier website for any policies that may vary.

ZPIZAMERICAN AIR TICKET WAS CHARGED TO VI XXXXXXXXXXXXX0215
ZPIZAMERICAN AIR ELECTRONIC TICKET NUMBER IS 0017613729875
ZPIZINVOICE NUMBER IS 77 I00

ZPIZSERVICE FEE***** (b)(4) *****
ZPIZTICKETED FARE***** (b)(4) *****
ZPIZTOTAL CHARGE*****\$1868.44 *****

CB/CGEBILLING/ATRS/2020-09-16T14.35.00Z
ZPIZAMERICAN AIR TICKET WAS CHARGED TO VI XXXXXXXXXXXXX0215
ZPIZAMERICAN AIR ELECTRONIC TICKET NUMBER IS 0017613729996
ZPIZINVOICE NUMBER IS 97 I00

ZPIZSERVICE FEE***** (b)(4) *****
ZPIZTICKETED FARE*****\$ (b)(4) *****
ZPIZTOTAL CHARGE*****\$1143.80 *****

CB/CGEBILLING/ATRS/2020-09-19T18.49.00Z
ZPIZAMERICAN AIR TICKET WAS CHARGED TO VI XXXXXXXXXXXXX0215
ZPIZAMERICAN AIR ELECTRONIC TICKET NUMBER IS 0017613729996
ZPIZINVOICE NUMBER IS 97 I00

ZPIZSERVICE FEE***** (b)(4) *****
ZPIZTICKETED FARE*****\$ (b)(4) *****
ZPIZTOTAL CHARGE*****\$1143.80 *****

CB/CGEBILLING/ATRS/2020-09-19T21.05.00Z

DUE TO RECENT CHANGES IN THE GOV CITY PAIR PROGRAM
YOUR AIR RESERVATIONS ARE SUBJECT TO CANCELLATION
BY THE AIRLINES IF NOT TICKETED AT LEAST 48 HOURS
PRIOR TO SCHEDULED DEPARTURE. PLEASE ENSURE ALL
NECESSARY APPROVALS ARE PROCESSED IN ACCORDANCE
WITH YOUR AGENCYS BUSINESS RULE BUT NO LESS THAN 3
BUSINESS DAYS PRIOR TO DEPARTURE. THIS 48 HOUR
CANCELLATION RULE DOES NOT APPLY TO YOUR
INTERNATIONAL RESERVATIONS UNLESS YOUR TRIP HAS
DOMESTIC CONNECTIONS ON MORE THAN ONE AIRLINE OR
THESE RESERVATIONS WILL REQUIRE SEPARATE TICKETS.

- 1010O5928
- 1010O5928
- 1010O5928
- 1010O5928
- 1010O5928

**For travel agent assistance and emergencies, please call 1-877-813-5900.
Your TMC Code is "11T" Duluth Travel

New TSA guidelines
<https://www.tsa.gov/news/releases/2019/04/04/tsa-reminds-travelers-real-id-identification-requirements>
