

CONTINUOUS RENAL REPLACEMENT THERAPY (CRRT)

Dr. Manish Chaturvedi
Nephrologist,
Dr. S. N. Medical College,
Jodhpur

It is a mode of renal replacement therapy for hemodynamically unstable, fluid overloaded, catabolic septic patients and finds its application in management of acute renal failure especially in the critical care /intensive care unit setting. The popularity of 'slow continuous therapies' for the treatment of critically ill patients with renal failure is increasing. The techniques most commonly used are slow continuous hemodialysis and hemodiafiltration. Slow continuous hemofiltration and slow continuous ultrafiltration also are commonly used.

ARF in the ICU setting is frequent especially secondary to multiple organ dysfunction syndrome; post surgical setting i.e after abdominal surgery; post interventional studies eg. PTCA, PTR studies in already susceptible individuals. These patients having various co-morbid conditions are on mechanical ventilation and various life supporting modalities which do not merit the dialysis procedure to be carried out in the routine dialysis set up.

Being catabolic, they require continuous clearance of waste produced due to ongoing illnesses and an adequate potential for infusion of nutritional and inotropic agents for sustenance of vital parameters which is continuously desired in the management. CRRT has tried to meet these challenges in the ICU settings since its inception and has saved many lives across the globe including critically ill paediatric or geriatric population with renal failure as a co-existent co-morbid illness.

The outcome of therapy depends on clearance of waste products achieved with restoration of blood biochemistry; maintenance of fluid, electrolyte and acid base balance; ability to maintain hemodynamic stability during the procedure with minimum side effects during the procedure.

GOALS OF CRRT THERAPY

The aggressive management in initial hours to counter the derangements in critically ill patients is the cornerstone in the therapy. CRRT initiated for ARF in critically ill patients should serve as a renal 'replacement' therapy mimicking as artificial kidney support. It should enhance recovery of the native kidneys with prevention of hyperkalemia, hyper/hyponatremia, acidosis/alkalosis and rapid correction of pulmonary/peripheral edema by gradual and consistent removal of surplus fluid retained in the body. It should also diffuse the various ongoing smoldering proinflammatory mediators especially in multiple organ dysfunction syndromes.

HISTORY

It was originally promoted by Kramer and associates for treatment of hypotensive patients. Its efficacy was later proven by Peganini in 1984, who used

CRRT in hemodynamically unstable patients rendering improved survival by this modality.

INDICATION FOR INIATION OF CRRT:

Presence of marked azotemia, fluid overload, or both; maintaining electrolyte, acid-base, and solute homeostasis. Persistent oliguria, hyperkalemia refractory pulmonary edema or fluid overload, pericarditis, hypothermia, hyperthermia, poisonings with a dialyzable toxin and serial rise in blood urea and serum creatinine.

PROCESS

a) Hemodialysis

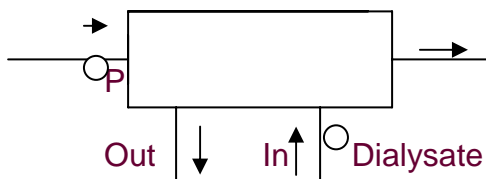

Blood flow: 250-300ml/min

Dialysate flow: 500ml/min

Membrane: Cuprophan; Hemophan

Mechanism: diffusion

Replacement solution: not required

This process effectively removes small molecular weight solutes.

b) Hemofiltration:

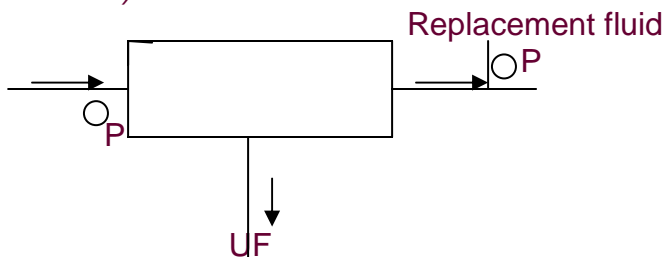

Blood flow: 500ml/min

Dialysate flow: nil

Membrane: highly permeable; AN-69; Polyamide; Polysulphone

Mechanism: convection

Replacement fluid: calcium & lactate containing fluid

Over 3-4 hours 30 litres of fluid may be taken out.

c) Hemodiafiltration

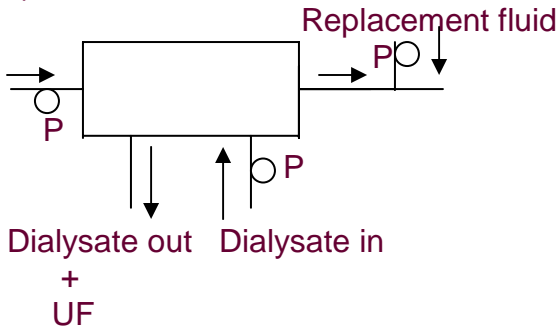

Membrane: Polysulphone; AN-69
Mechanism: diffusion+ convection
Replacement fluid: calcium+ bicarbonate

d) High flux dialysis

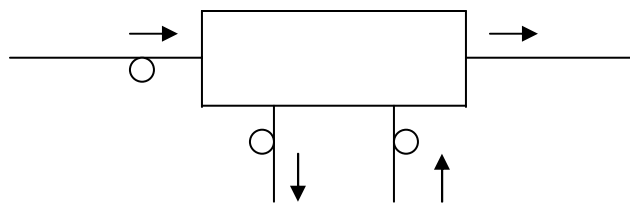

Membrane: Polysulphone, AN69
Mechanism: diffusion + convection
Pressure in dialysate is increased in the setting of both convection and diffusion. Dialysate back filters into the distal part of dialyzer which tends to correct the fluid balance. Thus, use of sterile/ultrapure dialysate is recommended.

ACCESS

a) Arteriovenous access

Femoral artery → Femoral vein

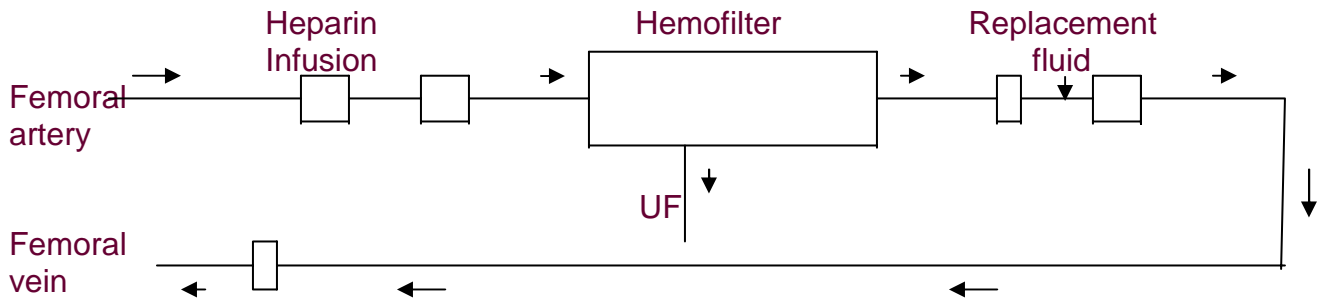

Advantage:

No pump is required. The mean arterial pressure drives the blood into the filter /dialyzer.

Risks

1. Atheroembolism
2. Ischemia of the limb
3. Hematoma formation
4. Hemorrhage
5. Arterial wall injury
6. Spasm of the artery cannulated

~The patient has to remain in bed till the catheter is in situ.

The use of CAVH, even though does not require a pump, is associated with increased risk of bleeding from puncture site in artery and inadvertent disconnection during the procedure are potential risks encountered. The clearance rate of urea and other wastes cannot be enhanced beyond a limit on account of fluctuations in blood pressure during the flow of blood through the dialyzer or hemofilter. Low blood pressure can even decrease the blood perfused in the circuit with recurrent clotting problems in the dialyzer/hemofilter.

b) Venovenous access

A double lumen cannula is inserted into a large vein. Internal jugular vein is preferred over femoral vein and femoral vein is opted over subclavian vein. This access requires a roller pump as the driving force of mean arterial pressure is not present here.

Advantages:

This method gives rapid and constant blood flow rate; improved dialyzer performance and decreased line and dialyzer clotting.

CVVH with its ease of cannulating a central vein and use of a pump in the circuit is used more frequently as a CRRT procedure in the ICU setting with greater removal of urea, metabolic wastes and surplus fluid by adjusting the pump speed.

Disadvantages:

Air embolism; hemorrhage due to inadvertent disconnection; longer blood lines used in extra corporeal circuit which are more liable to clot; central vein thrombosis and stenosis risk; and addition of gadgets in the circuit like, air bubble trap, alarms etc.

NOMENCLATURE:

CONTINUOUS + ACCESS + METHOD
 Continuous ArterioVenous HemoDiafiltration ----- CAVHD

	scuf	continuous hemofiltration	continuous hemodialysis	continuous hemodiafiltration
Arteriovenous(AV) Or Venovenous(VV)	AV or VV	AV/VV	AV/VV	AV/VV
Blood flow(ml/min)	50-100	50-200	50-200	50-200
Dialysate flow(ml/min)	-	-	10-20	10-20
Clearance(L/24hr)	-	12-36	14-36	20-40
Ultrafiltration rate (ml/min)	2-5	8-25	2-4	8-12
Blood filter	Highly permeable filter	Highly permeable filter	Low permeability dialyzer with countercurrent flow through dialyzer compartment	High permeability dialyzer with countercurrent flow through dialyzer compartment
Ultrafiltrate	Corresponds exactly to patient's weight loss	Replaced in part or completely to achieve purification and volume control	Corresponds to weight loss; solute clearance by diffusion	In excess of patient's weight loss; solute clearance by both diffusion and convection.
Replacement fluid	none	yes	none	Yes; to achieve fluid balance
Efficiency	Used only for fluid control in overhydrated states	Clearance for all solutes equals ultrafiltration	Limited to small molecules	Extends from small to large molecules

Continuous high flux dialysis

Blood flow 50-200 ml/min

Dialysate flow 50-200 ml/min

Ultrafiltration rate 2-8 ml/min

Blood is driven through a highly permeable dialyzer and a countercurrent flow of dialysis solution is delivered in single pass or re-circulation mode. The ultrafiltration production is controlled by a couple of pumps and regulated by gravimetric control. Replacement fluid is not required since fine regulation of filtration and back filtration achieves fluid balance.

In this mode convection and diffusion are combined and optimized.

Continuous Plasma Filtration-adsorption

In this technique blood is driven through a highly permeable plasma filter. The plasma filtrate is then circulated in a bed of adsorptive substance (carbon/resins) in order to obtain selective removal of molecules by adsorption.

Fluid balance is maintained and no replacement fluid is needed. It can be coupled with continuous hemofiltration /hemodialysis. It is indicated for treatment/removal of mediators of sepsis pro-inflammatory agents.

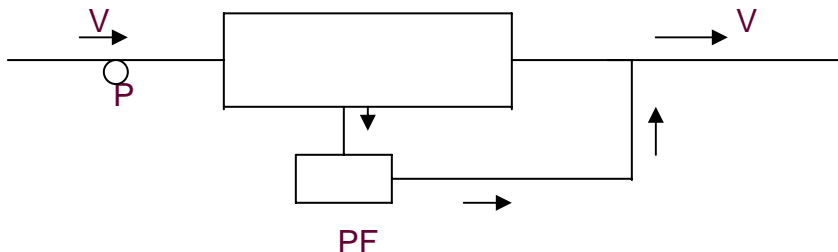

Mechanism of fluid and solute removal

Diffusion is the process where movement of solutes occurs across a semi-permeable membrane depending on the concentration gradient of the solute, its molecular weight, velocity size.

Ultrafiltration involves movement of water by hydrostatic or an osmotic force across a semi-permeable membrane with concomitant solute "drag" even if the concentration of the solutes is close to their original concentration. If hydrostatic pressure is the determinant, then the transmembrane pressure (calculated as the pressure difference across the membrane) is significant. Increased ultrafiltration can be achieved by increasing the transmembrane pressure. In CRRT, the transmembrane pressure can be increased by lowering the dialysate drain bag/applying suction to the dialysate drain line (which increases the negative pressure in the dialysate compartment.) or by increasing positive pressure in the blood compartment by increasing blood flow rate by adjusting prefilter blood pump or by increasing the venous resistance by decreasing venous return.

Predilution of the blood prior to its entry in the dialyzer with replacement fluid can lead to decreased requirement of anticoagulation and also by maintaining the concentration gradient.

Dialysate characteristics:

Usually the dialysate does not come in contact with blood except during high flux dialysis where dialysate can backleak into the blood compartment leading to permeation of bacterial endotoxins.

Glucose rich solutions can lead to hyperglycemia. Lactate is commonly used as buffer. In conditions where inadequate lactate metabolism takes place (eg. in liver failure) the bicarbonate based dialysate is preferred.

A. Dialysate A solution-contains 4.5 litres of electrolyte solution with calcium, magnesium lactic acid which increases carbondioxide which prevents precipitation of calcium and magnesium.

B. Dialysate B solution contains 8.4% bicarbonate.

Replacement fluids contain normal saline with calcium chloride; normal saline with magnesium sulphate; half normal saline; half normal saline with sodium bicarbonate.

Anticoagulation

The major disadvantage of CRRT is the need for continuous anticoagulation leading to increased risk of bleeding, thrombocytopenia. Patients having impaired liver functions and having thrombocytopenia ($50,000/\text{mm}^3$) anticoagulation is not required.

Procedure

The filter is primed with 1-2 litres of heparinized saline @400-800 IU/hr with monitoring of Clotting time (1.5-2 times normal) or PTTK. Low molecular weight heparin can also be used with monitoring of anti Xa activity (0.3-0.6 times anti Xa activity)

Prostacyclin with low dose heparin; citrate; protamine can be used in patients with high risk of bleeding.

ADVANTAGES OF CRRT

1. CRRT by its lower rate of fluid removal can lead to steady state fluid equilibrium in hemodynamically unstable, critically ill patients with associated co-morbid conditions eg. M.I, ARDS, septicemia, bleeding disorders.
2. It provides excellent control of azotemia, electrolytes and acid base balance. These patients are catabolic thus, removal of urea is mandatory to effectively control azotemia.
3. It is efficacious in removing fluid in special circumstances – post surgery pulmonary edema; ARDS etc.

4. CRRT can help in administration of parenteral nutrition and obligatory I.V medications like pressors & inotropes by creating an unlimited space by virtue of continuous ultrafiltration.
5. Hemofiltration modality is effective in lowering intracranial tension v/s routine intermittent hemodialysis which can sometimes raise intracranial tension.
6. Proinflammatory mediators of inflammation are also shown to have been removed by this modality eg.IL-1, IL-6, IL-8, TNF-a.

DISADVANTAGES

This mode of therapy requires regular monitoring of hemodynamic status and fluid balance (ultrafiltration rate, replacement fluid); regular infusion of dialysate; continuous anticoagulation; ongoing alarms and an expensive mode of therapy above all.

COMPLICATIONS

- A.Technical-1.vascular access malformation 2.Air embolism 3.circuit blood clotting and decreased blood flow 4.Fluid and electrolyte imbalance.
B.Clinical-1.Bleeding 2.Thrombosis 3.Infection/sepsis 4.Bioincompatibility of membranes 5.Hypothermia 6.Nutrient losses.

INDICATIONS OF CRRT

a. RENAL CAUSES

1. ARF with cardiovascular instability
2. ARF with septicemia
3. ARF with septicemia and ARDS.
4. ARF with cerebral edema

b. NONRENAL CAUSES

1. Systemic inflammatory response syndrome
2. Crush syndrome
3. Lactic acidosis
4. C.H.F

DIALYSIS MODALITIES FOR ACUTE RENAL FAILURE

Intermittent therapies

Hemodialysis
Hemodiafiltration
Ultrafiltration
Extended daily dialysis
Slow continuous dialysis

Continuous therapies

Peritoneal dialysis
Slow continuous ultrafiltration
Hemofiltration (CAVH, CVVH)
Hemodialysis (CAVHD, CVVHD)
Hemodiafiltration (CAVHDF, CVVHDF)

Acute renal failure in the ICU is a clinically diverse entity. Consequently, the indications for initiation of dialysis therapy are varied. Usually, the indications are solute control, volume control, or both. A variety of dialysis modalities are available; however, there is no consensus as to the optimal modality for any

particular group of patients. A careful understanding of the particular benefits, limitations and potential complications of each modality coupled with a thorough assessment of the individual patient's need formulate the basis for the dialysis modality selection. In certain circumstances, the more conventional intermittent therapies are sufficient, whereas in other settings, CRRT techniques are advantageous. The impact of modality selection on outcome remains an area of significant controversy. Future newer therapies aimed at more optimal and more specific blood purification may prove promising in the management of complex critically ill patients with ARF and other co-morbid conditions. Of note in this regard is the experimental technique by David Hume et al who have created a bioartificial kidney which incorporates a hemofilter (analogous to a glomerular unit) with tubular cell lines laid on hollow tubes of less immunogenic nature ; where the ultrafiltrate produced removes the excess of fluid, and circulation through the tubular cell lines causes resorption of essential nutrients (glucose, amino acids etc.) and various electrolytes like sodium, calcium may be achieved. It also serves the endocrinal function by synthesizing active form of vitamin D.

REFERANCES:

1. Bellomo R, Ronco C. Continuous renal replacement therapy in the intensive care unit. *Intensive Care Med* 1999;25:781-789.
2. Abdeen O, Mehta R.L. Dialysis modality in the intensive care unit. *Crit Care Clin* 2002;18:2;223-247.
3. Bellomo R, Ronco C. Indications and criteria for initiating renal replacement therapy in the intensive care unit. *Kidney Int* 1998, Vol.53, Suppl.66:S-106-109.
4. Burchardi H. History and development of continuous renal replacement techniques. *Kidney Int* 1998, Vol.53, Suppl.66:S120-124.
5. Manns M, Sigler M, Teehan BP. Continuous renal replacement therapy: an update. *Am J Kidney Dis* 1998,32:185-207.