

Stanford University

CENTRAL CAMPUS DESIGN GUIDELINES & COLOR/MATERIAL PALETTE



UNIVERSITY ARCHITECT/PLANNING OFFICE

2002

Contents

- I. INTRODUCTION 3
- II. BACKGROUND: STANFORD CAMPUS PLAN 7
- III. PARAMETERS 9
- IV. PLANNING GUIDELINES: 11
 - SITE AND LANDSCAPE CHARACTER 11
 - FACILITY SITING CRITERIA 14
 - CIRCULATION ELEMENTS 15
 - SITE & LANDSCAPE CHARACTER 17
 - ARCHITECTURAL CHARACTER 21
- IV. MATERIALS AND COLOR 26
 - SPECIFIC MATERIALS AND COLORS 27

I. Introduction

As Stanford University approached its centennial in 1991, much thought was given to both its history and its future. An actual physical assessment included the evaluation of its original (1888) master plan by Frederick Law Olmsted and Leland and Jane Stanford, and its prospective rejuvenation to reestablish a sense of unity and harmony that had been nearly lost during the previous decades of building development. The original plan was found to be as pragmatic 100 years later as the Stanfords hoped it would be. While the structure of the Olmsted-Stanford plan was still evident, succeeding generations of campus builders had imposed new fashions in architectural and landscape design. This is not to say that Stanford's 20th century campus design was undistinguished. The campus still displayed the vigor of its growth and attraction to new ideas in planning, landscape and architecture.

However, previous development eras ranged from the *Beaux Arts* eclecticism of the latter days of Jane Stanford and the extended period of San Francisco architects, Bakewell and Brown (and their involvement through World War II) to the later *modernism* of J. C. Warnecke and E. D. Stone, to the *post-modernism* of Kohn Pendersen Fox and Arthur Eriksen in the late 1980s. Each had left its distinctive, mostly unrelated, impression on the original order of the campus. Yet such was the power of the original, monumental plan—with its strong axial arrangement (emphasizing the symbiotic relationship of its landscape, natural setting, and architecture)—that this strength remained evident to both the casual user and the learned professional, despite its impacted form.

With these observations held in mind, the original tenets of connectivity, balance, order, growth, and reuse were carefully evaluated for relevance to education and research in the University's next century. The outcome of this endeavor was the confirmation that the founding physical planning principles of Stanford remained solid and relevant; therefore, the original master plan that so clearly represented these intentions could serve as the guide for future redevelopment and expansion. With adaptation, the plan could be the visible manifestation of Stanford's continuing commitments to reason and beauty, to order and complexity, to history and opportunity. These thoughts and evaluations were assembled in a report to the Stanford Board of Trustees in 1991 as *The Plan for the Second Century*, and were endorsed enthusiastically.



Campus Plan Diagram, 1888
(Frederick Law Olmsted)



Campus Plan Diagram, 2002
(William Johnson, FASLA)

As an important part of this planning treatise, a hierarchy of plan (order), landscape (setting), and architecture (facility), was re-established in keeping with the 1888 Olmsted-Stanford plan. In contrast to the environments of earlier American campuses—like Yale University with its village green, Harvard with its yard, and the University of Virginia with its central lawn (each of which was defined by its architectural surroundings)—Stanford’s campus environment is set by the order of the plan and the landscape surroundings (both natural and man-made) with its architecture set within this context.

Also in 1991, a set of “fundamental elements” was recognized. These are the pedestrian axes, the loop road, the landscape perimeters, and the Main Quad-rangle and its flanking linear quad organization. In addition, a hierarchy of planning (from broad land use plans to individual site plans) was established, and the need for design guidelines in all major regions (such as core campus and the medical center) was clearly stated as “an area for improvement.” This concept—when coupled with the stated goals “to preserve and restore historic and environmental features” and “to enhance the visual character” of the campus—has set the groundwork for the planning and campus design activities that have successfully followed since that time.

Initial examples include the *Main Quad Design Guidelines* (1991, revised 1994), which have guided the seismic repairs, restoration, and infrastructure upgrade of the more than thirty buildings, including the Stanford Main Quad (1991 – 2002), and the Palm Drive restoration project (1992). This latter project, not only repaired the quality of the street, pedestrian paths, and landscape, but also developed the granite-curbed, unobtrusively-drained entryway as intended in Olmsted’s original design. These projects have been well received publicly, earning many design awards, including the National Trust for Historic Preservation Honor Award (2000) and the State of California Governor’s Historic Preservation Award (1999).

Central Campus Design Guidelines (1991, revised 1999) and *Stanford University Medical Center Design Guidelines* (1992) have been developed in such a way that they recognize not only the uniqueness of each region, but also their site planning and landscape similarities. These guidelines re-establish the site planning principles of orthogonality, vista, circulation and connectivity in such a fashion as to mandate the restoration of the grandeur and intelligibilities of

SECOND CENTURY PLANNING PRINCIPLES

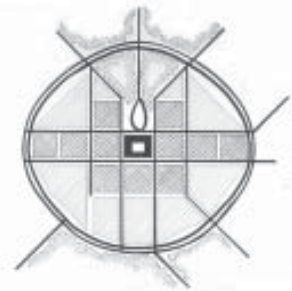
Fundamental Elements, 1991
(University Architect/Planning Office)

Memorial Church and Palm Drive

the original plan without necessitating wholesale demolition of anomalous buildings. They call for careful accommodation of landscape patterns and materials, and set various building design controls, especially in massing, roof form and material options. In short, they require new facilities (both architecture and landscape) to be *of Stanford*, not merely at Stanford—as had happened often in the past.

The hierarchy of plan, landscape, and architecture is therefore resolved on a project-by-project basis. To fill in gaps among individual project sites, landscape connectivity projects ranging from pedestrian walks and bikeways to site furnishings, lighting, and signage were developed through the Stanford Infrastructure Program-Campus Systems (SIP-C). Funded by a surcharge on capital projects since 1986, SIP has significantly enhanced the harmony and functionality of both the campus and the medical center, despite their growth of more than two million square feet within the past decade. A prime example of such a project is Serra Mall, the major east-west circulation element across the campus. Once a disfunctional collection of overly wide remnant street sections, it has now become a narrowed bicycle and shuttle way with curb-separated sidewalks. Along its route, more than two acres of formerly paved area has been returned to landscaped open space. It has been used as a model for the renovation of both Lasuen (1999) and Lomita (2001) Malls, which run on either side of the Main Quad in a north-south direction. Together with Palm Drive, these malls are the four major pedestrian and bicycle arteries of the campus core.

Though more than two-thirds of Stanford's billion-dollar capital development program over the past decade has been devoted to renewal or restoration of existing space, substantial new buildings have been added to the campus. As mentioned previously, each has been subject to a rigorous implementation of specific design guidelines with regard to siting, massing, design character, and color/material palette. In short, each has been a carefully inserted infill project, where each contributes to the unity of the campus. The best example to cite is also the largest: the Science and Engineering Quad (SEQ) (1995-2000). I exemplifies the Olmsted-Stanford plan (1888) and the Plan for the Second Century (1991) in its reliance on the axial ordering set by Serra Mall, the North/South Mall and the Main Quad's east-west axis, and its use of perimeter arcades to define a central space.



Serra Mall Fountain, 2000
(Sebastian & Associates)



Science and Engineering Quad, 2000
(Pei Cobb Freed and Partners/Olin Partnership)

The design by Pei Cobb Freed & Partners and the Olin Partnership, was chosen through an invited design competition in 1995. Laurie Olin, FASLA adds that the SEQ, like the Main Quad of Stanford's original plan, creates an "*order that could extend off indefinitely*"—an order that noted architectural critic Aaron Betsky asserts "*tie(s) the campus to its physical and symbolic roots.*" In a similar fashion, the four SEQ buildings are contemporary variations on the Stanford theme: that is, *of this special place.* Betsky notes the following:

"The Advanced (Moore) Materials Laboratory and Sequoia (Statistics) Hall are closest to the campus core. Their design tries to adapt the bearing-wall and gable-roof construction you find there to a modern idiom ... the Packard Electrical Engineering Building and the Regional Teaching Facility then start to break open and abstract these forms into larger, geometric masses and expressive curves ... that gesture towards the new part of the campus." (Architectural Record, July 1996).

Other projects, ranging from Ricardo Legorreta's Schwab Residential Learning Center (1997) on the east side to Antoine Predock's Allen Center for Integrated Systems (1995) on the west side, follow the same integrating approach to complex and competing challenges: site/landscape/architecture and historic context/current program. Each is successful in its outcome because of its resolution of these issues and its response to a specific context and guidelines. The work completed in the current epoch is responding well to that challenge, as architectural author and critic Michael Cannell wrote in 1997:

"As they pass among flower beds and arches, sunlit tiles and shaded arcades, students will see that the smallest details help to express the whole. As a place restored, Stanford can be an example to those who would look beyond the ubiquitous influence of cars and other small scale conveniences. The Stanford of the 21st century might not be perfect, but it does suggest that all the glories of the 19th century landscape design can live again. And that is an exciting prospect."

Or as former President Gerhard Casper noted in 1998 in addressing the State of the University:

"I hope Stanford will have a campus second to none, not only in its functionality, but also its beauty."



Moore Applied Materials, 2000
(Pei Cobb Freed and Partners)



Schwab Residential Center, 1997
(Legorreta Arquitectos/The Steinberg Group)



Allen Center for Integrated Systems, 1995
(Antoine Predock Architect)

II. BACKGROUND: STANFORD CAMPUS PLAN

The original plan for the Stanford campus was brought into existence through the intense efforts of the Stanfords and Olmsted, along with Charles Coolidge of the architectural firm of Shepley, Rutan and Coolidge (the heirs to the practice of H.H. Richardson). Attracted to the *Beaux Art* style of planning, landscape, and architecture they had seen in Europe, the Stanfords insisted on a formal entry road (Palm Drive), ending in imposing architectural presence (the Main Quadrangle and the Memorial Church). Olmsted had argued for a more naturalistic siting of roads and buildings linked to the foothills. Despite disagreements, the Stanfords, Coolidge, and Olmsted managed to create, at the end of the nineteenth century, what has become an iconic image for Stanford. It remains a powerful and intelligible plan with mission-style buildings of local materials arranged around courtyards and linked by covered arcades set in a strong naturalistic landscape.

The orthogonal plan of the Quadrangle and its placement on the flat plain, rather than in the foothills, was intended to provide for expansion of the University through a series of quadrangles developed laterally from the original Main Quadrangle. In the decades following the 1906 earthquake, the prominent San Francisco architectural firm of Bakewell and Brown designed a series of buildings east of the main quadrangle—Bing Wing of Green Library, the Education (Cubberley) Building, the Thomas Stanford Art Gallery, and Hoover Tower. The intent was to join these buildings by covered arcades into a second quadrangle. World War II intervened, and the connecting arcade plan was subsequently abandoned.

In the post-war period, building plans attempted to recall the historical architecture while taking on more modern designs and materials: the Stern and Wilbur residence halls, for example, were built around smaller scale courtyards of similar proportion to the Main Quadrangle, although in a starkly modern style. Landscaping design also continued to reflect a balance in the contrast of the rugged natural plant palette of oak woodland with formal planting in developed courtyards and malls.



Olmsted Plan, 1888



Education Building, 1937-1938
(Bakewell and Brown)



Stern Hall, 1947-1948
(Spencer and Ambrose Associates)

Among the things the University is trying to accomplish, through the development of the campus plan, are the following:

- *To reinvigorate the original axes that gave (or were planned to give) a strong visual order and connectivity to the campus.*
- *To create clearly defined outdoor spaces that work in harmony with the campus plan's axial ordering system.*
- *To impose a sensitive landscape treatment to characterize special places and to reinforce the original landscape principles of the campus.*
- *To re-establish a level of consistency in the architecture vocabulary; i.e. scale, materials, colors, etc. of new buildings.*

Complimentary to these formal goals, the University has been pursuing several other, more functional, objectives (also on a campus-wide basis) which are:

- *To concentrate on the (student/faculty) pedestrian as the predominant user of the facilities—and therefore to attempt in every project to facilitate pedestrian movement and safety, and to create a comfortable atmosphere for pedestrians.*
- *To rationalize the utility systems that serve the campus buildings, and to provide controlled access for service and delivery vehicles.*
- *To concentrate necessary inner campus vehicular parking in accessible locations, and to relocate and/or diminish the number of invasive small parking areas by relocating major parking areas to the perimeters of the campus.*
- *To provide alternatives to the private automobile for movement within, as well as to and from, the campus.*
- *To promote an ever-increasing use of bicycles and an expanding system of shuttles to both the surrounding communities and peripheral parking facilities.*



Lasuen Mall, 2000
(SWA Group and University
Architect/Planning Office)



Marguerite Shuttle

III. PARAMETERS

Stanford University strives to be an ever accommodating, yet enduring environment; its planning, landscape, and architecture must reflect this. These guidelines are intended to preserve the character defined in the original campus plan, while directing future growth and change in a fashion sympathetic to the Founders' intent now, more than a century later. The objective is to allow and to encourage the central campus to continue to evolve in such a way that each building (and its programmatic needs) develops a distinct value of its own, while respecting and contributing to the overall campus environs; i.e., the sense of place that is Stanford University.

No written guidelines can fully detail all aspects of the central campus design criteria; nor should they imply direct imitations of any existing facility in the region. They do “guide” each new project to respond to its program, its immediate context, and its Stanford heritage. The guidelines are intended to stimulate creativity with the ingredients of a given site and facility program. The resulting designs will reflect Stanford's commitment to its traditions of excellence, its respect for its heritage, and its relationship to the surrounding region. *It is a matter of interpretation, not imitation.*

The Stanford University central campus is a balance of physical planning, historical evolution, and technological progress. The environment should inspire confidence in faculty, students, staff and visitors through the humanity of scale; confirm commitment to a sustainable future; exhibit detail and finish of its spaces; and express overall physical harmony.

Although not intended to be substantially prescriptive for a specific design outcome, Stanford's design guidelines are intended to define parameters within which a compatible design can be achieved. Therefore, design guidelines provide direction for both the project design team and the user representatives in understanding the physical characteristics of a building and/or landscape design that is acceptable within the Stanford University context.



Main Quad Arcades, 1892



Science and Engineering Quad Arcades, 1999

These guidelines join programmatic, site, and other regulatory constraints to form the boundaries within which the array of responsive design alternatives can be created.

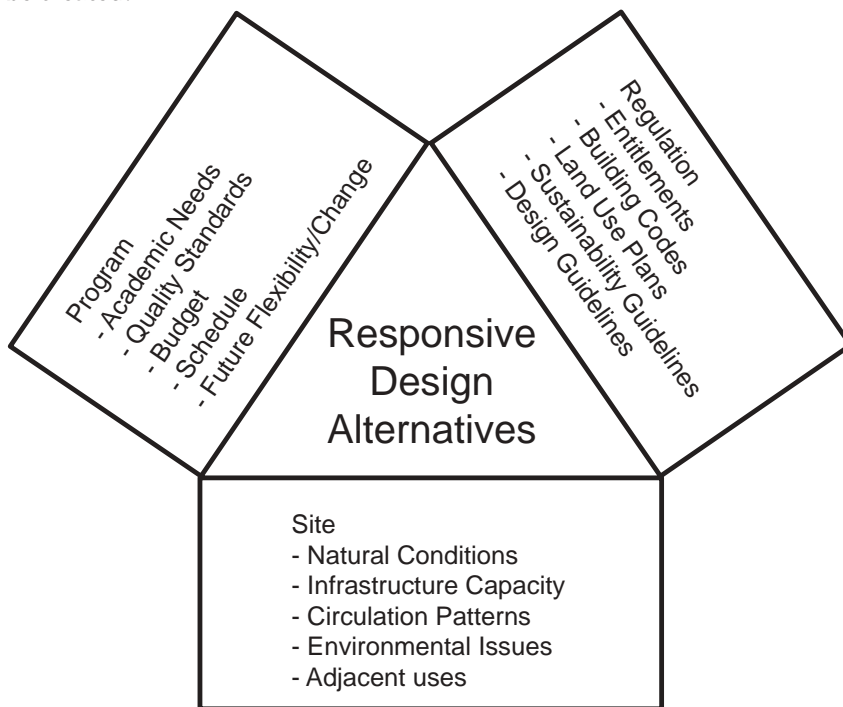

Related Documents

All development within the core Stanford University campus must comply with the codes and regulations of the State of California, the County of Santa Clara, and the Trustees of Leland Stanford Jr. University. Further information on the programmatic goals and the design character of Stanford University can be found in the *Stanford University Community Plan* (2000), the *Stanford University Campus Plan Report* (2002), the *Stanford University Medical Center Land Use Area Analysis* (2000), the *Stanford University Medical Center Design Guidelines* (1992), and the following special component plans: Lighting, Site Furnishings, Signage, Circulation, and Landscape Design Guidelines developed by the University Architect/Planning Office.

IV. PLANNING GUIDELINES:

SITE AND LANDSCAPE CHARACTER

Important to the success of the early Stanford campus were its open spaces, including the grand entry sequence created by Palm Drive, the Arboretum and the Oval, as well as the more intimate grandeur of the Inner Quad. These were so carefully integrated with the buildings that they are considered as inseparable units. In fact, the original campus was conceived in terms of a system of axes and courtyards around which both the open spaces and the buildings defining them were organized. Stanford is reinvigorating these broad, organizing principles of the campus design, and its open spaces, as defining elements of the Stanford experience.

As with the design of individual buildings, the intent is to emphasize continuity with the best aspects of earlier campus planning. In one sense, this is to be taken quite literally—as the extension of axes and completion of spaces. In another, it means that these open spaces should serve as “connective elements,” performing the same function as physical arcades that define and link exterior spaces. Each connective element must not only be excellent individually, but also superior in its contributory role in *campus building*.

Several of the recently completed and important connective spaces of the central campus are detailed as follows:

Serra Mall

Along the north edge of the Main Quad and the two flanking “quads” is a zone approximately 200 feet wide that was portrayed in the early renderings of the campus as the principal east-west link of the plan, extending laterally from the front side of the Main Quad about half a mile in each direction. While this zone was never completed as foreseen by Olmsted, it has remained largely free of intrusion by buildings—except at its western extension where the Cogeneration Plant is located. Recent projects have converted Serra *Street* into Serra *Mall*—a pedestrian/bicycle/transit mall (with two recovered areas of landscaped open space) which acts as a linear connector across the entire campus.



Central Campus Plan, 2002



Serra Mall at Main Quad, 1999
(Sebastian & Associates)

The expectations for Serra Mall include:

- Buildings to the east and west of the Main Quad have, with the noted exception of Hoover Tower, always been in line with the north face of the Main Quad. This line will continue to operate as a visual datum across the core campus.
- To the east of the Main Quad, Tanner Fountain has become a landscape design focal point on Serra Mall. A companion piece to the west (where Serra crosses the North-South Mall) is now complete (2000) with another fountain and related plaza adjacent to the Packard, Gates, and Gilbert buildings—thus providing a visual balance to the mall. These fountains provide a sense of scale, which improves wayfinding along this long axis.
- The landscape character of this area remains relatively informal. In particular, Serra Grove (the wooded area immediately west of the Main Quad) has been retained and enhanced—and now resembles Dohrmann Grove, which is situated to the east of the Main Quad. It is intended that new groves will be introduced at appropriate locations along Serra Mall; e.g., at the Schwab Center, in order to reinforce an informal character along this more urbanized transit mall.
- The mall will be expanded to the east to connect with Campus Drive (2002), though auto traffic will be allowed to continue in this section; and to the west past the Central Energy Facilities to Panama to Governor’s Lane Mall, and eventually to the Stockfarm Parking Structure.



Tanner Fountain



Serra Mall at SEQ

Lomita Mall

Along the western edge of the Main Quad is an area recently restored (2001) to large turf panels occupied by magnificent oak and cedar trees. The removal of Bloch Hall, the reconstruction of the West Gate, and the construction of the SEQ allowed for the redefinition of this area and the restoration of a major east-west pedestrian axis.



West Gate

Among issues that were addressed are the need for:

- A clearer definition of the western edge of the Main Quad to the SEQ—that includes landscape improvements to incorporate the existing Varian, McCullough, and Moore buildings, and responds to the façade of the Main Quad itself.
- A transition zone between the Main Quad and the SEQ that is a key part of joining two strong landscape and architectural designs, as well as facilitating human connections among the schools. This has mandated a complete rehabilitation of the western gate, “portal” and courtyard to the Main Quad.
- A functional, safe circulation corridor that is subject to intense pedestrian and bicycle traffic.



Lomita Mall, 2002
(Sebastian & Associates)

Service Roads

In spite of their clear subordination to the grid of pedestrian malls, which organize the campus, service roads are a vital and needed component. They will inevitably share a certain amount of pedestrian and bicycle traffic, so they should be designed and maintained to be as pleasant and safe as they are, practical.

- Service roads should be designed to minimize paved areas and to screen service yards where possible.
- Specialized parking must be provided for various purposes; e.g. disabled-occupant and service delivery vehicles.



South Service Road, 2000
(BKF/Olin Partnership)

Ancillary Spaces

In studying the development of the early campus, it becomes clear that there are virtually no “left over” spaces. Even the smallest areas between buildings are developed as courtyards, gardens, passageways, or seating areas that enhance both the functionality and the overall ambience of the campus. This principle is being maintained throughout the central campus, with such areas as the Oregon “cherry blossom” Courtyard at Pigott Hall and the Kresge Plaza at Green Earth Sciences.



Oregon Courtyard, 2000
(University Architect/Planning Office)

FACILITY SITING CRITERIA

New facilities need to be sited according to tenets, which recognize both the heritage of the past and the opportunities of the future. Generally, these standards are as follows:

- Conforms with 2000 Stanford Community Plan and district/region plans
- Reinforces functional relationships with other components of the same department or program, and is compatible with neighboring uses
- Meets access requirements—pedestrian, bicycle, vehicular, service
- Maximizes infill opportunities to utilize existing infrastructure
- Maximizes the options for incorporating sustainability principles in terms of solar orientation, relationship to existing common infrastructure, etc.
- Avoids unnecessary environmental impacts, including heritage tree or historic building removal
- Minimizes site development costs—clearance, utilities, access, parking, topography, and special conditions
- Minimizes opportunity costs; i.e., value of this use and size versus other alternatives
- Provides a size that is adequate, but not excessive, for initial program, future expansion, and ancillary uses
- Allows site visibility and image as appropriate for the intended use
- Allows for an aesthetic character which is appropriate for the neighborhood
- Minimizes time for implementation of project

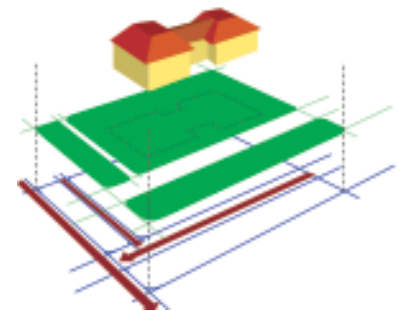

Infrastructure Issues



EV Infill Units, 2001
(Solomon Architecture/James Guthrie & Associates)

CIRCULATION ELEMENTS

There are many kinds of circulation on Stanford campus. For many years after World War II, campus planning was involved only in facilitating the movement and parking of private vehicles into the inner campus. Since 1972, however, planning and policy have involved the restriction of same, and the encouragement of a range of alternatives to the private automobile and the unrestricted service vehicle. Thirty years ago, the Stanford administration and Trustees initiated the programs and projects to close off the core campus to private vehicles, and to move their parking to the perimeters of the campus.

Pedestrian Circulation

Pedestrians are the most important users of the campus; their movement and safety are fundamental to the design of any element on the campus. Accommodating functional and safe pedestrian spaces are central to the success of any circulation plan. In fact, pedestrian access is critical to the future of the campus as it has been traditionally—from Jefferson’s University of Virginia in 1814 to the newest campus of the University of California in Merced, scheduled to open in 2004.

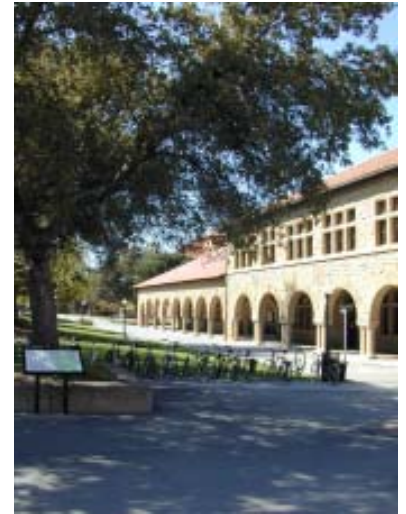

Escondido Mall

Bicycles and Bike Parking

In general, bicycles can go anywhere people go, and at Stanford they generally still do. Bicycles are the principal mode of travel for the majority of students on campus, and a large portion of the rest of the campus community. While the 20,000 bicycles on campus are not currently precluded from any area, they can present a significant safety hazard to pedestrians, as well as to themselves. Whenever feasible, Stanford is developing bike circulation routes that are contiguous, but separate from pedestrians; and is attempting to funnel major bicycle circulation into certain clearly defined corridors, such as Serra Mall, Lasuen Mall, and Lomita Mall.



SEQ Bike Compound

In addition, thousands of secure bike racks (most in landscaped compounds) have been added to the campus in the last decade. Each new and renovated building is analyzed for its bike parking need and accommodated accordingly.

Automobile and Alternative Vehicle Parking

The scale at which pedestrians and vehicles function best is not the same. Stanford has chosen to address this difference in part by developing parking structures to consolidate vehicles in designated outer campus areas, while providing clear pedestrian travel routes from them to popular destinations in the central campus area. A “Pedestrian Safety Zone” in the central campus has been established where vehicle travel is restricted and pedestrians can travel with minimal impact from cars and trucks. Surface parking lots—such as at Tresidder Union— and small parking areas adjacent to buildings, provide additional parking for visitors, special events, and delivery/service vehicles. As electric carts and other alternative vehicles become more commonly used, specific parking areas will be designated for their use.



Parking Structure V, 2002
(ELS Architects/Peter Walker and Partners)

Transit

The campus operates a network of shuttle buses (Marguerite) along certain routes. This system has been expanding, especially as private automobiles are moved further away from the center of campus; and as freshman cars were prohibited.

The Marguerite shuttle system operates over many of the same paved areas used by bicycles and emergency vehicles; and therefore, must be planned accordingly, including secure and safe bus stops.



Marguerite shuttle on Serra Mall

Service and Delivery

The Stanford campus is host to a broad range of service and delivery vehicles. These come in all sizes and at all times of day. To the extent possible, it is best to have special loading and entry zones for these vehicles, and special routes separate from major bicycle and pedestrian routes. These areas must be screened properly and allow for code-compliant trash and recycling containment enclosures.



Service vehicle parking @ GSB

SITE & LANDSCAPE CHARACTER

Open space treatment has always been critical in maintaining Stanford's unique campus setting. Many outdoor areas assume dual roles: as individual spaces physically and socially connected to adjacent architecture, and as shared areas that contribute to overall campus unity, circulation, and character. The guidelines presented here have been developed to assure that new connections and spaces blend with old; and, therefore, preserve and enhance the original campus plan and character.

Urban/Rural Mosaic

Two distinct landscape types are seen in the central campus. This mix of landscape spaces, the "urban/rural mosaic", is a character distinct to Stanford and key in preserving its unique sense of place. A campus wide balance between urban and rural landscape types is desired to preserve diversity and interest, and to allow for a range of activities and uses. New site development is based on this balance, and the site program, natural, systems, and spaces surrounding the site.

The rural landscape is defined loosely as hillsides, creeks, natural drainage systems, and unirrigated grasslands, with predominantly native trees, randomly spaced. It may include clusters of native under-story shrubs, with mulch, native grasses, or leaf litter as ground cover. The urban landscape is a mix of plazas, pathways, courtyards, and playfields with more formal and ornamental plantings that are generally more water and maintenance intensive than rural areas. Urban landscapes at Stanford are simple, clean, and uncluttered.

Rural landscapes begin in the foothills and continue through campus to undeveloped areas on the west campus, and areas intentionally kept from development around the Oval, Lagunita, and the Arboretum. A rural mosaic piece can be created as it was along Serra Mall in the Science and Engineering Quad area when oaks, redwoods, and cedars were planted and transplanted to form the SEQ Grove. Ordered, urban landscapes dominate in the academic areas of campus, where open space is fragmented and often serves as a conduit for pedestrian and bike circulation.

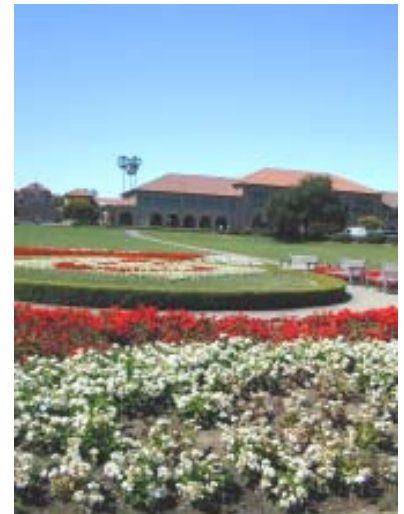

Urban landscape at the Oval



Rural landscape of Oak trees

Landscape Development And Treatments

Landscape development at Stanford is based upon five broad planning concepts:

- grand scale
- response to climate
- juxtaposition
- “a place apart”
- permanence

Below are techniques illustrating these concepts, which are used (as appropriate) in designing new landscapes.

GRAND SCALE

Stanford’s 8,200 acres of planned and managed lands offers students, faculty, staff, and the general community both the convenience of urban amenities and the ambiance of meadow and hilltop vistas. This grand sense of scale and diversity is used to shape spaces that fit comfortably within the larger campus context. The recent Serra Mall restoration was successful in re-establishing a grand pedestrian avenue and vista in place of what had become a cluttered and constrained mixed circulation artery. Repetition of materials, details, and plantings along the route provides unity and contributes to scale.



Foothills above the core campus

RESPONSE TO CLIMATE

In 1886, Olmsted argued for designing architecture and open spaces responsive to the local climate. This practice is encouraged today to preserve regional ecology and habitat, conserve water, and maintain uniqueness. Plant selections are drought tolerant and include California natives where practical. All plantings are hardy and low maintenance, providing function more than color or ornament. Areas of usable lawn are conservatively provided in shared spaces for multiple users. The trend toward more sustainable architecture and landscapes has been embraced at Stanford—as exemplified in the Center for Clinical Sciences Research building with its passive energy systems and shaded



CCSR, 2000
(Foster and Partners/Fong and Chan Architects)

breezeway and cafe. Water conservation is accomplished in part through the use of drought tolerant plants and GPS – computer regulated water output for both irrigation and water features.

JUXTAPOSITION

Tension in the landscape, created with opposites, produces interesting and memorable spaces. At Stanford this is seen where the lush lawn of the Oval is accented with patterned color plantings, and sits adjacent to dry, wildflower-covered picnic areas shaded by gnarled oaks. Granular compacted paving and gravel is often used as a companion to asphalt and concrete in both historic and new areas. The urban/rural mosaic concept, discussed above, uses juxtaposition to bring historic “farm” landscapes (like the Arboretum) into an increasingly urban campus. Symbolically, these juxtaposed landscapes reflect an acceptance of diversity that mirrors University-wide values and philosophies.



Oval “ears” w/ rural landscape

A PLACE APART

The Stanfords reasoned that scholars need “a place apart”—a retreat buffered from the traditions of everyday life where creativity can flourish. Today, academic program development and housing needs are eroding buffers that separate Stanford from “the city”. To keep the campus as a distinct place, the Arboretum, Palm Drive, and a portion of the West Campus will remain as symbolic rural buffers between the everyday, public world and Stanford’s focused, academic world.



“A Place Apart”

PERMANENCE

The Stanfords chose simple, practical design solutions and durable, stable materials. Olmsted’s plant palette contained California natives and Mediterranean climate plants that survived unassisted in Stanford’s microclimate. Much of the historic Main Quad plantings and buildings still exist today. Future choices for materials and treatments must remain simple, address functional needs, avoid trends, and promote Stanford’s sense of place. Conservative use of granite curbing on historic axis roads, colored asphalt pavers for pedestrian malls, asphalt pedestrian paths, and protection of established trees and unusual plants contributes to Stanford’s enduring landscape.



Inner Quad

Loop Road

Campus Drive is a loop road that circles the academic and undergraduate student residential areas of campus and extends south to Junipero Serra Boulevard, and thus around Lagunita. It is currently being rebuilt to be unique and recognizable, improving its usefulness as an orienting and wayfinding route. Guidelines for pathway and intersection layouts, median width, lighting, and plant materials are finalized. All site development adjacent to Campus Drive will follow these guidelines, including maintaining a fifty foot (50') setback and a four story (40'-45') height limit for all buildings.



Campus Drive setback

Malls

Campus axes linking major use areas should be noted and enhanced. Planning and phased construction is ongoing to strengthen the east-west axis through the Clark Center, the north-south axis through the Science and Engineering quad, and historic Governor's Avenue from Lagunita through west campus to the Medical Center. A section of Lomita Mall along the Main Quad was renovated in winter 2001; another phase of construction for Serra Mall will begin summer 2002; and the next phase of Lasuen Mall, in 2003. In addition, a series of landscaped malls have been constructed in the athletics area of the campus, in order to order and unify this area of the campus.



Mall in athletics area

Standards

Repetition of forms and colors in the landscape creates unity and a sense of place. One option for achieving this is through the use of standardized site furnishings. The University Architect/Planning Office has preselected the types of outdoor benches, ash/trash/recycle containers, picnic tables, bike racks, lights, and signs to be used on campus. Specifications for models, colors, and suppliers can be found on the Facilities Design and Construction Guidelines website: <http://www-facilities.stanford.edu/fdg/>, or by contacting the University Architect/Planning Office.



Standard site furnishings

ARCHITECTURAL CHARACTER

There is a fine line between mimicry and honoring a strong architectural tradition. Stanford's strong architectural character is anchored by the Moorish/Spanish character of the Main Quadrangle, and its materials and detailing. The central campus, however, has evolved with new technology, codes, and programs that have required adaptation and change. Achieving continuity of character (while also acknowledging change) has been difficult, but can be guided in the future by a few strong design principles. The challenge is to be inspired by tradition without stifling innovation. These tenets are stated simply below.



Main Quad Illustrative, 1888

Building Form and Massing

Building masses are generally to be three to four stories in eave height (above grade) (40' – 60'), and respond to the relationships of (negative) voids and (positive) masses evident in the Main Quadrangle. Interaction of indoor and outdoor spaces, in the form of courtyards, arcades, and other in-between spaces, is a significant element of the character of the Main Quad, and should be a part of the character of any core campus building. In order to enhance the human scale and articulation of buildings, the thickness of exterior walls should be emphasized to create shadows on the façade. A building's character should reflect its site and its surrounding context, as well as its function—to an appropriate degree.



Main Quad façade, 1892
(Charles Coolidge)

Building shape and scale should be of a human proportion. There are numerous ways to reduce the appearance of excessive bulk in large buildings:

- Articulate the different parts of a building's façade to accommodate human scale and its daily sensations.
- Alter the exterior walls in depth and dimension.
- Vary the height of the building to create distinct massing elements.
- Use landscaping and architectural detailing at ground level to lessen the impact of building.
- Incorporate courtyards into a building's design as links to building wings and/or as entry courts.
- Utilize entry courts to help reduce building mass, to orient users, and to foster interaction of users.



Sequoia Hall façade, 1998
(Pei Cobb Freed and Partners)

Façades

The building façades should exhibit a respect for the historic context and qualities of the Stanford campus, without simplistic imitation. Large scale use of curtain walls is precluded; however, a more framed modulation, with well-recessed windows is more in keeping with the context of the Main Quad and the local climate. Passive solar design must be taken into account in this regard, as it was in the original planning of Stanford.

Selected articulated portions of buildings may have a curtain wall or column/beam structural expression, but this expression should not dominate the building.

Fenestration

Windows and doors in the exterior walls should be recessed to represent expression reminiscent of the historic Main Quad.

The placement and proportion of windows should respect solar orientation, views, and daylighting needs.

Operable windows with clear (low-E) glass should be used whenever feasible.

Larger openings can be used to express principal entries, gateways, or atrium features. These should be inviting, yet energy efficient.

Building Entries

Primary entries should face onto major malls/streets, or onto the major adjacent open spaces. Building entries should be easily identifiable and expressly detailed to give a positive impression to those who enter. In general, buildings should open directly onto grade or onto terraces that are visually linked to, and easily accessible from, the surrounding grade.



Thornton Center, 1995
(Tanner Leddy Maytum Stacy)



Gates Computer Sciences, 1999
(Robert A.M. Stern Architects)



Alumni Center entry, 2001
(Hoover Associates)

Roofs

Special attention should be paid to the arrangement and design of the roof and its various elements. Roofs should be organized and designed as carefully as the other primary exposures of the building. Equipment must be placed within enclosures well integrated with the roofscape.

The major roof form should be sloped at an angle of 27–30 degrees and should have an overhang (eave) proportional to its size and height (2'-6"–4'-0" generally).

Secondary portions of roofs may have a flat-roofed area to accommodate mechanical equipment or scientific instruments, in visually unobtrusive areas.

Roof slopes normally will continue around all corners (hipped rather than shed or gable roofs).

Stacks

Exhaust and plumbing stacks should be grouped and incorporated into the architectural composition of the building they serve. When large in circumference, stacks should be articulated to reduce their scale.

As the stacks will be visible from a distance, it is important that they be designed with a certain degree of uniformity, so that the overall image from a distance is composed.

Placement and configuration of buildings and exhaust stacks should recognize that while prevailing winds are from the northwest, open air flow paths should be created and stagnant air pockets eliminated. (Note: All stacks should extend above each building's boundary layer and will be subject to wind tunnel analysis.)



Kimball Hall roof overhang, 1991 (BAR)

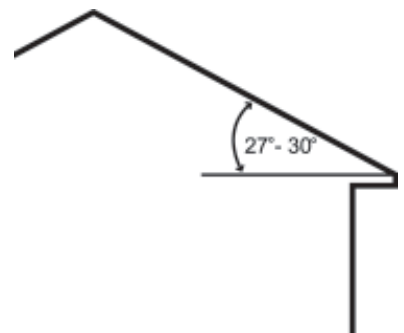

Roof Slope



Moore Building roof stack, 2000 (Pei Cobb Freed and Partners)

Arcades

Stanford University has incorporated arcades in its design since its beginnings, therefore arcades should be similar in size and proportion to those elsewhere on campus.

Arcades can be either freestanding or incorporated into the building façade and architecture.

Arcades should be designed to provide actual shelter from sun and rain.

Arcades should express the rhythm, proportion, and scale sympathetic to the Main Quad arcades and should be approximately 15 feet wide.

Colonnades, pergolas, and arbors can also be used to provide shaded connections.



Old Union Arcades



Packard arcades

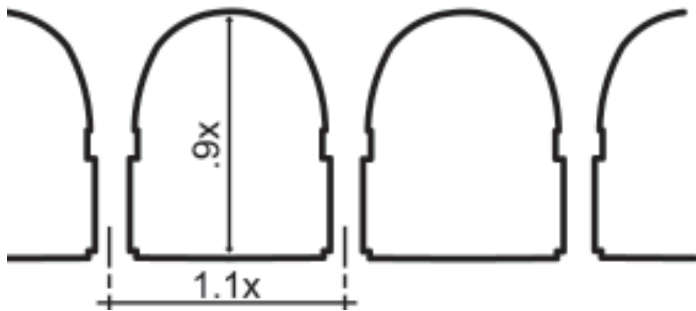

Arcade Height and Length Ratio



Pergola at Gov. Corner housing

Sustainability Criteria

Issues regarding sustainability are addressed in detail in *Stanford University Guidelines for Sustainable Buildings* (2002) and should be integrated into the design of Stanford buildings in consort with these guidelines are followed.

Solar Orientation

Buildings should be sited and designed to take maximum advantage of sunlight and natural ventilation, in order to enhance user comfort and energy conservation. Whenever possible, the following criteria should be addressed in order to take advantage of a building's orientation on its site:

- A shade/shadow analysis must be submitted for review during the design review process; the impact of this analysis should be reflected in the design landscaping and surrounding activity areas, as well as the affect on adjacent facilities.
- Shading devices such as building sunscreens, louvers, or façade articulation must be regarded in the overall building design.
- Use of landscape screening such as deciduous trees or trellises to allow control of the sun at various times of the year should be considered.
- Outdoor activity areas should be located with southern or southwestern exposure to take maximum advantage of the sun.

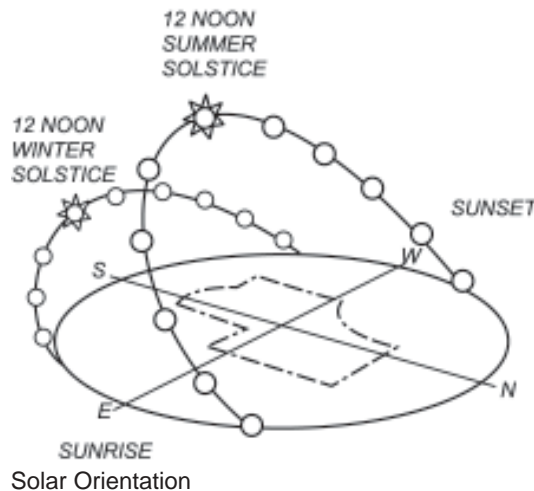

Lyman Hall sunscreens, 1997
(Tanner Leddy Maytum Stacy)

IV. MATERIALS AND COLOR

Materials

The materials employed should be appropriate for the building design concept and the character of the Stanford core campus. Materials must be appropriate to building form, mass, color, scale and context. Materials should have qualities of permanence and durability. Reflective materials are *not* permitted. Building materials designated for use in the core campus are:

Walls: Stone, precast concrete, architectural finish cast-in-place concrete, and heavily-textured stucco

Major roof areas: Clay tile - color: Stanford Blend or matching equivalent; type: "C", "S" or "flat" depending upon circumstance

Secondary roof areas: Weathering copper - standing seam or shingles

Gutters, downspouts, and rooftop appurtenances: Weathering copper

Glazing: Clear (non-reflective) or solex glass (low-E)

Windows and doors: Painted steel, bronze, anodized aluminum or solid wood

Colors

The color palette should be within the range of warm earth tones established in the Main Quad. Walls should be medium to light in color such as tan, ochre or buff, and roofs should be mixed orange-red terracotta color. Glazing colors should be limited to clear, light grey, and light green in color. Colors for mullions, railings, and storefront sections should be compatible with glazing color, and be chosen to dramatize the depth of the surrounding reveals; e.g., black, dark grey or dark green. Rooftop equipment and roof screens are to be painted a dark gray, in order to be visually unobtrusive.



Gates Computer Sciences stone patterns



Law School concrete texture



Schwab Residential Center gutter/downspout

SPECIFIC MATERIALS AND COLORS

Colors

Over the past decades, several material and color standards have been developed to the point where they have been designated “Stanford” colors (for paints).

“Stanford Black”: Kelly-Moore “Carbon Black Matte” #1245-407

“Stanford Green”: Fuller-O’Brien “Leafy Bower” #E-127

“Stanford Red”: Cardinal Paints 6406-60934-X-UV

“Stanford Grey”: Cardinal Paints 6405-60933-UV



Directional sign with red/grey/black

Stone Veneers and Granite - materials and colors

The current acceptable suppliers and colors of stone that are compatible with the sandstone and granite of the original Stanford University buildings are:

Carrara Marble Co. of America, Inc., “Amarillo Gold”

Rocamat (France), “Saint Maximin”

Mankato-Kasota Stone, “Golden Buff” or “Creme Veine”

Cold Springs Granite Co, “Sierra White”; and “Cornelian”

Precast Concrete

Tecon Pacific, #1086 PR (color blend for Gilbert Biology)

Tecon Pacific, (color blend for SEQ Sequia Hall)



Gilbert Biology, 1990
(Arthur Eriksen Associates/
McLellan and Copenhagen)

Roof Tiles

Gladding/McBean Two-piece (“C”), or one piece (“S” or “flat”) clay roofing tile. Color “Stanford SEQ Blend” or blended to match adjacent buildings

Bird caps are *not* be used on any one-story roof elements; and may only be used above this height when they are recessed a minimum of 3" from the edge of the leading roof tile, and have been painted, kiln-fired, or otherwise treated to be charcoal (flat) black in color.



Bird caps on Ford Center (ELS)

Installation Specifications

Selected categories of specifications are provided in *Stanford University Facilities Design and Construction Standards*, and should be used as samples for consistency of installation.

Mock Ups

For all significant new structures, a wall and roof mockup using full-size materials (windows, roof tile, eaves and gutters, etc.) is mandated prior to final selection of materials and colors. Final selections must be approved by the University Architect or a designer from this office.



EV 5 & 6 mockup, 2002 (Solomon Architecture/James Guthrie & Associates)